

TECHNICAL MANUAL

**ORGANIZATIONAL, DIRECT SUPPORT AND
GENERAL SUPPORT MAINTENANCE MANUAL
(INCLUDING REPAIR PARTS LIST
AND SPECIAL TOOLS LIST)**

**FOR
CRANE, TRUCK MOUNTED
HYDRAULIC 25 TON (CCE)
GROVE MODEL TM S-300-5
(NAN 3810-01-054-9779)**

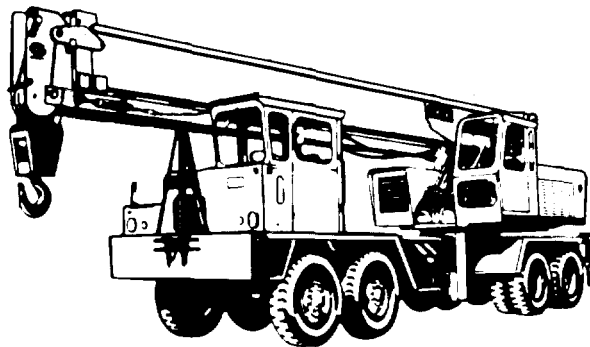

**VOLUME 2
(CARRIER)**

HEADQUARTERS, DEPARTMENT OF THE ARMY

8 MAY 84

WARNING

EXHAUST SYSTEM COMPONENTS CAN CAUSE SEVERE BURNS

During normal operation the vehicle exhaust pipe and muffler can become very hot. Be careful not to touch these components with your bare hands. Do not allow your body to come in contact with the pipe or muffler. Exhaust system components may be hot enough to cause serious burns.

WARNING

AVOID ACCIDENTAL ENGINE STARTS

Accidental Engine Start-up may cause severe injuries to service personnel engaged in maintenance operations of or near moving parts (pulleys, belts, fan blades, etc.). Prevent accidental engine starts by removing battery cables from battery posts. Make sure mechanism at governor stops engine in top position (no-fuel position) to prevent accidental engine firing.

WARNING

COMPRESSED AIR FOR CLEANING

Compressed air used for cleaning purposed shall not exceed 30 psi. Use only with effective chip guarding and personal protective equipment (goggles/shield, gloves, etc).

WARNING

ELECTROCUTION HAZARD

NEVER OPERATE this crane within any distance of a power source or power line without first notifying the power or utility company.

NEVER OPERATE crane any part thereof or load within 20 feet of any electrical power line or power source or such distance as is specified or required by local or other applicable safety codes or regulations.

NEVER OPERATE crane without consulting local or other applicable safety codes or regulations.

NEVER OPERATE, service or maintain this crane without proper instructions. Remember it is the employer's responsibility to implement the above and to provide all safety devices or means that may be necessary or required for any use operation, set-up or service.

CHANGE
NO.1

HEADQUARTERS
DEPARTMENT OF THE ARMY
WASHINGTON, DC 10 April 1987

**ORGANIZATIONAL, DIRECT SUPPORT
AND GENERAL SUPPORT MAINTENANCE MANUAL
(INCLUDING REPAIR PARTS LIST AND SPECIAL
TOOLS LIST)
FOR
CRANE, TRUCK MOUNTED, HYDRAULIC
25 TON (CCE)
GROVE MODEL TM S-300-5
NSN 3810-01-054-9779**

TM5-3810-30024&P2, 8 May 1984, is changed as follows:

1. Addendum B, Parts Catalog (Carrier) Pages B-1 through B-183 And C-1 through C-16 of this Manual have been replaced By TM5-3810-300-20P, ORGANIZATIONAL MAINTENANCE REPAIR PARTS AND SPECIAL TOOLS LISTS, and TM-3810-300-34P, DIRECT SUPPORT AND GENERAL SUPPORT MAINTENANCE REPAIR PARTS AND SPECIAL TOOLS LIST.

File this change sheet in front of the publication for reference purposes.

By Order of the Secretary of the Army:

JOHN A. WICKHAM, JR
*General, United States Army
Chief of Staff*

Official:

R.L. DILWORTH
*Brigadier General, United States Army
The Adjutant General*

Distribution:

To be distributed in accordance with DA Form 12-25A Organizational, Direct Support and General Support Maintenance requirements for Cranes, Truck Mounted, Hydraulic, 25-T, Model TM-S-300-5.

PIN: 055592-001

U.S. GOVERNMENT PRINTING OFFICE: 1993 - 342-027/80492

WARNING

CARBON MONOXIDE CAN KILL YOU!

DO NOT OPERATE vehicles in an enclosed area unless carbon monoxide (exhaust) is channeled out of work area (duct).

DO NOT OPERATE an engine, in or out of the vehicle, in an enclosed area unless there is a way for the carbon monoxide to escape (duct; draft or fan propelled fresh air supply).

DO NOT PERMIT an operating vehicle outside your work area to expel carbon monoxide into the area where you work.

WARNING

SERIOUS BODILY INJURY OR DEATH COULD OCCUR IF THE FOLLOWING BASIC SAFETY PROCEDURES ARE NOT OBSERVED

Only machines with published "ON RUBBER" capacities are permitted to travel with a load.

Before elevating boom, make certain that area above and beneath boom is clear of all obstructions and personnel.

Before lowering boom, make certain that area above and beneath boom is clear of all obstructions and personnel.

Before lowering or raising cable (load) assure that area beneath load is clear of all obstructions and personnel.

Outriggers must be extended and set anytime the boom is removed from the cradle, either lifting or positioning. Outriggers may be retracted from "ON RUBBER" operation with the boom centered over the rear as indicated by the "ON RUBBER" load chart. (Outriggers must be extended and set to place the boom in the "ON RUBBER" position.)

NOTE

PASSENGERS

Passengers are not authorized to ride in the crane cab to and from work sites. The crane operator may be permitted to ride in the cab for short distances where very light loads are being relocated, provided these loads are within the limits of operation without outriggers. These limits are specified on the load and boom angle charts located inside the crane cab.

**MAKE SAFETY FIRST --- NOT LAST
READ YOUR OPERATOR'S HANDBOOK !**

When Working On The Engine . . .

1. Consider the hazards of the job and wear protective gear such as safety glasses, safety shoes, hard hat, etc. to provide adequate protection.
2. When lifting an engine, make sure the lifting device is fastened securely. Be sure the item to be lifted does not exceed the capacity of the lifting device.
3. Always use caution when using power tools.
4. When using compressed air to clean a component, such as flushing a radiator or cleaning an air cleaner element, use a safe amount of air. Recommendations regarding the use of air are indicated throughout the manual. Too much air can rupture or in some other way damage a component and create a hazardous situation that can lead to personal injury.
5. Avoid the use of carbon tetrachloride as a cleaning agent because of the harmful vapors that it releases. Use perchlorethylene or trichlorethylene. However, while less toxic than other chlorinated solvents, use

these cleaning agents with caution. Be sure the work area is adequately ventilated and use protective gloves, goggles or face shield, and apron. Exercise caution against burns when using oxalic acid to clean the cooling passages of the engine.

6. Avoid excessive injection of ether into the engine during start attempts. Follow the instructions on the container or by the manufacturer of the starting aid.
7. When working on an engine that is running, accidental contact with the hot exhaust manifold can cause severe burns. Remain alert to the location of the rotating fan, pulleys and belts. Avoid making contact across the two terminals of a battery which can result in severe arcing.
8. Use extreme caution in releasing the radiator cap when engine has been running or is overheated.
9. When servicing the battery, do not smoke or allow an open flame near batteries. Batteries generate hydrogen which is a highly explosive gas.

Key to WARNING and CAUTION Notes:

WARNING precedes operating procedures or practices which, if not correctly followed could result in personal injury or death.

CAUTION precedes operating procedure or practice which if not strictly followed could cause damage to or destruction of equipment.

Information in this manual does not replace federal, state, or local regulations. safety codes, or insurance requirements.

Technical Manual



No. 5-3810-300-24 & P2

HEADQUARTERS
DEPARTMENT OF THE ARMY
Washington, DC, 8 May 1984

**ORGANIZATIONAL, DIRECT SUPPORT
AND GENERAL SUPPORT MAINTENANCE MANUAL
(INCLUDING REPAIR PARTS LIST AND
SPECIAL TOOLS LIST)
FOR**

**CRANE, TRUCK MOUNTED, HYDRAULIC
25 TON (CCE)
GROVE MODEL TM S-300-5
(NSN 3810-01-054-9779)**

Procured under Contract No. DSA 700-77-C-8511

REPORTING OF ERRORS

You can help improve this manual. If you find any mistakes or if you know of a way to improve the procedures, please let us know. Mail your letter, DA Form 2028 (Recommended Changes to Publications and Blank Forms), or DA Form 2028-2 located in the back of this manual direct to: Commander, US Army Tank-Automotive Command, ATTN: DRSTA-MB, Warren, MI 48090. A reply will be furnished direct to you.

**VOLUME II
(CARRIER)**

SECTION IV	
Introduction, Description	4-1
SECTION V	
Lubrication	5-1
ADDENDUM A	
Noise Abatement Program	A-1
ADDENDUM B	
Parts Catalog (Carrier)	B-1
ADDENDUM C	
Manufacture to Vendor	
Cross Reference Index	C-1
ADDENDUM D	
Vendor Code Listing.....	D-1

This technical manual is an authentication of the manufacturers commercial literature and does not conform with the format and content specified in AR 310-3, Military Publications. This technical manual does, however, contain available information that is essential to the operation and maintenance of the equipment.

Illustration 1 TMS300-5 Component Location.

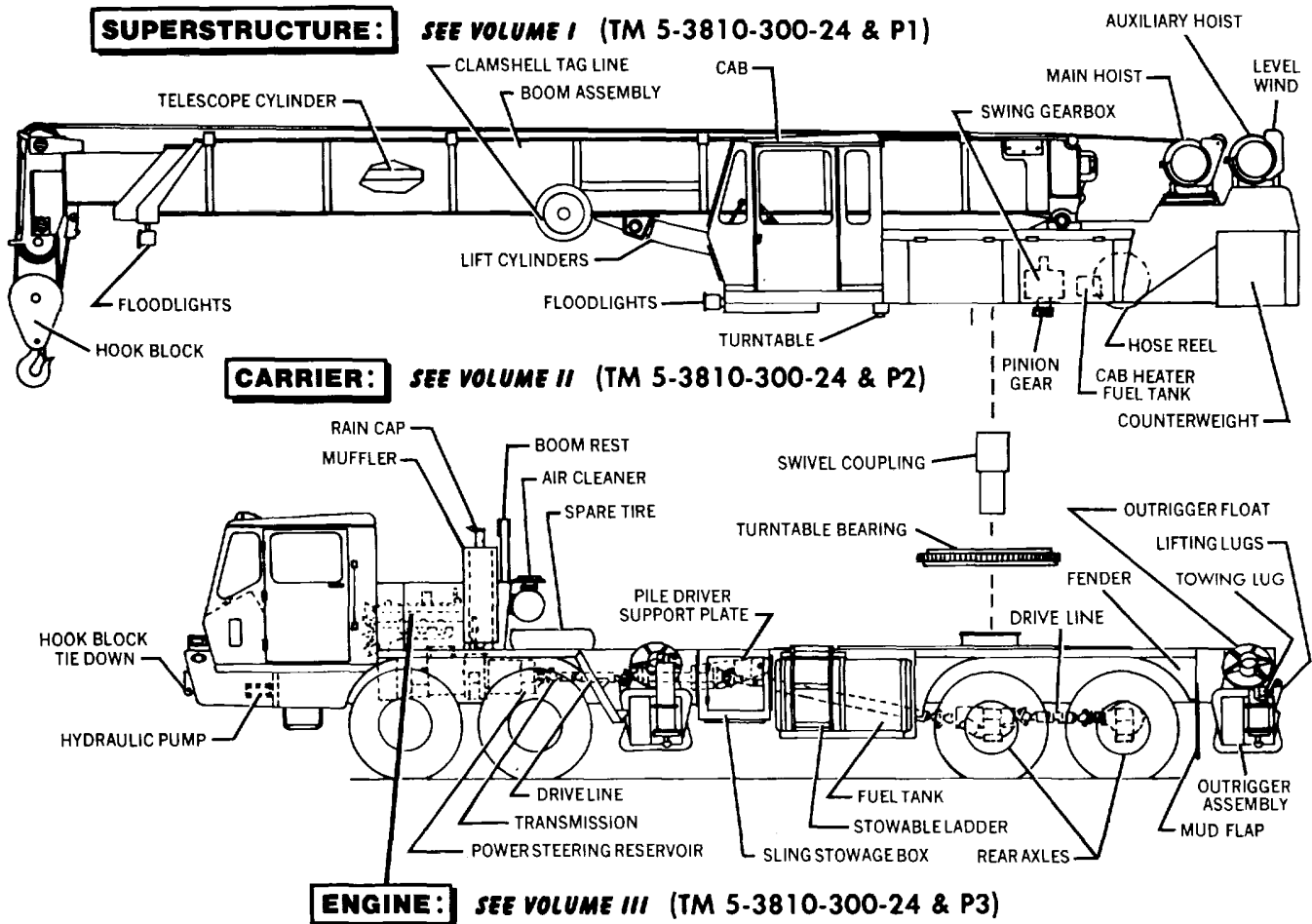

IMPORTANT MAINTENANCE INFORMATION

The quarterly Equipment Improvement Report and Maintenance Digest TB 43-0001-41 series contains valuable field information on the equipment covered in this manual. The information in TB 43-0001-41 series is compiled from some of the Equipment Improvement Reports (SF 368) that you prepared on the vehicle covered in this manual. Many of these articles result from comments, suggestions, and improvement recommendations that you submitted to the EIR program. The TB 430001-41 series contains information on equipment improvements, minor alternations, proposed Modification Work Orders (MWO's), actions taken on some of your DA Form 2028's, and advance information on proposed changes that may affect this manual.

TABLE OF CONTENTS

Title	Page
SECTION IV - CARRIER.....	4-1
INTRODUCTION	4-1
DESCRIPTION	4-5
Controls, Gages, and Indicators.....	4-5
DRIVE TRAIN.....	4-9
Engine.....	4-9
Fuel System Components	4-9
Lubricating System Components	4-17
Cooling System Components.....	4-19
Transmission	4-21
Clutch and Actuating System.....	4-29
Constant Speed Pump Drive	4-32
Front Axle and Steering.....	4-32
Power Steering System	4-35
Single Reduction Hypoid-Drive Nut.....	4-42
Single Reduction Drive Unit.....	4-42
Universal Joints and Drive Shafts	4-42
Air System.....	4-49
Brakes	4-56
Electric System.....	4-63
Heaters.....	4-63
Alcohol Evaporator System	4-71
Quick Start System.....	4-71
MAINTENANCE	4-73
ENGINE AIR SYSTEM	4-74
Air Filter	4-74
Ducts	4-76
COOLING SYSTEM	4-77
INSPECTION.....	4-79
TROUBLESHOOTING	4-83
FUEL SYSTEM	4-84
TROUBLESHOOTING.....	4-86
Constant Speed Pump Drive.....	4-87
DISASSEMBLY	4-87
REASSEMBLY	4-87
TRANSMISSION SYSTEM	4-93
Slave Unit and Gearshift Linkage	4-93
Range Control Valve	4-97
DISASSEMBLY	4-97
REASSEMBLY	4-97
TROUBLESHOOTING	4-97
Air Valve and Filter Assembly.....	4-98
TRANSMISSION TROUBLESHOOTING	4-99
LUBRICATION	4-105
RECOMMENDED LUBRICANTS.....	4-105
PREVENTIVE MAINTENANCE	4-107
Transmission	4-112
DISASSEMBLY	4-112
REASSEMBLY	4-165

Title	Page
CLUTCH	4-220
REMOVAL	4-220
INSTALLATION	4-220
ADJUSTMENT	4-226
COMMON SERVICE PROBLEMS	4-228
Single Reduction Hypoid Drive Unit	4-230
DISASSEMBLY	4-230
PREPARE FOR REASSEMBLY CLEAN, INSPECT, AND REPAIR	4-246
REASSEMBLY	4-248
TIRES	4-262
PINION	4-263
Pre-Load	4-263
ADJUSTMENT	4-263
GEAR	4-263
Pre-Load	4-263
ADJUSTMENT	4-263
Single-Reduction Drive Unit	4-264
DISASSEMBLY	4-264
REASSEMBLY	4-274
Front Axle	4-290
DISASSEMBLY	4-290
REPLACEMENT OF STEEL BACKED BRONZE STEERING KNUCKLE BUSHINGS	4-297
REASSEMBLY	4-298
LUBRICATION	4-302
Universal Joints and Drive Shafts	4-304
DISASSEMBLY	4-304
ASSEMBLY	4-304
INSTALLATION	4-304
LUBRICATION	4-306
Front Suspension (Reyco)	4-307
Rear Suspension (Hendrickson)	4-307
Toe-in and Synchronization of Steering Axles	4-307
Hard Steering	4-313
Steer Gear	4-323
ADJUSTMENT	4-323
LUBRICATION	4-324
Minimum Backlash of Typical Studs in Lam Groove	4-325
ADJUSTMENT	4-325
LUBRICATION	4-326
POWER STEERING SYSTEM	4-327
Hydraulic Pump	4-327
DISASSEMBLY	4-327
INSPECTION	4-327
REASSEMBLY	4-329
TROUBLESHOOTING	4-331
Steering Control Valve	4-332
DISASSEMBLY	4-332
REASSEMBLY	4-334
Cylinder	4-338
DISASSEMBLY	4-338
REASSEMBLY	4-338
Brakes	4-340

Title	Page
AIR SYSTEM	4-345
Compressor	4-345
DISASSEMBLY	4-345
REASSEMBLY	4-352
TROUBLESHOOTING	4-357
ELECTRICAL SYSTEM	4-359
Batteries	4-359
Battery set installation	4-360
Engine Instruments	4-361
REMOVAL	4-361
Electrical Switch	4-362
Windshield Wiper Assembly	4-363
HEATER ASSEMBLY	4-364
DISASSEMBLY	4-364
REASSEMBLY	4-364
Windshield Washer System	4-366
Maintenance	4-366
Alcohol Evaporator System	4-367
TROUBLESHOOTING ALCCHOL EVAPORATORS.....	4-368
SECTION V - LUBRICATION.....	5-1
LUBRICATION.....	5-1
GENERAL	5-1
CHASSIS.....	5-6
ENGINE OILS	5-6
DIESEL FUEL.....	5-9
LUBE SYMBOLS	5-10
LUBRICANT CAPACITIES	5-11
1978 EPA NOISE ABATEMENT PROGRAM (40 CFR PART 20S)	ADDENDUM A
PARTS CATALOG (CARRIER).....	ADDENDUM B
MANUFACTURE TO VENDOR CROSS REFERENCE INDEX	ADDENDUM C
VENDOR CODE LISTING.....	ADDENDUM D

LIST OF TABLES

No.	Title	Page
3-1	Hydraulic Pump Output	3-11
3-2	Pneumatic/Hydraulic Swivel Ports	3-11
3-3	Main Relief and Circuit Relief Valve Settings	3-27
3-4	Torque Valves, Nut-Bolt Combinations Plated or Lubricated with Washers	3-52
3-5	Torque Valves, Nut-Bolt Combinations not Lubricated or Plated	3-53
3-6	Cylinder Head Bolt Torque Valves.....	3-54
3-7	Boom, Lift and Pivot Shaft Set Screw and Jam Nut Torque Valves.....	3-54
3-8	Troubleshooting - Supply and Return System	3-174
3-9	Troubleshooting - Lift System.....	3-175
3-10	Troubleshooting - Telescoping System	3-178
3-11	Troubleshooting - Swing System	3-181
3-12	Troubleshooting - Hoist System.....	3-187
3-13	Troubleshooting - Counterweight System	3-191
3-14	Troubleshooting - Outrigger System	3-192
3-15	Troubleshooting - Heating System	3-196
4-1	Single Reduction Hypoid - Drive Unit Torque Limits	4-249
4-2	Single Reduction Drive Unit Torque Limits	4-275
4-3	Torque Valves.....	4-303

SECTION IV**CARRIER**

INTRODUCTION. (Illus. 4-1).

This section provides descriptive and maintenance information for the Carrier. The descriptive text describes the operation of the Carrier Components. When required, cutaway and block diagrams are provided to support the text. Also, maintenance information is provided to help personnel repair and service the Carrier. Descriptive and maintenance information for major optional equipment is given.

4-1 (4-2 blank)

DESCRIPTION. (Illus. 4-2).Controls, Gages and Indicators.

The items that follow identify the controls, gages, and indicators in the Carrier Cab. Also, the paragraphs specify the purpose of each control, indicator, and gage. The index numbers on the illustration correspond to the numbers in the paragraphs.

1. Remote Throttle Control. Controls operation of the Superstructure throttle. When in the ON position allows the Superstructure air throttle system to control engine rpm.
2. Voltmeter. Indicates the battery condition, when alternator is not producing electromotive force (volts). Also, shows condition of the charging system when engine is operating.
3. Engine Oil Pressure Gage. Normal operating pressures should remain in a range of 40 to 60 psi.
4. Engine Water Temperature Gage. Normal temperature indication should be in the range of 170 to 185°F. If temperature indication is abnormal, operation of automatic radiator shutters and/or the thermostat should be checked.
5. Engine Tachometer. Indicates revolutions per minute at which engine is operating.

Main Air System Pressure Gage. (Not Shown). Indicates pressure in main air tank. Operating range is normally between 95 and 125 psi. If pressure drops below 75 psi, a low pressure warning buzzer will operate and the red warning light will illuminate.

Fuel Gage. (Not Shown). Indicates fuel tank quantity in fractions of the total tank capacity.

6. Low Air Pressure Warning Light. This light activates simultaneously with the warning buzzer. If traveling, immediate stop should be made to avoid automatic application of spring brakes.
7. Speedometer and Odometer. Indicates road speed and total mileage vehicle has traveled.
8. Light Beam Indicator Light. Indicates whether lights are on LOW or HIGH beam.
9. Differential Lock Indicator Light. Indicates when the inter-axle differential control is in the LOCK position.
10. Inter-Axle Differential Control Lever. When positioned to LOCK engages (LOCK OUT) the inter-axle differential.
11. Cab Light Switch. Controls overhead light.

12. Hourmeter. Provides a digital readout of engine operating hours. Controlled by a pressure switch in the engine oil system.
13. Ignition On Indicator Light. Indicates that the ignition switch is positioned to ON or ACC.
14. Push-Pull Parking Brake Control. Pulling control button out releases air in the spring loaded automatic brake units on the rear tandem axles. Pushing button in compresses the springs, releasing the brakes. Do NOT use to stop vehicle except in an emergency as a severe sudden stop will occur.
15. Defroster Push-Pull Control. Pulling the control allows air from the heater to flow to the windshield for defrost. Pushing the control allows air to flow out of the heater vents into the cab.
16. Cab Heater Fan Control. Variable speed control adjusts air output as desired.
17. Heat Push-Pull Control. Pulling the control opens a valve in the heater inlet water line to control the temperature of the air.
18. Windshield Wiper Switch. This switch has three positions OFF LOW HIGH with built-in circuit breaker.
Parking Brake Warning Light. (Not Shown). When RED, indicates parking brake is "on".
19. Engine Emergency Stop Control. Used only when engine does not stop with normal ENGINE STOP CONTROL. This control shuts off the air supply at the engine air box for positive stop. The valve must be manually reset at the air box.
20. Engine Stop Button. Depressing button energizes a solenoid valve which places the injector racks in the "no fuel" position.
21. Ignition Switch. Provides for controlling electrical power to the Carrier and for starting the engine.
22. Lights Switch. Three position switch controls parking-marker lights, head-tail lights, and indirect instrument panel lights.
23. Hydraulic Pump Indicator Light. Indicates if the hydraulic pumps constant speed drive is engaged or disengaged.
24. Roadranger Gear Shift Lever. Shift pattern shown on decal.
Gear Range Selector Valve. (Not Shown). Range positions shown on shift lever knob and decal.
Countershaft Brake Control Button. (Not Shown). Used only to assist initial engagement when vehicle is standing still.
25. Accelerator Pedal. Controls engine speed by mechanical linkage to the governor control shaft. Depress to increase engine speed.

26. Air Brake Pedal. Controls air valve in line from air system tank to wheel air brakes. Because of light force required to actuate pedal, extreme care should be taken during initial familiarization.
27. Clutch Pedal. Hydraulic master and slave system provides easier clutch operation. First 1 1/2 inches of free pedal travel provides clutch release bearing clearance.
28. Windshield Washer Control. Bulb type located to the left of the clutch pedal. Non-freezing type windshield washer fluid should be used at all times.
29. High-Low Beam Light Switch. Conventional foot button type with high beam indicator on panel.
30. Directional Signal Switch. Push lever up for right turn indication and pull down for left indication. Lever will automatically return to neutral when wheels are straightened out after turn.

Quick Start Button. (Not Shown). Can only be energized while starter is held in "on" position.

Hazard Light Switch. (Not Shown). Move switch forward to actuate four-way flasher when required. Move switch backward for OFF.

Turn Signal Indicator. (Not Shown). Blinking light indicates turn switch is in signal position and signal lights are working properly.

Constant Speed Pump Drive Disconnect Handle. (Not Shown). Pulling handle disengages the constant speed pump drive.

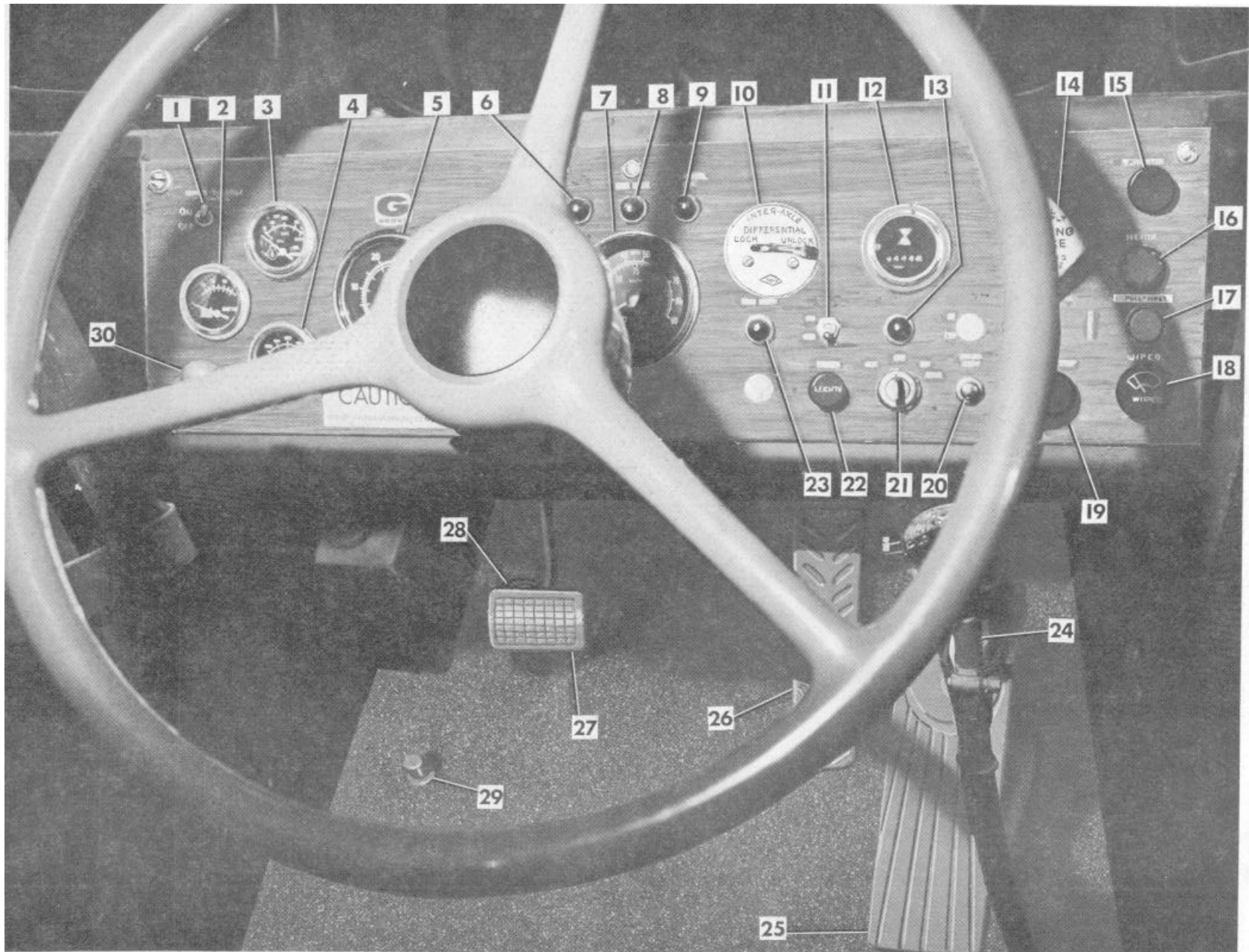

Illustration 4-2. Carrier Cab

DRIVE TRAIN.

Engine. (Illus. 4-3).

The GM6-71N Diesel Engine is standard. The GM6-71N Diesel Engine has 6 cylinders. The general specifications for the engine is listed below. The paragraphs to follow describe the Engine Systems that provide fuel, coolant, lubricating oil, electric, and air. For detailed descriptions, refer to IN-LINE 71 OPERATORS MANUAL.

General Specifications:

NUMBER OF CYLINDERS	6	TOTAL DISPLACEMENT CU. IN.	426
BORE	4 1/4 in.	FIRING ORDER R.H. ROTATION	1-5-3-6-2-4-
STROKE	5 in.	L.H. ROTATION	1-4-2-6-3-5
COMPRESSION RATIO	18.7 to 1		

Fuel System Components. (Illus. 4-4).

The Fuel System consists of fuel injectors, fuel piping, fuel pump, fuel strainer, and fuel filters. A restricted elbow is located in the outlet manifold to maintain pressure in the fuel system between the inlet and outlet fuel passages.

Fuel is drawn from the supply tank through the fuel strainer and enters the fuel pump at the inlet side. Upon leaving the pump under pressure, the fuel is forced through the fuel filter and into the fuel inlet manifold where it passes through fuel pipes into the inlet side of each fuel injector. The fuel is filtered through elements in the injectors and atomized through small spray tip orifices into the combustion chamber. Surplus fuel, returning from the injectors, passes through the fuel return manifold and connecting fuel lines back to the fuel tank.

The continuous flow of fuel through the injectors helps to cool the injectors and remove air from the fuel system.

A check valve may be installed between the fuel strainer and the source of supply as optional equipment to prevent fuel drain back when the engine is not running.

Fuel Injectors.

The fuel injector combines in a single unit all of the parts necessary to provide complete and independent fuel injection at each cylinder. The injector creates the high pressure necessary for fuel injection, meters the proper amount of fuel, atomizes the fuel, and times the injection into the combustion chamber.

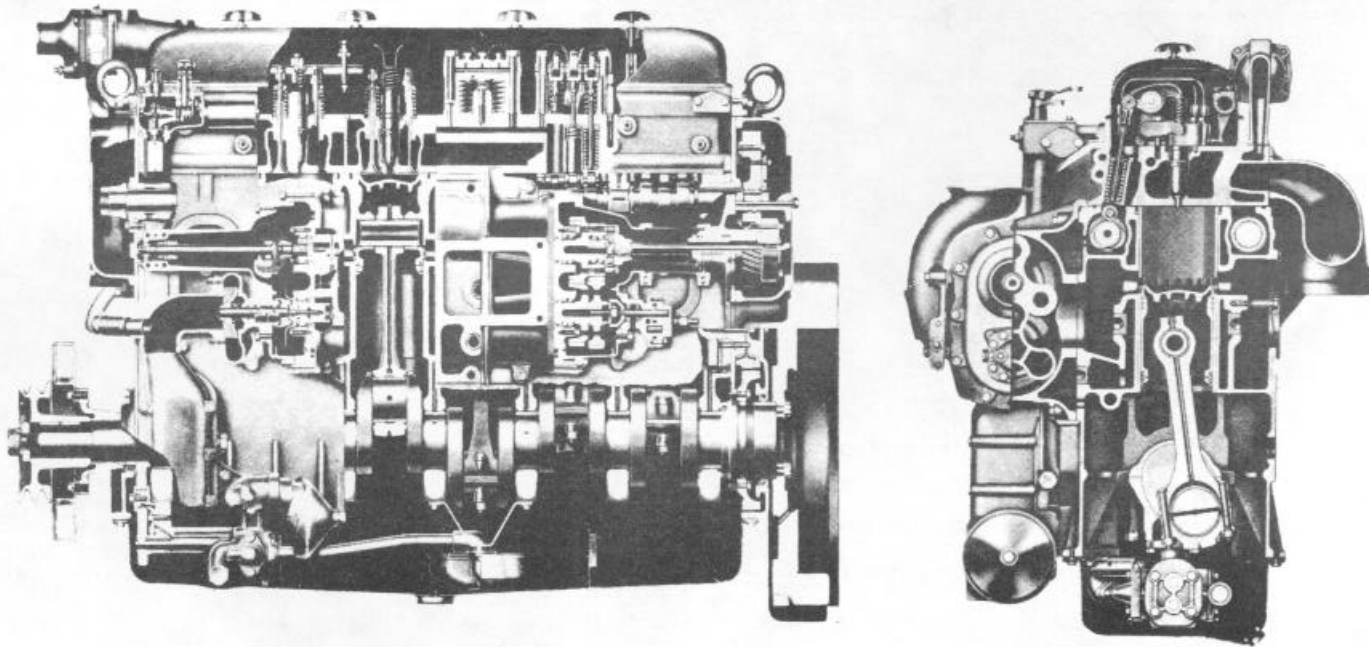
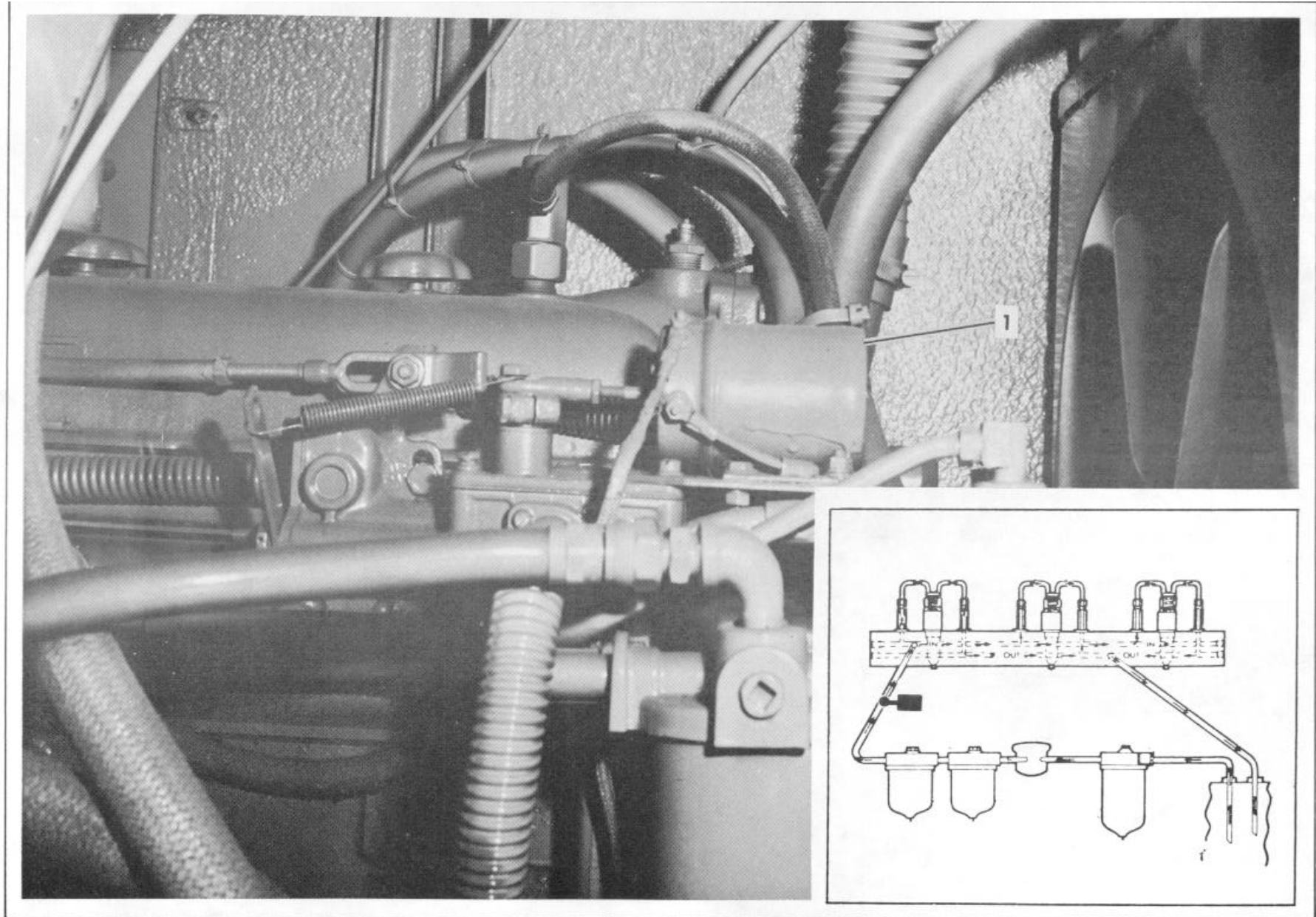
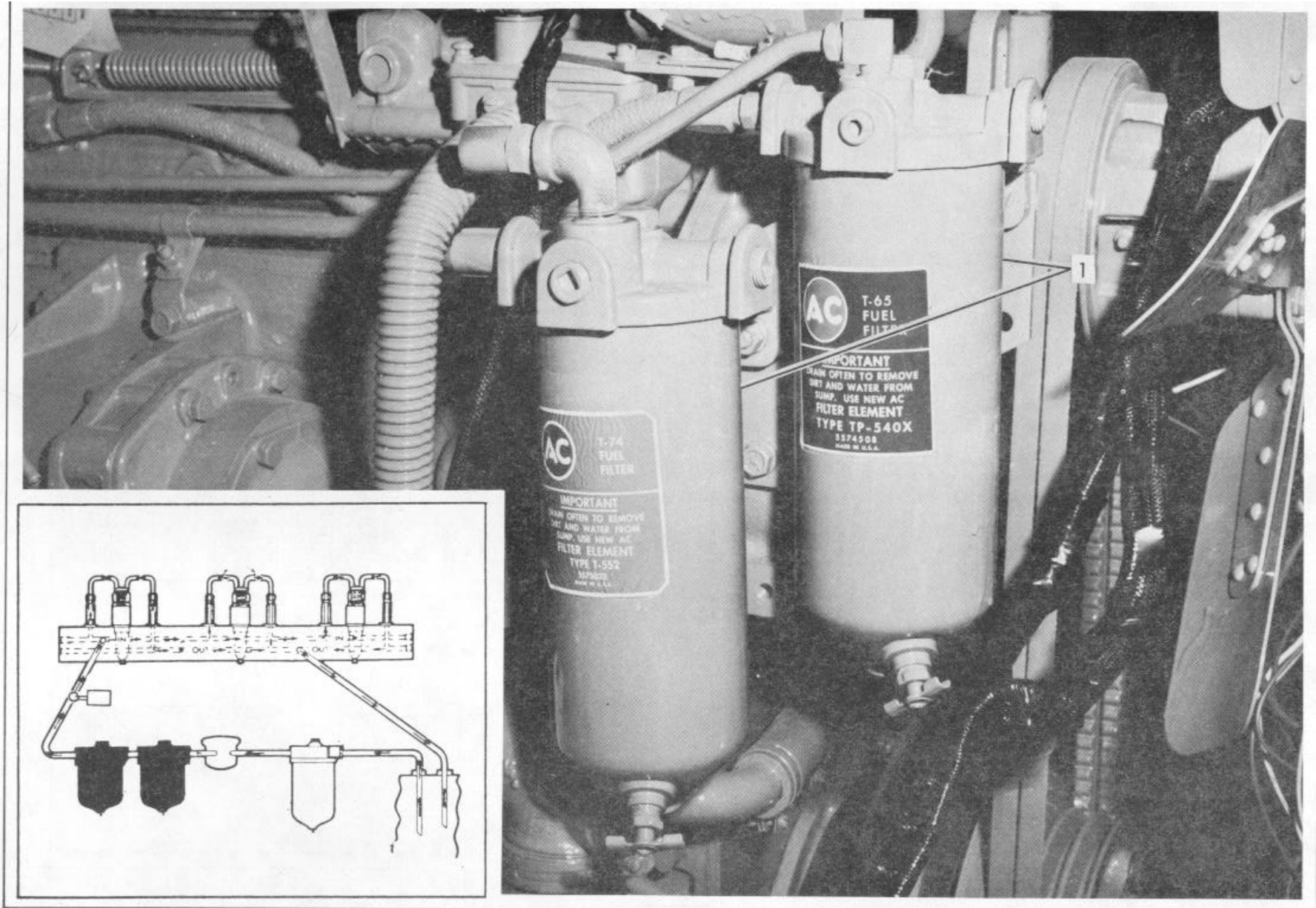

Illustration 4-3. Cross Section Views of Typical In-line Engine.



1. Fuel Stop Switch

Illustration 4-4. Engine Fuel System Components. (Sheet 1 of 4)



1. Fuel Filter

Illustration 4-4. Engine Fuel System Components. (Sheet 2 of 4)

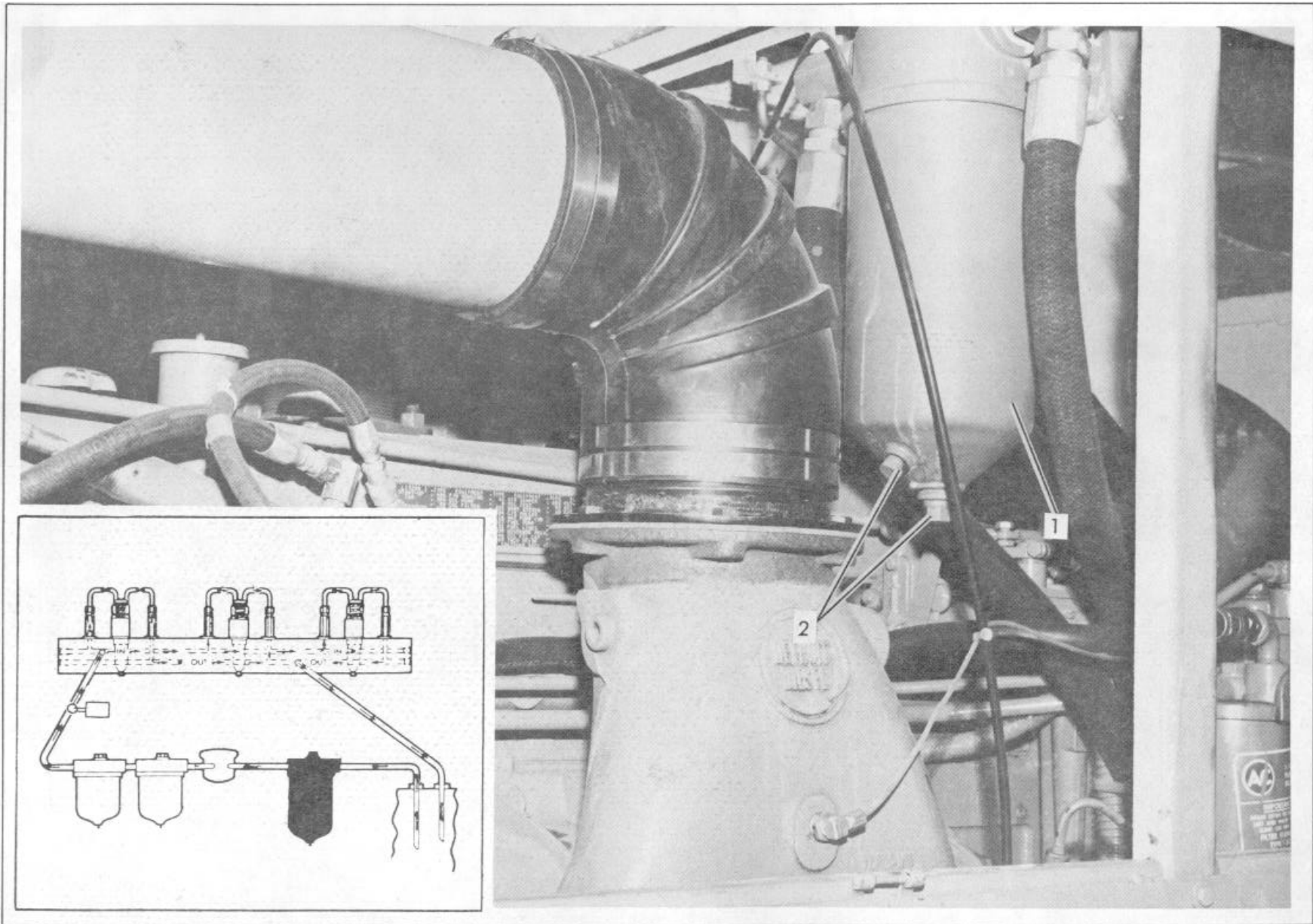

- 1. Fuel Strainer
- 2. Drains

Illustration 4-4. Engine Fuel System Components. (Sheet 3 of 4)

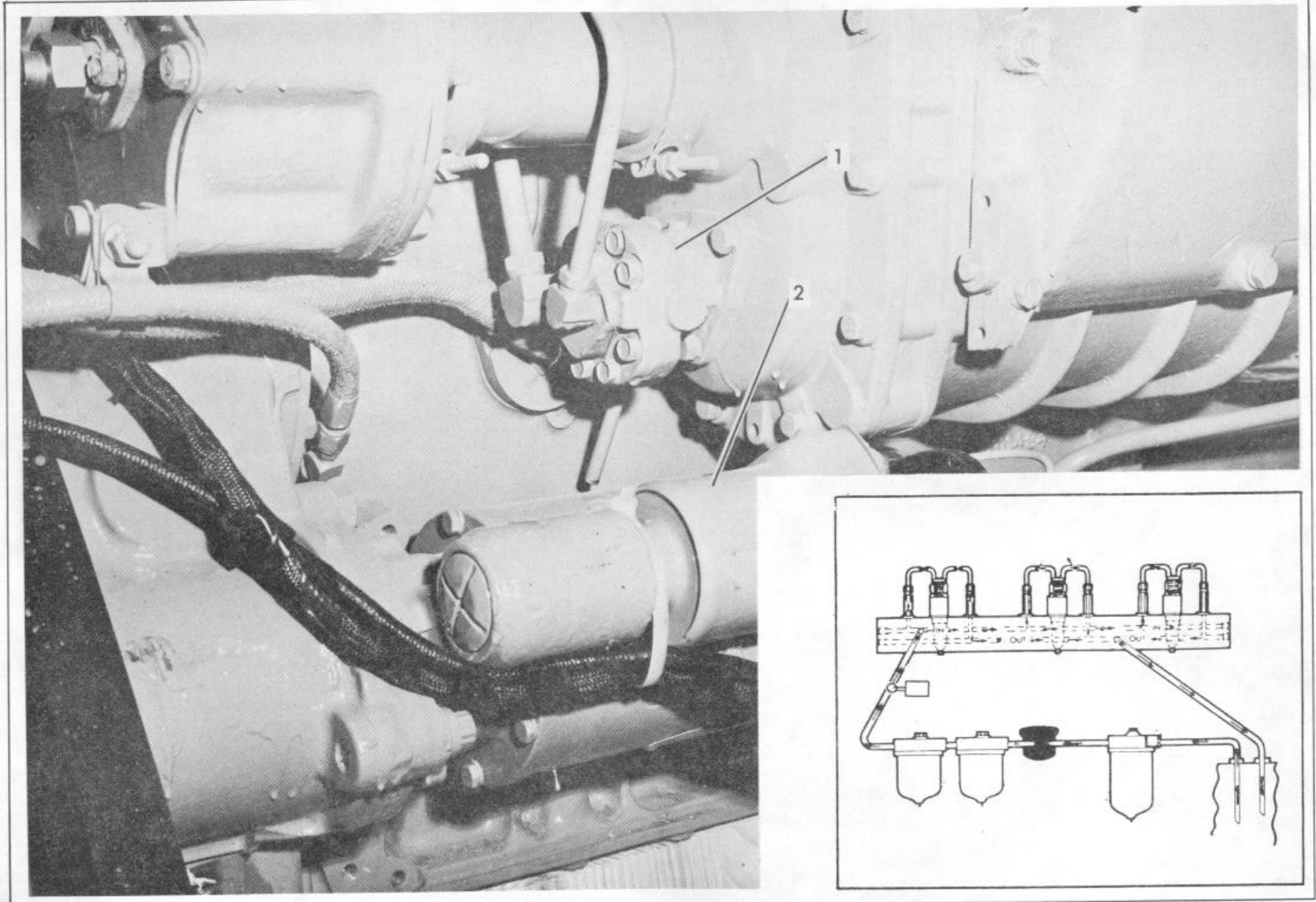

- 1. Fuel Pump
- 2. Starter

Illustration 4-4. Engine Fuel System Components. (Sheet 4 of 4)

Fuel Pump.

A positive displacement gear type fuel pump is attached to the blower and driven off the rear end of the lower blower rotor.

A spring-loaded relief valve, incorporated in the pump body, normally remains in the closed position, operating only when the pressure on the outlet side (to the fuel filter) becomes excessive due to a plugged filter or fuel line.

The fuel pump incorporates two oil seals. Two tapped holes are provided in the underside of the pump body, between the oil seals, to permit a drain tube to be attached. If fuel leakage exceeds one drop per minute, the seals must be replaced.

Fuel Strainer and Fuel Filter.

A replaceable element type fuel strainer and fuel filter are used in the fuel system to remove impurities from the fuel. The strainer removes the larger particles and the filters remove the small particles.

The fuel strainer and fuel filters are basically identical in construction, both consisting of a cover, shell and replaceable element. Since the fuel strainer is placed between the fuel supply tank and the fuel pump, it functions under suction; the fuel filters, which is installed between the fuel pump and the fuel inlet manifold in the cylinder head, operates under pressure.

Fuel Stop Switch.

Depressing the engine stop button in the cab allows power to energize the fuel stop switch. The fuel stop switch actuates a solenoid that places the injector racks in the no fuel position.

Engine Air System Components. (Illus. 4-5).

A charge of air, forced into the cylinders by the blower, sweeps all of the exhaust gases out through the exhaust valve ports, leaving the cylinders filled with fresh air for combustion at the end of each upward stroke of the pistons.

This air also helps cool the internal engine parts, particularly the exhaust valves. At the beginning of the compression stroke each cylinder is filled with fresh, clean air which provides for efficient combustion.

The blower supplies fresh air required for combustion and scavenging. Two hollow three-lobe rotors are closely fitted in the blower housing which is bolted to the cylinder block. The revolving motion of these rotors pulls fresh air through the air cleaner or air silencer and provides a continuous and uniform displacement of air in each combustion chamber. The continuous discharge of fresh air from the blower creates a pressure in the air box.

Air Cleaner.

The air cleaners are the heavy duty dry type. The dry type air cleaner consists of a removable cover attached to the air cleaner body which contains a replaceable paper filter cartridge and a dust cap. Air entering the air cleaner is given a centrifugal pre-cleaning by a turbine type vane assembly. Air rotates at high speed around the filter element throwing the dust to the outside where it flows.

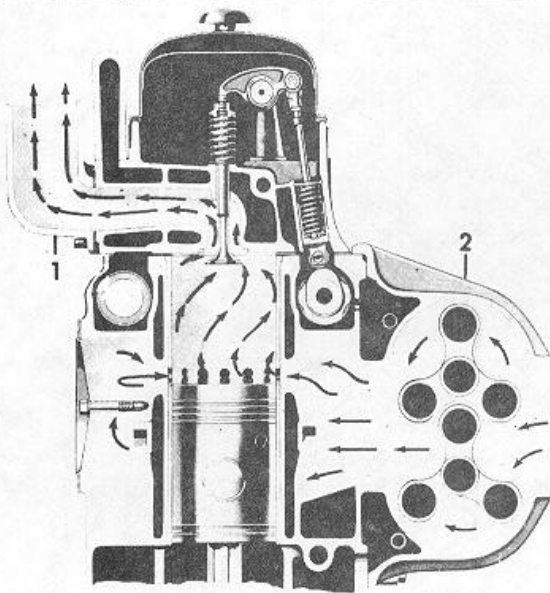

A

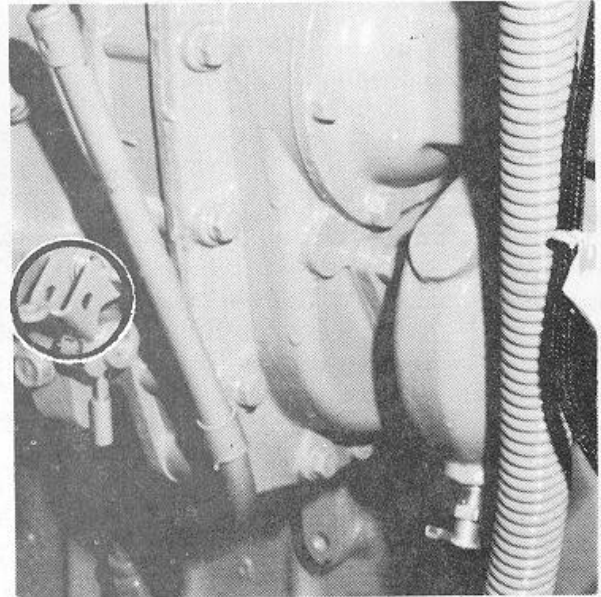

B



C

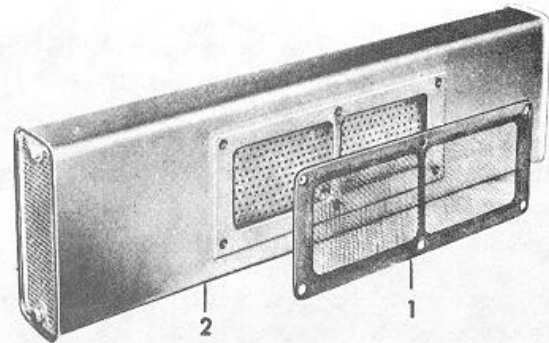

D

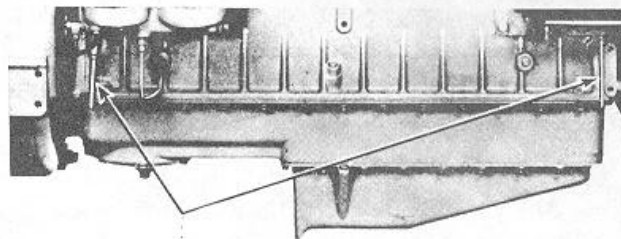

E

- | | | | | |
|---------------------|------------------------------|----------------|------------------|----------------|
| A. Engine Air Flow | B. Manual Air Shut-off Valve | C. Air Cleaner | D. Drain Box | E. Air Box |
| 1. Exhaust Manifold | | | 1. Blower Screen | 1. Drain Tubes |
| 2. Blower | | | 2. Silencer | |

Illustration 4-5. Engine Air System Components

down the wall of the body and is ejected into a dust cap. The dust cap is baffled to prevent re-entry of dust. The pre-cleaned air passes through the paper filter and enters the engine.

Air Box Drains.

During normal engine operation water vapor from the air charge, as well as a slight amount of fuel and lubricating oil fumes, condenses and settles on the bottom of the air box. This condensation is removed by the air box drain tubes mounted on the side of the cylinder block.

The air box drains must be open at all times. With the engine running, a periodic check is recommended for air flow from the air box drain tubes. Liquid accumulation on the bottom of the air box indicates a drain tube may be plugged. Such accumulations can be seen by removing the cylinder block air box cover(s) and should be wiped out with rags or blown out with compressed air. Then remove the drain tubes and connectors from the cylinder block and clean them thoroughly.

Crankcase.

Harmful vapors which may form within the engine are removed from the crankcase, gear train, and injector compartment by a continuous, pressurized ventilation system.

A slight pressure is maintained within the engine crankcase and injector compartment by the seepage of a small amount of air past the piston rings.

Crankcase ventilation is accomplished by the air seepage past the piston rings sweeping up through the flywheel housing and balance weight cover into the valve and injector rocker arm compartment where it is expelled through a vent pipe attached to the rocker cover or the governor. Certain engines use a breather attached to the side of the cylinder block.

Manual Air Shut-Off Valve.

In an emergency, a emergency stop knob located in the cab may be pulled to stop the engine. The emergency stop knob, when pulled, will trip the air shut-off valve located between the air inlet housing and the blower and shut off the air supply to the engine. Lack of air will prevent further combustion of the fuel and stop the engine.

The emergency stop knob must be pushed back in after the engine stops so the air shut-off valve can be opened for restarting after the malfunction has been corrected.

Lubricating System Components.(Illus. 4-6).

This lubricating system consists of an oil pump, oil cooler, a full-flow oil filter, by-pass valves at the oil cooler and filter and pressure regulator valves at the pump and in the cylinder block main oil gallery. Positive lubrication is ensured at all times by this section. A by-pass oil filter may also be incorporated into the lubricating system.

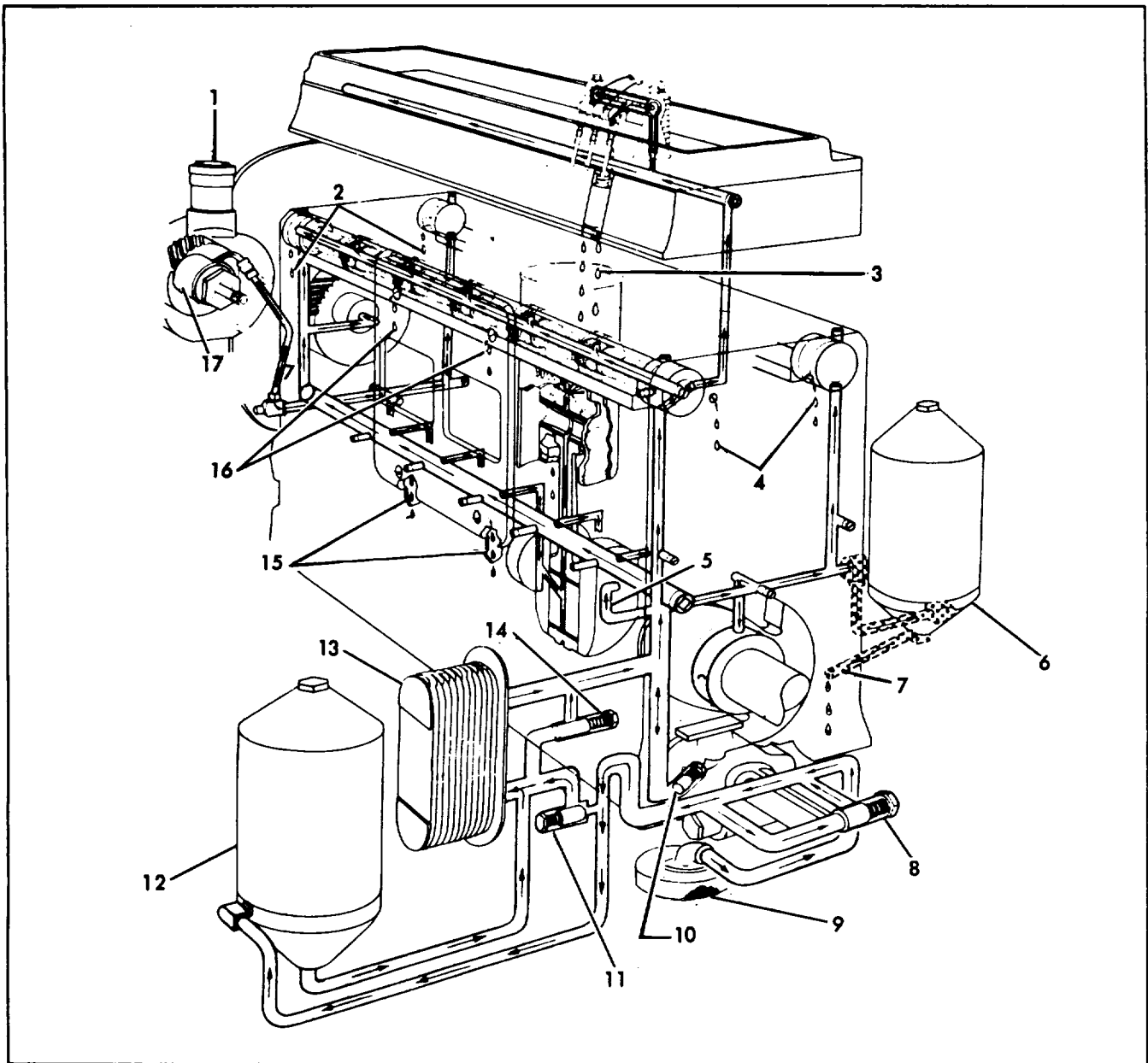

1. Oil Filter
2. Cam Pocket Drain
3. Drain to Cam Pockets
4. Cam Pocket Drain
5. Oil Line to Governor
6. By-Pass Filter
7. Drain to Oil Pan
8. 105 P.S.I. Safety Valve in Oil Pump
9. Inlet Screen
10. 50 P.S.I. Oil Pressure Regulator Valve
11. 15 P.S.I. Diff. Pressure Filter By-Pass Valve
12. Full Flow Filter
13. Oil Cooler
14. 40 P.S.I. Diff. Pressure Oil Cooler By-Pass Valve
15. Oil Drain From Blower
16. Oil Drain to Blower
17. Oil From Main Gallery

Illustration 4-6. Engine Lubricating System Components.

Oil for lubricating the connecting rod bearings, piston pins, and for cooling the piston head, is provided through the drilled hole in the crankshaft from the adjacent forward main bearings. The gear train is lubricated by the overflow of the oil from the camshaft pocket through a connecting passage into the flywheel housing. A certain amount of oil spills into the flywheel housing from the camshaft, balance shaft, and idler gear bearings. The blower drive gear bearing is lubricated through an external pipe from the rear horizontal oil passage of the cylinder block.

Oil from the cam pocket enters the blower and overflows through two holes, one at each end of the blower housing, providing lubrication for the blower drive gears at the rear end, and for the governor mechanism at the front.

Oil Filters.

Engines are equipped with a full-flow type, lubricating oil filter. If additional filtering is required, a by-pass oil filter may also be installed.

The full-flow filter assembly can be remotely mounted or mounted on the engine. A by-pass valve, which opens at 18 to 21 psi, is located in the filter adaptor to ensure engine lubrication in the event the filter should become plugged.

All of the oil supplied to the engine passes through the full-flow filter that removes the larger foreign particles without restricting the normal flow of oil.

The by-pass filter assembly, when used, continually filters a portion of the lubricating oil that is being bled off the oil gallery when the engine is running. Eventually all the oil passes through the filter, filtering out minute foreign particles that may be present.

Some engines may be equipped with a by-pass filter assembly consisting of two filter elements, each enclosed in a shell which is mounted on a single adaptor. An oil passage in the filter adaptor connects the two annular spaces surrounding both filter elements.

Low Oil Pressure Switch.

A low oil pressure switch is on the engine. When a low oil pressure condition exists, the pressure switch sends a electrical signal to the low oil pressure indicator located in the cab.

Cooling System Components. (Illus. 4-7).

The engine coolant is drawn from the bottom of the radiator core by the water pump and forced through the oil cooler and into the cylinder block. The coolant circulates up through the cylinder block into the cylinder head, then to the water manifold and thermostat housing. From the thermostat housing, the coolant returns to the radiator and passes down a series of tubes, and is cooled by the air stream created by the fan.

When starting a cold engine or when the coolant is below operating temperature, the coolant is restricted at the thermostat housing and a by-pass tube provides water circulating within the engine during the warm-up period.

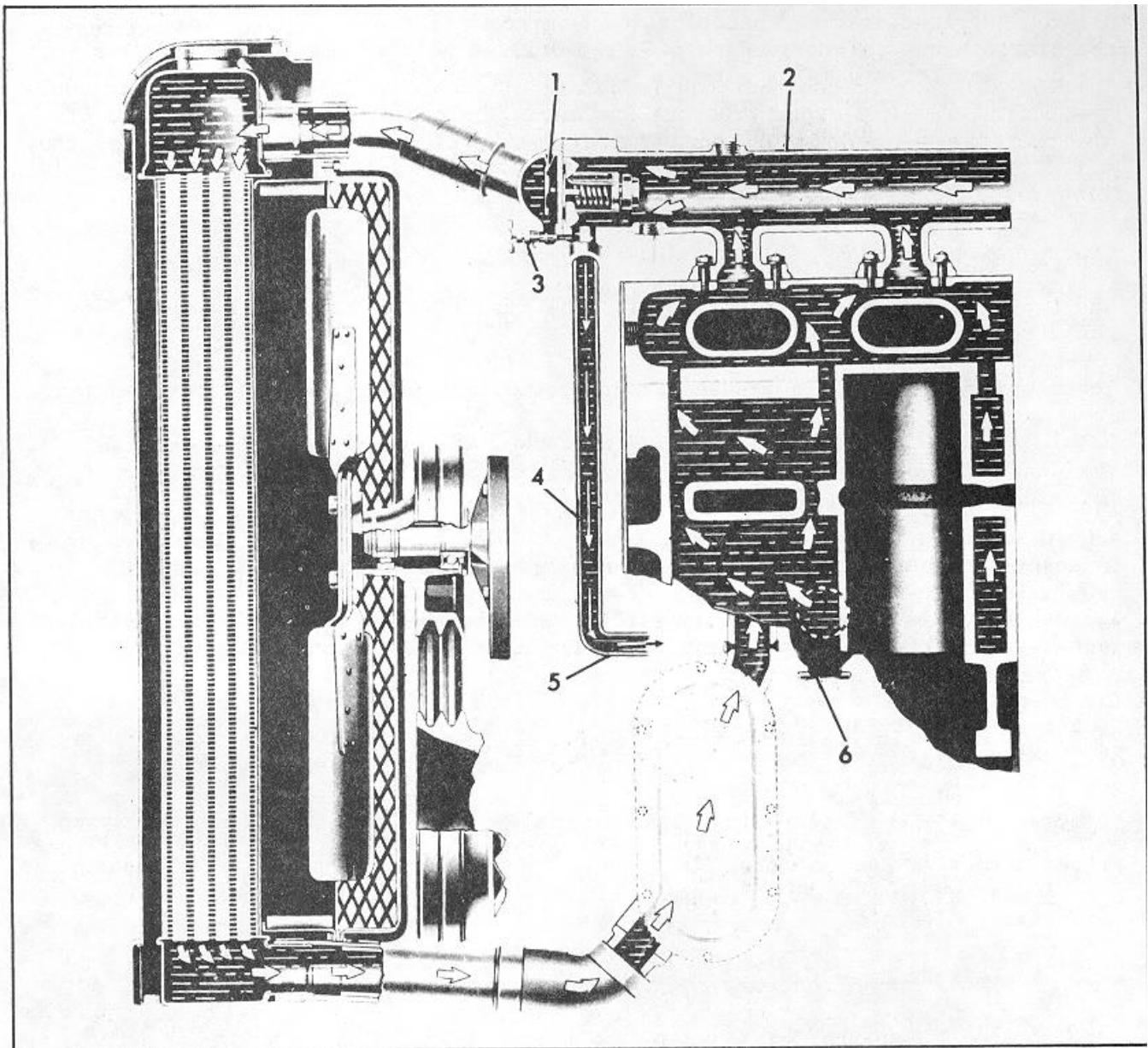

Illustration 4-7. Engine Cooling System Components.

Air Oil Cooler.

Mounted in front of the radiator is an air oil cooler. The air oil cooler cools the oil used by the Superstructure Systems. The cooler is mounted forward of the radiator. Air drawn across the radiator by the engine fan flows across the air-oil cooler and cools the oil returning to the Superstructure hydraulic oil reservoir.

Transmission RTO-613. (Illus. 4-8 and 4-9).

The transmission used is the RTO613T. The transmission has 13 forward speeds and 3 reverse speeds.

These units consist of a 5 speed front section and a 3 range auxiliary section.

Rotors in the front section are used once through intermediate range of the auxiliary and once through direct range. This provides a simple repeat shift pattern.

A transmission countershaft brake is mounted on the gear shift. When the countershaft brake button and the clutch are depressed air flows to the countershaft brake in the transmission. This locks the countershaft assemblies and the main shaft stops turning. This braking device should be used when the Carrier is standing still.

All speeds are controlled with one lever. The range selection is made with a 3-position selector valve mounted on top of the gear shift lever.

When in "low" and "intermediate" the control valve shuts off the air supply to the end cap. Thus, the constant air entering at the constant supply port forces the piston to the rear. The constant air also flows through a channel in the center of the piston and to an external port which is aligned with the low range port of the air valve.

When in "direct" the control valve opens and supplies air to the end cap. Since the piston area is larger on this end of the piston, it is forced in the opposite direction. The exhaust air port in the piston is now aligned with the direct range port of the air valve.

The twin countershaft design, splits torque evenly between two countershafts, reducing gear tooth pressure and wear. The floating main shaft gears of this design eliminate gear bushings and sleeves as gears "float" between mating gears on the countershafts.

Listed below are the RTO-613T specifications.

Speeds - 13 forward, 3 reverse.

Torque Capacity - 600 lb.-ft.

Clutch Housing Size - SAE No. 2, gray iron, deep only, 6-5/8", for push or pull type clutches.

Power Take-off -

Openings: Two SAE standard for 6/8 pitch gears.

Right Side: Regular duty type, 6 bolt. PTO shaft projections limited.

Bottom Side: Heavy duty type, 8 bolts.

PTO Gear Speeds -

Right and Bottom: 33-tooth 6/8 pitch gears turning at .723 engine speed.

Weight - 620 lbs.

Length - 34-11/16" from face of clutch housing to end of splines on tail shaft.

The gears within the transmission are changed by a gearshift lever..

The remote shift control unit includes the gearshift lever and tower (master control unit), the shift control housing assembly (slave unit) and shift control shaft. The master control unit is mounted to the chassis so that the lever will protrude into the cab Just beside the drivers seat. The shift control housing assembly is mounted on the transmission shaft bar housing, where the shift fingers from the housing engage the shift bars and blocks. The shift control shaft transmits motion of the gearshift lever to the shift bar housing and the shift fingers inside the transmission.

Safety Neutral Switch.

Mounted on top of the transmission is a Safety Neutral Switch. The switch prevents engine start up from the Superstructure Cab when the transmission is in gear. Lockout of the start system is through the start relay.

Back-Up Lamp Switch.

Mounted on the transmission next to the slave unit is the Back-Up Lamp Switch. When the transmission is shifted into reverse a circuit is complete to the Carrier Back-Up Light and lights the light.

RT0613 GEAR RATIOS

	Ratio	% Step
	.80	25
	1.00	29
Direct Range	1.29	28
	1.65	27
	2.11	
Range Shift		28

RT0613 GEAR RATIOS

	Ratio	% Step
	2.65	
		24
	3.29	
		29
Intermediate Range	4.24	
		28
	5.43	
		28
Range Shift	6.96	
		27
	8.83	
		28
	11.31	
		28
Low Range	14.50	

Slave Air Valve.

When in "low" and "intermediate" the control valve shuts off the air supply to the end cap. Thus, the constant air entering at the constant supply port forces the piston to the rear. The constant air also flows through a channel in the center of the piston and to an external port which is aligned with the low range port of the air valve.

When in "direct" the control valve opens and supplies air to the end cap. Since the piston area is larger on this end of the piston, it is forced in the opposite direction. The external air port in the piston is now aligned with the direct range port of the air valve.

Air Regulator and Filter Assembly.

The air regulator output should be 57 to 62 psi.

Range Control Valve.

There are four ports in the bottom of the control.

1. "S" port is the supply port and is the constant air lines from the air valve.
2. "E" port is the exhaust port and is left open.
3. "R" port is the signal line to the air valve.
4. "F" is the signal line to the intermediate shift cylinder.

Intermediate Shift Cylinder.

Constant, regulated air is channeled through the cover to the front side of shift piston - air is always on this side of piston. The shift piston is moved by removing or applying air (from constant supply) to the backside of piston. This piston area is

larger and can overcome area of front side of piston. The removal or application of air on backside of piston is controlled by the insert valve in cylinder cover; this valve in turn is controlled by the range control valve.

The insert valve located in the shift cylinder cover is a small 1-3/16" Humphrey valve. It is installed with the flat surface to the inside towards the center port, and it is secured with a special nut in bottom bore of cover.

The insert valve is self-contained and can not be disassembled except for the three O-rings on outer diameter. These three O-rings are a stationary seal and do not move in cylinder.

Travel of the small piston in the insert valve is only 3/16". The insert valve is a normally-open valve. Thus, when there is no signal or delivery of air to top side of insert piston, the constant air from regulator passes through the insert valve and to the backside of the piston and moves the shift bar forward (low range).

When the insert valve piston is activated by a signal or delivery of air, the insert valve is closed and shuts off the constant air to backside of shift piston. Air in shift cylinder is exhausted out through insert valve and bottom bore of cover.

When air is removed from backside of shift piston, constant air on front side of shift piston moves the shift bar to the rear (intermediate and direct range). Clutch and Actuating System. (Illus. 4-10).

Actuating System.

The operation of the Lipe Direct Pressure clutch (DLB) is as follows: The clutch flywheel ring (cover) is attached to the engine flywheel and drives the pressure plate by means of driving lugs in the flywheel ring (cover) and mating slots in the pressure plate.

Depressing the clutch pedal disengages the clutch, by allowing the release bearing to contact and move the release levers toward the engine flywheel resulting in the pressure springs being compressed and the pressure plate being retracted away from the disc assembly; thereby disengaging the clutch.

Releasing the clutch pedal engages the clutch by allowing the release bearing and release levers to move away from the engine flywheel and the pressure springs to expand and exert pressure against the pressure plate, resulting in the disc assembly being gripped between friction surfaces of engine flywheel and pressure plate; thereby completely engaging the clutch.

Clutch.

The Lipe type (direct pressure) clutches are precision built heavy duty units incorporating few parts. These clutch assemblies require no maintenance other than maintaining release bearing clearance which is accomplished by normal linkage adjustment.

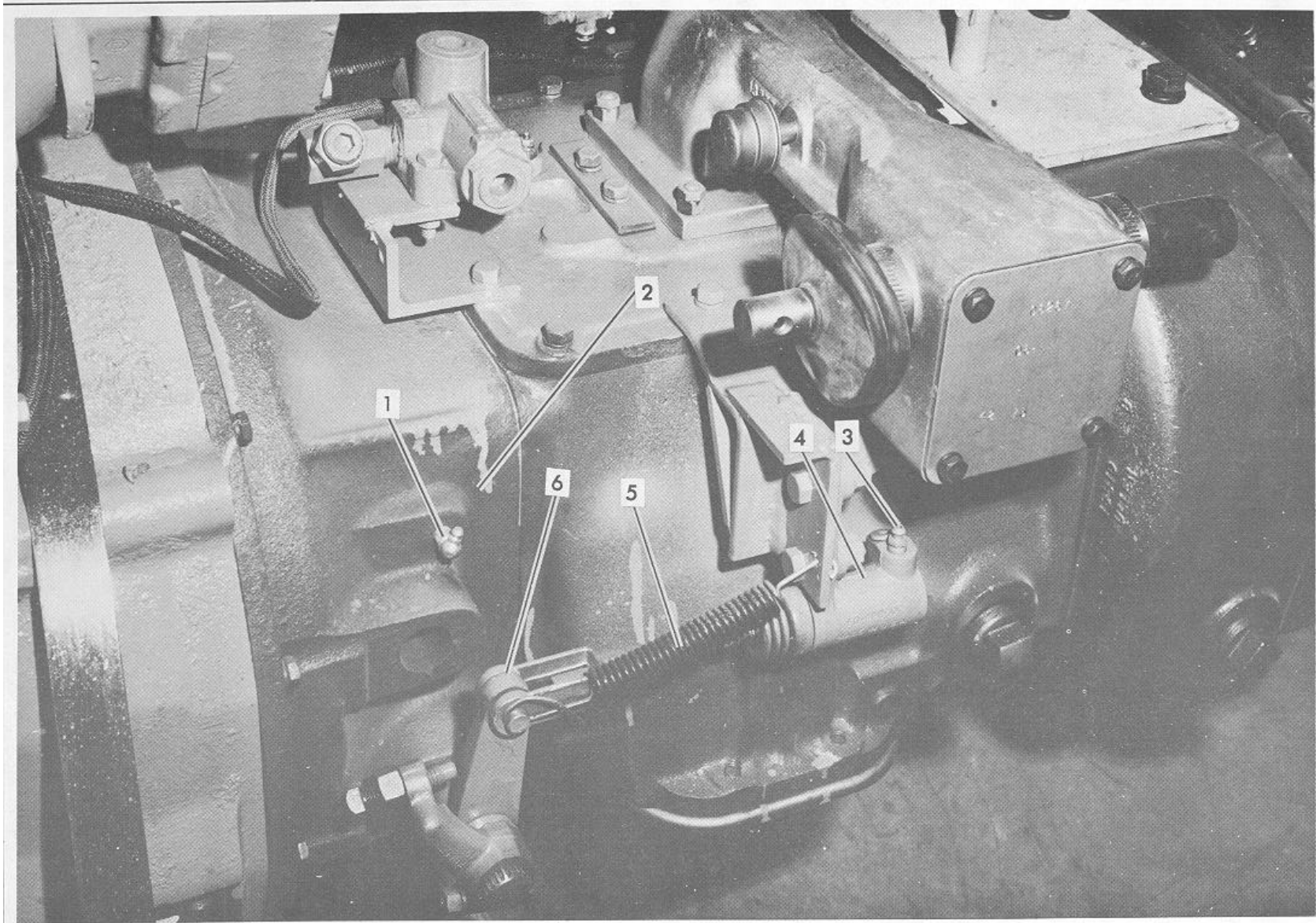

- | | |
|-----------------------|-------------------|
| 1. Lube Fitting | 4. Slave Cylinder |
| 2. Clutch Assembly | 5. Spring |
| 3. System Bleed Valve | 6. Linkage |

Illustration 4-10. Clutch Components (Sheet 1 of 2)

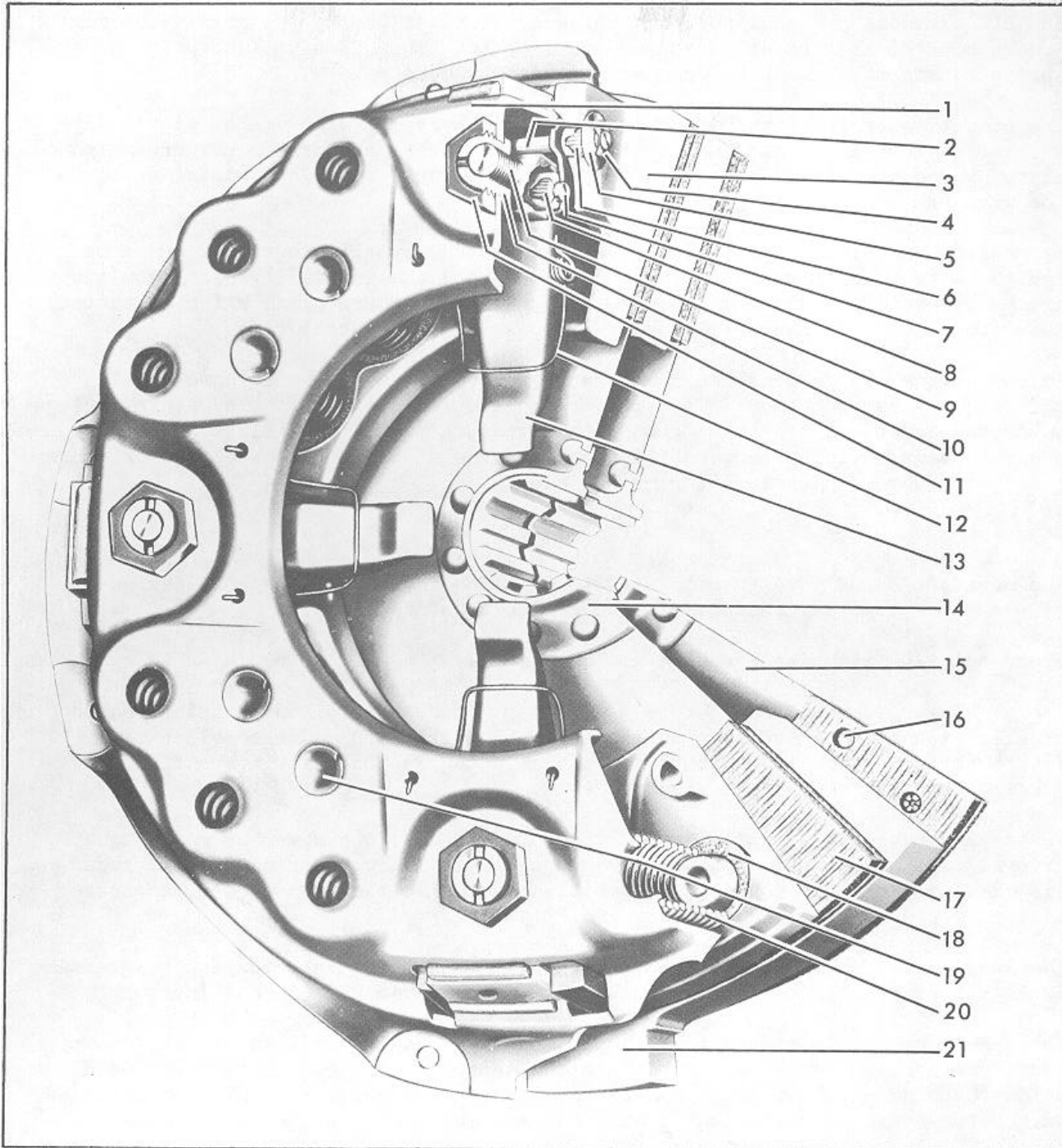

- | | |
|----------------------------|--|
| 1. Flywheel Ring (Cover) | 12. Retractor Spring |
| 2. Pressure Plate Pin | 13. Release Lever |
| 3. Pressure Plate Assembly | 14. Disc Assembly, Pressure Plate Side |
| 4. Retaining Ring | 15. Disc Assembly, Flywheel Side |
| 5. Washer | 16. Facing Rivet |
| 6. Needle Bearing | 17. Facing |
| 7. Eyebolt Pin | 18. Insulating Washer |
| 8. Needle Bearing | 19. Spring Retainer |
| 9. Eyebolt Assembly | 20. Pressure Spring |
| 10. Adjusting Nut | 21. Intermediate Plate |
| 11. Lock Nut | |

Illustration 4-10. Clutch Components (Sheet 2 of 2)

The DLB clutches are equipped with hardened steel drive lugs to afford the maximum amount of area to drive the pressure plate. The DLB also incorporates spring retainers. The DLB type used is with two plates.

The operation of the Lipe Direct Pressure clutch is as follows: The clutch fly-wheel ring (cover) is attached to the engine flywheel and drives the pressure plate by means of driving lugs in the flywheel ring (cover) and mating slots in the pressure plate.

Depressing the clutch pedal disengages the clutch, by allowing the release bearing to contact and move the release levers toward the engine flywheel resulting in the pressure springs being compressed and the pressure plate being retracted away from the disc assembly; thereby disengaging the clutch.

Releasing the clutch pedal engages the clutch by allowing the release bearing and release levers to move away from the engine flywheel and the pressure springs to expand and exert pressure against the pressure plate, resulting in the disc assembly being gripped between friction surfaces of engine flywheel and pressure plate; thereby completely engaging the clutch.

Constant Speed Pump Drive. (Illus. 4-11).

The constant speed pump that is used to drive the hydraulic pumps is engine driven. The pump is connected to the engine by a drive shaft.

Front Axle and Steering System. (Illus. 4-12).

Front Axles. Rockwell-Standard's non-driving front axles incorporating sealed knuckle pins and permanently lubricated (sealed) tie-rod end assemblies have less maintenance requirements than front axle models employing conventional knuckle pins and tie-rod end assemblies.

The sealed type knuckle pins are of the straight design and may or may not be grooved depending on the type of bushing employed. Knuckle pins of this type also employ two flats for correct positioning inside the axle center, and are held in place by tapered dowel keys.

The lubricant is protected within the knuckle from road contamination by grease seals and gaskets that enclose the upper and lower knuckle pin bushings.

The upper bushing is sealed from the top by a gasket located beneath the upper knuckle pin cap. It is protected from the bottom by a grease seal positioned below the bushing, inside the upper knuckle boss. The lower bushing is enclosed on the top by the thrust bearing and seal assembly, and on the bottom by a gasket positioned between the lower knuckle boss and the lower knuckle pin cap. Some models may employ an integral gasket in the lower seal or thrust bearing.

Steering knuckles are bushed in the upper and lower knuckle pin bosses with steel backed bronze bushings.

Many front axle models employing sealed knuckle pins also incorporate enlarged steering knuckle assemblies (oversized

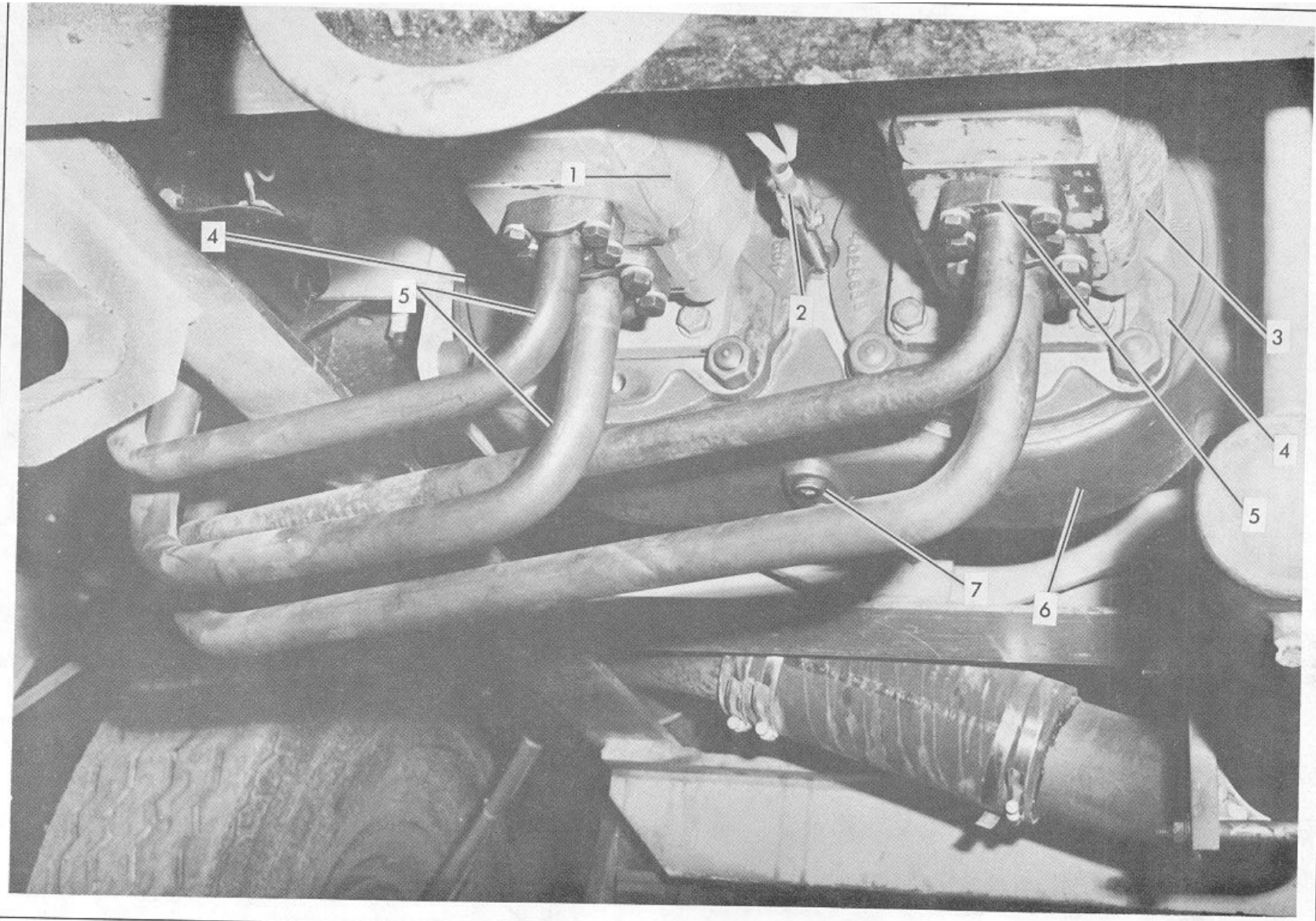

- | | |
|---|---|
| 1. Hydraulic Pump | 5. Hydraulic Lines Mounting Plate |
| 2. Mechanical Linkage (Pump Engage and Disengage) | 6. Constant Speed Pump Drive |
| 3. Hydraulic Pump | 7. Constant Speed Pump Drive Drain Plug |
| 4. Constant Speed Pump Drive | |

Illustration 4-11. Constant Speed Pump Drive.

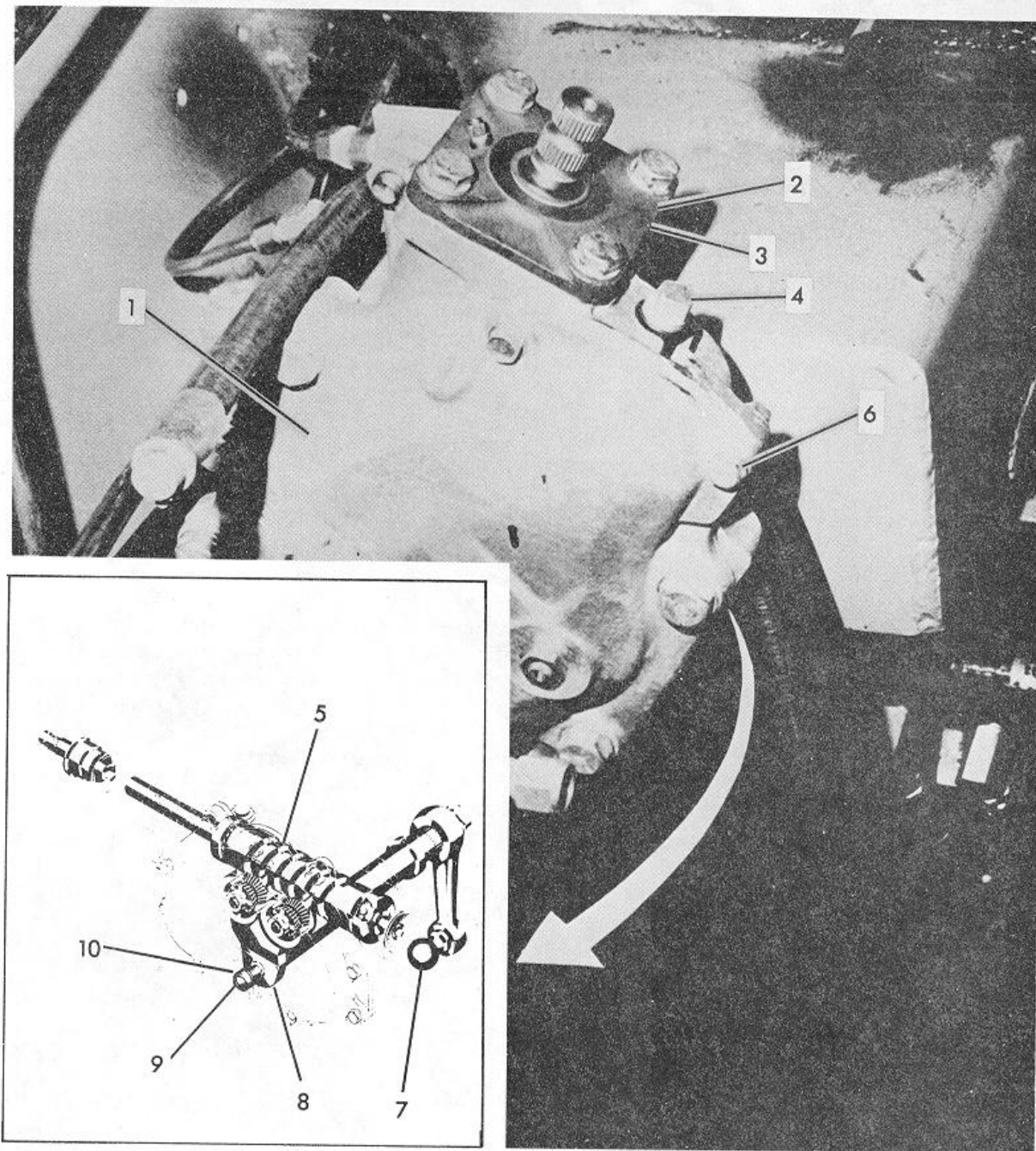

- | | | | | |
|----------------|--------------------|----------|-----------------|--------------------|
| 1. Steer Gear | 3. Adjusting Shims | 5. Cam | 7. Steering Arm | 9. Adjusting Screw |
| 2. Upper Cover | 4. Fill Plug | 6. Studs | 8. Lower Shaft | 10. Lock Nut |

Illustration 4-12. Steer Gear

for specific applications). These assemblies will include larger steering knuckles with stronger knuckle yokes, longer knuckle pins and longer knuckle pin bushings. This will slightly increase the over-all track of the front axle assembly, but more significantly, it will reduce bushing stress.

Steering knuckle caps for front axles employing sealed knuckle pins are equipped with top and bottom mounted grease fittings. This allows lubricants to be forced into the bushing area through the top and bottom ends of the steering knuckle and, therefore, provide a more even distribution of lubricants for easier steering.

Permanently lubricated tie rod end assemblies also employ lube seals that are designed to keep road contaminants from the tie-rod cavity. This will prevent lubrication contamination due to the accumulation of corrosion and dirt around the tie rod ball, and thus give longer service life. Since these tie rod end assemblies are permanently lubricated and sealed, periodic lube intervals are not necessary.

Steering Gear.

The Steering Gear used is a Ross TR70. The steering gear is a semi-reversible cam and twin lever type. Both studs of the twin lever engage the cam for normal straight ahead driving. As the steering action moves away from the normal driving position into the parking range, one of the studs disengages the cam. The effective leverage of this single stud increases so rapidly, however, that in full parking the leverage is 45 percent greater than with a single lever type of steering gear. This is due largely to the fact that because of the twin levers the steering arm is shorter and therefore has a full 100 degrees of travel compared to 76 degrees in a single lever unit. Actually the driver has at his disposal a dual ratio which automatically changes from one ratio to suit the requirements of steering stability at high speeds and easy wheel turn for sharp turns in parking. A valuable safety factor is a lessening of the tendency to over-steer on curves and when passing other vehicles at high speeds.

Power Steering System. (Illus. 4-13).

Steering of the Carrier is accomplished through the Power Steering System. The System consists of a reservoir, pump, flow control and relief valve, control valve and drag linkage and two 2 3/4" diameter steering cylinders.

Fluid for power steering is pumped by a 8 GPM pump that is engine driven. The fluid is pumped from the power steering reservoir. The fluid flows from the pump to the flow control and relief valve. The flow control and relief valve controls the fluid flow to 7 GPM. The fluid is routed from the flow control and relief valve to the steering control valve. The steering control valve directs the fluid to the cylinders. When the steering wheel is turned in either direction, the action is transferred to the steering gear. The steering gear contains a cam that is connected to a lever shaft. As the cam turns the lever shaft transfers the action to the steering arm. The steering arm actuates the control valve of the Power Steering System.

If power steering is lost for any reason, the operator is capable of steering the Carrier manually. For detailed description of the steering gear, refer to Steering Gear Description.

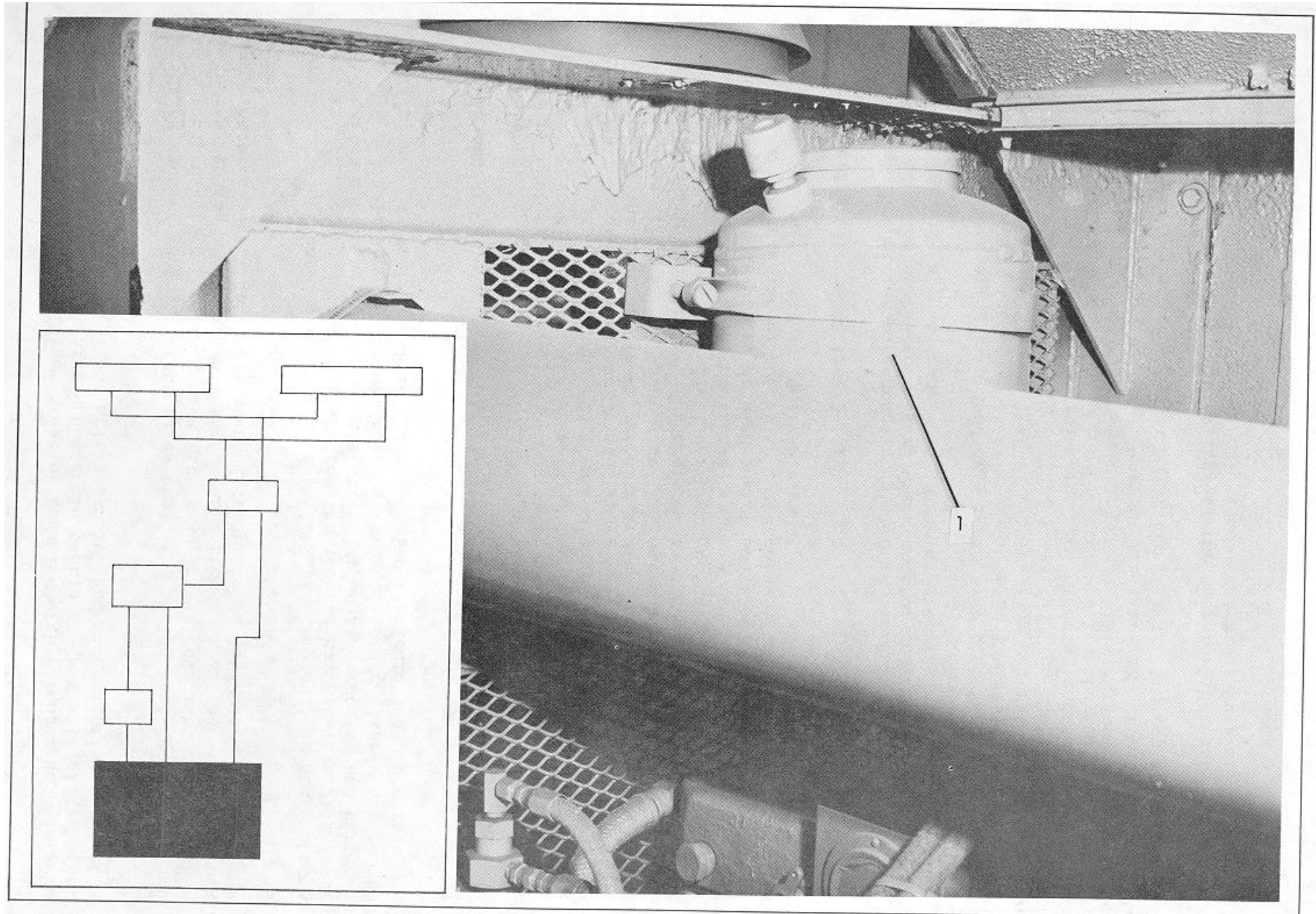

1. Power Steer Reservoir

Illustration 4-13. Power Steering System. (Sheet 1 of 4)

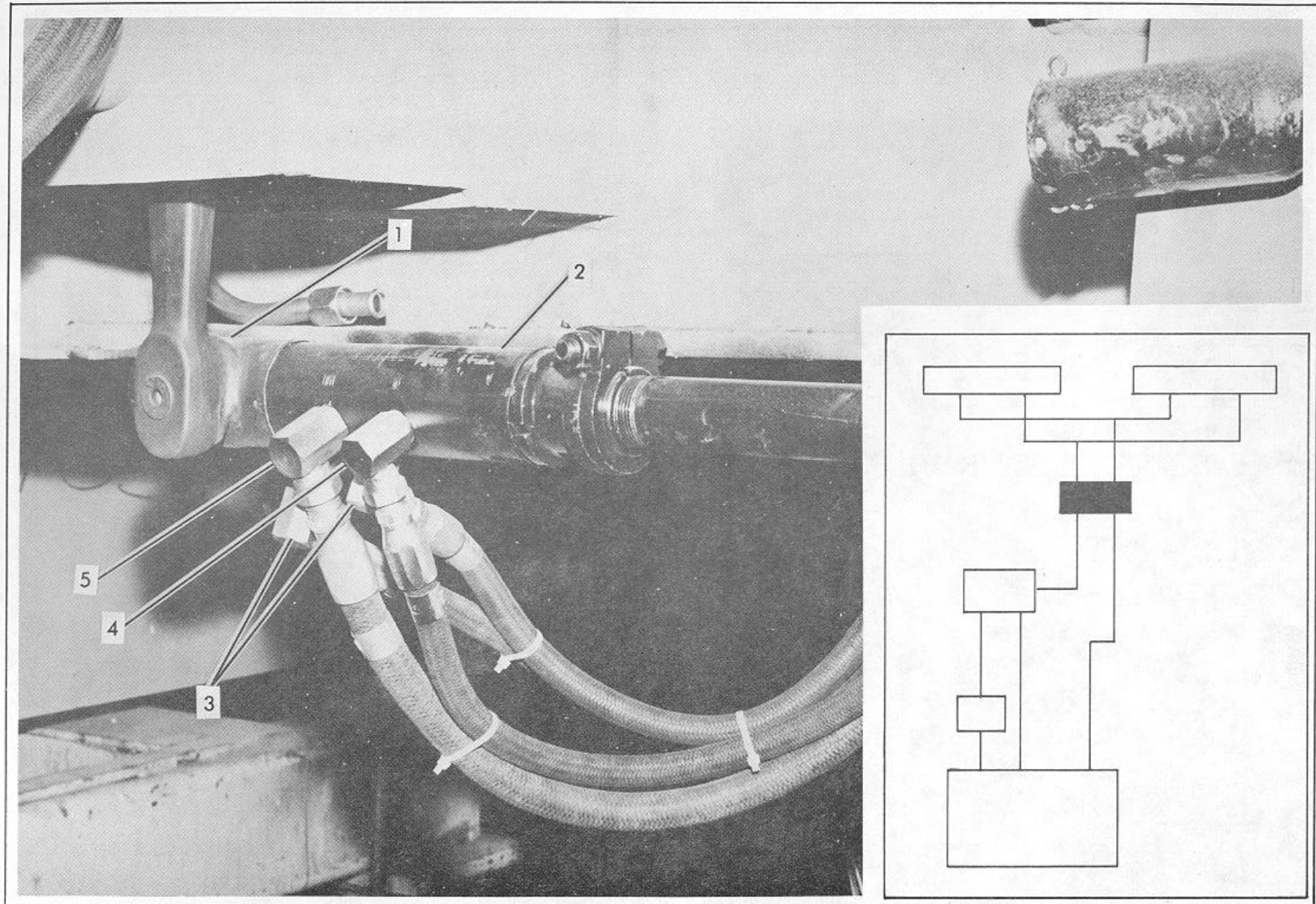

- 1. Steer Control Valve Inspection Hole
- 2. Steer Control Valve
- 3. Oil line to Stear Cylinders

- 4. Oil Line to Pump
- 5. Oil Line to Reservoir

Illustration 4-13. Power Steering System. (Sheet 2 of 4)

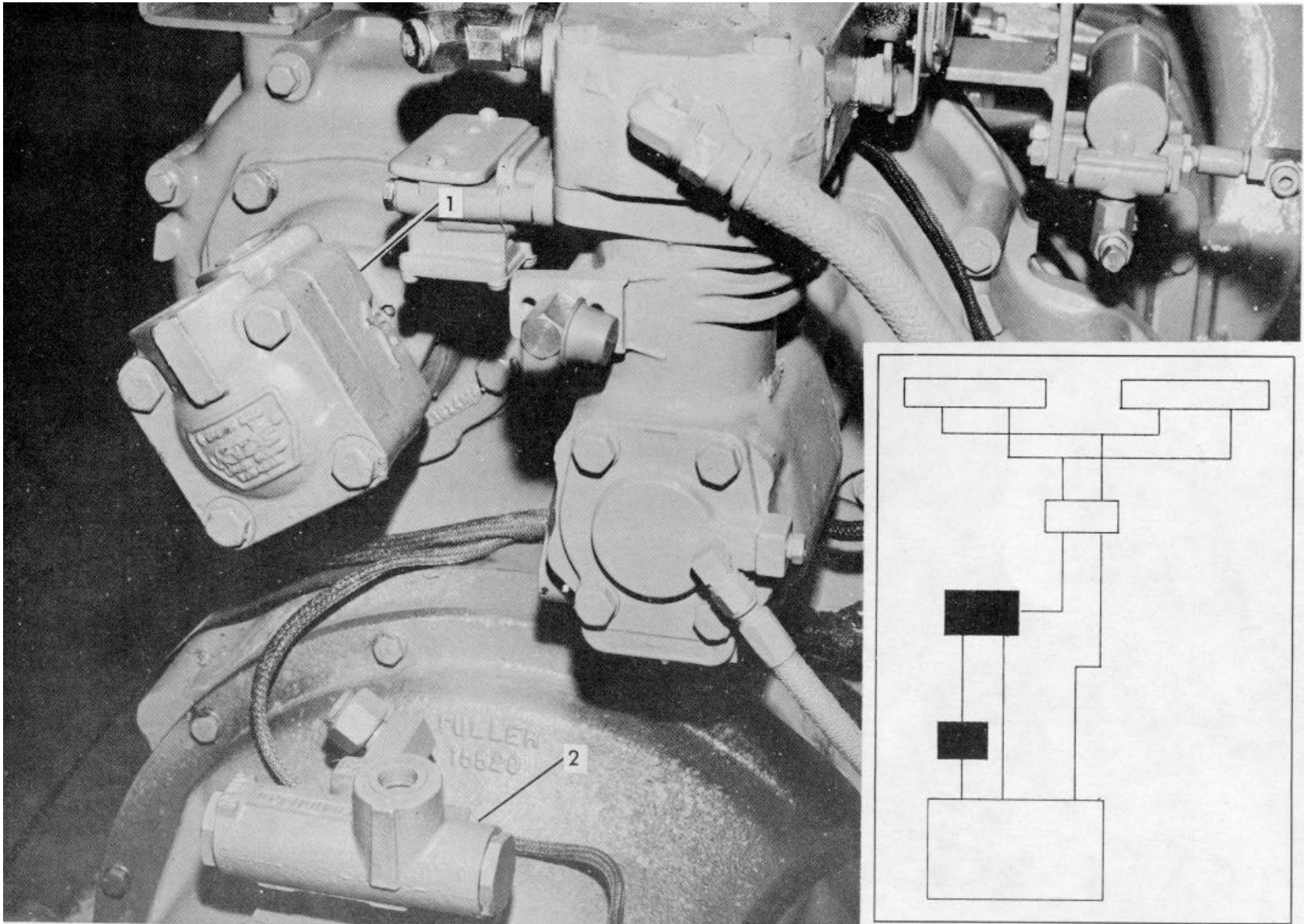

- 1 Power Steer Pump
- 2. Flow Control Valve

Illustration 4-13. Power Steering System (Sheet 3 of 4)

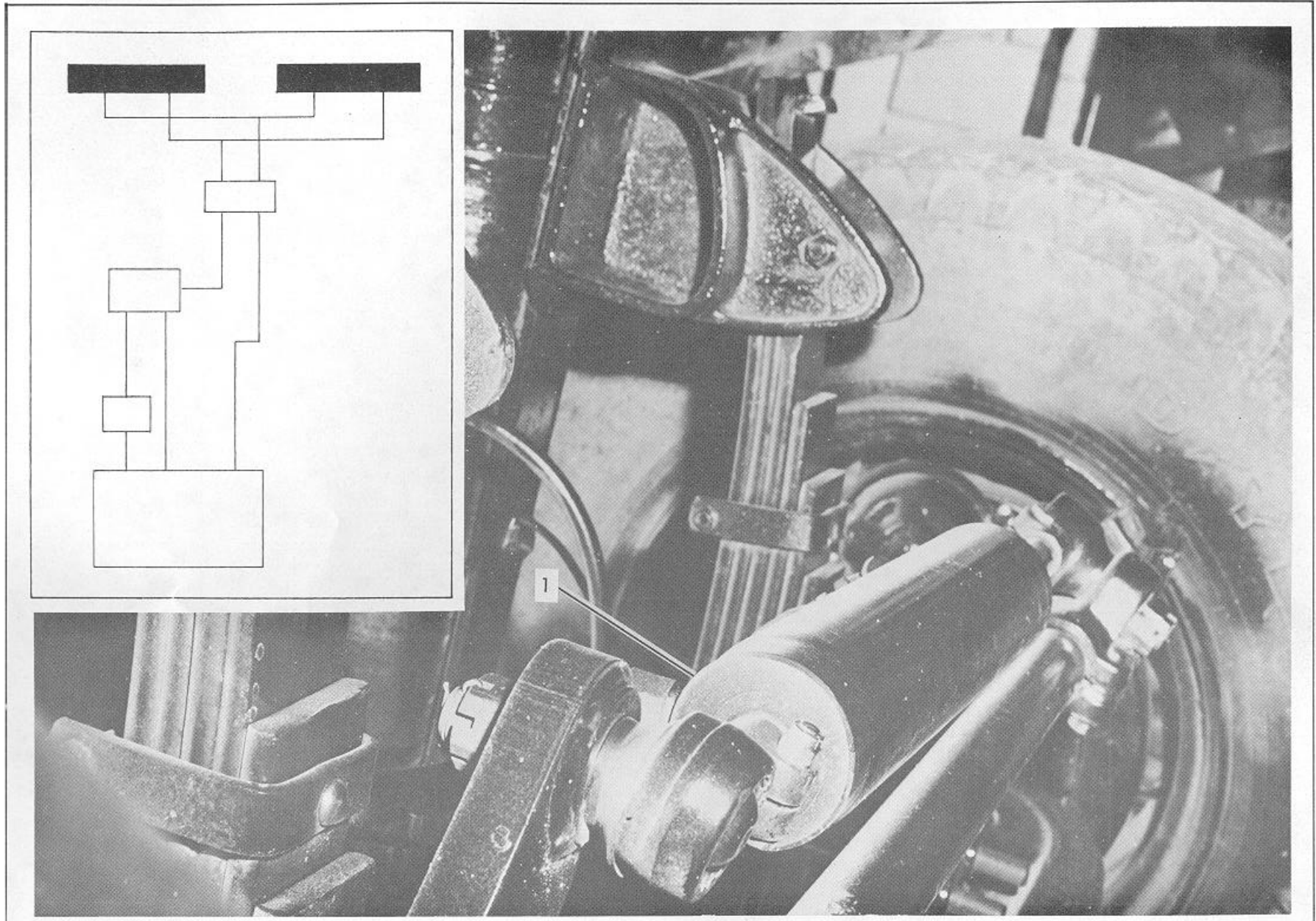

1. Steer Cylinder

Illustration 4-13. Power Steering System. (Sheet 4 of 4)

4-39 (4-40 blank)

Steering Control Valve.

Turning effort applied to the steering wheel of the vehicle actuates the steering control valve, which in turn directs hydraulic fluid from the pump directly to the cylinder located in the steering linkage.

The valve piston is centered automatically by the hydraulic force against the reaction rings. When the operator's effort at the steering wheel exceeds the hydraulic force at the reaction ring, the control valve is actuated and the hydraulic power is provided for power steering.

Whenever the valve piston is in center (neutral) position the oil pressure at the cylinder ports of the valve is low. Under this condition there is no circulation of oil through the lines to the power cylinder. The oil is circulating, however, from the pump, through the valve and to the reservoir with sufficient pressure only to overcome the resistance due to friction in the valve, lines, and fittings.

When the effort in turning the steering wheel of the vehicle overcomes the centering effect of the force against the reaction rings the valve piston is moved axially to restrict the flow of oil to one of the cylinder ports. At the same instant, the passage in the second cylinder port is opening thus causing an immediate increase in pressure in one of the ports at the power cylinder which supplies power for steering.

While the oil under pressure is entering one end of the cylinder, the oil from the discharge end of the cylinder is returning through the first cylinder port in valve and into the return port, back to the reservoir.

Full pressure in the steering system is obtained with a valve piston travel of about thirty-five thousandths (.035) of an inch. The slightest movement of the piston however, causes a pressure differential at the valve cylinder ports. When the effort at the steering wheel is released the valve piston returns to center position.

Whenever the steered wheels are subjected to shock loads the movement of the steering linkage tends to actuate the valve in the drag link momentarily. This action moves the valve piston axially in the appropriate direction thereby diverting the hydraulic fluid to the proper side of the power cylinder piston to resist the forces of tie shock. This blocking action prevents "kickbacks" at the steering wheel and stabilizes the steering.

Power Steering Pump.

The power steering pump is capable of pumping power steering fluid to the system. The pump is engine driven, and produces 8 GPM at 1200 RPM. The pump is of the gear type with a drive gear assembly and driven gear assembly. A flow control and relief valve is in the pump.

Flow Control Valve and Relief Valve. The primary purpose of the Flow Control and Relief Valve is to limit fluid flow (7 GPM) to the steering control valve.

The valve contains a relief valve that senses system pressure. If the pressure within the system exceeds 1500 PSI the relief valve cracks and a pressure difference is created across the main control spool in the valve. The pressure difference moves the spool, and a passage back to the power steering reservoir is opened. Excess fluid passes to the reservoir.

Single Reduction Hypoid-Drive Unit. (Illus. 4-14).

Front-mounted Single Reduction Through Drive Type Drive Units with a two-gear transfer train built by Rockwell-Standard incorporate hypoid reduction gears and bevel type gears in the inter-axle differential assembly. This unit differs from other Rockwell-Standard front-mounted through' drive type drive units by the omission of an idler shaft and the corresponding gear within the transfer gear train. Correct rotation of the hypoid reduction gears is accomplished in the de-sign of the unit by simply cutting both gear and pinion with the opposite (R.H.) spiral angel and mounting the gear on the opposite side of the pinion as compared to other through drive type drive units.

The input shaft is mounted on two ball bearings mounted in the single-piece carrier and cap assembly. The through-shaft is splined to the rear of the inter-axle differential assembly and is supported by a ball bearing in a rear bearing cage located in the housing.

An air operated axle lockout valve is in the air system. The valve when actuated to the lockout position from the Carrier Cab allows air flow to an inter-axle differential shift unit. The air pressure shifts a sliding dog clutch collar on the input shaft. The dog clutch engages corresponding teeth on the forward portion of the input transfer drive gear. With the inter-axle differential lock up, both axles are forced to turn at the same speed regardless of slippage on one axle.

Single Reduction Drive Unit. (Illus. 4-15).

The Rockwell-Standard Single-Reduction Final Drive employs a heavy duty spiral bevel or hypoid pinion and gear. The differential and gear assembly is mounted on tapered roller bearings. The straddle mounted pinion has two tapered roller bearings in front of the pinion teeth which take the forward and reverse thrust and a third bearing behind the piston teeth to carry the radial load.

Single-Reduction Final Drives are available in a wide range of gear ratios and sizes to cover most operating conditions.

Universal Joints and Drive Shafts. (Illus. 4-16).

To transmit required loads, the drive shaft must possess high strength. Forged steel, or high strength cast yokes are generally used to provide necessary strength and the rigidity required to maintain bearing alignment under torque loads and during high speed operation. Special high-strength tubing is used to provide maximum torque carrying capacity at minimum practical weight. This tubing must be securely welded to its end members, to provide the necessary torque capacity.

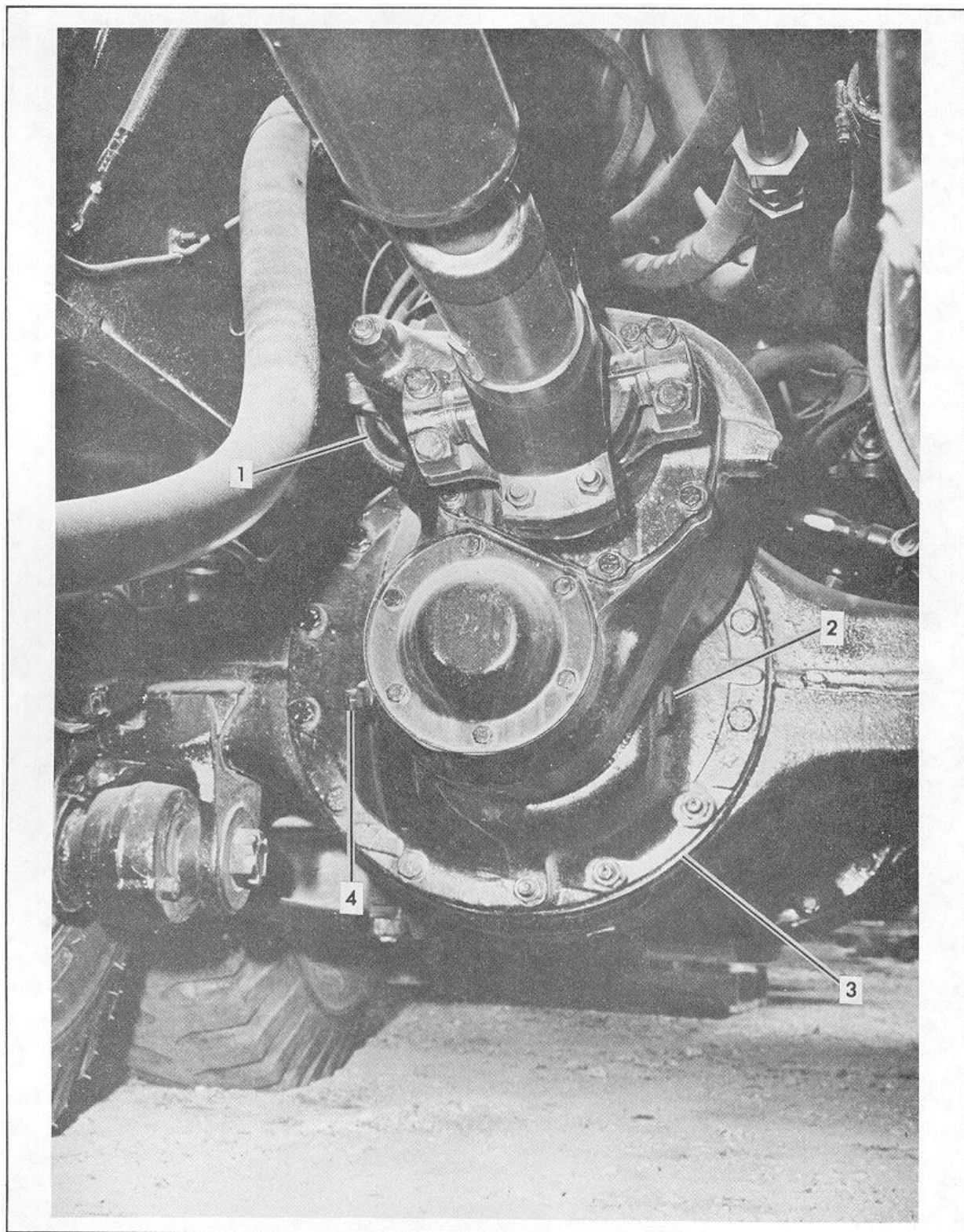

- | | |
|--------------------|---------------------------------------|
| 1. Shift Unit | 3. Single-Reduction Hypoid-Drive Unit |
| 2. Lube Check Plug | 4. Thrust Block Adjusting Screw |

Illustration 4-14. Single Reduction Hypoid Drive Unit. (Sheet 1 of 3)

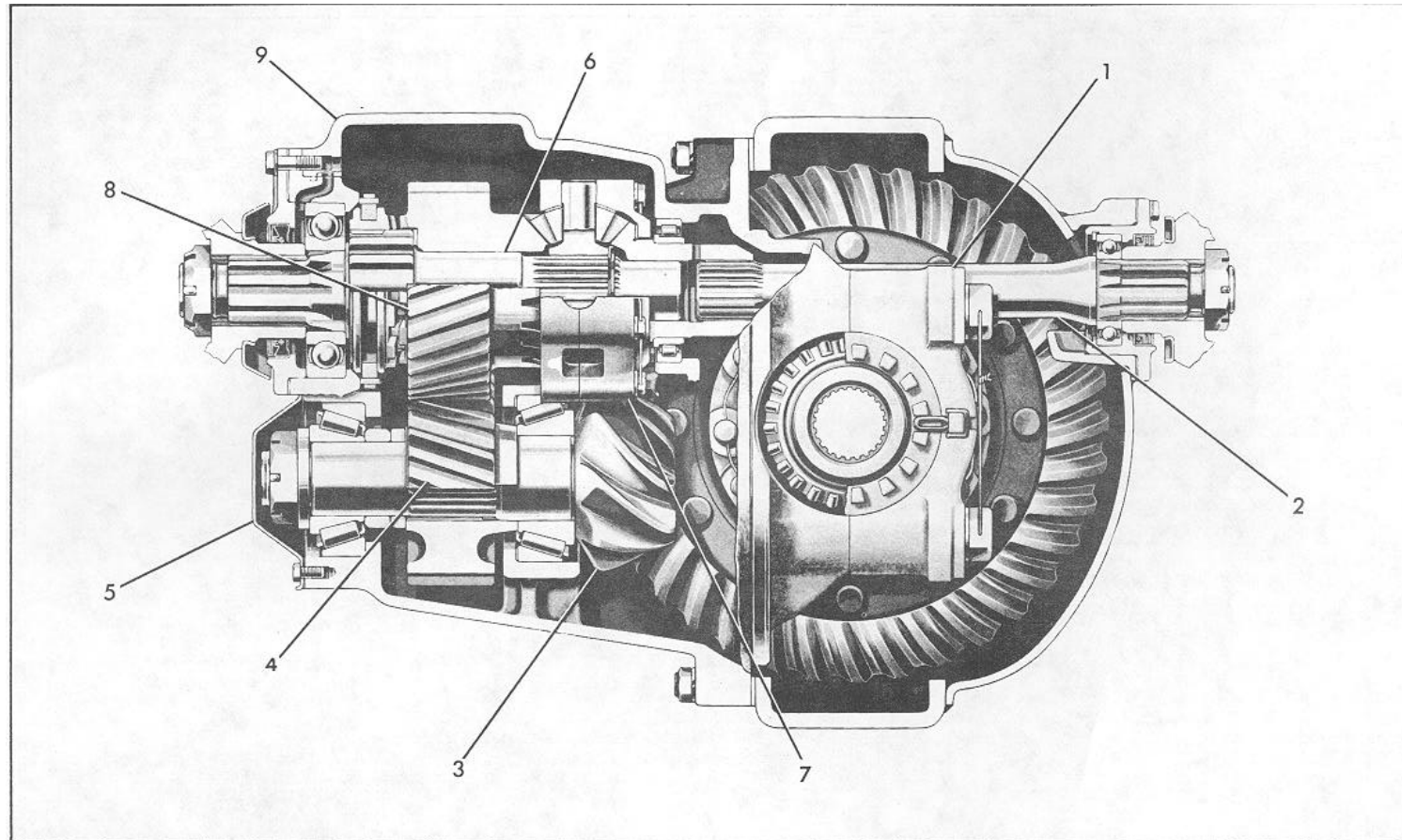

- 1 Differential Case and Gear Assembly
- 2 Thru Shaft
- 3 Diff. Drive Pinion
- 4 Drive Gear
- 5 Pinion Bearing Cover
- 6 Input Shaft
- 7 Inter-axle Diff. Case
- 8 Transfer Gear (Driven)
- 9 Housing

Illustration 4-14. Single Reduction Hypoid Drive Unit. (Sheet 2 of 3)

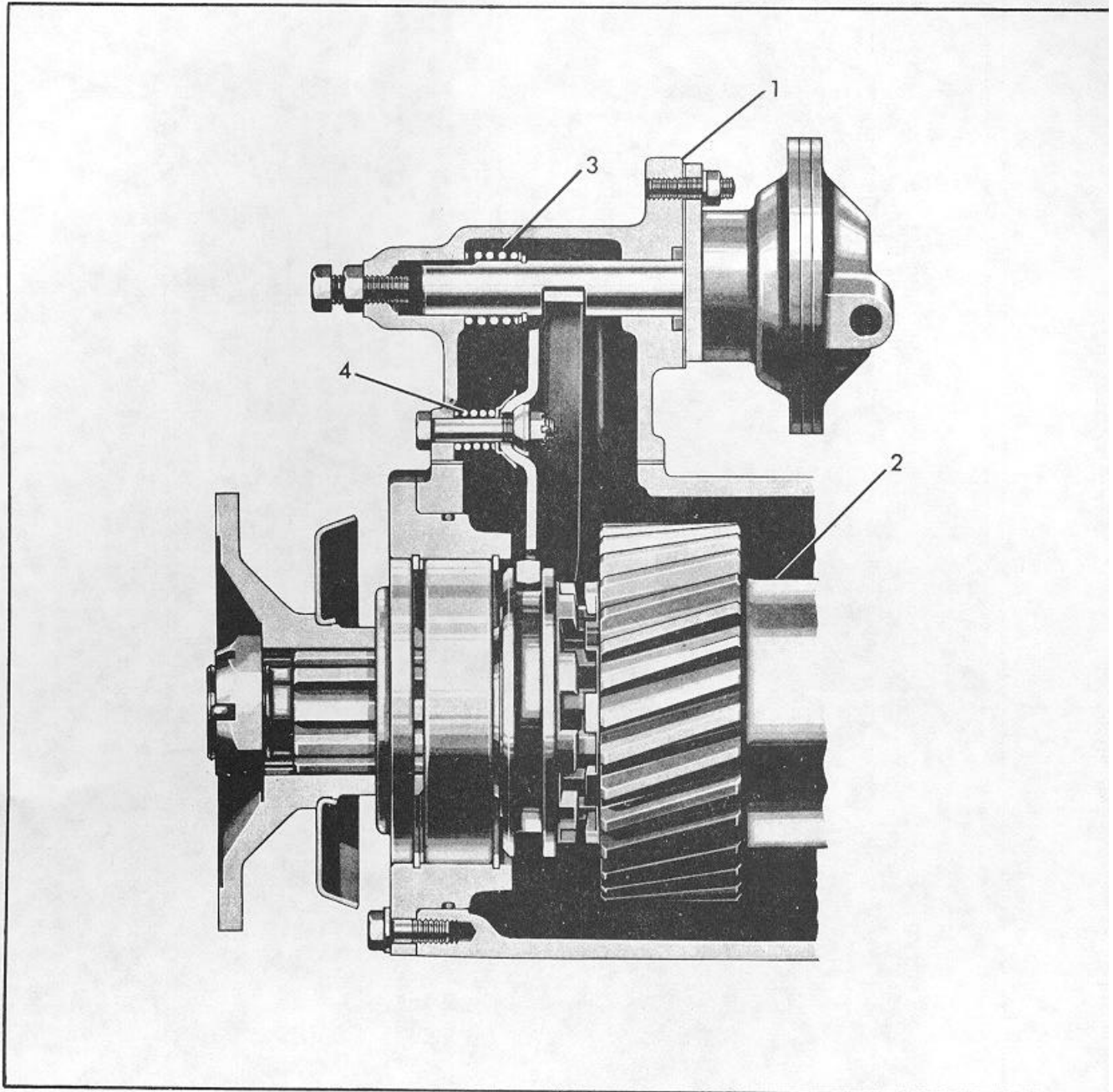

- 1. Shift Unit
- 2. Inter-Axle Differential Assembly
- 3. Spring
- 4. Spring

Illustration 4-14. Single Reduction Hypoid Drive Unit (Sheet 3 of 3)

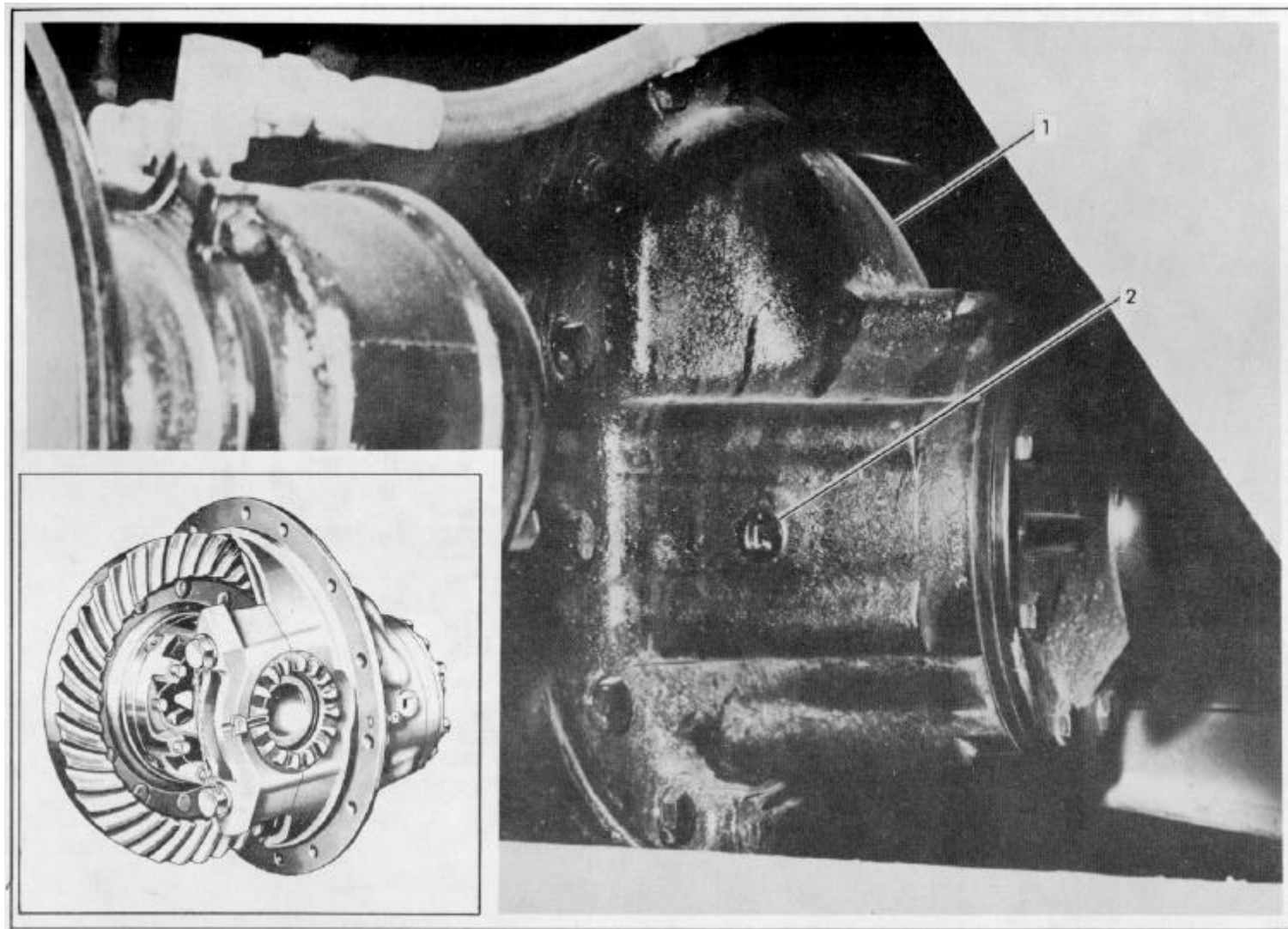

1. Single-Reduction Drive Unit
2. Lube Check Plug

Illustration 4-15. Single Reduction Drive Unit.

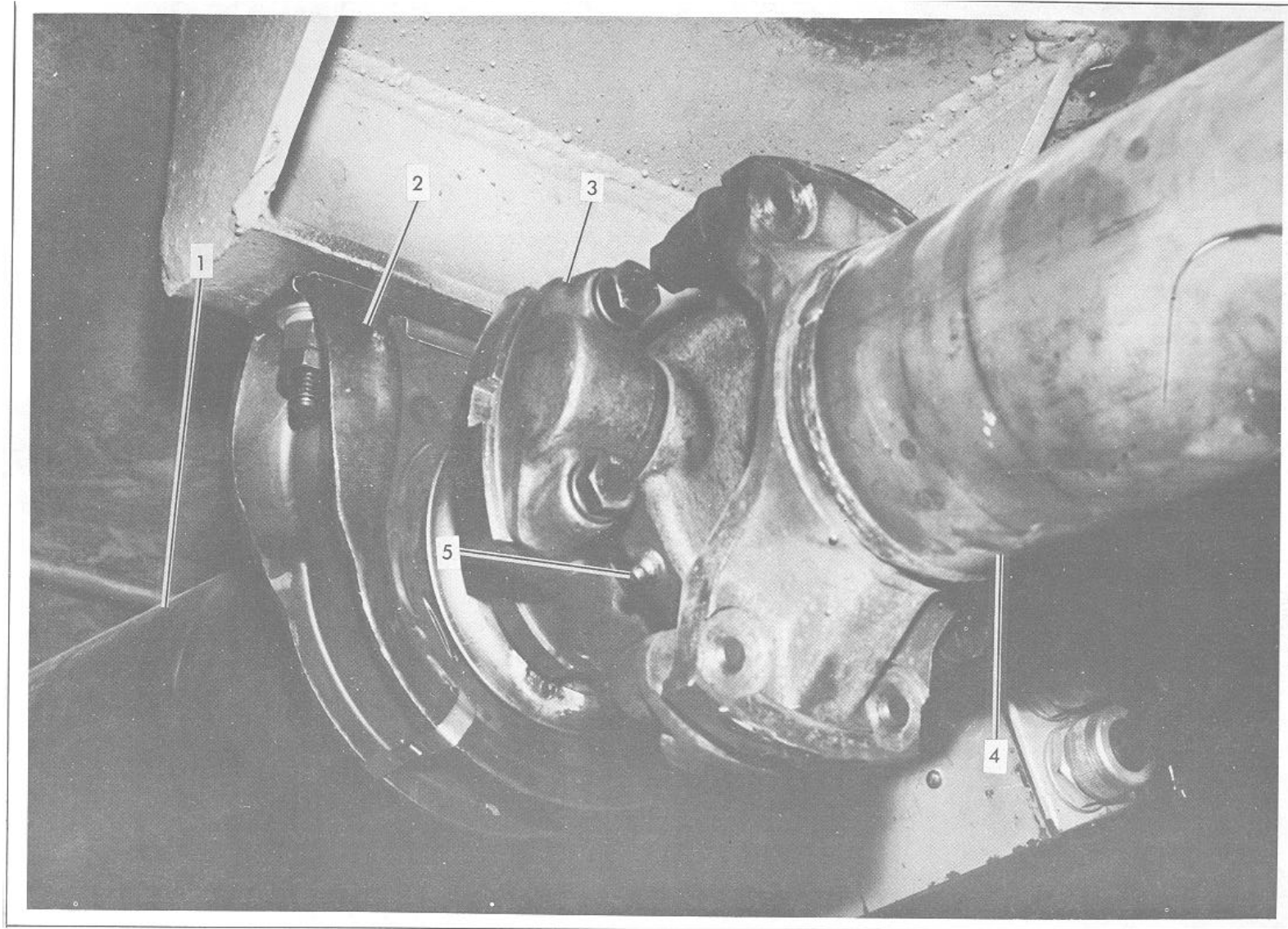

1. Propeller Shaft

2. Center Bearing

3. Journal and Bearing

4. Propeller Shaft

5. Lube Fitting

Illustration 4-16. Universal Joints and Drive Shafts. (Sheet 1 of 2)

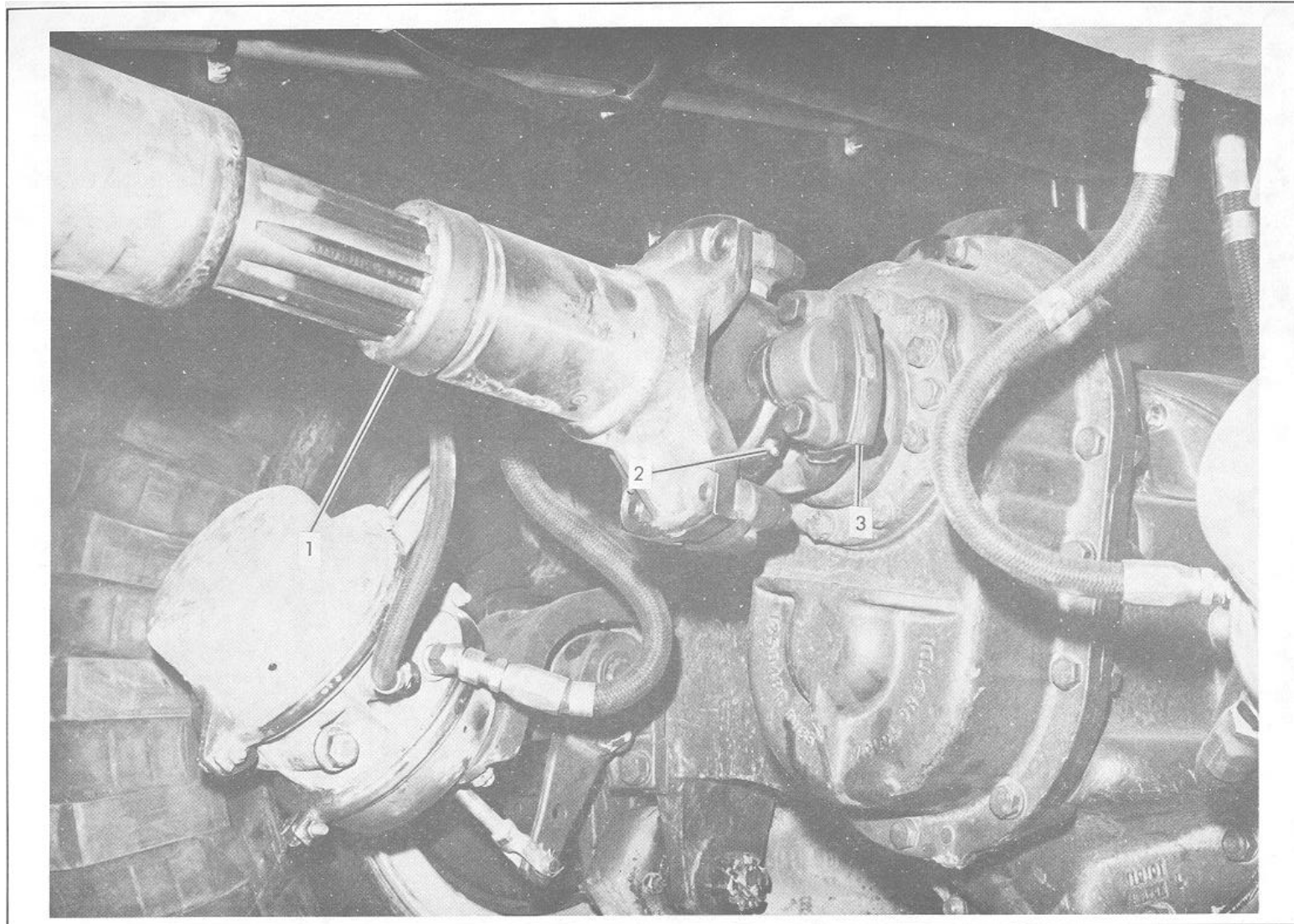

1. Propeller Shafts
2. Lube Fitting
3. Journal and Bearing

Illustration 4-16. Universal Joints and Drive Shafts (Sheet 2 of 2)

High quality anti-friction bearings are used to withstand required loads while oscillating at high speeds. These bearings on the journal cross carry very high loads for their size. The full complement, roller-type (needle) bearings are generally used because of their high capacity in a limited space. Bearings are individually sealed to provide retention of required lubricants as well as to prevent the entry of foreign material.

Air System. (Illus. 4-17).

Air for the various components of the Carrier and Superstructure is provided by the supply, front service, and rear service reservoirs. A engine driven compressor supplies the reservoirs with air. The air required for Superstructure components is transferred from the reservoirs by the pneumatic/hydraulic swivel. Air for Carrier components passes through tubing and hoses. The hoses and tubing run along the Carrier frame to the components. Listed below are the Carrier Components that are in the Air System.

Pressure Protection Valve	Air Reservoirs
Auto Drain Valve	Alcohol Evaporator
Safety Valve	Double Check Valve
Single Check Valve	Spring Brake Control Valve
Stop Light Switch	Relay Valves
Pressure Indicator	E-6 Dual Brake Valve
Compressor	Throttle Valve
Pressure Switch	

Compressor. (Illus. 4-18).

The compressor is driven by the engine and is operating continuously while the engine is running. Actual compression of air is controlled by the compressor unloading mechanism and the governor. The governor is generally mounted on the compressor and maintains the Brake System air pressure to a preset maximum and minimum pressure level.

Intake and Compression of Air (Loaded). (Illus. 4-19 A and B). During the down stroke of the piston, a slight vacuum is created between the top of the piston and the head, causing the flat circular inlet valve to move up and off its seat.

(Note the flat square discharge valve remains on its seat). Atmospheric air is drawn through the air strainer by the open inlet valve and into the cylinder.

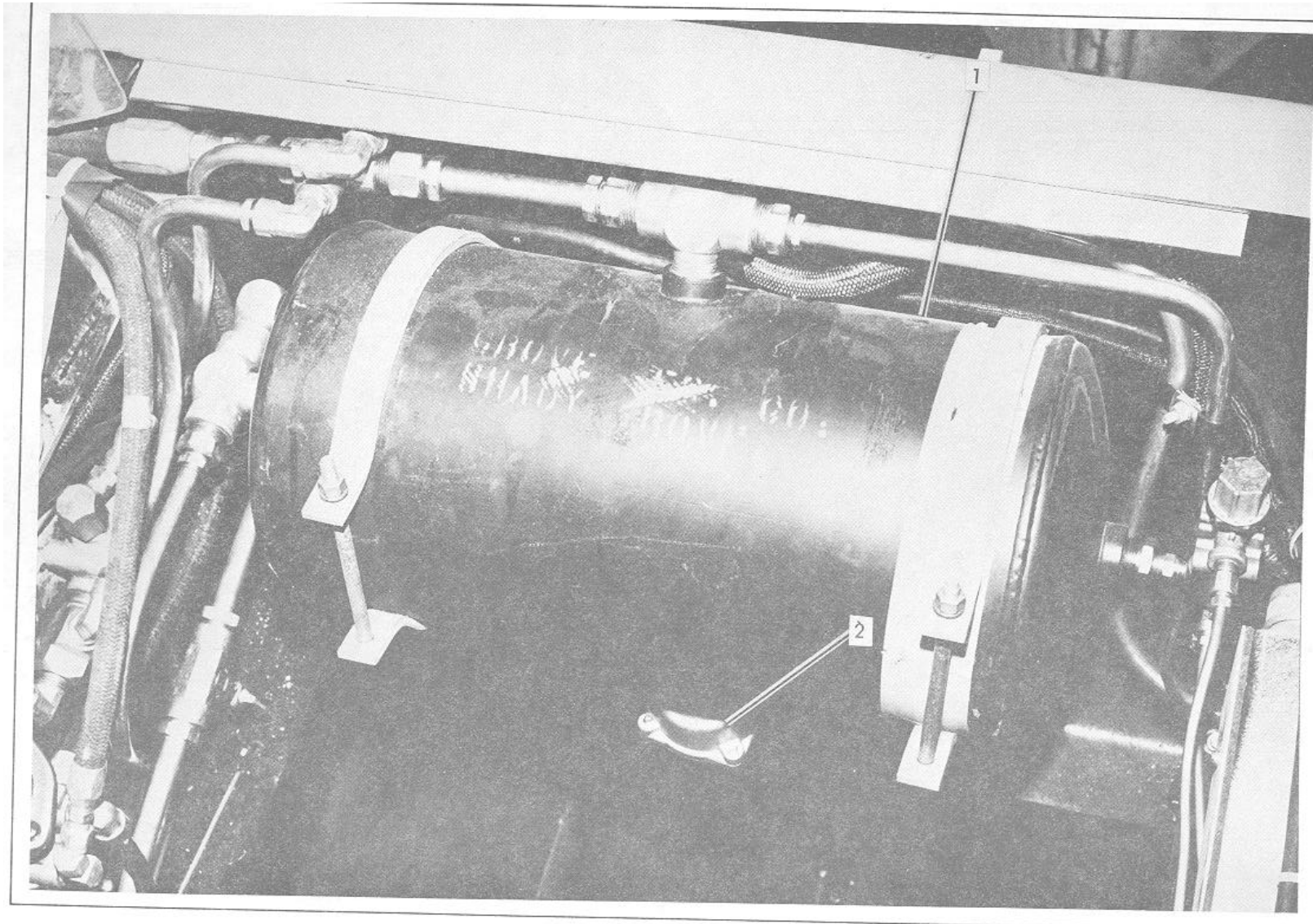

1. Air Service Tank
2. Tank Drain

Illustration 4-17. Air System. (Sheet 2 of 3)

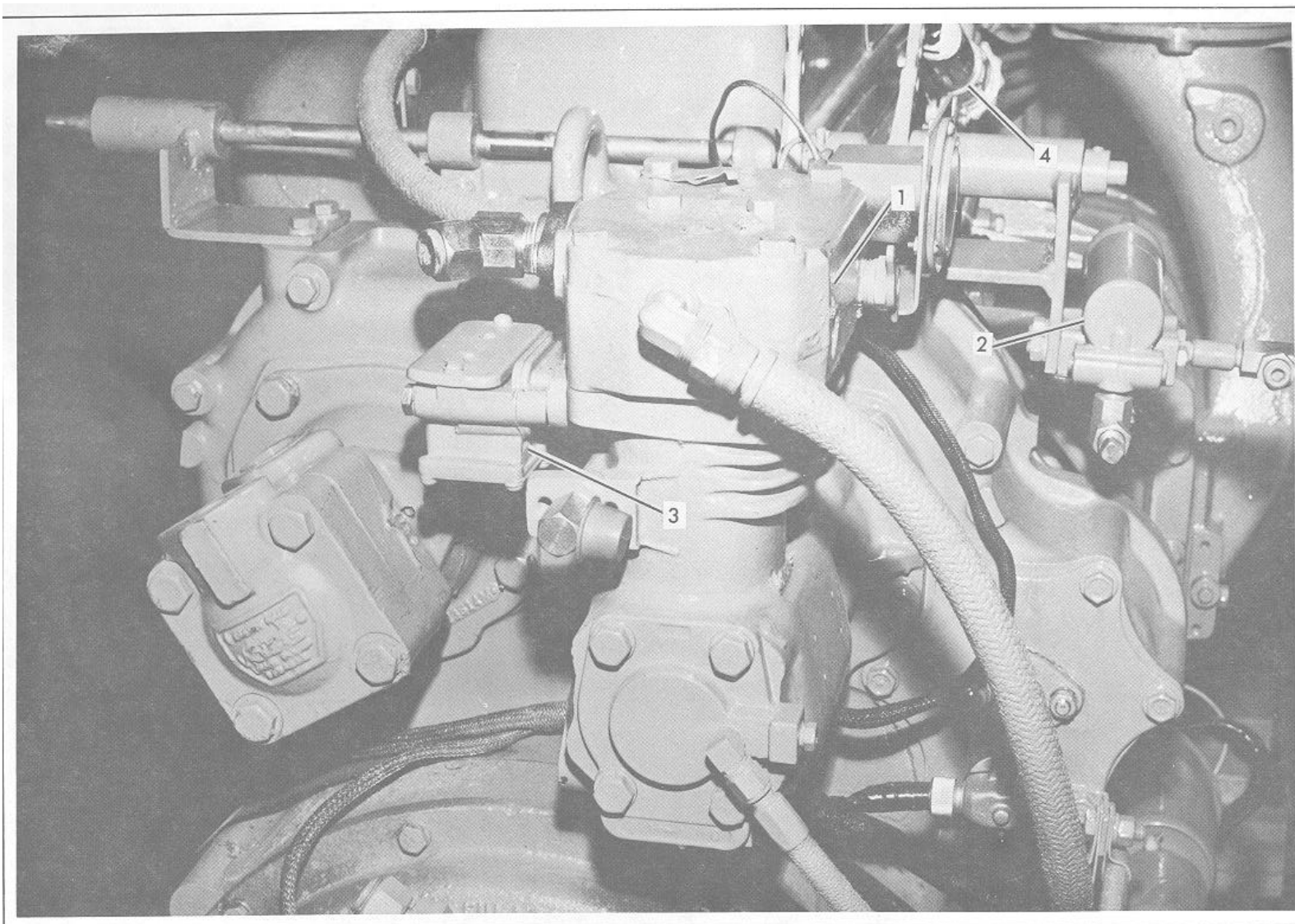

- | | |
|-------------------|--------------------------|
| 1. Air Compressor | 3. Air Compressor Filter |
| 2. Governor | 4. Throttle |

Illustration 4-17. Air System. (Sheet 3 of 3)

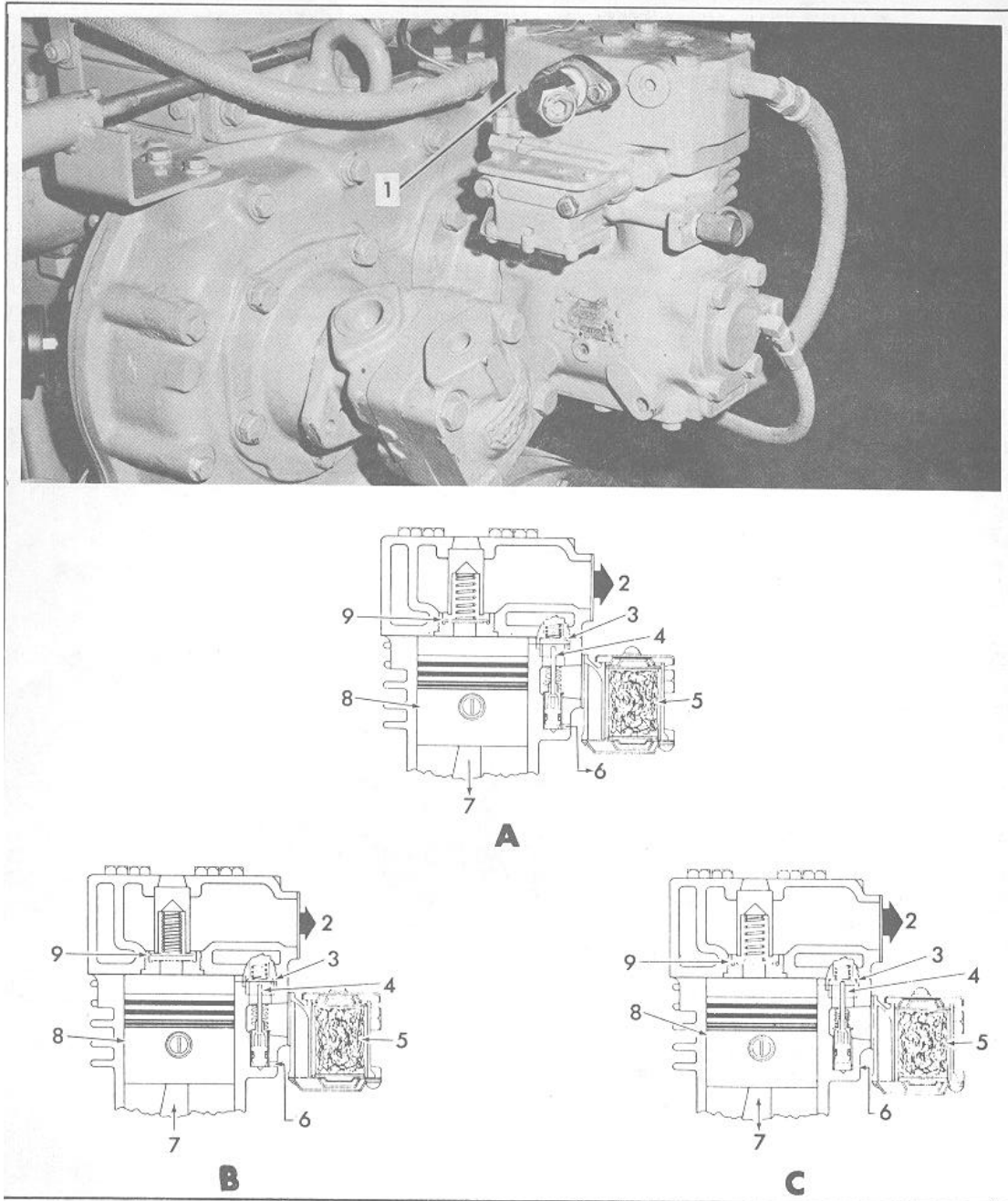

- A. Intake
 1. Air Compressor
 2. To Reservoir
 3. Inlet Valve
 4. Unloader Plunger
 5. Intake Strainer
 6. To Governor
 7. Stroke
 8. Piston
 9. Discharge Valve

- B. Compression
 1. Air Compressor
 2. To Reservoir
 3. Inlet Valve
 4. Unloader Plunger
 5. Intake Strainer
 6. To Governor
 7. Stoke
 8. Piston
 9. Discharge Valve

- C. Unloading
 1. Air Compressor
 2. To Reservoir
 3. Inlet Valve
 4. Unloader Plunger
 5. Intake Strainer
 6. To Governor
 7. Stroke
 8. Piston
 9. Discharge Valve

Illustration 4-18. Compressor.

As the piston begins its upward stroke, the air that was drawn into the cylinder on the down stroke is being compressed. Air pressure on top of the inlet valve plus the force of its spring, returns the inlet valve to its seat. The piston continues the upward stroke and compressed air then flows by the open discharge valve, into the discharge line and on to the reservoirs. As the piston reaches the top of its stroke and starts down, the discharge valve spring and air pressure in the discharge line returns the discharge valve to its seat. This prevents the compressed air in the discharge line from returning to the cylinder bore as the intake and compression cycle is repeated.

Non-Compression of Air (Unloaded). (Illus. 4-19C). When air pressure in the reservoir reaches the cut-out setting of the governor, the governor allows air to pass from the reservoir into the cavity beneath the unloader pistons. This lifts the unloader pistons and plungers. The plungers move up and hold the inlet valves off their seats.

With the inlet valves held off their seats by the unloader pistons and plungers air is pumped back and forth between the two cylinders. When air is used from the reservoir and the pressure drops to the cut-in setting of the governor, the loader saddle spring forces the saddle, pistons and plungers down and the inlet valves return to their seats. Compression is then resumed.

Brakes. (Illus. 4-19).

The brakes are mounted on the 8 wheels of the Carrier. The front brakes are 15" x 6" and the rear brakes are 15" x 7". Air to operate the brakes is provided by the engine driven compressor of the Air System. A brake pedal in the Carrier when depressed allows air flow to the brake assemblies.

The brakes used on the Carrier are wedge actuated. The brake shoes are automatically adjusted for wear. A fail safe feature is incorporated on brakes of the rear axle. When air pressure is removed from the failsafe unit a spring forces a piston against a diaphragm plate and the brakes are applied.

Brake Assembly.

The brake assemblies used are Stopmasters. The description that follows will describe an earlier model brake assembly although a later model may be found in the field. The illustrations that accompany the text will show both types. Operation of both models is the same.

Brake Assembly.

The brake assemblies used are Stopmasters. This system has an air chamber power unit threaded into the wedge bore of the plunger housing. The socket in the end of the diaphragm push rod connects the air chamber to the wedge rod. The wedge retracting spring acts as the return spring for both the wedge and the diaphragm. A pair of rollers are held in place on the wedge head by a retaining cage. The rollers are also engaged in corresponding slots in the inner ends of the plungers. The unslotted portions of the inner ends of the plungers are resting on abutments in the plunger housing. The outer ends of the plungers are engaged with and supporting the brake shoes.

The brakes are double-actuated, each of the two actuating systems has one anchor (solid) plunger and one adjustable plunger. All of the plungers are retained in the housings and the roller slots are kept in proper alignment by means of guide screws which engage slots in the side of the plungers.

When the brake is actuated, the air chamber pushes the wedge head deeper in between the rollers. This spreads the rollers and plungers apart and pushes the brake shoes outward. Initially all the plungers are lifted off of the plunger abutments and momentarily suspended. As the shoes (linings) contact the drums, the drum drags the shoes and the suspended plungers around with it. This causes the plunger at the trailing end of each shoe to reseat on its abutment and thus absorb and transfer the brake torque to the brake support. When the brake is released, the wedge spring returns the wedge and diaphragm to the off position. At the same time, the shoe return springs push the raised plungers back to their abutments.

The Fail-Safe unit is a spring powered brake actuator that assembles piggyback on the air chamber. When 70 psi or more air pressure is applied against the piston, the spring will be held in a compressed position. When the air pressure is removed, the spring will push the piston against the diaphragm plate and apply the brake.

The plungers are adjusted automatically. The adjusting bolt is threaded into an adjusting sleeve which in turn is free-fitted inside the plunger proper. The plunger guide screw is replaced by a hollow cap screw, a spring, and an adjusting pawl which also serves as the plunger guide. The end of the adjusting pawl has saw-tooth type teeth which engage corresponding helical teeth on the outside of the adjusting sleeve.

As the brake is actuated; the plunger, sleeve, and bolt move outward and the sloping face of the teeth on the adjusting sleeve lifts the adjusting pawl (against the spring). When the brake is released, all the parts return to their starting points. As the lining wears, the plunger stroke and resulting pawl lift gradually increases until the pawl climbs over and drops into the next tooth space. This time, when the brake is released and the plunger is pushed back in its bore, the upright face of the pawl teeth causes the adjusting sleeve to rotate and advance the adjusting bolt. This reduces the lining clearance and the cycle starts over again. The automatic adjuster operates only in forward vehicle direction.

On double-actuated brakes, the anchor (solid) plungers should be positioned at the trailing end of each shoe (where they will absorb the brake torque during forward wheel rotation). This will position the adjustable plungers at the leading end of the shoes. Also note that the shoe web is unsymmetrical. The long-radius end should be engaged with the adjustable plungers.

The air chamber should be screwed into the wedge bore of the plunger housing to a depth such that the wedge is ready to lift the plungers off of the abutment seats at the first movement of the diaphragm (or piston). This provides the least lost motion and maximum useful chamber (or piston) stroke.

This unit is designed to "bottom-out" in the wedge bore and provide this optimum adjustment automatically.

Whenever the power unit is removed from the brake, the wedge assembly may also become dislodged. Before reinstalling the power unit, reposition the wedge assembly so that the rollers and roller cage are engaged in the plunger slots. This is accomplished automatically by simply aligning the two ears on wedge spring retainer with corresponding grooves in the wedge bore of the plunger housing.

All Fail-Safe units are equipped with manual caging bolts to permit safe handling for service work. These bolts are sealed and prevented from rotating due to vibration.

WARNING

When the brakes are equipped with Fail-Safe units, cage the power springs before starting any disassembly or removal of wheels and drums. After parts are all reassembled and in place, uncage the power springs before returning the vehicle to service.

When a vehicle is disabled due to low or lost air pressure, block wheels and cage the power springs before moving the vehicle.

Manually Caging and Uncaging Fail-Safe Units: On the standard Fail-Safe, first loosen the boot clamp screw and remove the rubber boot (if one is used). Then loosen the caging bolt-lock screws and swing the lock out of the way.

The power spring is manually caged (compressed) by turning the caging bolt clockwise approximately 18 to 21 full turns. Do not force the bolt beyond its normal stop. Uncaging (releasing) the spring is accomplished by reversing the procedure again do not force the bolt beyond its normal stop. If desired, both the manual caging and uncaging operation can be made easier by applying air pressure to the Fail-Safe chamber to take the spring load off the caging bolt. Fail-Safe Units can also be caged by air using the vehicle emergency air system or other available air supply. Apply and hold 70 psi air pressure through the parking port of the Fail-Safe Unit to hold the power spring compressed.

On standard Fail-Safe units, after manually uncaging the spring, swing boltlock back and secure in place. Clean cap and boot and install boot with vent slot at bottom.

This system (shown in the off position) has an air chamber power unit threaded into the wedge bore of the plunger housing. The socket in the end of the diaphragm push rod connects the air chamber to the wedge rod. The wedge retracting spring acts as the return spring for both the wedge and the diaphragm. A pair of rollers are held in corresponding slots in the inner ends of the plungers. The unslotted portions of the inner ends of the plungers are resting on abutments in the plunger housing. The outer ends of the plungers are engaged with and supporting the brake shoes.

On a double-actuated brake, each of the two actuating systems has one anchor (solid) plunger and one adjustable plunger. On a single actuated brake the one actuating system would have two adjustable plungers. All of the plungers are retained in the housings and the roller slots are kept in proper alignment by means of guide screws which engage slots in the side of the plungers. A hydraulic brake would have a hydraulic cylinder threaded into the plunger housing (in place of the air chamber). The hydraulic piston would connect with the wedge rod.

When the brake is actuated, the air chamber pushes the wedge head deeper in between the rollers. This spreads the rollers and plungers apart and pushes the brake shoes outward. Initially all the plungers are lifted off of the plunger abutments and momentarily suspended. As the shoes (linings) contact the drums, the drum drags the shoes and the suspended plungers around with it. This causes the plunger at the trailing end of each shoe to reseat on its abutment and thus absorb and transfer the brake torque to the brake support. When the brake is released, the wedge spring returns the wedge and diaphragm to the off position. At the same time, the shoe return springs push the raised plungers back to their abutments.

The Fail-Safe unit is a spring powered brake actuator that assembles piggy-back on the air chamber. When 70 psi or more air pressure is applied against the piston, the spring will be held in a compressed position. When the air pressure is removed, the spring will push the piston against the diaphragm plate and apply the brake.

The Stopmaster II Wedge brake now incorporates a series of design changes based on the original Stopmaster brake.

Major design improvements have been made in four general areas of the brake: (1) The automatic adjusting assembly; (2) The adjusting pawl assembly; (3) The non-pressure half of the air chamber; and (4) The brake shoe and drum.

The automatic adjusting assembly for the Stopmaster II employs a limited travel adjusting bolt which cannot over adjust or cock when the brake lining has been extremely worn.

This is accomplished with the addition of a snap ring at the foot of the bolt and a redesigned adjusting sleeve (actuator) and plunger.

The adjusting sleeve has been counterbored on the I.D. to accept the redesigned adjusting bolt. Thus, when the lining is worn, the counterbored shoulder of the adjusting sleeve stops the bolt from advancing further. Consequently, the bolt is prevented from over adjusting.

To accommodate these changes, the I.D. of the adjusting plunger has also been counterbored to make room for the snap ring.

If the original adjusting sleeve (actuator) which does not have the new counterbore (has internal threads the full length) is to be used, do not employ the adjusting bolt retainer (snap) ring. Use of the retainer (snap) ring with the old style adjusting sleeve (actuator) and new style adjusting bolt would prevent the adjusting bolt from moving outward and making the necessary lining wear adjustment.

In addition, the adjusting bolt now has a machined smooth wiping surface under the head to accept a new single lip plunger seal.

This seal is designed to allow more flexibility and will provide additional protection for the adjusting assembly when the bolt is extended outward in brake application. Thus, this will reduce the possibility of the adjusting bolt freezing, due to any corrosion or dirt inside the actuation housing.

The adjusting assembly also employs a new single lip plunger seal to provide more protection for the bolt threads and improved sealing for the actuation housing components. The lip of this seal wipes against the smooth machined surface beneath the head of the bolt.

To protect the plunger seal, the head of the adjusting bolt incorporates a redesigned stamped seal protector and rolled spring lips. The seal protector is angled downward to act as a shield over the plunger seal. This prevents contact between the seal and the adjusting spoon when the brake is being adjusted manually. The spring lip serves to protect the plunger seal when the bolt is in the bottomed position.

To further facilitate the initial manual adjustment, the star wheel portion of the adjusting bolt head employs square teeth.

The adjusting pawl for the Stopmaster II Wedge brake employs an integral key which mates with a slot in the adjusting pawl guide hole of the redesigned brake spider of actuation housing.

The power unit of the Stopmaster II employs a larger, and more flexible diaphragm boot seal. It also employs a boot retainer clamp which is riveted to the wall of the non-pressure half of the housing. The lip of the diaphragm boot is positioned beneath the boot retainer clamp, and is thus held tightly against the wall of the non-pressure housing. This provides improved sealing for the air chamber tube by preventing road contaminants from entering the wedge area and contaminating the lubricant. Further, the mechanical attachment of the boot retainer clamp prevents possible separation of the diaphragm boot from the housing.

Other design improvements for the Stopmaster II include a chamfer on the brake drum on the inside outer edge to facilitate removal when brake service is necessary. The chamfer allows the brake lining to overlap the drum edge by approximately 1/16". This, in turn, prevents the development of scored wear rings on I.D. of the drum, which could interfere with disassembly.

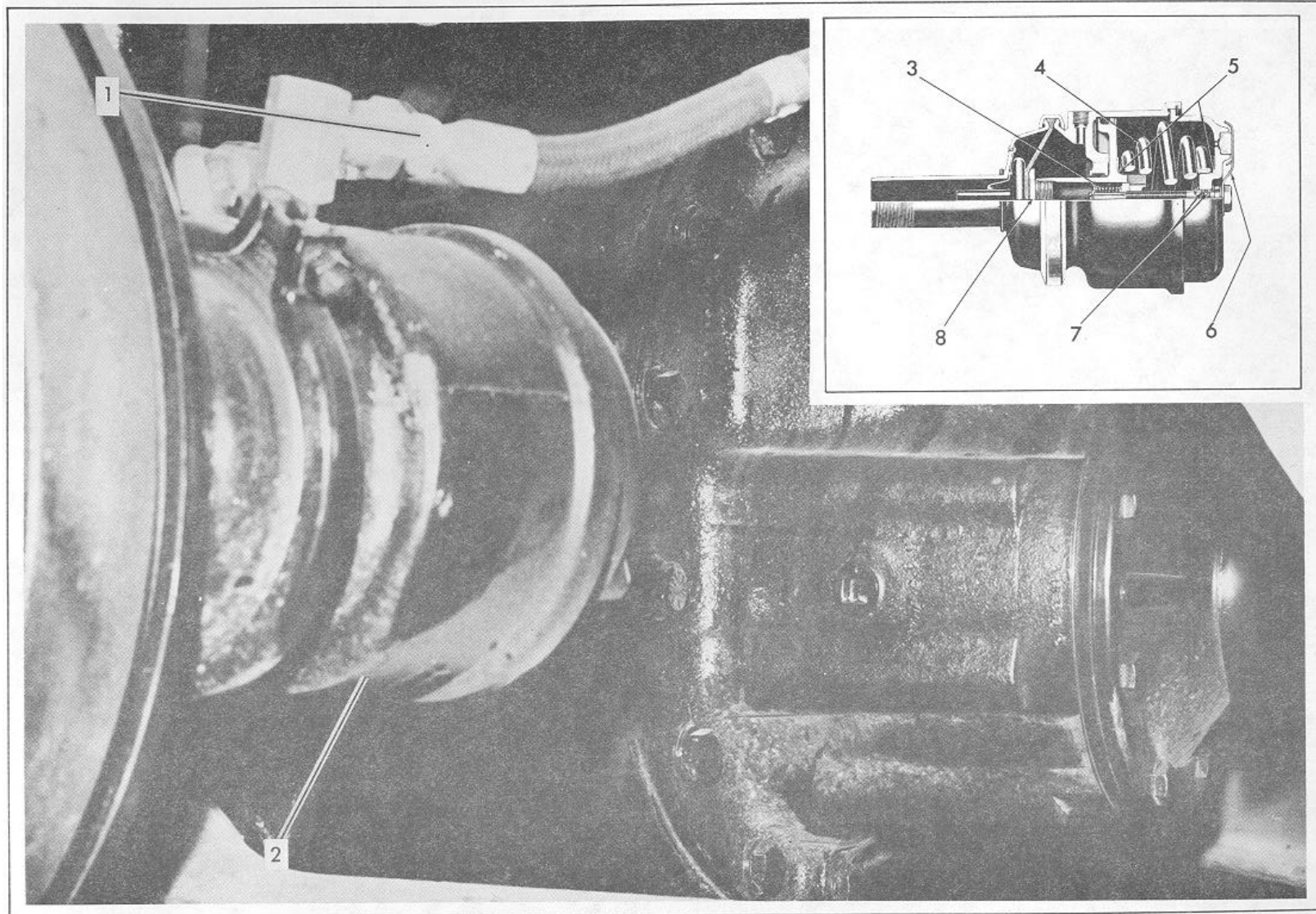

- 1. Air hose
- 2. Emergency and Parking Brake Power Unit (Fail Safe)

- 3. Nut Preload Spring
- 4. Vinyl Coated Spring

- 5. Cap and Piston
- 6. Retainer Spring Lock

- 7. Double Seal
- 8. Float

Illustration 4-19. Brakes. (Sheet 1 of 2)

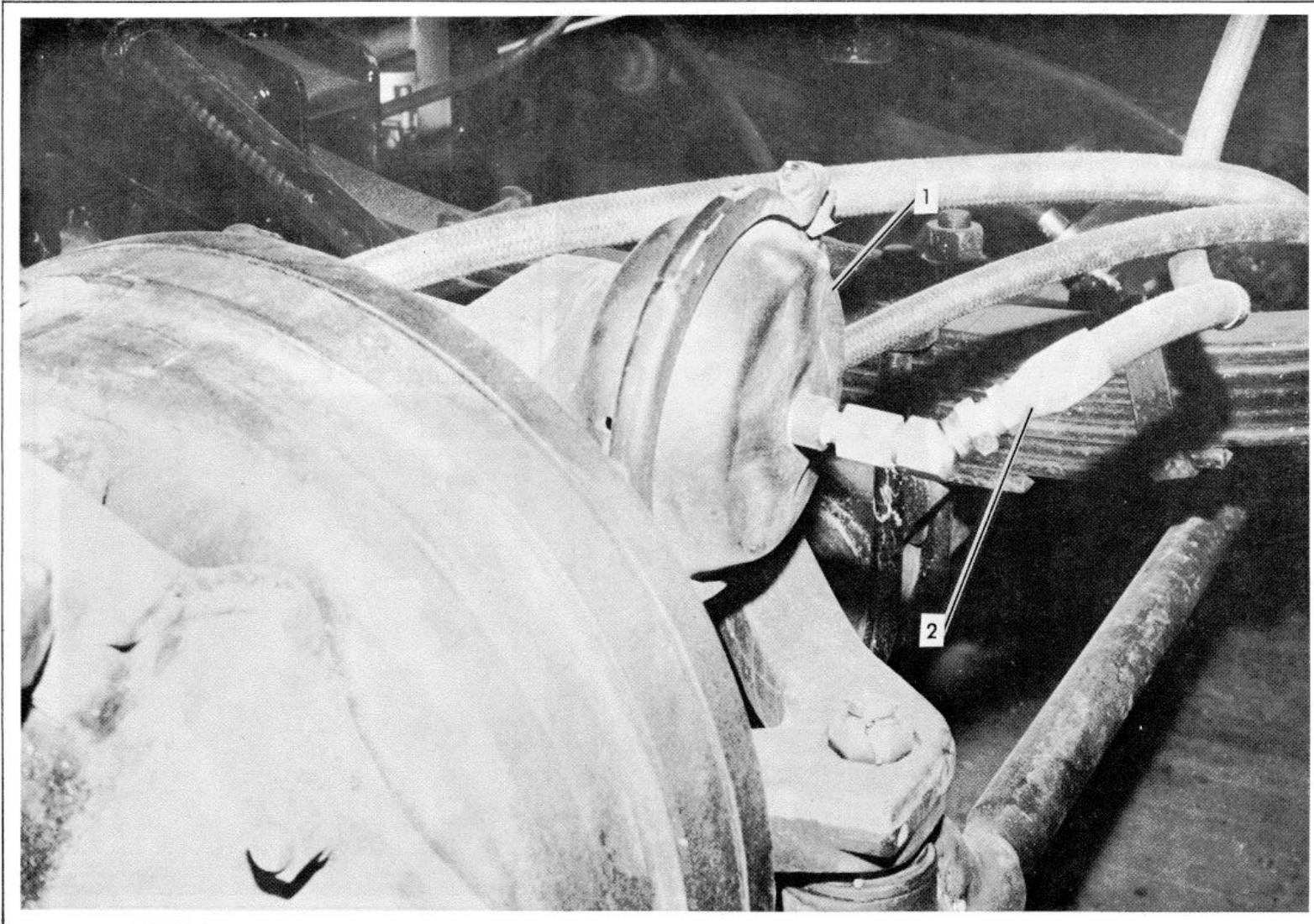

- 1. Air Chamber
- 2. Air Hose

Illustration 4-19. Brakes. (Sheet 2 of 2)

The Super "B" Fail-Safe II is an emergency and parking brake power unit designed to be used with Stopmaster wedge brakes. This Fail-Safe unit also incorporates a series of changes (based on the original Super Fail-Safe unit) that will provide improved service life and simplified maintenance. These improvements have been made to six components: The nut pre-load spring; a redesigned foot; the cap and piston radii; the retainer spring lock; the double seal construction, and; a vinyl coating on the power spring.

The caging bolt employs a double seal construction beneath the head of the bolt for improved sealing. This keeps road contaminants from entering the Fail-Safe unit and corroding the inside of the chamber. Further, this double bolt seal design also provides more support and better alignment for the caging bolt assembly.

The caging bolt and nut assembly employs a nut preload spring to replace the original hex nut. This preload spring applies continuous pressure against the caging (square) nut, holding the nut adjacent to the last thread of the bolt. The assurance of thread engagement, provided by this caging bolt design facilitates caging the Fail-Safe unit when brake service is necessary.

The piston foot incorporates a machined bore to accommodate the caging bolt and nut preload spring assembly. It also employs an "O" ring for added sealing. Further, the foot and seal assembly is threaded into the piston, and held securely in place with the use of Loctite sealant. This eliminates the need for a set screw.

Electric System. (Illus. 4-20 and 4-21).

Electric power for the Superstructure and Carrier components is supplied by a 60 AMP engine driven alternator. Electric power for operation of lighting and certain accessory components is provided by one of the 12 volt batteries. Power for engine starting is provided by four 12 volt batteries connected in series/parallel. The Electric System has a alternator safety switch. The switch prevents the alternator from coming on the line until the oil pressure reaches a predetermined pressure.

Heaters.

The carrier cab is supplied with a hot water circulation type heater.

Hot water for the circulation heater is taken from the engine Coolant System. The water is carried by hoses to cores. When heat is desired in the cab, the shut off valve is opened. With the shut off valve opened hot water flows to the cores. A switch located in the cab controls operation of the fan that blows the hot air exhausted from the core into the cab.

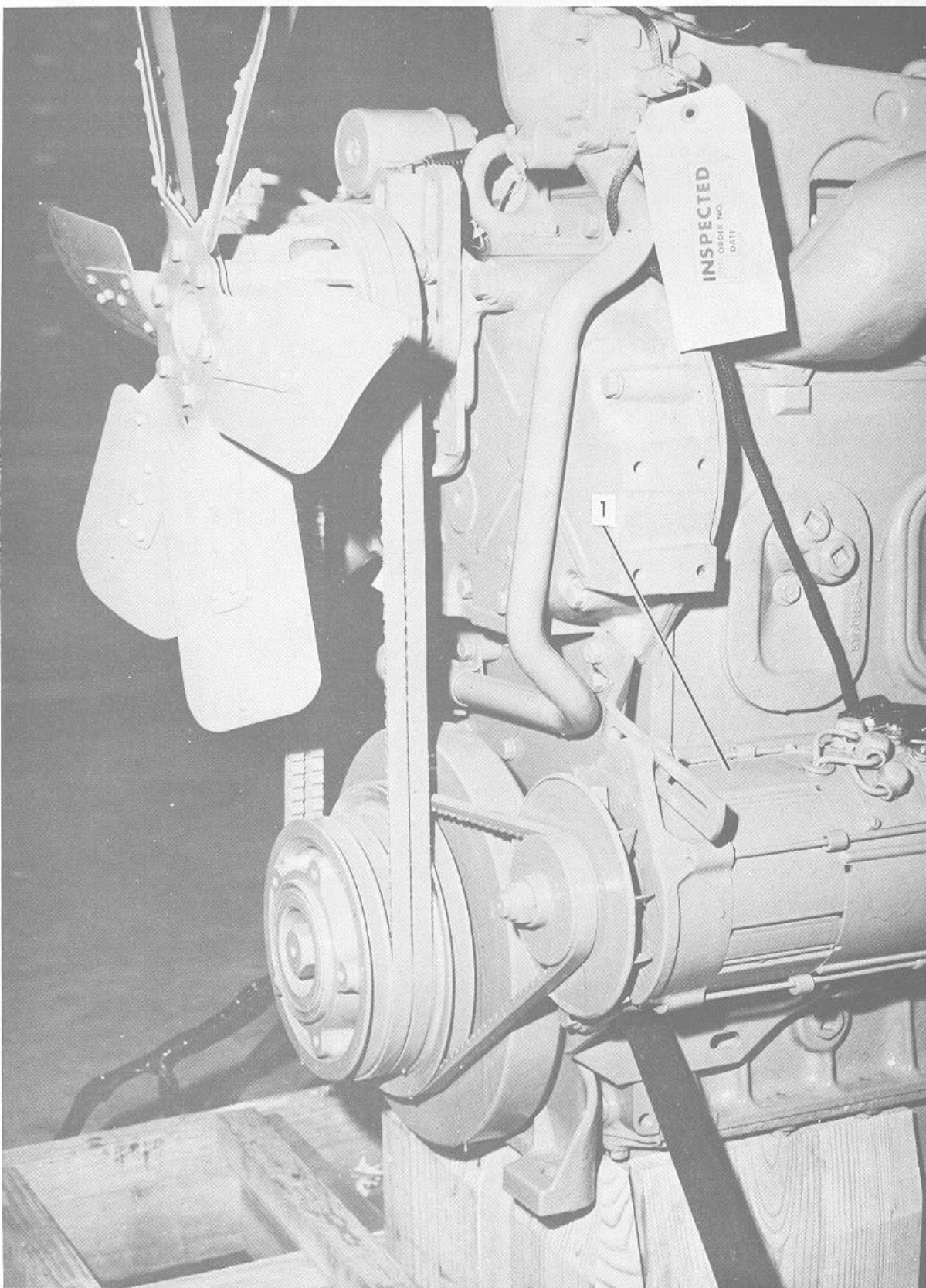

1. Alternator

Illustration 4-20. Electric System. (Sheet 1 of 3)

Alcohol Evaporation System. (Illus. 4-22).

When the Compressor is in the compression cycle, a partial vacuum is present at the Compressor Intake. Tubing from the Alcohol Evaporator is connected to the Compressor Intake, therefore a partial vacuum is also created above the alcohol in the Alcohol Reservoir. Air (atmospheric pressure or greater depending on type of installation) enter the Alcohol Evaporator, passes through the tube which is immersed in the alcohol. The passing of air through the alcohol allows the alcohol to bubble, and the vapor formed by the bubbling is induced into the Compressor intake and into the air brake system.

Quick Start System

The Quick Start System has an atomizer, valve assembly and ether bottle. The Quick Start System is usually used during cold weather operations to facilitate engine starting. To operate the system, the starter switch must be in the start position before the quick start button is depressed. With the starter switch in the start position, and button depressed, the valve assembly is actuated open.

Ether flows from the bottle, and is squirted into the intake manifold.

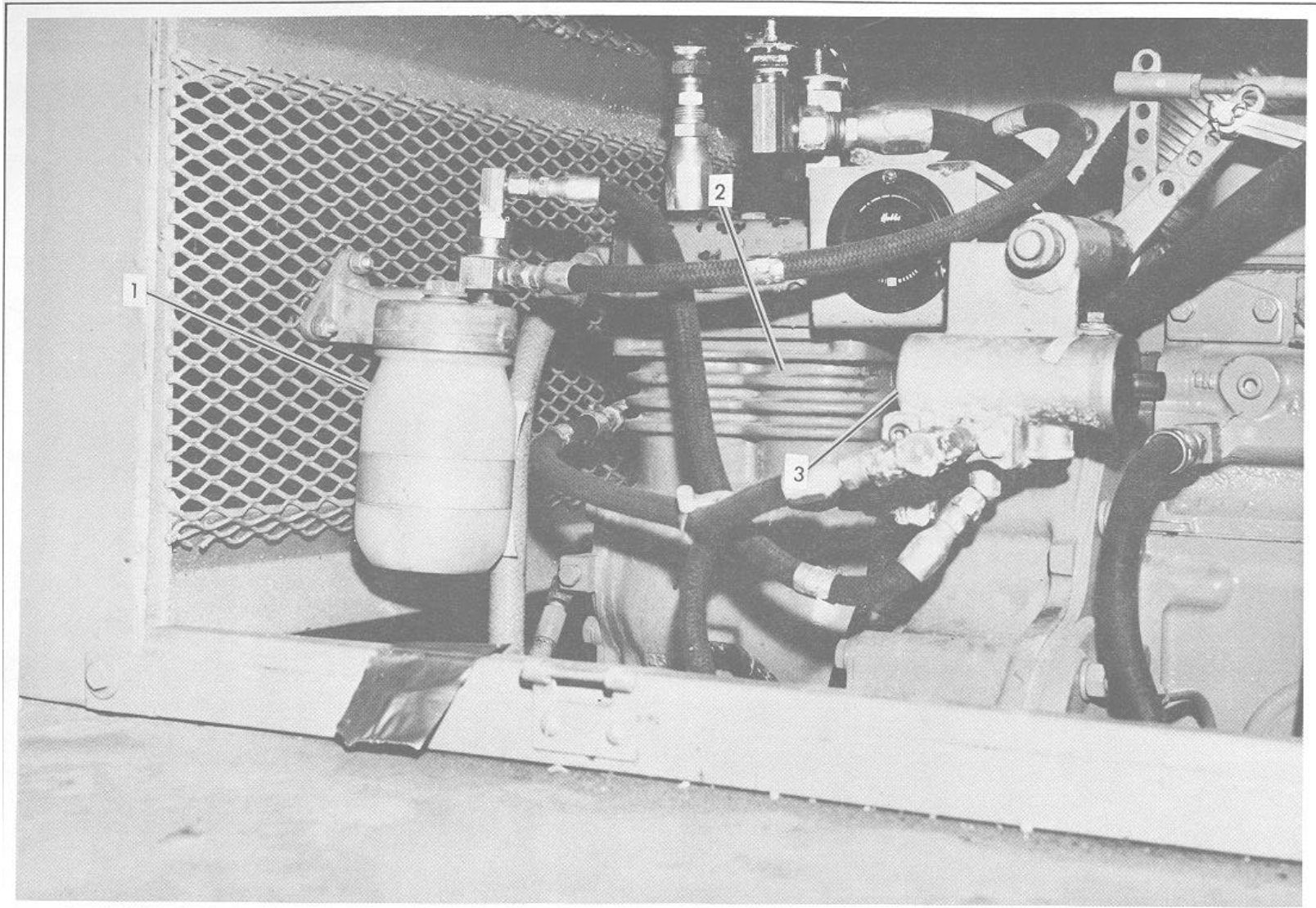

1. Alcohol Bottle
2. Air Compressor
3. Governor

Illustration 4-22. Alcohol Evaporation System.

MAINTENANCE.

The instructions given in the following paragraphs provide service personnel with removal, disassembly, inspection, testing, reassembly and troubleshooting procedures for major Carrier components. Refer to the applicable Engine Manual for engine maintenance procedures.

ENGINE AIR SYSTEM.

Air Filter.

DISASSEMBLY. (Illus. 4-23).

It is recommended that the body and fixed element in the heavy-duty type air cleaner be serviced every 500 hours of operation or as conditions justify.

The frequency of servicing may be varied to suit local dust conditions.

WARNING
NEVER SERVICE AIR CLEANER WHILE ENGINE IS RUNNING.

1. Loosen thumbscrew on clamp band (2). Remove vacuator valve (1).
2. Remove end cover (5), dust cup (7), and baffle (4).
3. Remove thumbscrew (3), washer (9) and withdraw element (8).
4. Replace element after ten cleanings.
5. Inspect all parts of the intake system and air cleaner.
6. Install cleaned or new element in air cleaner body; secure with thumbscrew (3) and washer (9).
7. Install baffle (4) with slot at top. Install dust cup(7) with arrow on bottom of cup pointing straight up.
8. Install top cover (5) and vacuator valve (1). Tighten clamp band (2) securely.

CLEANING.

Washing in water-detergent solution and blowing out with compressed air are two accepted methods for cleaning the main elements of the air cleaner. If elements contain substantial amounts of soot or oil fumes, washing in water works better than compressed air. If the contaminant is found to be mostly loose dust, either method works equally well. If cleaned with compressed air, elements can be put back into service immediately; if cleaned by washing, elements must be dried before returning them to service.

NOTE

SOME ELEMENTS ARE PARTIALLY COVERED BY A PLASTIC SLEEVE WITH FINS. THE COVERED PORTION CAN BE CLEANED WITH WATER OR AIR WITHOUT REMOVING THE SLEEVE. USE A STIFF FIBER (NOT WIRE) BRUSH TO REMOVE OIL AND GREASE DEPOSITS FROM THE SLEEVE AND FINS. NEVER REMOVE SLEEVE AND FINS FROM THE ELEMENT.

CLEANING WITH COMPRESSED AIR.

1. Direct a jet of clean, dry air from the inside of the filter element, perpendicular to the pleats. Pressure at air nozzle must not exceed 100 psi.
2. Move the air jet up and down along the pleats, slowly rotating the element, until no more dust is being removed. Be certain that the element is not ruptured by the nozzle or the air jet.

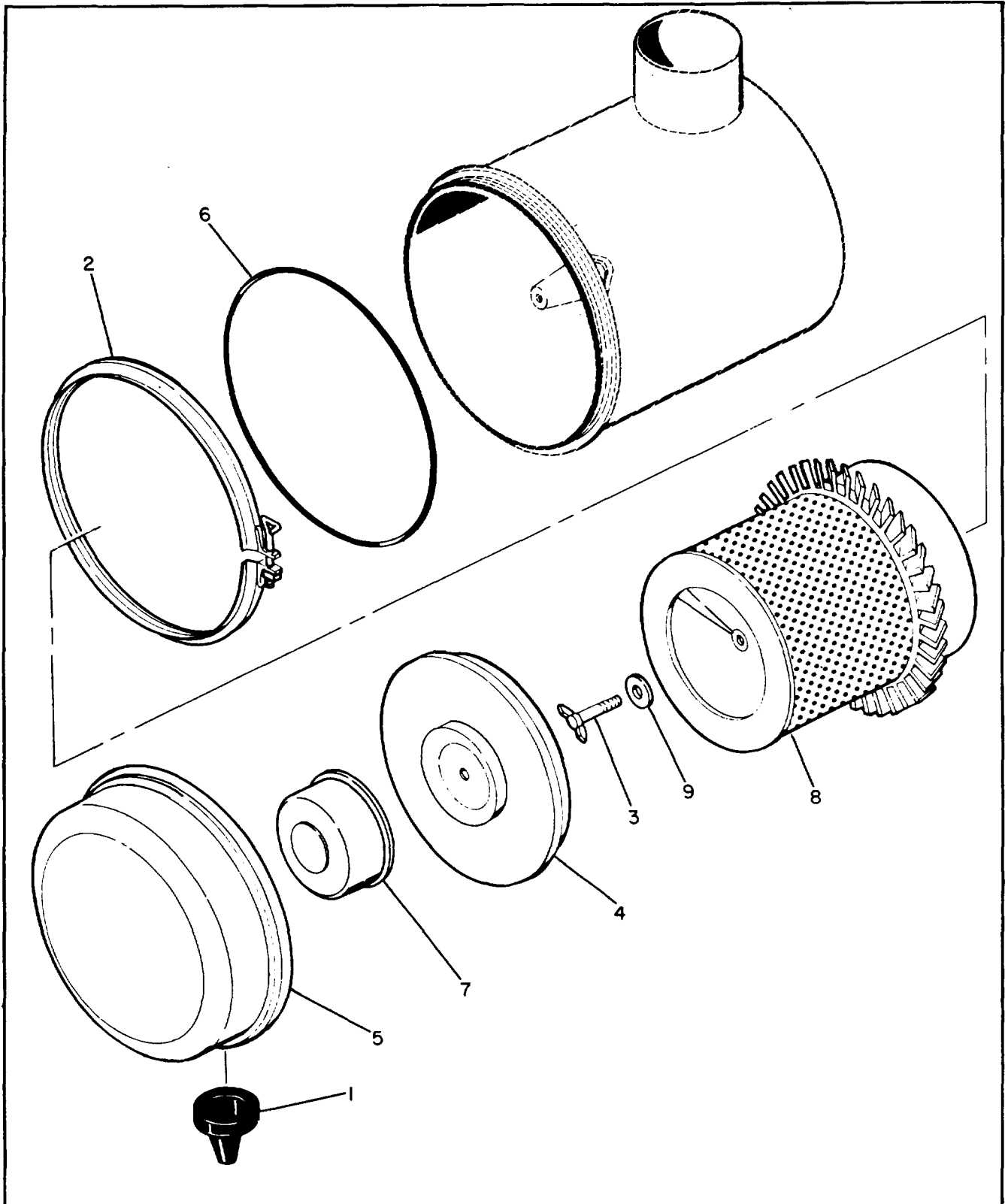

- | | | |
|---------------------|--------------|-------------|
| 1. Vacuumator Valve | 4. Baffle | 7. Dust Cup |
| 2. Clamp Bond | 5. End Cover | 8. Element |
| 3. Screw | 6. O Ring | 9. Washer |

Illustration 4-23. Air Filter

CLEANING WITH WATER.

The elements can be cleaned by washing with water and a good non-sudsing detergent. Direct a jet of clean, dry air from the inside of the filter element. When the loose dust and soot have been removed, the element is ready to be washed.

NOTE**NEVER USE GASOLINE OR SOLVENTS TO CLEAN ELEMENTS.**

1. Dissolve the detergent in a small amount of cool water.
2. Add warm (approximately 100 degrees F) water to get the proper proportions of detergent and water (about one cup of detergent to five gallons of water).
3. Soak the element in the solution for at least 15 minutes.
4. Agitate the element for about two minutes to loosen the dirt.
5. Rinse the element with clean water until the water coming through the element is clean. Water pressure from a hose or tap should not be over 40 psi. Air-dry the element thoroughly before using.
6. Mechanized drying methods can be used. However, heated air (maximum temperature 180 degrees F) must have some circulation. Do not use light bulbs for drying elements.

INSPECTION.

After cleaning the filter element; inspect the element for damage. Look for dust on the clean air side, the slightest rupture, or damaged gasket. A good method to detect ruptures in the element is to place a light inside the element and look toward the light from the outside. Any hole in the element, even the smallest will pass dust to the engine and cause unnecessary wear.

Before installing the filter element, remove any foreign material (leaves, lint, or other foreign matter) that may have collected inside the air cleaner body. Inspect the inside of the body for dents or other damage that would interfere with air flow or with the fins on the element or inside the body. Repair body dents, being careful not to damage sealing surfaces.

Vacuator valves are designed to expel loose dust and dirt accumulations from the air cleaner body automatically thus lengthening the element service life. The valve lip must point straight down to operate effectively, and must be kept free from debris. Mud and chaff can lodge in these lips periodically and hold them open during engine operation. Check condition of valve and lips frequently and keep them clean. The valve lips should be open only when the engine is shut down, or running at low idle speed. If the valve is turned inside out, check for a clogged air cleaner inlet. Malfunction of this valve does not reduce air cleaner effectiveness, but does allow the element to get dirty faster and reduces serviceable life. If a valve is lost or damaged replace it with a new valve of the same number.

Ducts.

INSPECTION.

1. Check intake pipe cap and screen for accumulation of leaves, trash, and other

- debris that could restrict air flow. Repair screen or replace cap if any large holes are found in screen.
2. Check all mounting hardware for security to eliminate possible vibration of intake piping. Such vibration leads to early failure of hoses, clamps, and mounting parts, and can cause hoses to slip off the connecting pipes, allowing unfiltered air into the engine air intake.
 3. Check hoses for cracks, chafing or deterioration, and replace at the first sign of probable failure.

TROUBLESHOOTING.

Dust passing the air cleaner, even through small holes, can cause rapid engine wear. Make sure all connections between the air cleaner and the engine are tight and seal positively. If these connections are all well sealed, and there is still evidence of dust leakage, check the following places for possible trouble.

NOTE

DUST THAT GETS BY THE AIR CLEANER SYSTEM CAN OFTEN BE DETECTED BY LOOKING FOR DUST STREAKS IN THE AIR TRANSFER TUBING OR JUST INSIDE THE INTAKE MANIFOLD INLET.

1. Inspect air cleaner outlet tube for damage.
2. Make sure the element gasket washer is not damaged, and that the washer's rubber face seals against the element.
3. Inspect the element gasket for damage.
4. Inspect the restriction tap for leaks.
6. Check for structural failures. Any damaged parts must be replaced.

Check air cleaner restriction by connecting a vacuum gage or water manometer to the restriction indicator tap on the air cleaner outlet pipe. This restriction should be measured with the engine running at high idle. If the initial restriction (with new or clean elements) measures higher than 19 inches of water, check the following items:

1. Make sure the air cleaner inlet is not plugged.
2. Check the safety element to be sure it is not plugged.
3. Inspect the air cleaner outlet to be sure it is not plugged.
4. Make sure the correct size connections are used between the air cleaner and 5. Make sure that all inlet accessories are the correct size, and are not plugged by any foreign object.

COOLING SYSTEM. (Illus. 4-7).

The following paragraphs point out several facts about Cooling System Components, the affects of Cooling System neglect, and procedures to be followed for Cooling System maintenance.

Rust Prevention.

To keep engines operating to new truck efficiency, all forms of rust formation must be prevented. The formation of rust in the cooling system is a result of water, iron, and oxygen and can only be prevented by maintaining full strength

corrosion protection at all times. For rust protection during the winter months an antifreeze having a corrosion preventive should be installed in the fall. When spring arrives, drain the old antifreeze solution from the Cooling System as all corrosion inhibitors are weakened and may be entirely exhausted, depending on how the truck has been taken care of and how far and fast it has been driven. To rust proof the Cooling System for summer driving add a good rust inhibitor with the first fill of clean water in the spring. This solution should then be drained in the fall and a fresh filling of chemically treated antifreeze installed. A good quick test to determine if Cooling System needs cleaning or flushing due to rust, scale or grease is to wipe the inside of the filler neck and header tank with the finger. If any sludge or excessive rust and scale are present and evidenced by this test, the system needs a thorough cleaning.

Seasonal Care.

The Cooling System of any truck should be drained and flushed out at least once a year. Unless the cooling water or antifreeze has a corrosion preventive, rust and scale will eventually clog up the Cooling System. If no recommended cleaning solution is available when cleaning the system dissolve four pounds of washing soda in water and fill the complete Cooling System. Leave the radiator cap off and run the engine until it is hot. Then disconnect the radiator outlet hose so all sediment will pass through the outlet pipes. and flush thoroughly with clean water.

NOTE

REMOVE RADIATOR CAP WHEN DRAINING SYSTEM TO ASSURE PROPER DRAINING.

Cleaning.

1. Coolant shut-off cocks to heaters and other accessories should be open to allow complete circulation during cleaning, flushing and draining. Run the engine with radiator covered if necessary until temperature is up to operating range (160 degrees to 180 degrees F). Stop engine, remove radiator cap and drain system by opening drain cocks on radiator and crankcase.
2. Allow engine to cool, close drain cocks and pour cleaning compound into radiator according to directions. Fill system with water.
3. Place a clean drain pan to catch overflow, and use to maintain level in radiator. Do not spill solution on vehicle paint.
4. Replace radiator cap and run engine at moderate speed covering radiator if necessary, so that radiator core reaches a temperature of 180 degrees F, or above, but does not reach the boiling point. Allow the engine to run at least two hours at 180 degrees F, so that cleaning solution may take effect. Do not drive vehicle or allow liquid level in radiator to drop low enough to interfere with circulation.
5. Stop engine as often as necessary to prevent boiling.
6. With the engine stopped, feel the radiator core with bare hands to check for cold spots, and then observe temperature gage reading. Where there is no change in temperature for some time, drain the cleaning solution.
7. If clogging of core is relieved but not fully corrected allow the engine to cool, pressure-flush the system and repeat cleaning operation.

8. If clogging or core, indicated by low temperature spots on core, is not relieved, radiator core must be removed for mechanical cleaning. Mechanical cleaning requires removal of upper and lower tanks and rodding out the accumulation rust and scale from the water passage of the core.

Pressure Flushing.

1. Disconnect the upper radiator hose which connects radiator core to engine water outlet, and remove thermostat from engine water outlet.
2. Clamp a convenient length of hose to the radiator core outlet opening, and attach another suitable length of hose to the radiator inlet opening to carry away the flushing stream.
3. Connect the flushing gun to compressed air and water pressure, and clamp the gun nozzle to the hose attached to the radiator outlet opening.
4. With radiator cap on tight, fill core with water. Turn on air pressure in short blasts to prevent core damage.
5. Continue filling radiator with water and applying air pressure as above until the water comes out clear.
6. Clamp the flushing gun nozzle firmly to a hose attached securely to the engine water outlet opening. Fill engine block with water, partly covering water inlet opening to permit complete filling.
7. Turn on compressed air to blow out water and loose sediment. Continue filling with water and blowing out with air until flushing stream comes out clear.
8. For badly clogged engine water jackets that do not respond to regular pressure flushing, remove engine cylinder head and core hole plugs and with a suitable length of small copper tubing attached to the flushing gun nozzle, flush the water jackets through openings.
9. When the vehicle is equipped with a heater connected to the Cooling System, = flush the heater, following same procedure as for radiator core.
10. After completing the flushing operation, clean out radiator overflow pipe, inspect the water pump, clean the thermostat and the radiator cap control valves. Check thermostat for proper operation before installation.
11. Blow insects and dirt from radiator core air passages, using water, if necessary, to soften obstructions.

INSPECTION

Radiator.

1. Top and Bottom Tank. Look for leaks, particularly where tank is soldered to core. Vibration and pulsation from pressure can fatigue soldered seams.
2. Filler Neck. The sealing seat must be smooth and clean. Cams on filler neck must not be bent or worn so as to allow loose fitting cap. Make sure overflow tube is not plugged.

When removing the pressure type cap from the radiator, perform the operation in two steps. Loosening the cap to its first notch raises the valve from the gasket and releases the pressure through the overflow pipe. In the first stage position of the cap it should be possible to depress the cap approximately 1/8-inch. The prongs on the cap can be bent to adjust this condition. Care must be taken that the cap is not too loose as this would prevent proper sealing.

CAUTION

WHEN REMOVING THE CAP, LOOSEN IT SLOWLY AND THEN PAUSE A MOMENT. THIS WILL AVOID POSSIBLE BURNING BY HOT WATER OR STEAM. CONTINUE TO TURN THE CAP TO THE LEFT UNTIL YOU CAN REMOVE IT.

3. Tubes. Because these are very small they can become easily clogged, or partially so, by rust and scale. The general condition of the Cooling System Components and operating temperature are indications as to whether or not tubes are clean. Another good test is to feel core for cold spots.
4. Fins. These thin metal sheets radiate or pass off heat picked up by tubes. They should be kept free of foreign matter, so as to allow the free passage of air. Bent fins should be straightened.

Engine Water Jacket.

The water jacket permits coolant to be circulated around the cylinder walls, combustion chamber, and valve assemblies. Some of these coolant passages are small and can easily become clogged if Cooling System does not receive the proper maintenance.

1. Core Plugs. These are some times mistakenly called freeze plugs. They do not provide protection against freezing expansion but are only present because of engine block casting methods. Remove and replace core plugs that show signs of leaking or rusting through. Use installing tool for core plug replacement.
2. Drain Plugs. The water jacket of each engine has one or more drain plugs. These should receive seasonal care and kept free of rust and scale.
3. Gaskets. Must be in good condition to prevent both internal and external leaks. If there are external leaks around gaskets, there may also be internal leaks. Proper tightening of the head bolts with a torque wrench is essential for preventing leaks around head gaskets.

Water Pump.

The water pump which circulates coolant through the Cooling System is likewise a most essential part. The pump should be checked carefully for leaks and proper lubrication, and if leaking, cracked or in bad condition, it should be rebuilt or replaced promptly.

Fan and Belts.

The fan should be checked for loose or bent blades. A loose blade might work free during operation and cause damage. A bent blade will reduce the fans efficiency.

Fan belts must be adjusted for proper tension. A belt adjustment that is just tight enough to prevent slipping on pulleys may be considered a proper adjustment. A tight belt adjustment is to be avoided since this will damage generator bearings. When one belt of dual drives is damaged or worn, they must both be changed as a matched pair.

Thermostat.

Thermostats used in these trucks are of the nonadjustable type and are incorporated in the Cooling System for the purpose of retarding or restricting the

circulation of coolant during engine warm up.

Engine overheating and loss of coolant is some times due to an inoperative thermostat. To check for this condition remove thermostat and test by submerging in hot water noting temperature at which thermostat opens or closes. Use an accurate high temperature thermometer for making this test.

Hose and Clamps.

Hoses and their connections must be checked regularly because they are often the source of hidden trouble and can often times appear in good condition on the outside while the inside will be partially deteriorated. If there are any doubts about a hose doing its job, replacement should be made. The clamps should be inspected to make sure they are strong enough to hold a right connection.

TEST EQUIPMENT.

To aid the service man in maintaining the Cooling System at top efficiency, various items of test equipment are available. Among these are the Cooling System Tester and the Hydrometer.

1. Hydrometers. Hydrometers which are used to test freezing protection of an antifreeze solution, work on the principle of specific gravity or weight of the antifreeze solution. They are simple to use provided they are used in the proper manner. When using hydrometer, the solution must be warm (at least 110 degrees), the temperature and level must be noted correctly, and the float must be able to move freely. Read only the hydrometer scale corresponding to type antifreeze solution in the radiator. Keep hydrometer clean inside and out and treat it with the same care as given any other precision instrument.

NOTE

HYDROMETERS DO NOT CORRECTLY REGISTER THE FREEZING PROTECTION OF A MIXTURE METHANOL AND GLYCOL BASE ANTIFREEZE. THEREFORE, ALWAYS FLUSH THE COOLANT SYSTEM WITH THERMOSTAT REMOVED BEFORE ADDING ANTIFREEZE FOR THE WINTER.

COOLANT RECOMMENDATIONS.

1. Always use a proper inhibited coolant.
2. If freeze protection is required, always use ethylene glycol antifreeze.
3. Reinhibit antifreeze with a non-chromate inhibitor.
4. Always follow the manufacturer's recommendations on inhibitor usage and handling.
5. Do not use soluble oil.
6. Chromate inhibitors should NEVER be used with permanent antifreeze.
7. Sealer type antifreeze should NOT be used.
8. Maintain prescribed inhibitor strength.

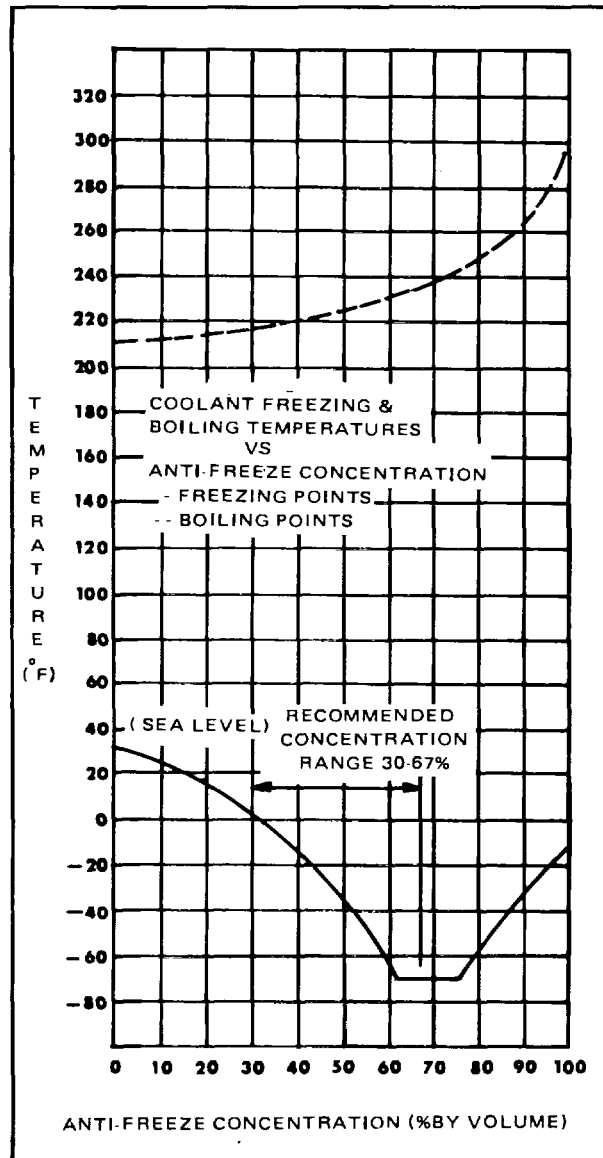

Illustration 4-24. Antifreeze Concentration Chart

TROUBLESHOOTING.

Listed below are troubles that may occur in the Coolant System.

TROUBLE	PROBABLE CAUSE	REMEDY
Engine overheating.	<p>Radiator air flow obstructed: Leaves, dirt and foreign material. Bent fan blades.</p> <p>Improper or damaged thermostat. Improper valve timing or sticking valves.</p> <p>Clogged muffler or pipe. Stiff rebuilt engine. Dragging brakes.</p> <p>Low engine oil level.</p> <p>Engine overloaded.</p>	<p>Clean away obstruction. Straighten blades or replace fan. Replace thermostat.</p> <p>Check and repair or re-time engine. Check and correct.</p> <p>Check brakes and repair as required. Check and add oil as required. Operate engine in proper load range.</p>
Overcooling.	<p>Thermostat not installed Damaged thermostat stuck open Short runs and intermittent driving.</p>	<p>Install thermostat. Replace thermostat.</p>
Engine overheating.	<p>Coolant loss due to: Leaks at any of the following: gaskets, hose connections, water pump, radiator, heater, worn plugs, drain cock or plugs, cracked head or block.</p> <p style="text-align: center;">NOTE</p> <p>INTERNAL LEAKAGE IS INDICATED BY THE PRESENCE OF COOLANT IN THE ENGINE CRANKCASE, OR OIL IN THE RADIATOR. CHECK FOR CRACKED CYLINDER HEAD OR BLOCK, OR A BLOWN HEAD GASKET.</p> <p>Boiling - may be caused by any of the following: Radiator or other parts of cooling system clogged with rust or scale. Grille or bug screen clogged Radiator core fins damaged Thermostat damaged - stuck closed.</p>	<p>Check, locate, and repair leaks. Replace hoses, clamps, and other parts as required.</p> <p>Drain and flush cooling system.</p> <p>Clear obstructions. Straighten fins. Replace thermostat.</p>

TROUBLESHOOTING.

TROUBLE	PROBABLE CAUSE	REMEDY
Engine overheating (continued).	<p>Water pump leaking air into system. Radiator hose collapsed or rotting inwardly. Radiator pressure cap damaged. Cylinder head loose, causing exhaust gas leakage into cooling system. Water pump impeller corroded or loose on shaft. Antifreeze protection inadequate, causing partial freeze-up. After-boil: Improper installation of thermostat. Damaged thermostat. High temperature thermostat used with alcohol-type antifreeze.</p> <p>Excessive sediment in cooling system. Foaming: Excessive sediment in cooling system. Air or exhaust leak into cooling system. Evaporation: Faulty pressure cap. Alcohol base antifreeze.</p> <p>Broken or loose fan belt.</p> <p>Radiator clogged.</p> <p>Hose collapsed or clogged. Damaged pressure cap. Worn or corroded impeller on water pump.</p>	<p>Repair water pump. Replace radiator hoses. Replace cap. Check and tighten.</p> <p>Repair water pump. Check and add antifreeze as required. Check and correct. Replace thermostat. Use thermostat of proper operating range; use ethylene-glycol type antifreeze. Drain and flush cooling system.</p> <p>Drain and flush cooling system. Check, locate, and repair.</p> <p>Replace pressure cap. Use ethylene-glycol type antifreeze. Replace or tighten, as required. Drain and flush cooling system. Replace all hoses. Replace cap. Replace water pump impeller and seals.</p>
FUEL SYSTEM.		

The carrier fuel tank should be kept filled, especially overnight, to reduce condensation to a minimum. Open the drain at the bottom of the fuel tank every 500 operating hours to drain off any water or sediment.

Fuel Strainer and Filter Check.

Daily drain approximately a cup of fuel from the fuel strainer and filter to

remove any water or sediment. Install new filter elements every 300 hours of operation or more often if plugging is indicated. A plugged filter can be detected by observing the fuel pressure at the cylinder head fuel inlet manifold and the inlet restriction at the fuel pump. In a clean system, the maximum pump inlet restriction should not exceed 6 inches of mercury. At normal operating speeds (1600-2100 rpm) the fuel pressure is 45-70 psi. Change the fuel filter elements whenever the inlet restriction (suction) at the fuel pump reaches 12 inches of mercury at normal operating speeds (1600-2100) and whenever the fuel pressure at the inlet manifold falls to 45 psi.

Fuel Strainer and Filter Elements Replacement. (Illus. 4-4).

1. With the engine shut down, place a container under the strainer or filter and open the draincock. Loosen the cover nut or bolt just enough to allow the fuel oil to drain out freely.

CAUTION

THE WIRING HARNESS, STARTING MOTOR, OR OTHER ELECTRICAL EQUIPMENT SHOULD BE COVERED DURING THE FILTER CHANGE, SINCE FUEL OIL CAN DAMAGE THE ELECTRICAL INSULATION.

2. While supporting the shell, unscrew the cover nut or bolt and remove the shell and the element.
3. Remove and discard the element, the shell gasket, the cover nut or bolt gasket.

CAUTION

ONLY FILTER ELEMENTS DESIGNED FOR FUEL OIL FILTRATION SHOULD BE USED TO FILTER THE FUEL.

4. Wash the shell thoroughly with fuel oil and dry it with compressed air.
5. Examine the element seat and the retaining ring to make sure they have not slipped out of place. Check the spring by pressing on the element seat. When released, the seat must return against the retaining ring.

NOTE

THE ELEMENT SEAT, SPRING, WASHER AND SEAL CANNOT BE REMOVED FROM THE STRAINER SHELL. IF NECESSARY, THE ASSEMBLY MUST BE REPLACED. HOWEVER, THE COMPONENTS OF THE FILTER SHELL ARE SERVICED. EXAMINE THE FILTER RETAINER SEAL FOR HARDENING OR CRACKING. IF NECESSARY, REPLACE THE SEAL.

6. Place a new element over the stud and down against the seat. Make sure the draincock is closed; then, fill the shell about two-thirds full with clean fuel oil.

NOTE

THOROUGHLY SOAK THE DENSITY-TYPE STRAINER ELEMENT IN CLEAN FUEL OIL BEFORE INSTALLING IT. THIS WILL EXPEL ANY AIR ENTRAPPED ELEMENT AND IS CONDUCIVE TO A FASTER START.

7. Install a new gasket in the recess of the shell.
8. Place the shell and element in position under the cover. Then, with a new gasket over the cover bolt, thread the bolt (or nut) into the stud.
9. With the shell and gasket properly positioned, tighten the cover bolt or nut just enough to prevent leakage.
10. Remove the filter plug in the cover and complete filling of the shell with fuel. Primer J5956 may be used to prime the entire Fuel System.
11. Start the engine and check the Fuel System for leaks.

TROUBLESHOOTING.

Listed below are problems and solutions for troubles that may occur in the Fuel System.

TROUBLE	PROBABLE CAUSE	REMEDY
Fuel not reaching injection pump. Engine fails to start.	Tank empty or tank valve closed. Primary or secondary filter plugged. Shutoff valve closed. Fuel lines clogged or damaged. Defective transfer pump. pump.	Fill tank; open valve. Replace filters. Open shut-off valve. Clean or replace fuel lines. Replace transfer
Fuel reaches nozzles but engine fails to start or starts hard.	Cranking speed too slow. Intake air temperature low. Improper fuel or water in fuel. Accelerator not in full fuel position.	Recharge battery or correct faulty cranking motor system. Lube oil may be too heavy at low temperature. Use starting aids. Check ether device for proper operation. (Check Operator's Manual). Drain fuel system and pump housing. Use specified fuel and prime system. Correct accelerator linkage.
Engine starts and stops.	Water in fuel or contamination. Air in system. Fuel filter clogged. Waxed fuel filters. Fuel lines clogged or damaged.	Drain system and pump housing. Use new fuel and prime system. Prime system. Replace filters. Use proper fuel. Clean or replace fuel lines.

TROUBLESHOOTING

TROUBLE	PROBABLE CAUSE	REMEDY
Erratic engine operation (surging or misfiring).	Improper or contaminated fuel. Transfer pressure too low. Fuel filters clogged. Fuel lines clogged or damaged. Injection pipes leaking.	Drain system. Use new fuel and prime system. Change filters or make transfer pressure adjustment. Replace filters. Clean or replace fuel lines. Correct leaks.
Engine idles poorly.	Water in fuel. Air in fuel. Governor linkage incorrect. Incorrect timing.	Drain system and pump housing. Use new fuel and prime. Bleed system. Correct governor as required. Check timing.

Engine and Transmission Mounts. (Illus. 4-25).

Illustration 4-25 shows the location of the engine and transmission mounts. Inspect the mounts for deterioration when servicing the engine. Do not allow mounts to become oil soaked. Mounting bolts should be checked for proper torque each 1,000 hours.

Constant Speed Pump Drive.

REMOVAL (Illus. 4-26).

1. Remove hydraulic pumps and mechanical linkage from drive. Refer to Superstructure hydraulic pumps.
2. Remove propeller shaft from drive.
3. Remove bolts that secure drive to Carrier frame.
4. Remove drive from Carrier.

DISASSEMBLY. (Illus. 4-27).

Disassemble in accordance with the index numbers.

REASSEMBLY.

Reassembly is the reverse of disassembly.

INSTALLATION.

Installation is the reverse of removal. Therefore no procedures are provided.

HYDRAULIC PUMP DRIVE

DESCRIPTION

The hydraulic pump drive gearbox is located behind the front bumper of the carrier. in front of the engine. The engine drives the gearbox using a short driveline connected to the front crankshaft pulley and a companion flange on the input shaft of the gearbox.. The driveline rotates as the engine runs. A cable running from the cab to the gearbox allows the pumps to be engaged or disengaged.

The splined connector is pulled into the splined center of the pinion gear to engage the pumps. It is pushed back into the input shaft to disengage the pumps. A small shaft (shift shaft) goes through the splined connector and out through the front of the case. A control cable is connect to the shaft to permit remote control of the disconnect.

The input shaft is mounted in the bearing support housing. The input shaft is one piece. It is splined inside and is flanged on one end. The pinion gear is supported by the bearing support housing. This pinion gear is also splined inside so it can mate with the connector assembly.

The pinion gear drives two output pinion gears. These gears are splined on the inside. Adaptor sleeves are used to mate the output pinion gears with the input shaft of each pump. Both pumps turn at the same speed and both in a counterclockwise direction.

MAINTENANCE

TROUBLESHOOTING.

SYMPTOM	PROBABLE CAUSE	SOLUTION
1. Oil overflow from the breather	a Overfilled b The hydraulic pump shaft seal is leaking oil.	a Drain to the proper level. b Repair the hydraulic pump.
2. Seals leaking.	a Overfilled b The hydraulic pump shaft seal is leaking oil.	a Drain to the proper level. b Repair the hydraulic pump.
3. Vibration.	a. Loose drive shaft. b. Bad bearings in either the input shaft, the pinion gear, or the output pinion gear(s). c Engine malfunction d Bent driveline or worn universals. e Driveline out of balance f Worn gears	a. Tighten the flange bolts (on both ends). b. Inspect and replace as necessary. c Repair as necessary. d Repair or replace as necessary. e Balance the drive shaft. f Replace as necessary.
4. Noise.	a Worn gears or bearings	a Replace as necessary.

This page intentionally left blank.

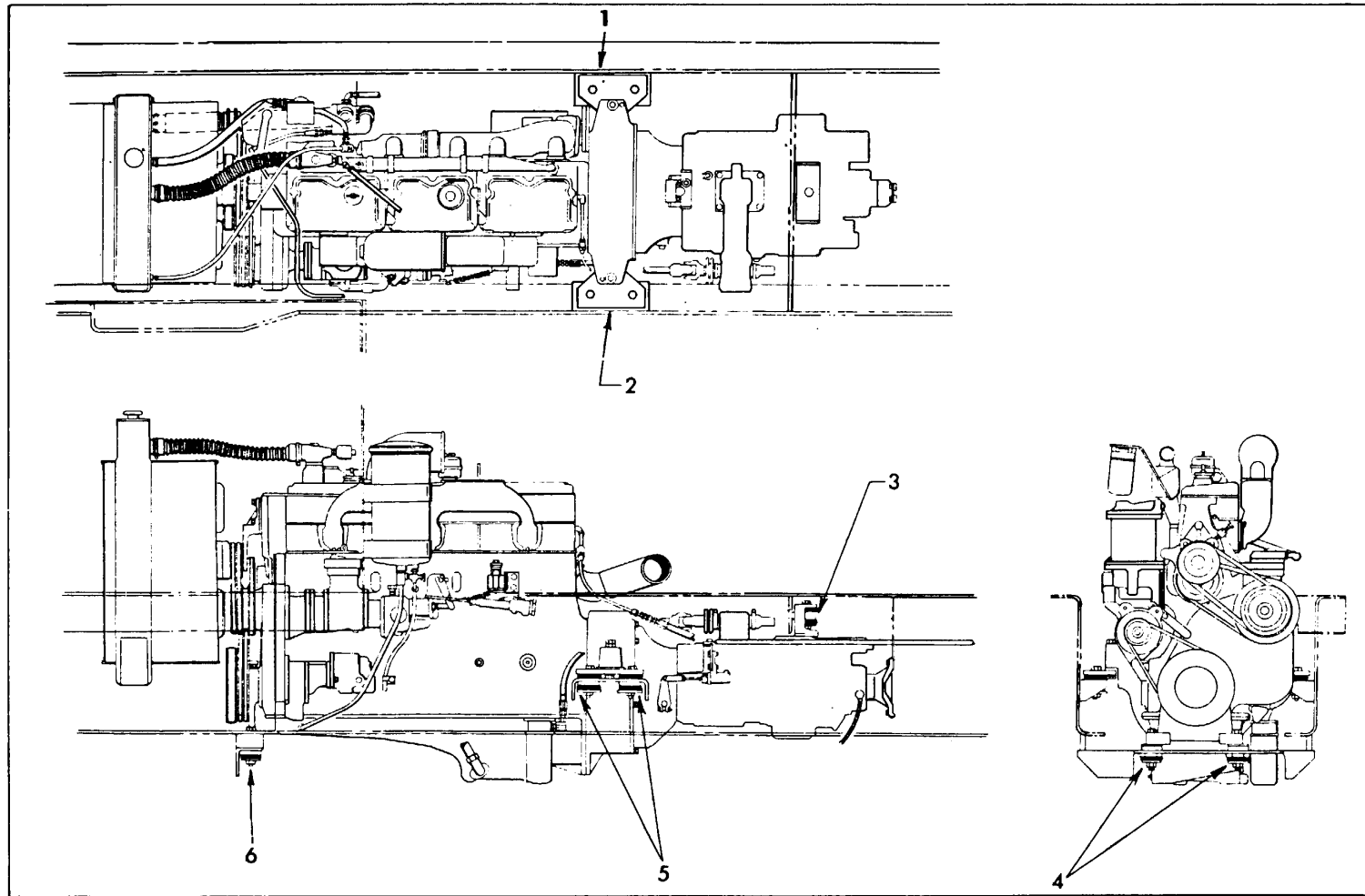

1. Right Engine Mount
2. Left Engine Mount
3. Transmission Mount
4. Left and Right Front Engine Mounts
5. Left Engine Mounts (Right Side Same)
6. Left Front Engine Mount

Illustration 4-25. Engine and Transmission Mount Locations.

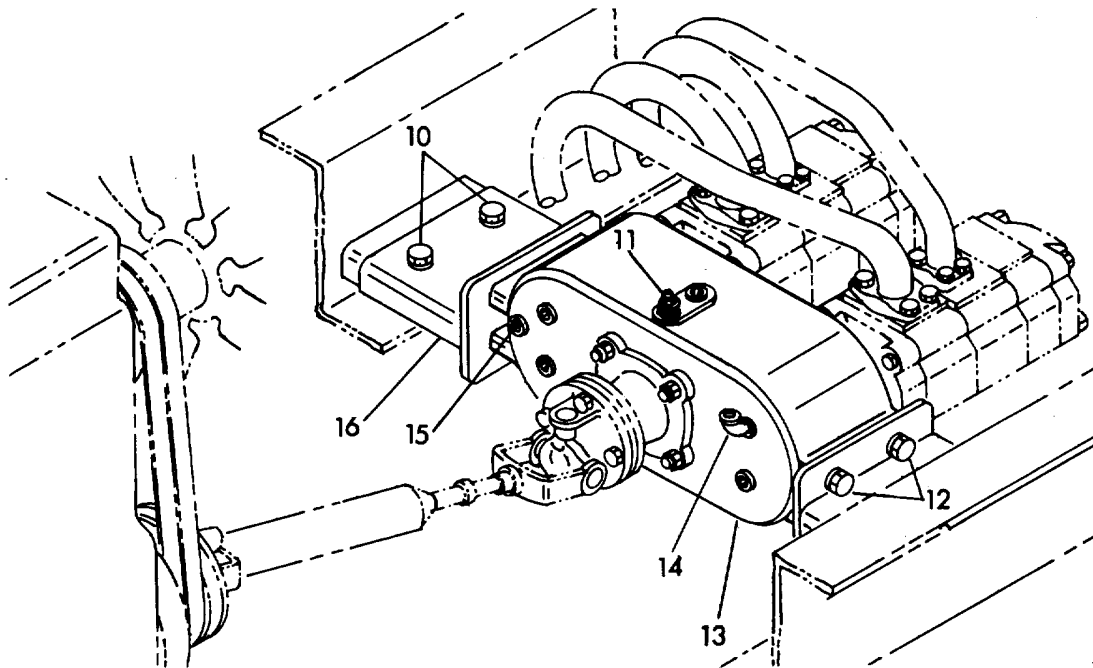
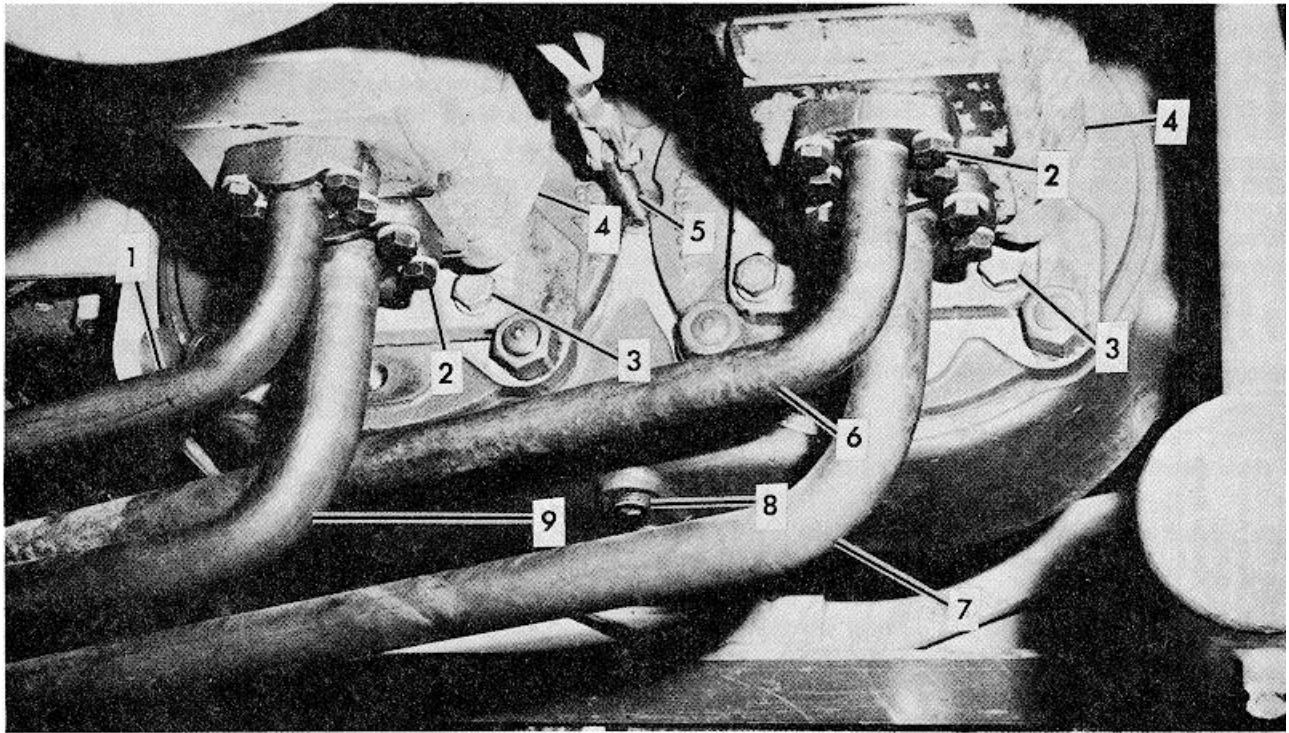

- | | |
|---|-------------------------------|
| 1. Hydraulic Lines | 9. Hydraulic Lines |
| 2. Hydraulic Lines Attachment Bolts | 10. Mounting Bolts |
| 3. Hydraulic Pump Attachments Bolts | 11. Breather Plug |
| 4. Hydraulic Pump | 12. Mounting Bolts |
| 5. Mechanical Linkage | 13. Constant Speed Pump Drive |
| 6. Hydraulic Lines | 14. Filler Plug |
| 7. Hydraulic Lines | 15. Oil Change Plug |
| 8. Constant Speed Pump Drive Drain Plug | 16. Mounting Bracket |

Illustration 4-26. Constant Speed Pump Drive Removal

- | | | | | | | |
|-------------------------|-----------------------------|--------------------|--------------------------|------------------------|--------------------|------------------------|
| 1. Snap Ring | 7. Bearing | 13. Plug Expansion | 19. Pinion Gear | 25. Bearing | 31. O-Ring | 37. Oil Seal |
| 2. Backup Washer | 8. Snap Ring | 14. Input Shaft | 20. Bearing | 26. Output Pinion Gear | 32. Adaptor Sleeve | 38. Output Pinion Gear |
| 3. Bronze Thrust Washer | 9. Bearing | 15. Nut | 21. Plug | 27. O-Ring | 33. Nut | 39. Detent Ring |
| 4. Connector Shaft | 10. O-Ring | 16. Lockwasher | 22. Plug Oil Level Check | 28. Pump Adaptor | 34. Washer | 40. Shift Shaft |
| 5. Roll Pins | 11. Support Bearing Housing | 17. Stud | 23. Gearbox | 29. O-Ring | 35. Stud | 41. Breather |
| 6. Snap Ring | 12. Oil Seal | 18. Bearing | 24. Drain Plug | 24. Drain Plug | 36. Pump Adaptor | 42. Reducing Bushing |

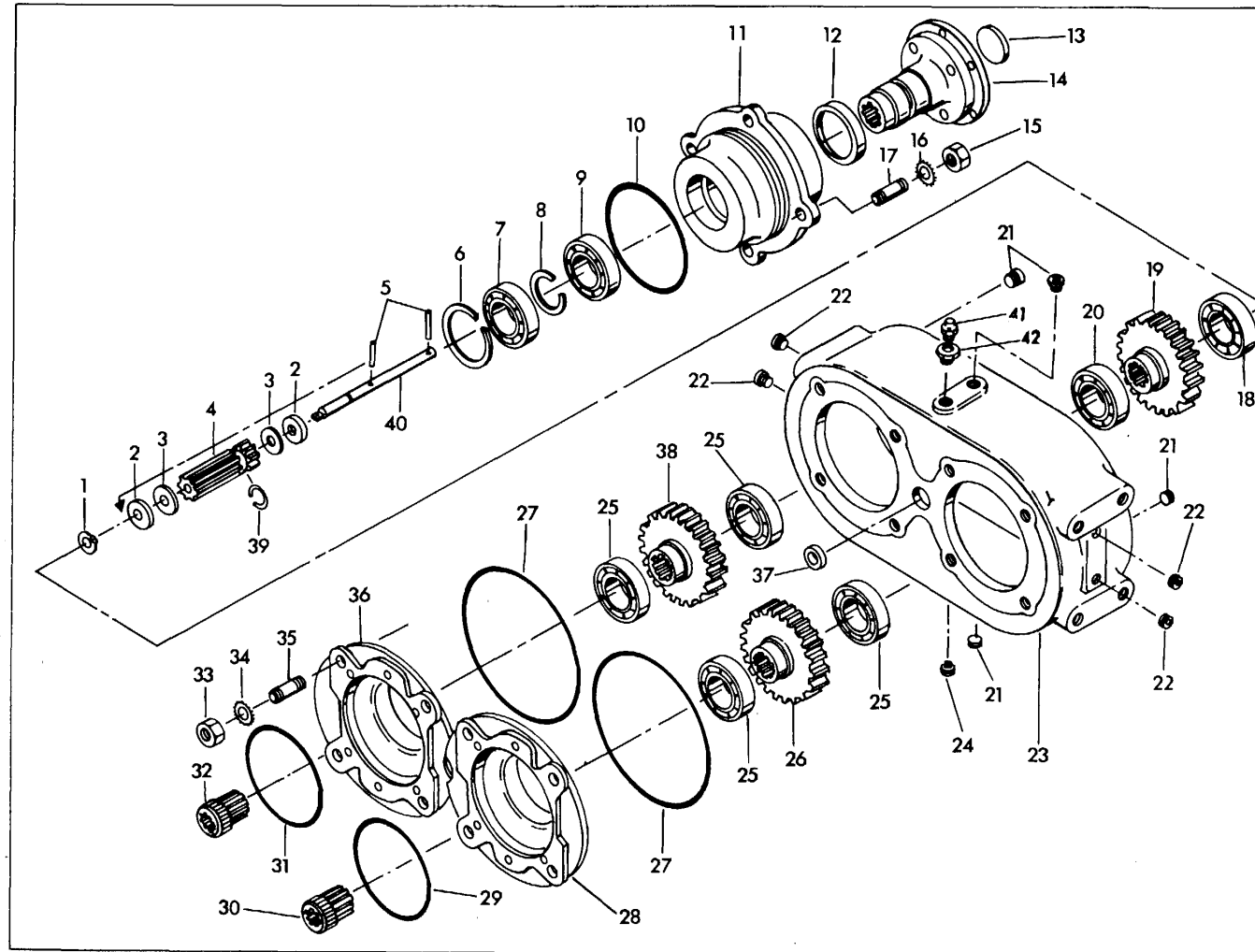

Illustration 4-27. Constant Speed Pump Drive Disassembly.

NOTE

The pump drive does not have to be removed from the crane to service the input shaft or du bearing support housing assembly. To service the output pinions or bearings, remove the pump drive from the crane.

1. Drain the oil from the pump drive.
2. Remove the pumps. Refer to Hydraulic Pumps.
3. Disconnect the cable from the shift shaft.
4. Remove the bolts securing the yoke flange to the Input shaft
5. Remove the four mounting bolts holding the mounting bracket to the frame.
6. Remove the pump drive.

DISASSEMBLY.

NOTE

The pump drive does not have to be removed from the crane to service the input shaft and bearing support housing assembly. To service the output pinions or bearings, remove the pump drive from the crane.

1. Remove the four nuts (15) holding the input shaft (14) and support bearing housing (11) in the gearbox (23).
2. Remove the input shaft (14) and support bearing housing (11).
3. If the pinion gear (19) comes out with the input shaft assembly, remove it from the end of the input shaft (14).
4. Remove the connector shaft assembly (4) from the input shaft assembly.

NOTE

Do not disassemble the input shaft (14) and support bearing housing (11) assemblies unless there is a need to replace one of the component parts. Steps 5 through 8 refer to this disassembly.

5. Remove the large outer snap ring (6) from the support bearing housing (11).

NOTE: On some machines It is very difficult to remove the input shaft (14) from the bearing support housing (11). Snap rings in the bearings and housings are nearly impossible to remove without destroying the front bearing (7). The splined input shaft (14) is held into the bearings by a snap ring between the bearings. Use of a cutting torch should be limited as much as possible. The recommended procedure is to cut the bearing race with a hammer and chisel. Carefully remove the first bearing (7), then the snap rings (6 & 8) can be removed from the input shaft (14). The pump drive unit should be disassembled and inspected for slog damage to other parts after using this procedure.

6. Remove the front bearing (7) from the bearing support housing (11).
7. Remove the snap ring (8) from the input shaft (14).
8. Press the input shaft (14) out of the bearing support housing (11).
9. Press the bearing out of the bearing support housing (11).
10. Remove the seal (12) from the input shaft (14).

NOTE

Do not remove the expansion plug (13) from the end of the input shaft (14) unless it is leaking.

11. Remove the roll pin (5) from the end of the shift shaft (40).
12. Remove the two washers (2 and 3), the connector shaft (4), and the other two washers (2 and 3) from the shift shaft (40).
13. Remove the snap ring (1) from the shift shaft (40) and the detent ring (39) from the connector shaft (4).
14. Remove the nuts and lockwashers (33 and 34) fastening the pump adaptors (28 and 36).
15. Remove the pump adaptors (28 and 36).
16. Remove the output pinion gears (26 and 38) and pull the bearings (25).
17. Remove the oil seal (37) from the gearbox (23).

CLEANING AND INSPECTION.

CAUTION

DO NOT USE GASOLINE AS A SOLVENT.

1. Thoroughly clean the gearbox and all components in solvent.
2. Inspect all bearings, cups, and races, including those not removed. Replace if the bearings or cups are worn, pitted, or damaged in any way.
3. Inspect all gear teeth and splined shafts for wear or damage.
4. Ensure the breather plug (41) is open.

ASSEMBLY.

1. Press the bearings (25, 20 and 18) on the output pinion gears (26 and 38) and the pinion gear (19).
2. Install the pinion gear (19) and the output pinion gears in the gearbox (23).

NOTE

These gears do not have to be timed.

3. Install the pump mounting adaptors (28 and 36), lockwashers (34), and nuts (33) and tighten securely.
4. Install the shift shaft oil seal (37).
5. Install the detent ring (39) on the connector shaft (4). Install a steel backup washer (2) and then a bronze thrust washer (3) on the shift shaft (40).
6. Ensure the bronze thrust washer is next to the connector shaft on the shift shaft.
7. Install the connector shaft (4) on the shift shaft (40) with the long end toward the remaining roll pin.
8. Install the bronze thrust washer (3) next to the connector shaft. Install a steel backup washer next to the bronze backup washer.
9. Install the roll pin (5) in the mounting hole in the shift shaft (40).
10. Place the shift shaft snap ring (1) in the shift shaft snap ring groove.

NOTE

If the input shaft assembly has been disassembled, adhere to the following steps, otherwise proceed to step 16.

11. Install the oil seal (12) in the bearing support housing (11).
12. Press the inner bearing (9) into the bearing support housing (11).
13. Press the input shaft (14) into the bearing support housing (11).
14. Install the snap ring (8) in the groove on the input shaft (14).
15. Press the outer bearing (7) into the support bearing housing (11).

NOTE

On some machines the snap ring (6) must be installed in the bearing support housing (11) before the bearing is installed.

16. Install the shift shaft assembly in the input shaft (14).
17. Install the support bearing housing assembly in the gearbox (23), install the lockwashers (16) and nuts, and tighten securely.

INSTALLATION.

1. Install the pump drive on the frame mounting bracket; install the bolts, lockwashers, and nuts, and tighten securely.
2. Mount both pumps on the pump drive: install the lockwashers and bolts, and tighten securely. Connect the plumbing as tagged prior to removal.
3. Fill to the proper level. Refer to Servicing this section.
4. Install the cable on the shift shaft.
5. Mate the yoke flange and the input flange, and install the bolts, washer, and nuts.

SERVICING.

The rear of the box (the side with the input flange) has two plugs on the right side and three plugs on the left side. The oil level must be high enough to run out the bottom of the center hole on the left side. Use 90 weight EP gear oil.

This page intentionally left blank.

CHECKING OIL LEVEL.

1. Stop engine before checking or adding oil.
2. Clean around oil fill before checking or adding oil.
3. It is recommended that lubricating oil be changed after the first 50 hours of service.
4. Thereafter, and under normal operating conditions, it is recommended that the oil be changed after every six months of operation. The oil in the unit should be changed whenever the oil shows traces of dirt or effects of high temperature, evident by the discoloration or strong odor.
5. Drain dirty oil while the unit is still warm, examining for contamination or metal particles.
6. Clean all magnetic drain plugs before replacing.
7. Always use clean oil in clean containers.
8. Do not overfill. This will result in overheating and possible malfunction of the unit. The oil capacity is 5 1/2 quarts.
9. Fill with EP-90 oil or equivalent. This applies to all models.

TRANSMISSION SYSTEM.

NOTE

THE SLAVE UNIT AND GEAR SHIFT LINKAGE MUST BE REMOVED PRIOR TO REMOVAL OF THE TRANSMISSION.

DRAINING OIL. (Illus. 4-28).

To drain the transmission remove the two drain plugs. Drain oil when transmission is warm. After the transmission has been drained and before it is refilled, the case should be thoroughly flushed with a clean flushing oil or kerosene. Clean both drain plugs before reinstalling.

REMOVAL (Illus. 4-8).

1. Remove Slave Unit and Gear Shift Linkage.
2. Attach sling to transmission.
3. Remove clutch mechanical linkage and disconnect electric wires from transmission sensors, and air lines.
4. Remove bolts that secure transmission to engine.
5. Remove transmission from engine.

INSTALLATION.

Installation is the reverse of removal. Therefore no installation procedures are provided.

Slave Unit and Gear Shift Linkage.

REMOVAL.

1. Shift the transmission to neutral. If the vehicle is equipped with an air shifted transmission or two speed axle bleed the air reservoirs and disconnect the nylon tubing at the range shift valve on the gearshift lever. Disconnect the tubing at the splitter valve.
2. Loosen the clamps and remove the range shift valve. Cut the tape which secures the tubing to the gearshift lever, exercising due caution to avoid cutting the tubing inside.

NOTE

THE RANGE SHIFT VALVE MAY BE REMOVED FROM THE GEARSHIFT LEVER WITHOUT DISCONNECTING THE NYLON TUBING FROM THE VALVE, IF SO DESIRED THIS IS RECOMMENDED IF NO SERVICE IS TO BE PERFORMED ON THE AIR SHIFT PIPING OR VALVES.

3. Loosen the set screws in the universal joints on the shift control shaft (at both ends of the shaft) and remove the shift control shaft.
4. Remove the three capscrews securing the master control unit to the bracket. It may be necessary to remove the knob from the gearshift lever before withdrawing the master control unit from its mounting bracket.

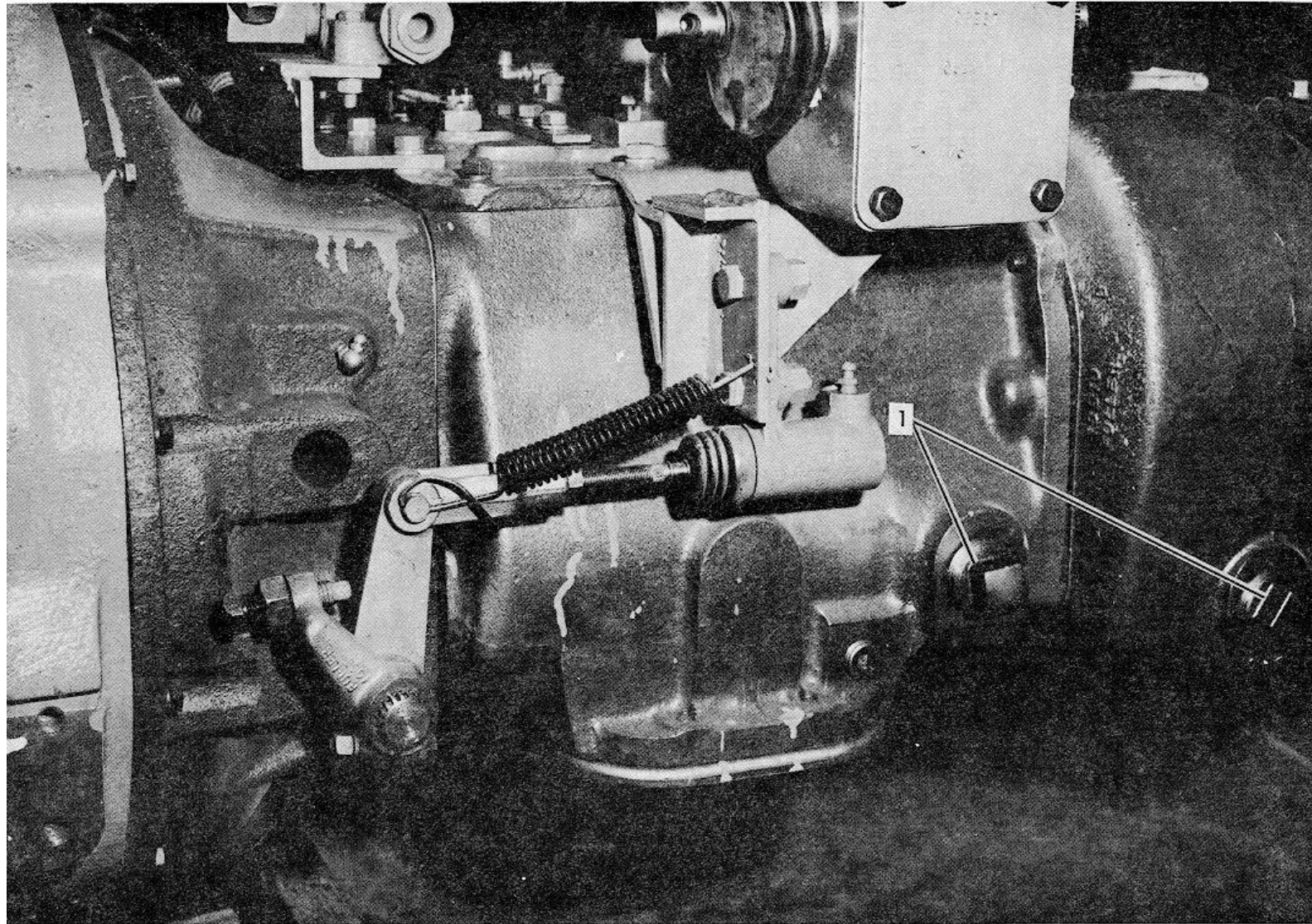

1. Fill and Drain Plugs

Illustration 4-28. Transmission Fill and Drain Plugs.

5. Loosen the locknuts on the slave control unit mounting flange studs. Loosen the hex nuts on the mounting studs, remove all nuts, and lift off the slave control unit.

DISASSEMBLY. (Illus. 4-29).

1. Disassemble the master and slave control units as shown.
2. Discard all gaskets and seals as they are removed.
3. Do not remove scraper bushings (23) from slave housing (24) unless replacement of bushings is necessary.

INSPECTION AND REPAIR.

1. Clean all disassembled parts of the shift control group, using Stoddard Solvent, or similar, cleaning fluid, and examine all parts carefully for the following.
 - a. Worn bores or bushings in housings, yokes and fingers.
 - b. Damaged threads, particularly in all set screw holes.
 - c. Bent shafts (finger shafts, yoke shafts, and shift control shaft).
 - d. Cracked or broken fingers, yokes, and housings.
2. Repair for any of the above conditions is accomplished by replacement of the part found defective.

REASSEMBLY.

1. Reassemble the master control unit and slave unit. Do not install shift control shaft (19) at this time. Use all new gaskets and seals during reassembly.
2. Make certain, during reassembly, that the set screws (39) in the shift fingers (32 and 38) are quite secure before installation of the slave unit on the transmission.
3. Movement of the parts must be free, but not sloppy. Proper assembly and adjustment will provide good "feel" of the shifting pattern for the driver and prevent the possibility of the transmission jumping out of gear.

INSTALLATION.

1. Position the master control unit against its mounting bracket, and install three capscrews and lockwashers to hold the unit on the bracket.

NOTE

IT MAY BE NECESSARY TO REMOVE THE KNOB FROM THE GEARSHIFT LEVER WHEN INSTALLING THE MASTER UNIT ONTO THE MOUNTING BRACKET.

2. Install the slave unit onto the studs in the transmission shift bar cover, making sure that the shift finger engages properly with the shift bars inside the transmission.
3. Position the gearshift lever in neutral (perpendicular) position and install the shift control shaft being careful to maintain the exact position of the slave unit input shaft and the gearshift lever.
4. After installing the shift control shaft and making sure that master and slave unit are synchronized in exact neutral position, tighten the set screws on the shift control shaft universal joint yokes. There are two set screws

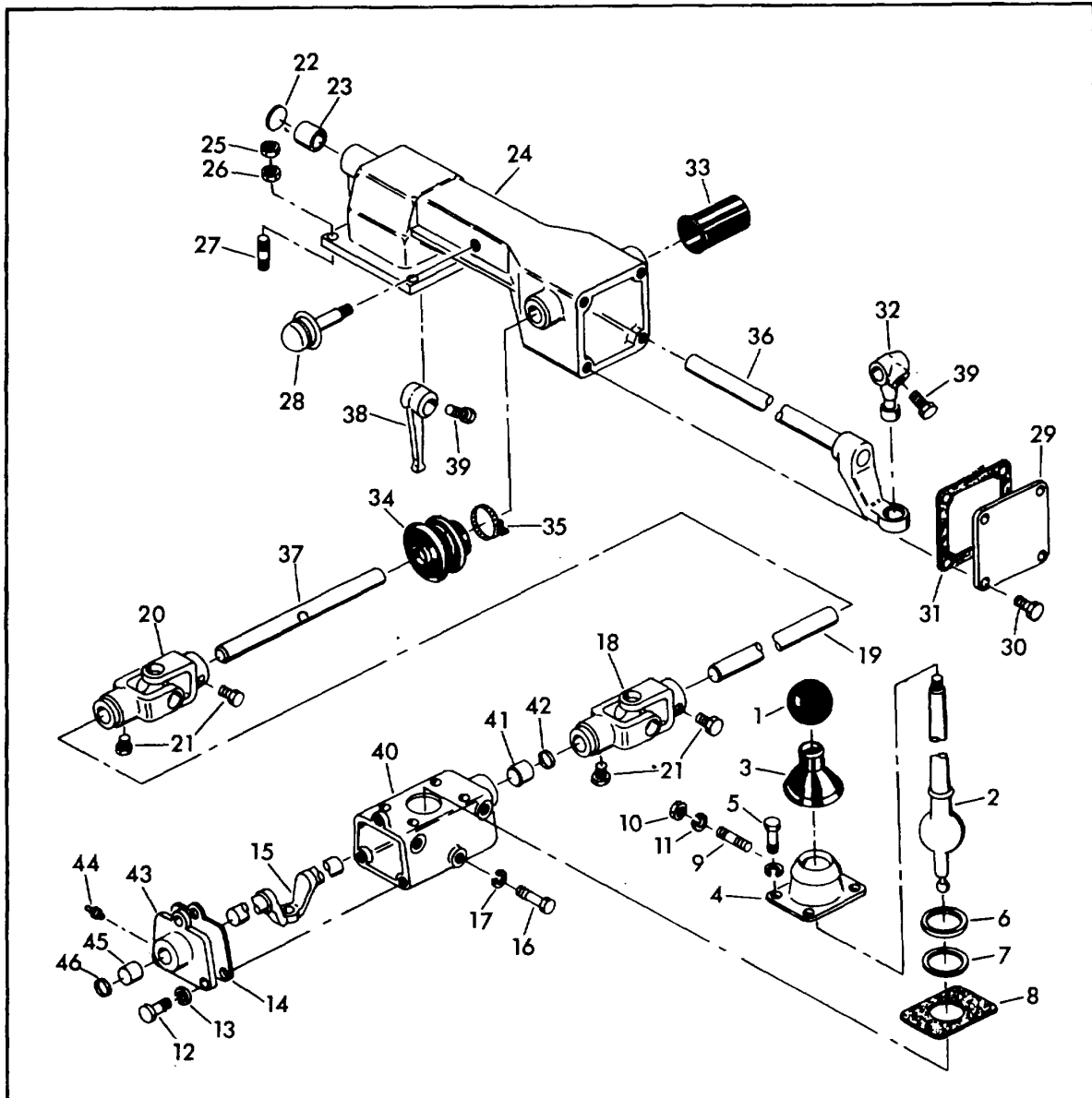

- | | | |
|------------------------|-------------------------|-------------------------|
| 1. Level Ball | 1. Universal Joint | 34. Boot |
| 3. Lever Boot | 19. Shift Control Shaft | 35. Boot Clamp |
| 4. Shift Control Tower | 20. Universal Joint | 36. Shaft and Lever |
| 5. Capscrew | 21. Lockscrew | 37. Outer Shift Shaft |
| 6. Lever Seat | 22. Expansion Plug | 38. Inner Shift Finger |
| 7. Seat Washer | 23. Scraper | 39. Finger Capscrew |
| 8. Tower Gasket | 24. Housing | 40. Housing Assembly |
| 9. Pivot Pin | 25. Hex Nut | 41. Bushing |
| 10. Hex Nut | 26. Hex Nut | 42. Scraper |
| 11. Lockwasher | 27. Stud | 43. Cap |
| 12. Gasket | 28. Breather | 44. Lubrication Fitting |
| 13. Lockwasher | 29. Cover | 45. Bushing |
| 14. Gasket | 30. Capscrew | 46. Scraper |
| 15. Yoke | 31. Gasket | |
| 16. Capscrew | 32. Finger | |

Illustration 4-29. Gear Shift Linkage

- on each yoke mounted at 90 degrees to each other. Lockwire these set screws after tightening.
5. Lubricate the master control unit with chassis lube after installation. The lube fitting is located in the cap just under the shift control shaft.

Range Control Valve.

DISASSEMBLY (Illus. 4-30).

The range control valve is disassembled by removing the top plate screw.

REASSEMBLY.

Reassembly is the reverse of disassembly. Critical assembly factors are:

1. Make sure that the jam nut locking the control valve to the shifting lever is secure.
2. Make sure that, when reassembled, the top plate screw is torqued with 90 to 120 inch-pounds. A loose top plate screw can affect valve operation.
3. When reassembling, lubricate the O-ring and O-ring carrier with a barium base grease.

TROUBLESHOOTING.

Troubleshoot the valve by checking air flow from the ports listed below.

1. Porting There are four ports in the bottom of the control:
 - a. The port stamped "S" is the supply port and is the constant air line from the air valve.
 - b. The port stamped "E" is the exhaust port and is left open.
 - c. The port stamped "R" is the signal line to the slave air valve.
 - d. The port stamped "F" is the signal line to the intermediate shift cylinder.

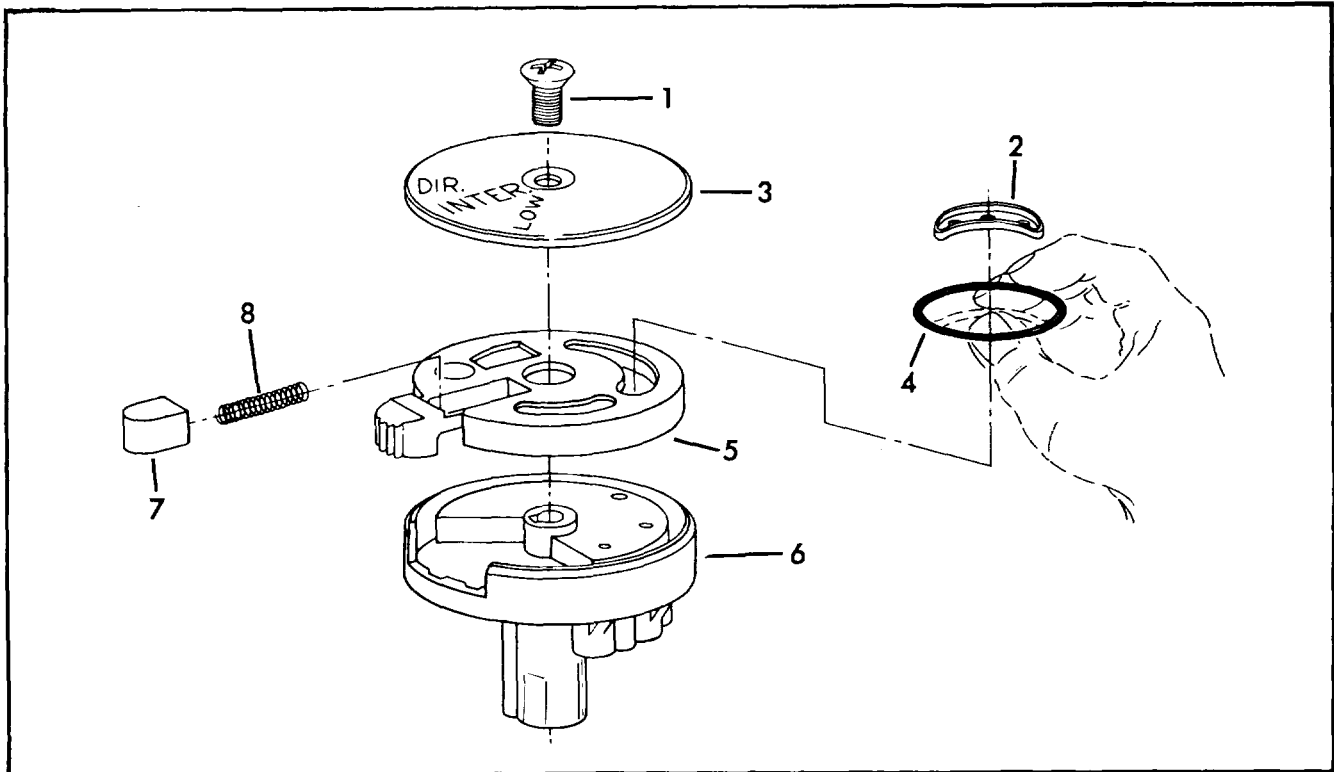

- | | |
|--------------------|-----------------------|
| 1. Top Plate Screw | 5. Control Lever |
| 2. Actuator | 6. Control Valve Body |
| 3. Plate | 7. Position Lock |
| 4. O-Ring | 8. Spring |

Illustration 4-30. Range Control Valve Disassembly.

1. With the range control in "LOW" position, disconnect the two lines connected to port "R" and "F". There should be no air coming out of these ports.
2. Move the range control to "INTER". There should now be a steady flow of air coming from the "F" port, but still no air coming from the "R" port.
3. Move the range control valve to the "DIR", position. There should now be a steady flow of air coming from both the "F" and "R" ports.
4. If the above results are not obtained, disconnect the supply air line at the "S" port and make sure that a steady flow of air is coming through the line. If air is present, this would indicate a faulty control valve. Cause can be defective parts, damaged O-ring or loose top plate screw.
5. Any steady flow of air from the range control valve exhaust port indicates a faulty range control valve or incorrect hook-up. Cause can be damaged O-ring, defective parts, loose top plate screw or reversed air lines on the control.

Air Valve and Filter Assembly.

MAINTENANCE (Illus. 4-31).

The air regulator is not serviceable. If defective replace. Reading at output of air regulator should be 57 to 62 psi.

Disassemble air filter in accordance with index numbers (B). Reassembly is the reverse of disassembly.

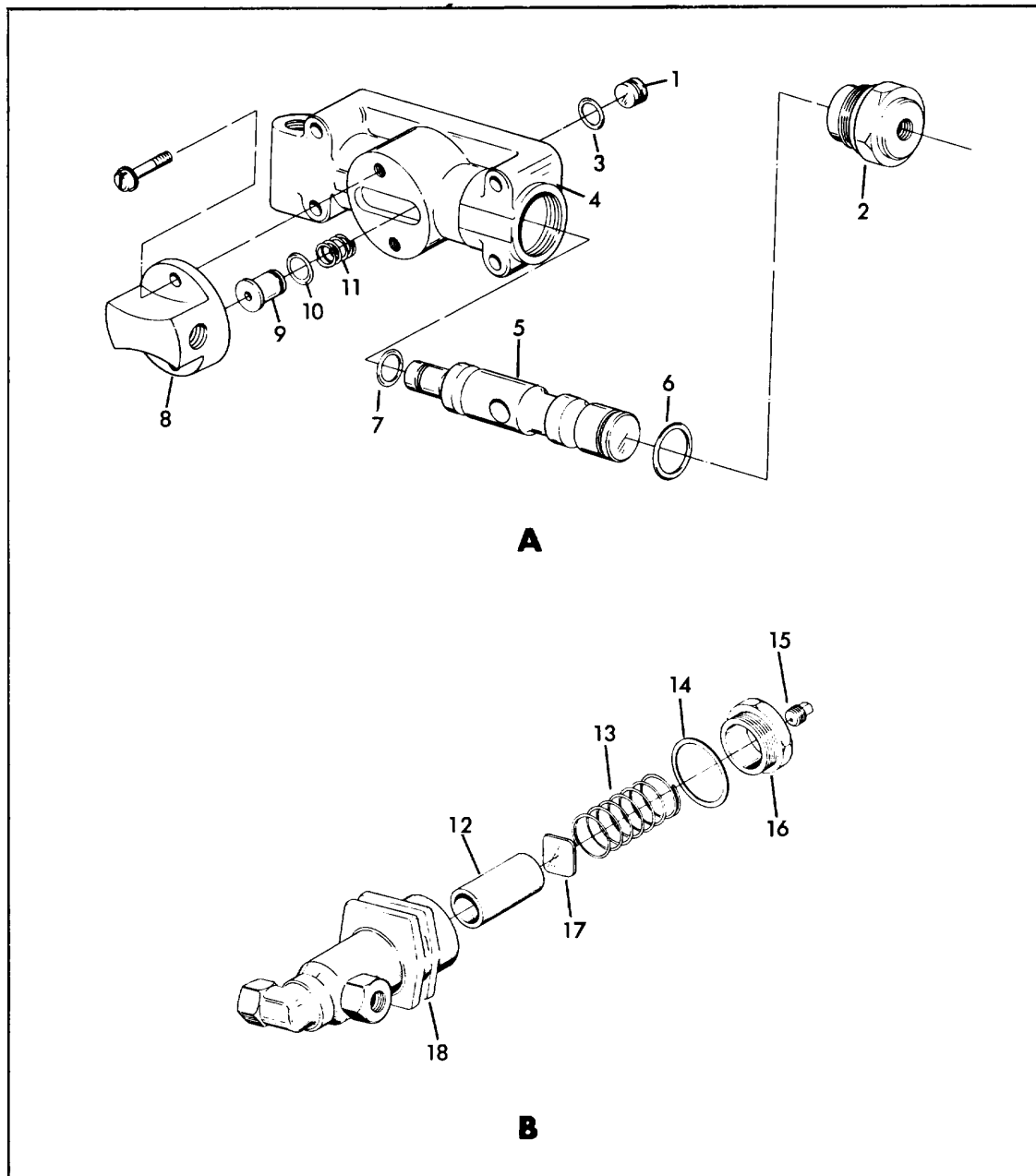

- | | | | |
|------------|-------------------|-------------------|---------------|
| 2. End Cap | A. Air Valve | 8. Side Cap | B. Air Filter |
| 3. O-Ring | 9. Valve Insert | 9. Valve Insert | 13. Spring |
| 4. Housing | 10. O-Ring | 10. O-Ring | 14. Gasket |
| 5. Piston | 11. Insert Spring | 11. Insert Spring | 15. Plug |
| 6. O-Ring | | | 16. End Cap |
| | | | 17. Plate |

Illustration 4-31. Air Valve and Air Filter Assembly.

Slave Air Valve.

REMOVAL.(Illus. 4-8).

Refer to Transmission Disassembly for Slave Air Valve Removal.

DISASSEMBLY. (Illus. 4-31).

1. Turn out the two capscrews and remove the side cap from valve body.
2. Remove the valve insert from piston and remove O-ring from the valve inlet.
3. Remove the spring from piston.
4. Turn end cap from valve body, and withdraw piston from bore.
5. Remove the two-rings from piston.
6. Remove the nylon plug from piston, and remove O-ring from plug.

REASSEMBLY.

Reassembly is the reverse of disassembly. Therefore no procedures are given. Replace all O-ring seals.

INSTALLATION.

Installation is the reverse of removal. Therefore no installation procedures are given.

TRANSMISSION TROUBLESHOOTING.

Listed below are troubles that may occur.

TRANSMISSION TROUBLESHOOTING

TROUBLE	PROBABLE CAUSE	REMEDY
Excessive lever travel or sloppy feel when shifting	Set screws loose in control shaft universal joints or shift fingers.	Tighten or replace set screws.
Hard shifting	Bent shift bar in transmission Damaged cross shaft or bushings in master or slave unit.	Disassemble and repair as necessary.
Transmission locked in gear or in neutral; gearshift lever moves freely; no detent feel.	Shift control shaft broken. U-joints loose or disconnected, cross shaft in slave unit broken or shift fingers loose.	Disassemble and repair as required.
Gearshift lever positions do not correspond to transmission gear ranges	Lever in master unit and cross shaft in slave unit out of phase.	Shift transmission to neutral. Disconnect U joints at shift control slave unit; place gearshift lever in neutral

TRANSMISSION TROUBLESHOOTING

TROUBLE	PROBABLE CAUSE	REMEDY
		position. Connect U-joints and tighten set screws.
Noise (from other sources)	<p>Fan bent or out of balance Damaged vibration damper Crankshaft out of balance</p> <p>Flywheel out of balance</p> <p>Unbalanced clutch assembly</p> <p>Loose engine mountings Worn universal joints</p> <p>Sprung driveshaft</p>	<p>Replace fan. Replace damper. Check balance. Replace crankshaft if necessary.</p> <p>Check balance. Replace flywheel if necessary.</p> <p>Check clutch and clutch housing for proper alignment.</p> <p>Tighten mountings. Replace universal joints.</p> <p>Replace driveshaft.</p>
Noisy transmission (in neutral)	<p>Transmission misaligned</p> <p>Worn transmission pinion bearing.</p> <p>Worn or scored countershaft bearings.</p> <p>Damaged second speed mainshaft gear bushing.</p> <p>Unmatched gears.</p> <p>Worn or rough reverse-idler gear.</p> <p>Eccentric countershaft gear assembly.</p> <p>Sprung or worn countershaft.</p> <p>Excessive backlash in gears.</p> <p>Excessive end play in countershaft, reverse-idler pinion.</p> <p>Worn mainshaft pilot bearing.</p> <p>Scuffed gear tooth contact surface.</p> <p>Insufficient lubrication.</p>	<p>Align engine and transmission (assembled) with rear axle so as to correct angles of universal joints.</p> <p>Replace bearing.</p> <p>Replace bearings.</p> <p>Replace bushing.</p> <p>Replace unmatched gears.</p> <p>Replace gear.</p> <p>Replace gear.</p> <p>Replace countershaft. Replace worn gears. Adjust to reduce end play.</p> <p>Replace pilot bearing. Replace gear.</p> <p>Check for leaks; fill to proper level.</p>

TRANSMISSION TROUBLESHOOTING

TROUBLE	PROBABLE CAUSE	REMEDY
Noisy transmission (in gear)	Gears worn and pitted due to lugging engine with transmission in too high a gear range. Bearings worn due to lugging engine with transmission in too high a gear range, or to chips and dirt in oil. Worn, chipped or tapered sliding gear teeth. Noisy speedometer gears Transmission not lined up properly with chassis	Replace gears. Replace worn or rough bearings. Replace gears. Replace gears. Line up transmission with rear axle so as to correct angles of universal joints.
Difficult shifting	Improperly operating clutch Sliding gear tight on shaft splines Burred mainshaft splines Improper adjustment of shifting linkage Worn or bent shifter rails Insufficient lubricant	Adjust clutch. Check alignment. Check for galling. Replace as necessary. Replace mainshaft. Check and adjust linkage and rods to make sure transmission is shifting full into gear. Replace worn or bent shifter rails. Fill to proper level.
Range shift inoperative or malfunctioning. valve on shift lever and air	Air line crossed between control valve on transmission (steady leakage from exhaust port on range shift control valve, with button in the UP position). Lines crossed between air valve on transmission and the shift cylinder. Low range (DOWN position) of button results in high range gear engagement, and vice versa. Range shift control valve leaking due to poor o-ring seals ring seals. Leakage from exhaust port of regulator due to ruptured diaphragm or clogged regulator piston.	Disconnect crossed air lines and correct hook-up. Disconnect crossed air lines and correct hook-up. Disassemble control valve and replace o- Disassemble, clean and repair regulator.

TRANSMISSION TROUBLESHOOTING

TROUBLE	PROBABLE CAUSE	REMEDY
Sticking in gear	Clutch operating improperly	Adjust clutch. Check alignment.
Jumping out of gear	Sliding gear tight on mainshaft splines	Check for galling. Replace as necessary.
	Improper adjustment of linkage	Adjust linkage.
	Misaligned transmission	Check alignment.
	Shift rail poppet springs broken.	Replace poppet springs.
Oil leakage	Shift rail poppet notch worn	Replace shift rail.
	Shift forks sprung or loose on shift rail	Replace sprung fork or tighten setscrew in shift fork.
	Linkage and rods between shift lever and auxiliary transmission not properly adjusted	Check and adjust linkage and rods to make sure transmission is shifting full into gear.
	Clutch gear teeth worn tapered	Replace worn parts.
	Bearings worn	Replace bearings.
	Transmission mounting in chassis puts strain on case.	
	Line up front mounting bracket so it does not cause strain on front mainshaft bearing retainer.	
	Transmission overfilled	Drain to proper level.
	Breather stopped up	Clean breather assembly.-
	Use of transmission oil that foams and expands when hot.	Drain and refill with high grade properly refined, straight run mineral oil.
Bearing failure lubricant	Drain back holes between bearing retainers and main case stopped up	Check drain holes and gaskets to make sure openings are clean.
	Broken gaskets	Replace gaskets and use gasket cement.
	Worn mainshaft bearings	Replace bearings.
	Loose drain plug in transmission.	Tighten drain plug.
	Cracked transmission housing	Replace transmission.
Bearing failure lubricant	Cover not properly tightened	Tighten cover.
	Use of wrong type or grade of lubricant	Drain transmission; flush and refill with proper grade and type of lubricant.

TRANSMISSION TROUBLESHOOTING

TROUBLE	PROBABLE CAUSE	REMEDY
Bearing failure (continued)	Bearings adjusted too tight or too loose Improper assembly of trans- mission Lack of cleanliness in overhaul of transmission resulting in damaged bearings due to foreign matter in oil.	Obtain correct adjust- ment. Disassemble the trans- mission. Determine improper assembly and reassemble correctly. Replace worn or damaged bearings. Properly clean transmission.

LUBRICATION.

The transmission is designed so that the internal parts operate in a bath of oil circulated by the motion of gears and shafts. Grey iron parts have built-in channels where needed, to help lubricate bearings and shafts.

Thus, all parts will be amply lubricated if these procedures are closely followed:

1. Maintain oil level. Inspect regularly.
2. Change oil regularly.
3. Use the correct grade and type of oil.
4. Buy from a reputable dealer.

To keep the gear oil clean between oil changes use the Fuller Transmission Gear Oil Filter which can be attached to the right-side power take-off opening. This assembly includes a replaceable filter element that removes the accumulation of metallic particles, road dirt and grit deposited in the lubricant.

RECOMMENDED LUBRICANTS.

Heavy-duty engine oil. Make sure to specify heavy-duty type meeting MIL-L-2104B specifications.

Mineral gear oil inhibited against rust, oxidation and foaming.

Extreme pressure oils under some conditions might form carbon deposits on gears, shafts, bearings and synchronizer discs, and may also glaze friction surfaces of synchronizer discs conditions which will result in transmission malfunction and premature failure. It is suggested that if these conditions exist, and E.P. oil is being used, a change should be made to straight mineral gear oil or heavy duty engine as recommended.

	ON-HIGHWAY VEHICLES	
TYPE	GRADE	TEMPERATURE
Heavy Duty Engine Oil	SAE 50	Above +10 F.
MIL-L-2104B	SAE 30	Below +10 F.
Mineral Gear Oil	SAE 90	Above +10 F.
R and O Type	SAE 80	Below +10 F.
Mild E.P. Oil (except Sulfur-chlorine-lead type) MIL-L-2105B	SAE90	Above +10 F.
	SAE80	Below +10 F.
	OFF-HIGHWAY AND MINING EQUIPMENT	
Heavy Duty Engine Oil	SAE 50	Above +10 F.
MIL-L-2104B	SAE 30	Below +10 F.
Special Recommendation - For extreme cold weather where temperature is consistently below 0 F.		
Heavy Duty Engine Oil	SAE 20W	Below 0 F.
MIL-L-2104B		

To drain the transmission remove the two drain plugs One at the bottom of the front case and one at the bottom the intermediate case. Drain oil when transmission is war After the transmission has been drained and before it is l filled, the case should be thoroughly flushed with a clean flushing oil or kerosene. Do not use flushing compound unit is equipped with side or front mounted pressure lubrication pumps unless pump is removed and opening covered with plate. Clean both drain plugs before reinstalling.

In order to assure complete filling of the transmission with 16 pints of oil, the following two methods may be use:

- 1) At any inclination: Plug both fill holes (one in t front case and one in the intermediate case) and add entire 16-pint quantity through opening in shift bar housing. T transmission must be *completely drained* before using this method in order to avoid overfilling.
- 2) At upgrade inclinations from 0 through 3 degrees: A sufficient quantities through both fill holes to level the at the bottom of both fill holes.

Do not overfill. Overfilling will cause the oil to be force out of the case through the mainshaft openings.

It is recommended that types and brands of oil not intermixed because of possible incompatibility.

Additions of oil during servicing operations should made through both fill holes to level the oil at the bottom both fill holes with the transmission at a 0 to 3 Degree u grade angle.

It is imperative that the operating temperature of t transmission does not exceed 250°F.

Extensive operation at temperatures exceeding 2500 will result in rapid breakdown of the oil and shorten transmission life.

Transmissions used in stationary equipment, or in hides operating at slow road speeds, may have to be equipped with external coolers so that the 2500F. temperature is not exceeded.

Gear oil is to be kept even with the level of the filler opening at all times. Check at the following intervals:

- Highway Service 1,000 miles
- Off-highway Service..... 40 hours

Change the gear oil on all new equipment after the first 3000 to 5000 miles (on-highway), or first 40 hours (off-highway): thereafter, make oil changes as follows:

- Highway Service 25,000 miles
- Off-highway Service
 - Logging and associated operations 1,000 hours
 - Dirt moving, mining and associated operations 250 to 500 hours, as indicated by operation and contamination of lubricant.

The above oil inspection and change periods are based on the average use and operating conditions for the applications listed. It is recommended that the individual owner make a periodic lab analysis of the lubricant to determine contamination based on the individual's own operating conditions. After this has been determined, the individual owner can then set his own inspection and oil change periods.

Lubricate the clutch release bearing after each 40 hours of operation with Mobil grease No. 5 or its equivalent.

If so equipped, replace filter element at each oil change; clean filter element housing.

PREVENTIVE MAINTENANCE.

1. Air System and Connections

- a. Check for leaks, worn air lines, loose connections and capscrews. See Air Systems.

2. Clutch Housing Mounting

- a. Check all capscrews in bolt circle of clutch housing for looseness.

3. Clutch Release Bearing

- a. Remove hand hole cover and check radial and axial clearances in release bearing.
- b. Check relative position of thrust surface of release bearing with thrust sleeve on push type clutches.

4. Clutch Pedal Shaft and Bores

- a. Pry upward on shafts to check wear.
- b. If excessive movement is found, remove clutch release mechanism and check bushings in bores and wear on shafts.

5. Gear Lubricant

- a. Change at specified service intervals.
- b. Use only gear oils as recommended. See Lubrication section.

6. Filler and Drain Plugs

- a. Remove filter plugs and check level of lubricant at specified intervals. Tighten filler and drain plugs securely.

7. Gear Shift Lever

- a. Check for looseness and free play in housing. If lever is loose in housing, proceed with Check No. 8.

8. Gear Shift Lever Housing Assembly

- a. Remove air lines at air valve and remove the gear shift lever housing assembly from transmission.
- b. Check tension spring and washer for set and wear.
- c. Check the gear shift lever pivot pin and pivot pin slot for wear.
- d. Check bottom end of gear shift lever for wear and check slot of yokes and blocks in shift bar housing for wear at contact points with shift lever.
- e. If so equipped, check O-ring in housing for wear or cracks.

CHECKS WITH DRIVE LINE DROPPED

- 9. Universal Joint Companion Flange Nut**
 a. Check for tightness. Tighten to recommended torque.

CHECKS WITH UNIVERSAL JOINT COMPANION FLANGE REMOVED

- 10. Output Shaft**
 a. Check splines for wear from movement and chucking action of the universal joint companion flange.
 b. Pry upward against output shaft to check radial clearance in mainshaft rear bearing.
- 11. Mainshaft Rear Bearing Cover**
 a. Check oil seal for wear.

INSPECTION.

Before reassembling the transmission, the individual parts should be carefully checked to eliminate those damaged from previous service. This inspection procedure should be carefully followed to insure the maximum of wear life from the rebuilt unit.

The cost of a new part is generally a small fraction of the total cost of downtime and labor, should the use of a questionable part make additional repairs necessary before the next regularly scheduled overhaul.

Recommended inspection procedures are set forth in the following check list:

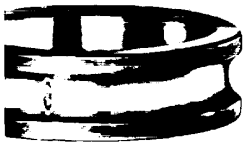
**1. Bearings**

- A.** Wash all bearings in clean solvent. Check balls, rolls and races for pits and spalled areas. Replace bearings which are pitted or spalled.
- B.** Lubricate bearings which are not spalled or pitted and check for axial and radial clearances. Replace bearings with excessive clearances.
- C.** Check fits of bearings in case bores. If outer races turn freely in the bores, the case should be replaced.

2. Gears

- A. Check operating gear teeth for pitting on the tooth faces. Gears with pitted teeth should be replaced.
- B. Check all engaging gear teeth. Gears with teeth worn, tapered or reduced in length from clashing in shifting should be replaced.
- C. Check axial clearances of gears. Where excessive clearance is found, check gear snap ring, washer, spacer and gear hub for excessive wear. Maintain .005 to .011 axial clearance of mainshaft forward speed gears, .011 to .032 on reverse gear.

3. Splines

- A. Check splines on all shafts for wear. If sliding clutch gears, companion flange or clutch hub have worn into the sides of the splines, the shafts in this condition should be replaced.

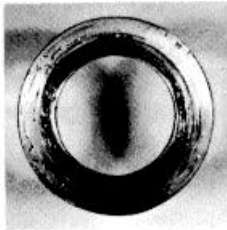

4. Thrust Washers

- A. Check surfaces of all thrust washers. Washers scored or reduced in thickness should be replaced.

5. Reverse Gear and Shaft

- A. Check bearing sleeve for wear from action of roller bearings.

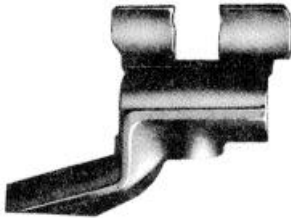
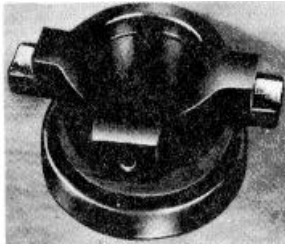
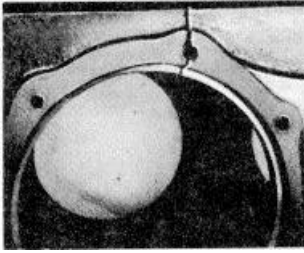

6. Gray Iron Parts

- A. Check all gray iron parts for cracks and breaks. Replace or repair parts found to be damaged. Heavy castings may be welded or brazed providing the cracks do not extend into bearing bores or bolting surfaces.

7. Clutch Release Parts

- A. Check clutch release parts. Replace yokes worn at cam surfaces and bearing carrier worn at contact pads.
- B. Check pedal shafts. Replace those worn at bearing surfaces.

8. Shifting Bar Housing Assembly

- A. Check yokes and blocks for wear at pads and lever slot. Replace worn parts.
- B. Check yokes for alignment. Straighten those which are sprung.
- C. Check yokes for excessive wear; replace worn yokes.
- D. Check lock screws in yokes and blocks. Tighten and rewire those found loose.
- E. If housing has been dismantled, check neutral notches of shifting bars for wear from interlock balls. Bars indented at points adjacent to the neutral notch should be replaced.

9. Gear Shift Lever Housing Assembly

- A. Check spring tension on shift lever. Replace tension spring and washer if lever moves too freely.
- B. If housing is dismantled, check pivot pin and corresponding slot in lever for wear. Replace both parts if worn. If so equipped, check O-ring in housing for wear or cracks.

10. Bearing Covers

- A. Check covers for wear from thrust of adjacent bearing. Replace covers worn and grooved from thrust of bearing outer race.
- B. Check bores of covers for wear. Replace those worn oversize.

11. Oil Return Threads and Seals

- A. Check oil return threads in front bearing cover. If sealing action of threads has been destroyed by contact with input shaft, replace the cover.
- B. Check oil seal in mainshaft rear bearing cover. If sealing action of lip has been destroyed, replace seal.

12. Synchronizers

- A. Check high and low range synchronizers for burrs, uneven and excessive wear at contact surface.
- B. Check blocker pins for excessive wear or looseness.
- C. Check synchronizer contact surfaces on the high and low range gears for excessive wear.

13. Sliding Clutches

- A. Check all yokes and yoke slots in sliding clutches for extreme wear or discoloration from heat.
- B. Check engaging teeth of sliding clutches for partial engagement pattern.

Transmission.

DISASSEMBLY.

It is assumed in the detailed disassembly instructions that the lubricant has been drained from the transmission, the necessary linkage and air lines removed and the transmission has been removed from the chassis. Removal of the gear shift lever housing assembly is included in the detailed instructions; however, this assembly must also be removed from transmission before removing unit from vehicle.

Air lines from the range shift and splitter gear controls must be disconnected at the transmission before removing unit from vehicle.

Follow each procedure closely in each section, making use of both the text and pictures.

Carefully wash and relubricate all bearings as removed and protectively wrap until ready for use. Remove bearings with pullers designed for this purpose.

When disassembling the various assemblies, such as the mainshaft, countershafts and shifting bar housing, lay all parts on a clean bench in the same sequence as removed. This procedure will simplify reassembly and reduce the possibility of losing parts.

Remove snap rings with pliers designed for this purpose. Rings removed in this manner can be reused.

The clutch or input shaft can be removed without removing the countershafts, mainshaft or drive gear.

Provide a clean place to work. It is important that no dirt or foreign material enters the unit during repairs. The outside of the unit should be carefully cleaned before starting the disassembly. Dirt is abrasive and can damage bearings.

Apply force to shafts, housings, etc., with restraint. Movement of some parts is restricted. Do not apply force after the part being driven stops solidly. Use soft hammers and bars for all disassembly work.



Bearing removed with chisel, damaged outer race.



Bearing removed with punch, damaged shield.

4-113

1. Disassemble Shifting Controls.



Disconnect the 1/2 " OD air line at the tee block fitting between the air filter and regulator.

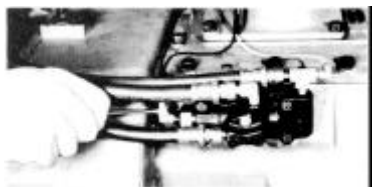

Disconnect the 1/8 " OD range shift control air line at the rear port of the slave air valve.

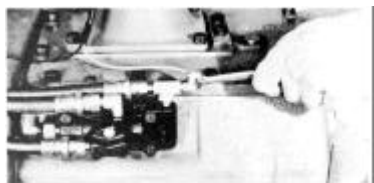

Disconnect the 1/8" OD range shift air line at the forward port of the slave air valve.

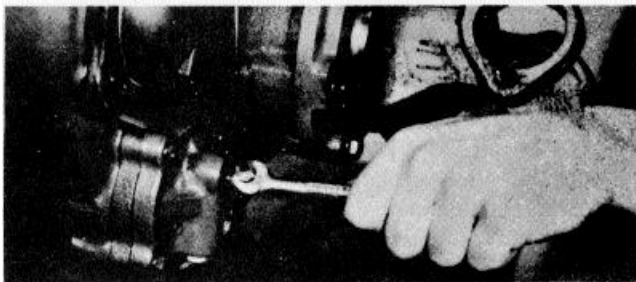

Disconnect the 1/8" OD range shift control air line at the intermediate shift cylinder.

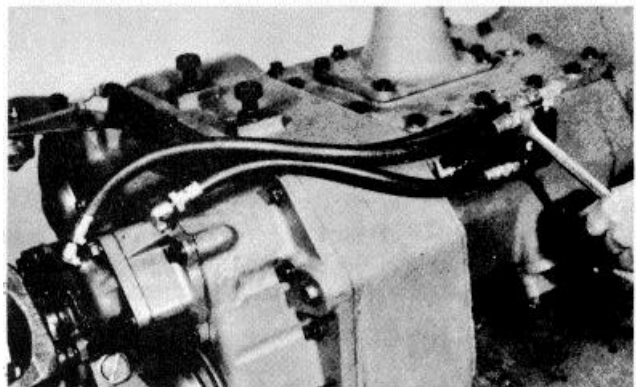

Remove the 1/4" ID air line between the air valve and the direct range port of the auxiliary shift cylinder.

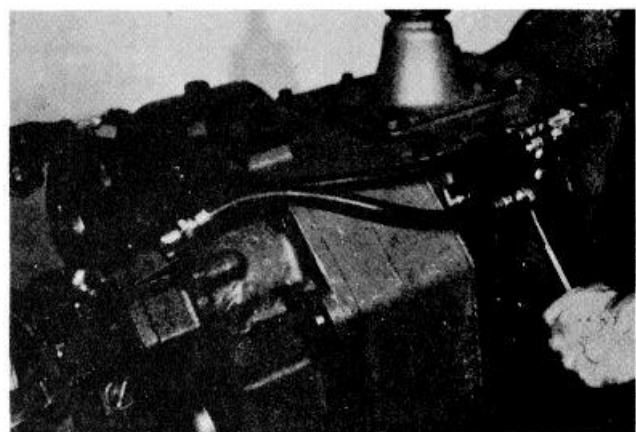

Remove the 1/4" ID air line between the air valve and the low range port of the auxiliary shift cylinder.

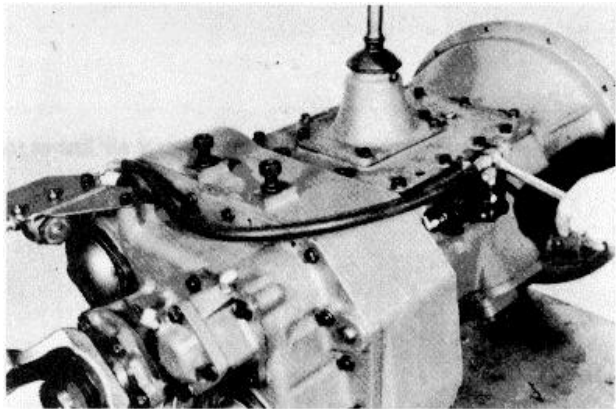

Remove the 1/4" ID air line between the air valve and the air filter/regulator assembly. If so equipped, the hose-retaining clamp will have to be removed to allow removal of the air line.

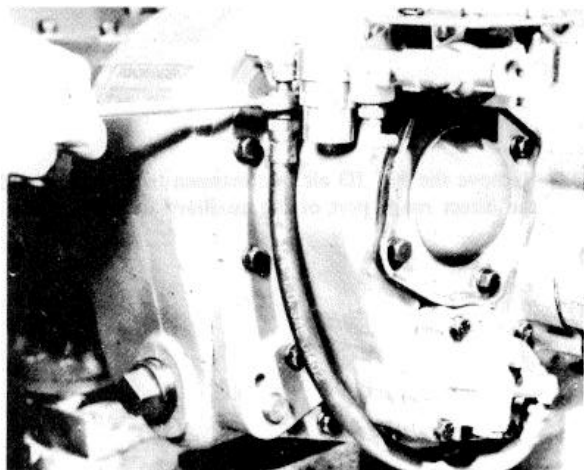

Remove the 1/4" ID air line between the air filter/regulator assembly and the intermediate shift cylinder.

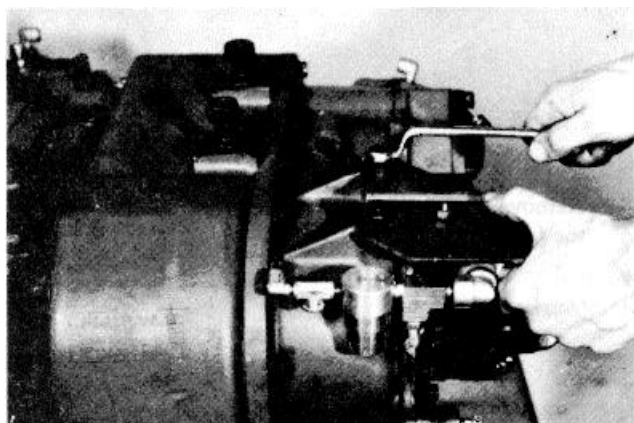

Turn out the two capscrews and remove the air filter/regulator assembly.

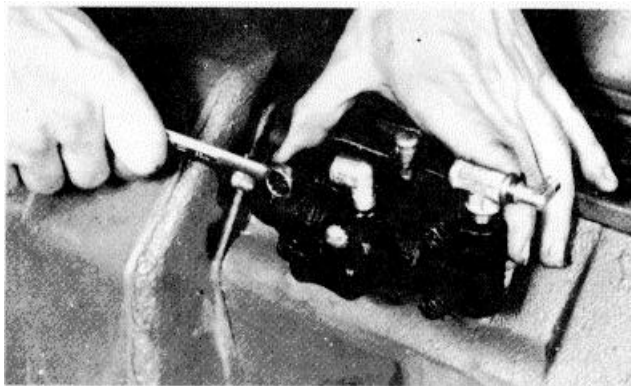

Turn out the four retaining capscrews and remove the slave air valve from the transmission.



Remove the hat-type sleeve from the bore in the valve.



Remove the spring and plunger from the bore in the transmission.

2. Disassemble Gear Shift Housing Assembly.

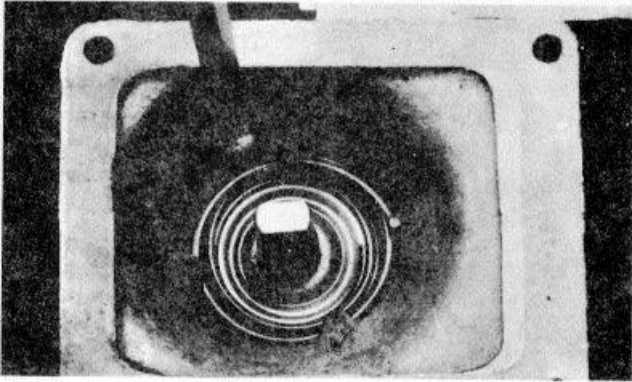

secure the assembly upside down in a vise and remove the tension spring by prying it up and over the spring retainers, one coil at a time.

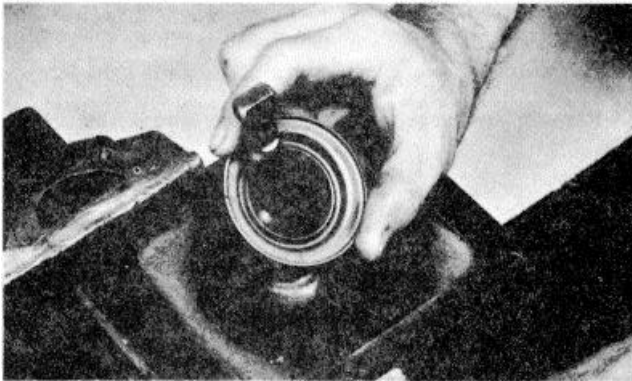

Remove the washer and lever from the housing.

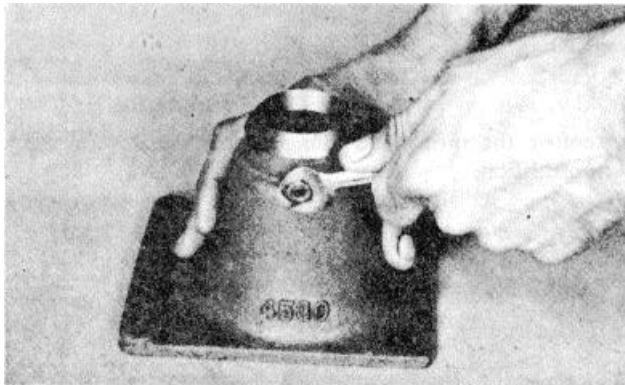

Remove the housing from the vise and, if necessary, remove the nut, washer, pivot pin, and O-Ring.

3. Disassemble Shift Bar Housing.

NOTE

SEE ILLUSTRATION 4-32 FOR EXPLODED VIEW OF THE SHAFT BAR.

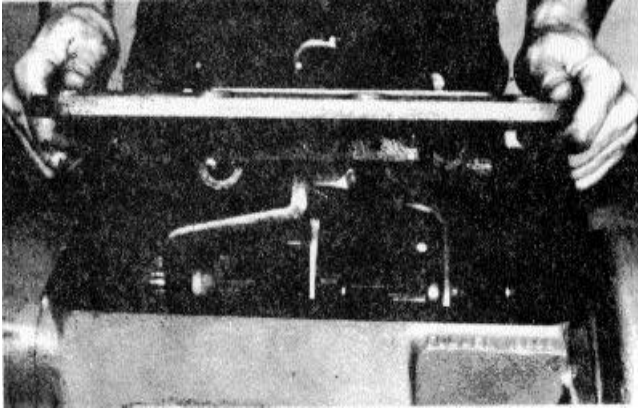

Turn out the 13 retaining capscrews, jar to break gasket seal, and remove the shift bar housing from the transmission.

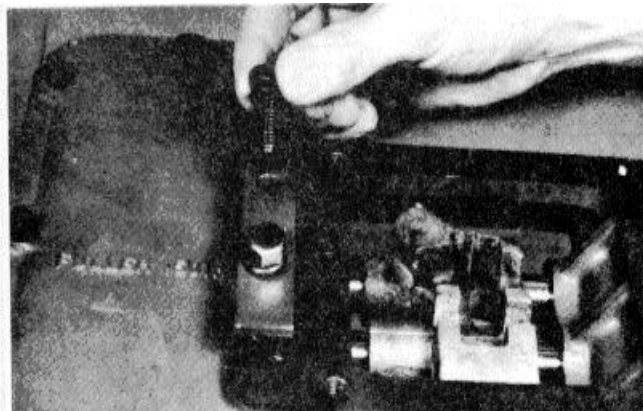

Turn out the two cap screws and remove the tension spring cover.



Remove the three tension springs.

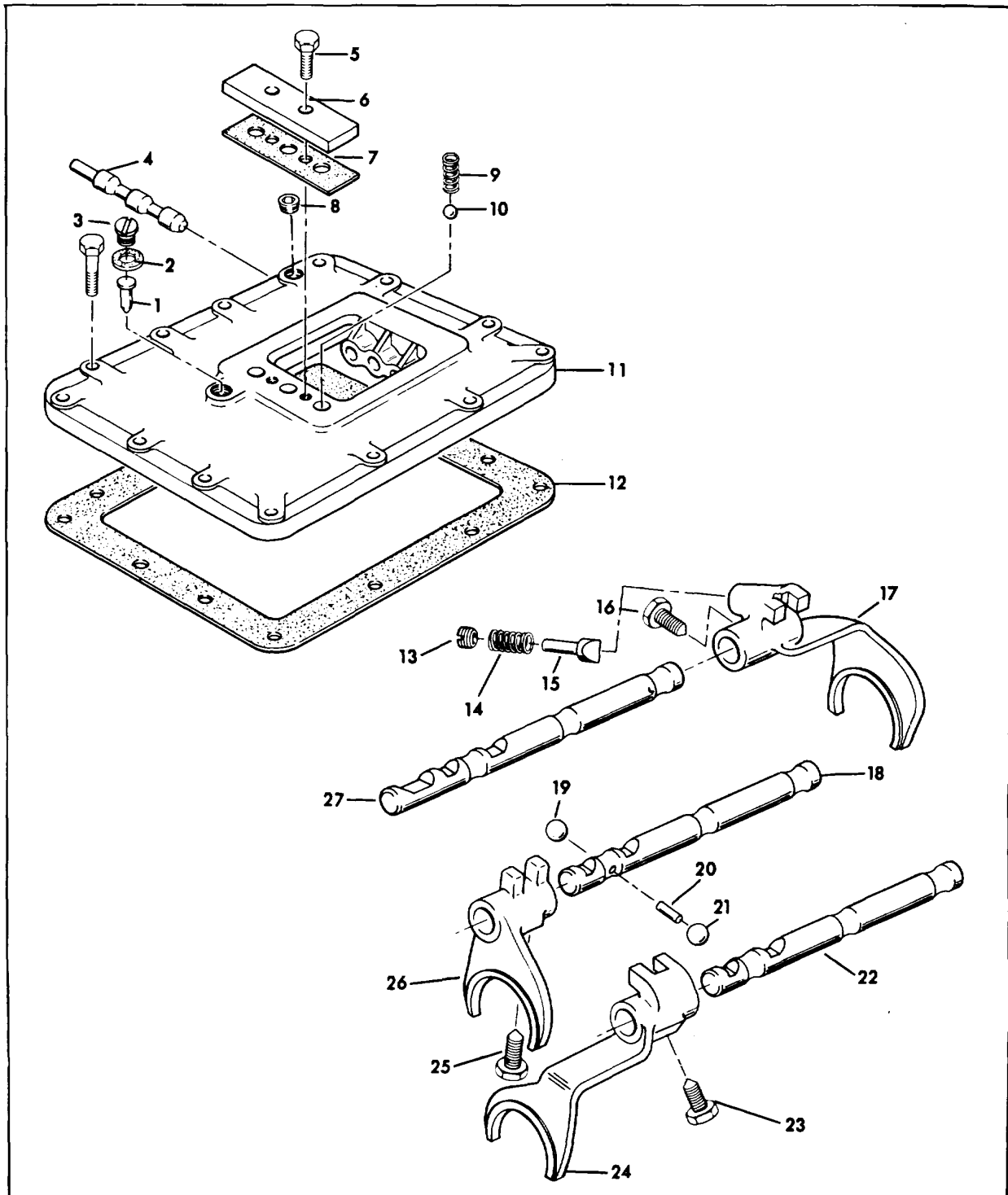

- | | | | |
|--------------------------|-----------------------|--|---|
| 1. Pin | 8. Plug | 15. Plunger | 22. 4 th -5 th Speed Shift Bar |
| 2. Gasket | 9. Tension Spring | 16. Lockscrew | 23. Lockscrew |
| 3. Actuating Plunger | 10. Tension Ball | 17. 1 st -Reverse Shift Yoke | 24. 4 th -5 th Speed Shift Yoke |
| 4. Actuating Plunger | 11. Shift Bar Housing | 18. 2 nd -3 rd Speed Shift Bar | 25. Lockscrew |
| 5. Capscrew (2) | 12. Gasket | 19. Interlock Ball | 26. 2 nd -3 rd Speed Shift Yoke |
| 6. Tension S[pring Cover | 13. Plug | 20. Interlock Pin | 27. 1 st -Reverse Shift Bar |
| 7. Gasket | 14. Spring | 21. Interlock Ball | |

Illustration 4-32. Shift Bar Housing.

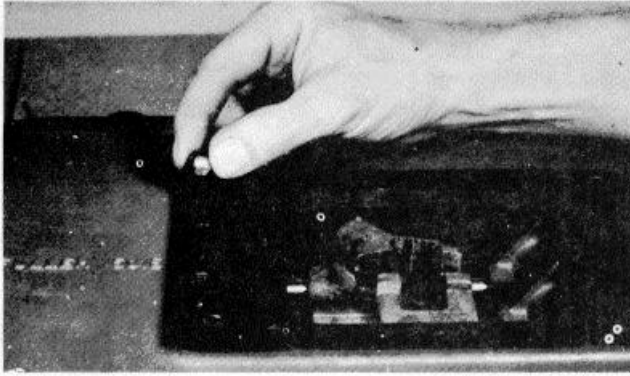

Remove the three tension balls located tender the springs.

NOTE:

For ease of reassembly, lay all parts on a clean bench in order of removal. Bars not being removed must be kept in the neutral position or interlock parts will lock the bars.

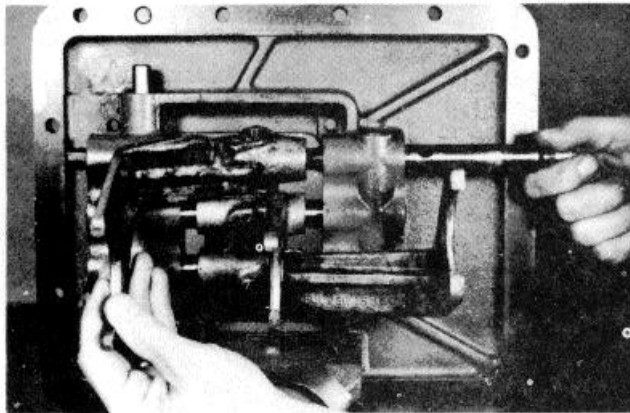

Place the shift bar housing in a vise, cut the lockwire, turn out the lockscrew and pull the 1st-reverse shift bar from the housing, removing the yoke.

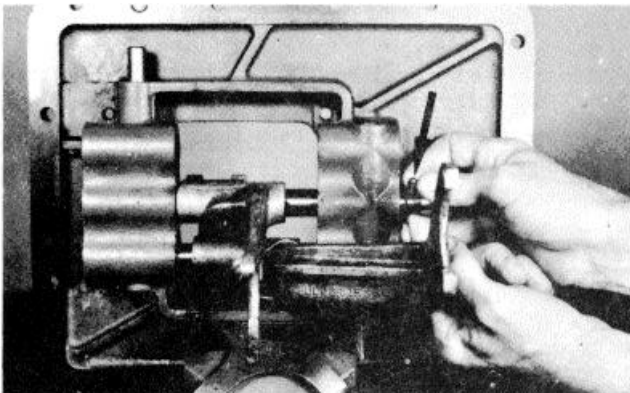

Cut the lockwire, turn out the lockscrew and pull the 2nd-3rd speed shift bar from the housing, removing the interlock pin from the neutral notch; remove yoke.

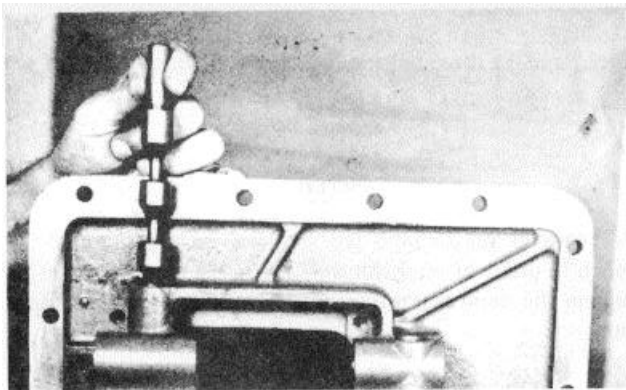

Remove the actuating plunger from the housing.

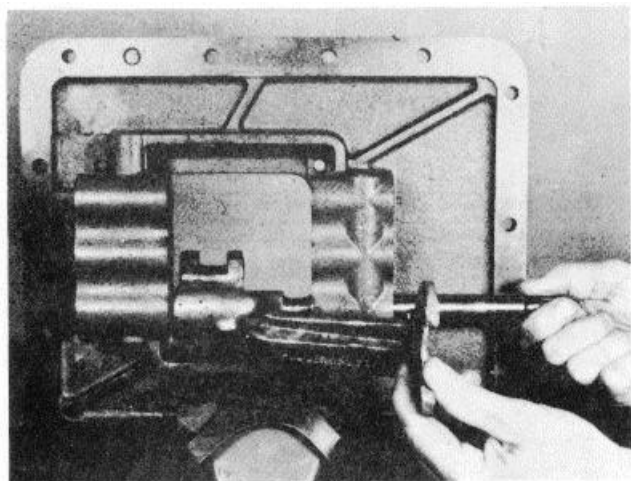

Cut the lockwire, turn out the lock screw and pull the 4th-5th speed bar from the housing, removing the yoke.

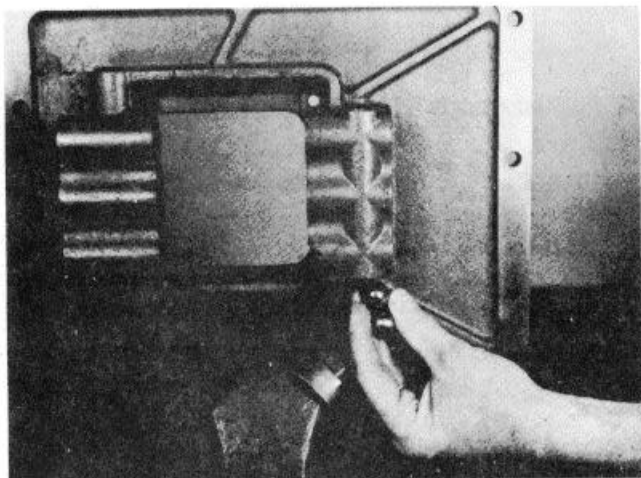

Remove the two interlock balls from the web of the housing.

4. Disassemble Companion Flange and Clutch Housing.

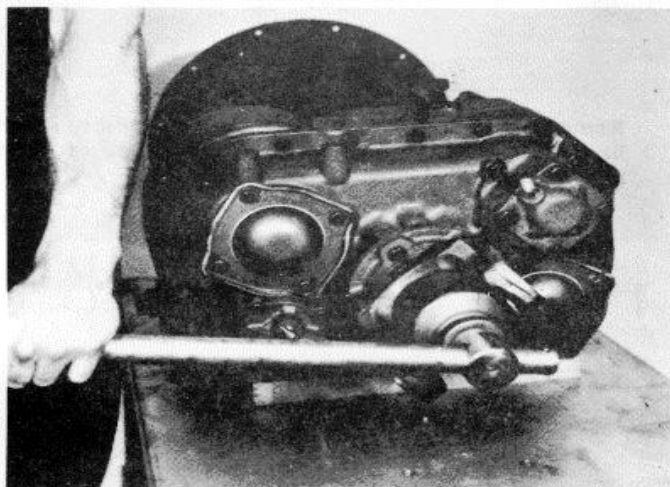

Lock the transmission in two speeds and turn the nut from the tailshaft.

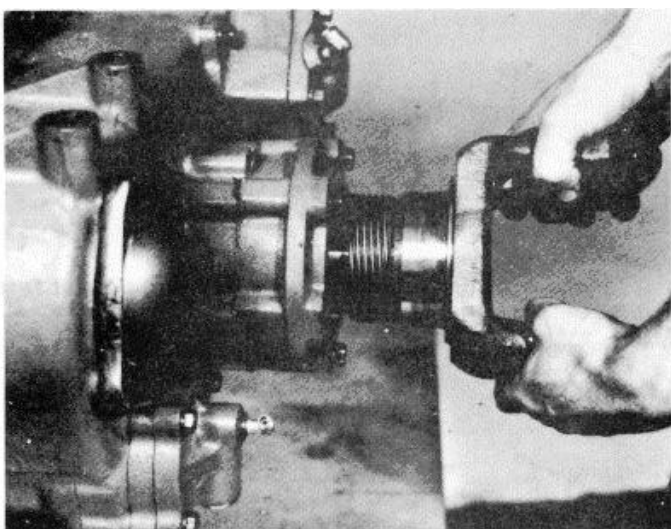

Pull the companion flange or yoke from the splines of the tailshaft.

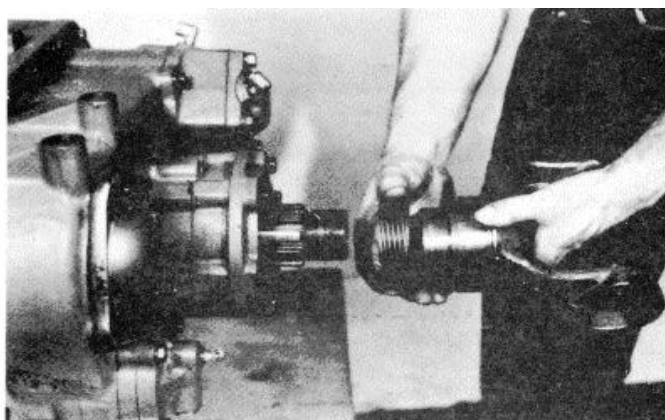

Remove the speedometer drive gear or replacement spacer from the companion flange or yoke.

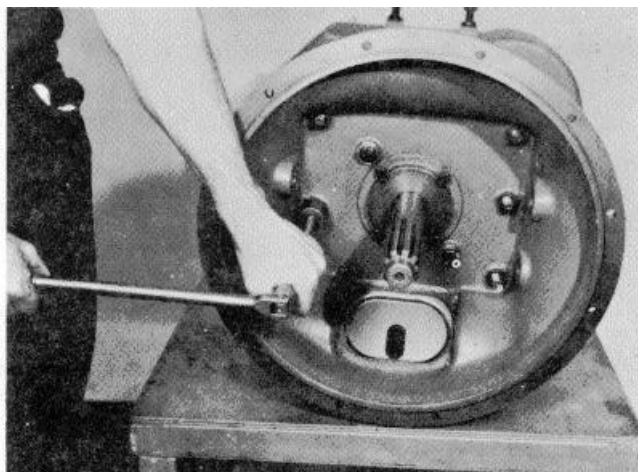

Remove the clutch release mechanism or upshift clutch brake assembly and turn out the six nuts and two bolts which attach the clutch housing to the case.

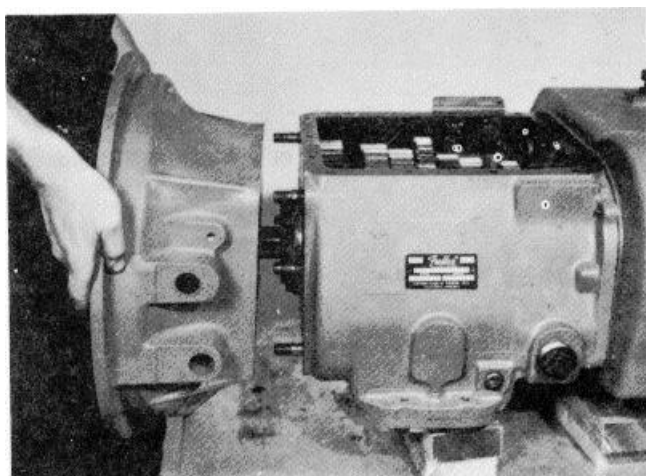

Jar the housing to break the gasket seal and pull from the studs and transmission case.

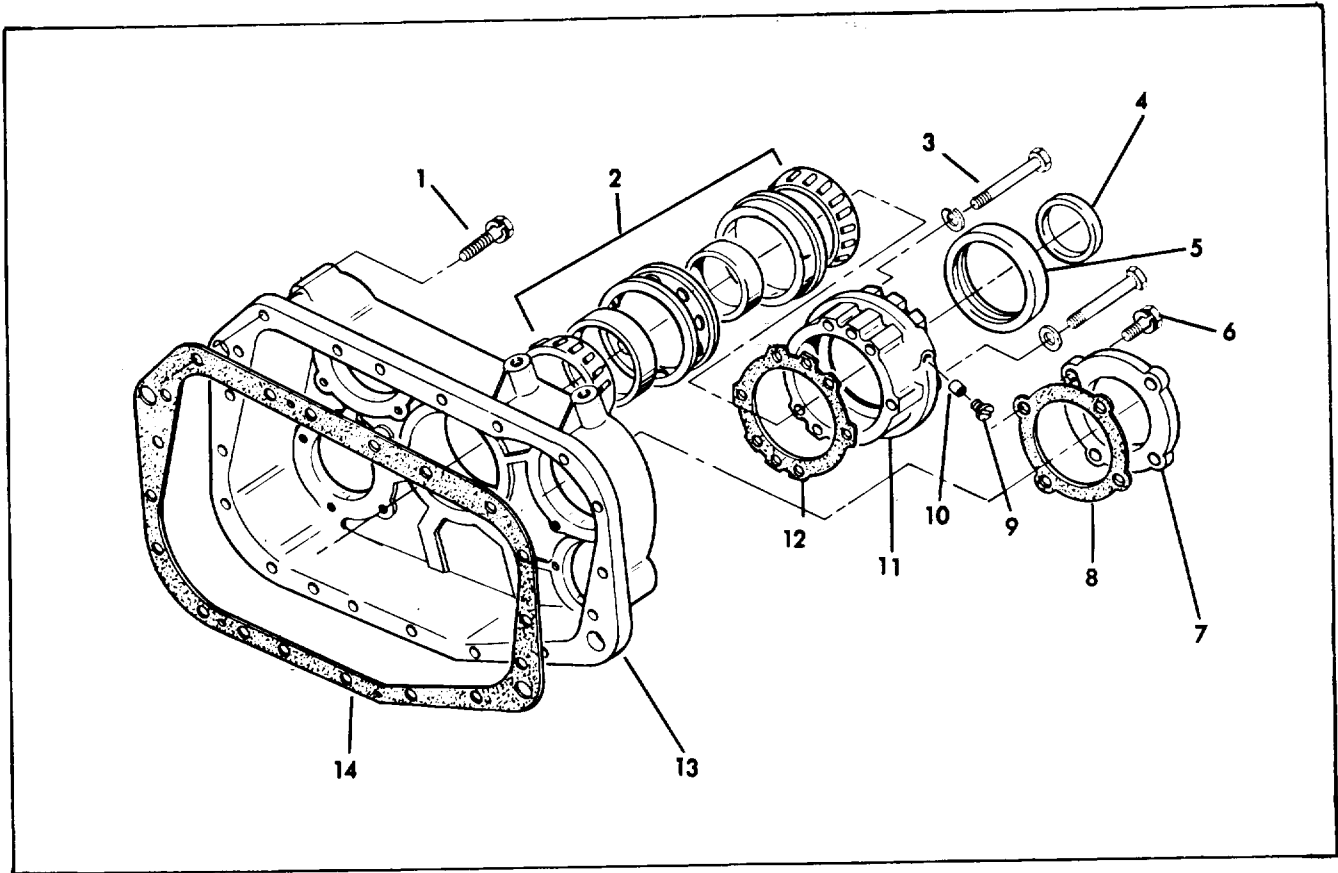

- | | |
|--|----------------------------|
| 1. Capscrew (19) | 8. Gasket (2) |
| 2. Rear Bearing Assembly | 9. Plug |
| 3. Capscrew (4) | 10. Bushing |
| 4. Speedo Replacement Spacer | 11. Rear Bearing Housing |
| 5. Oil Seal | 12. Gasket |
| 6. Capscrews (8) | 13. Auxiliary Rear Housing |
| 7. Auxiliary Countershaft Rear Bearing Cover (2) | 14. Gasket |

Illustration 4-33. Auxiliary Rear Housing Assembly.

5. Disassemble of Rear Housing Assembly.

NOTE

SEE ILLUSTRATION 4-33 FOR EXPLODED VIEW-OF REAR HOUSING ASSEMBLY.

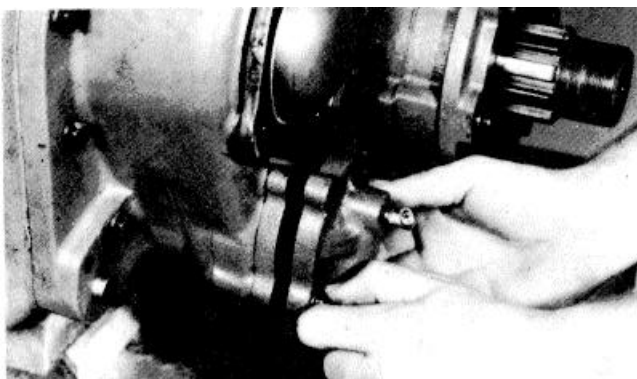

Turn out the four cap screws and remove the cover from the intermediate shift cylinder.

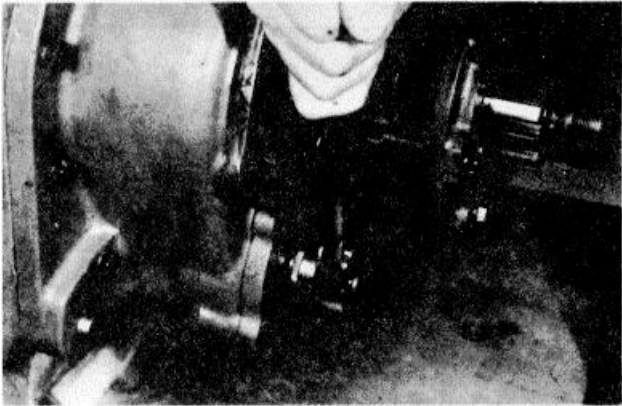

Remove the locknut from the shaft in the cylinder.



Pull evenly to the rear and remove the cylinder housing from the bore in the auxiliary housing.



Remove the piston from the cylinder housing and, if necessary, remove the O-ring from the outer diameter of the piston.

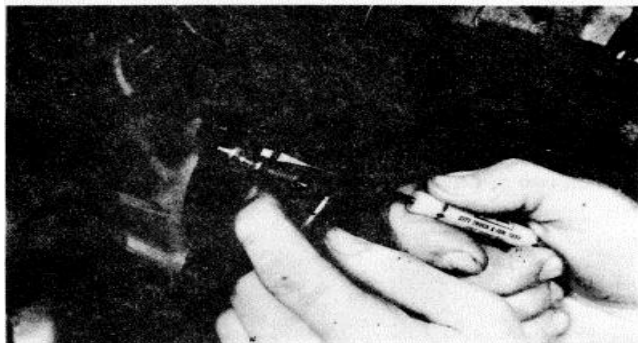

If necessary, remove the O-rings from the bore in the cylinder housing and the shaft.

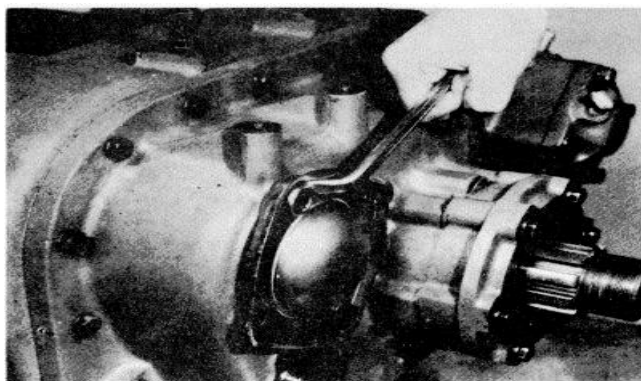

Turn out the capscrews and remove the two rear countershaft bearing covers.

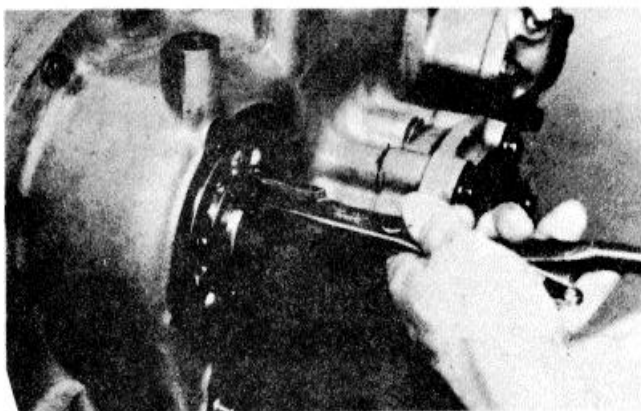

Remove the snap ring from the rear of both countershafts.

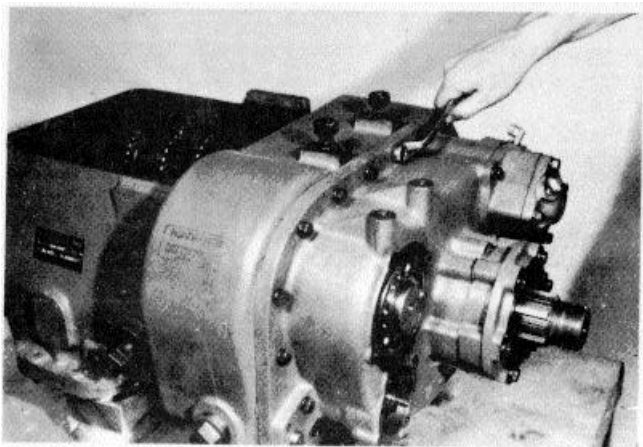

Turn out the 19 capscrews which attach the rear housing to the intermediate case. Re-insert one capscrew near both dowel pin locations and turn in just far enough to catch two or three threads.

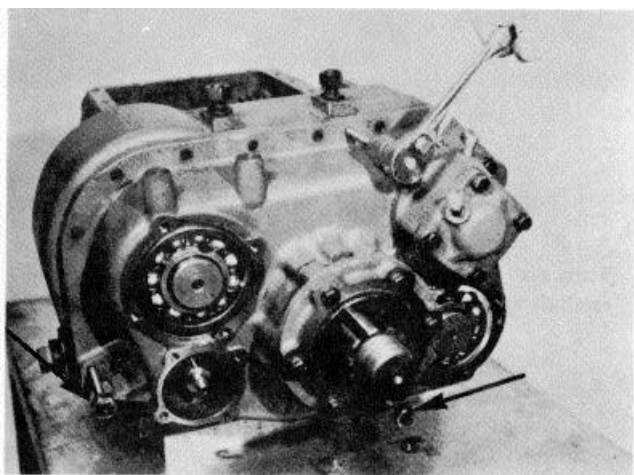

Insert three puller screws and move the rear housing approximately $\frac{1}{4}$ " to the rear.

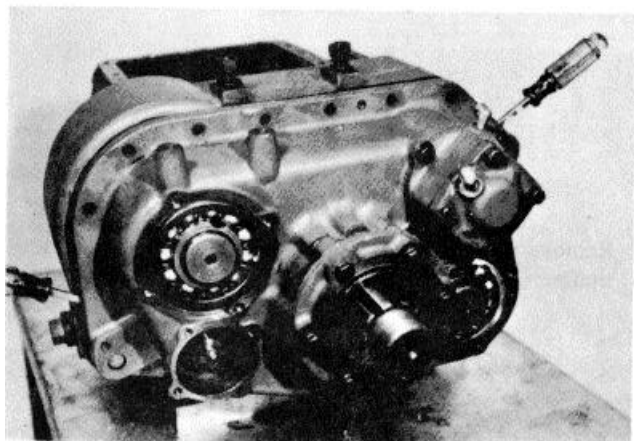

Insert flat stock, such as flat-bladed screwdrivers, between the auxiliary and intermediate housing.

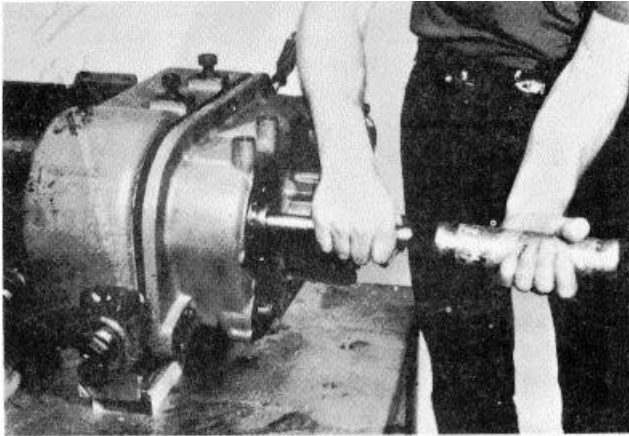

Use a soft bar and mallet against the rear of both counter shafts to move them as far forward as possible. This will move the bearings to the rear on the shafts.

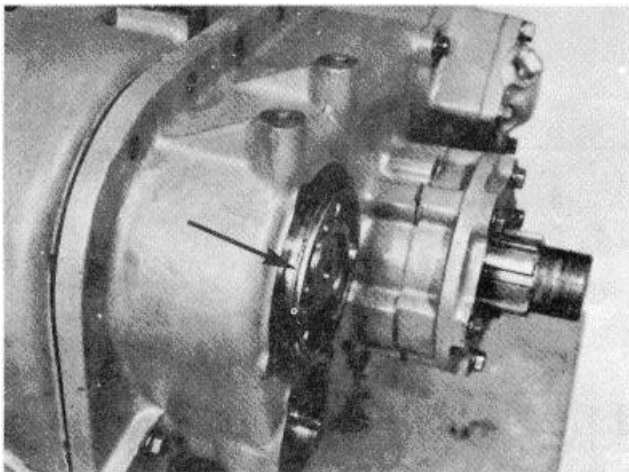

Remove the flat stock and puller screws. Move the rear housing to its original position against the intermediate housing by turning in evenly the two remaining cap screws. This will expose the two rear bearing snap rings.

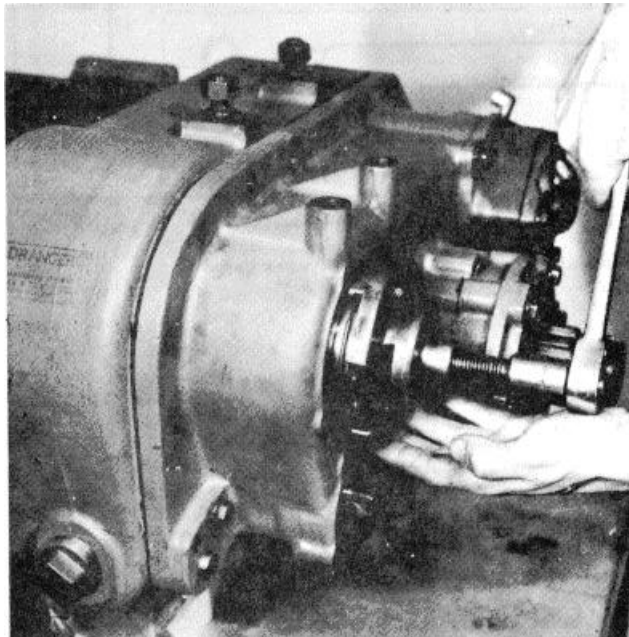

Attach a bearing puller to each snap ring and remove both rear bearings from the counter shafts.

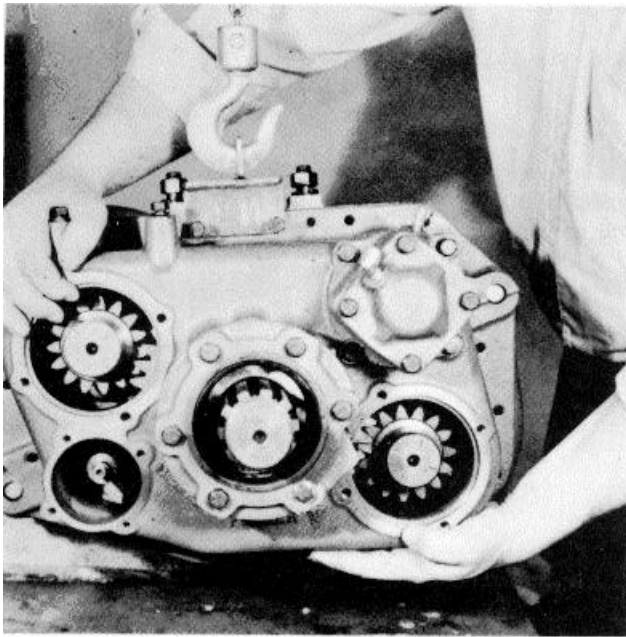

Remove the two remaining capscrews. Attach a chain hoist to the rear housing and move the assembly straight to the rear and away from the intermediate housing, taking care not to damage the oil trough located at the top rear of the intermediate housing. Mount the assembly in a vise in the upright position.

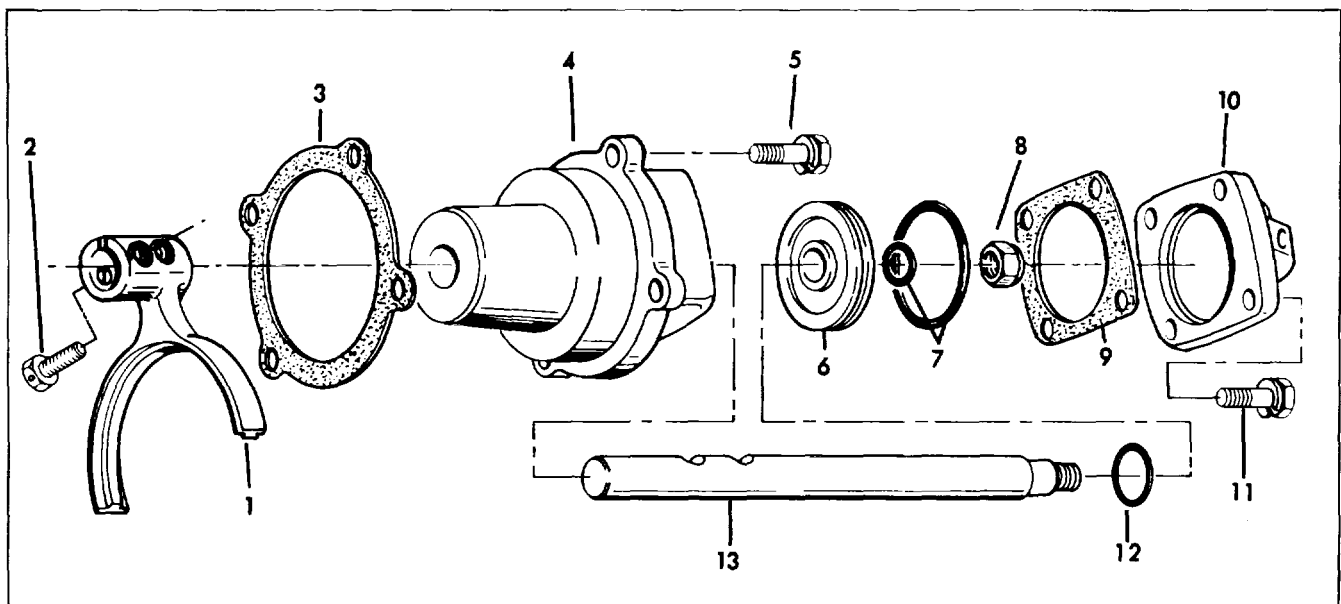

- | | | |
|-----------------------|---------------------|--------------------|
| 1. Shift Yoke | 6. Piston | 11. Capscrew (4) |
| 2. Yoke Lockscrew (2) | 7. O-Ring | 12. Housing O Ring |
| 3. Gasket | 8. Elastic Stop Nut | 13. Shift Yoke Bar |
| 4. Cylinder Housing | 9. Gasket | |
| 5. Capscrew (4) | 10. Cylinder Cover | |

Illustration 4-34. Auxiliary Shift Cylinder.

6. Disassemble Auxiliary Shift Cylinder.

NOTE

SEE ILLUSTRATION 4-34 FOR EXPLODED VIEW OF AUXILIARY SHIFT CYLINDER.

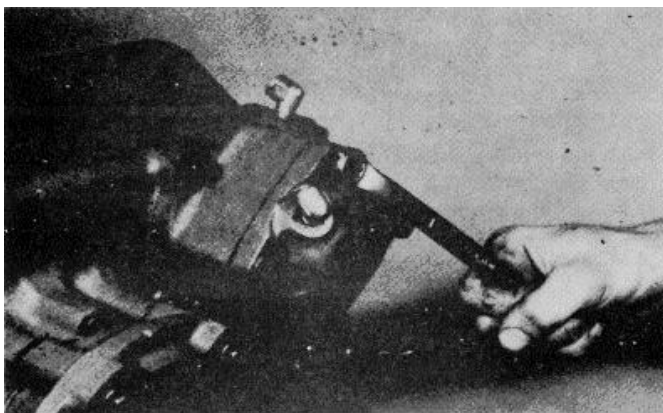

Turn out the four cap screws and remove the cover from the shift cylinder.

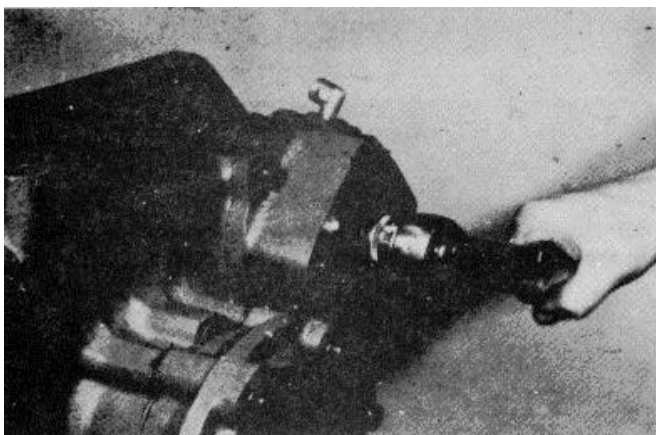

Remove the locknut from the shifting shaft in the cylinder.

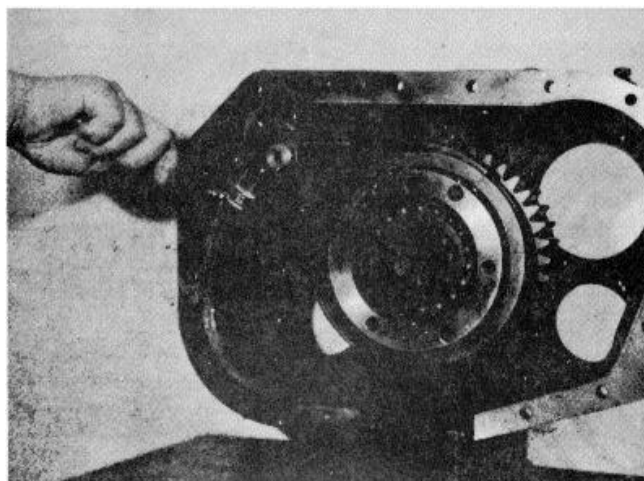

Cut the lockwire and turn out the two yoke lock screws.

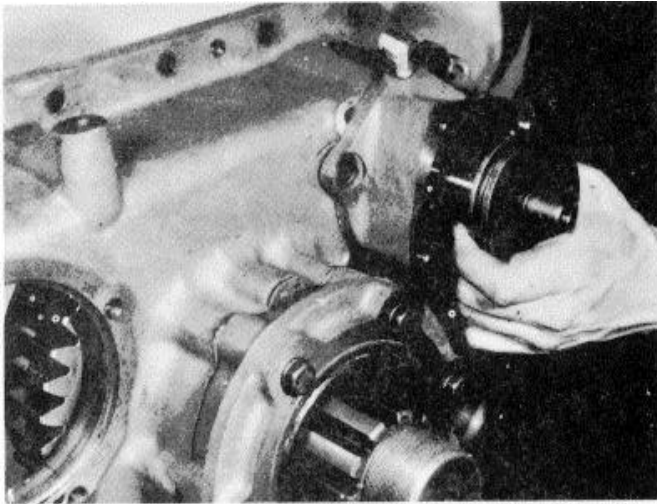

Push the shifting shaft and piston to the rear and remove from the cylinder housing. At the same time remove shifting yoke from sliding clutch gear.

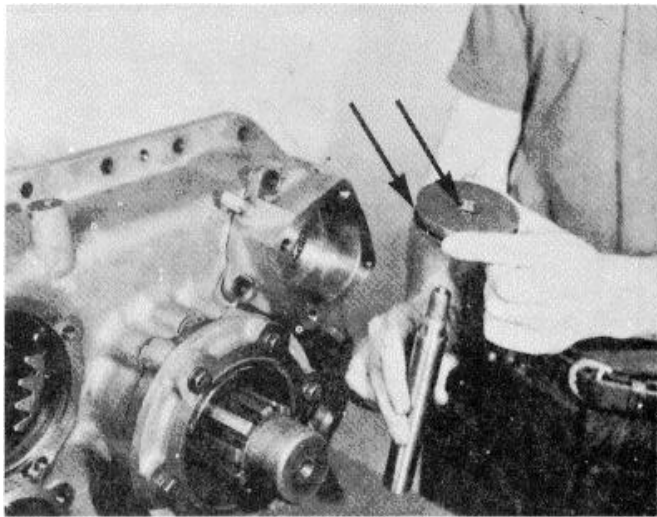

Remove the piston from the shaft and remove the O-rings on the inner and outer diameters of the piston.

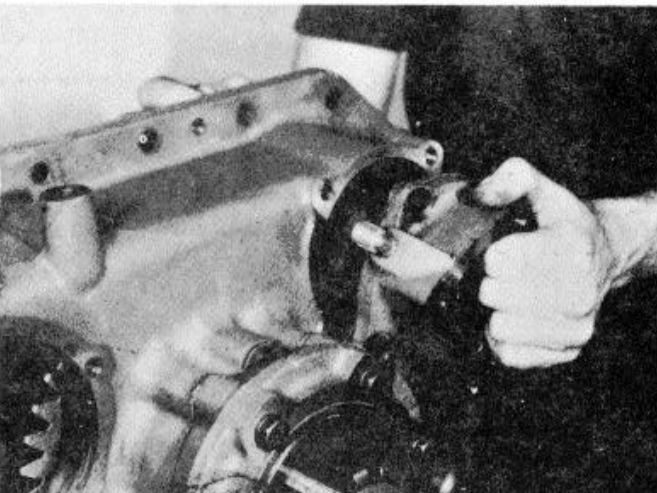

Turn out the four cap screws and remove the cylinder housing from the bore in the auxiliary rear housing. Remove the O-ring from the bore in the cylinder housing. Remove synchronizer assembly from splines of tailshaft.

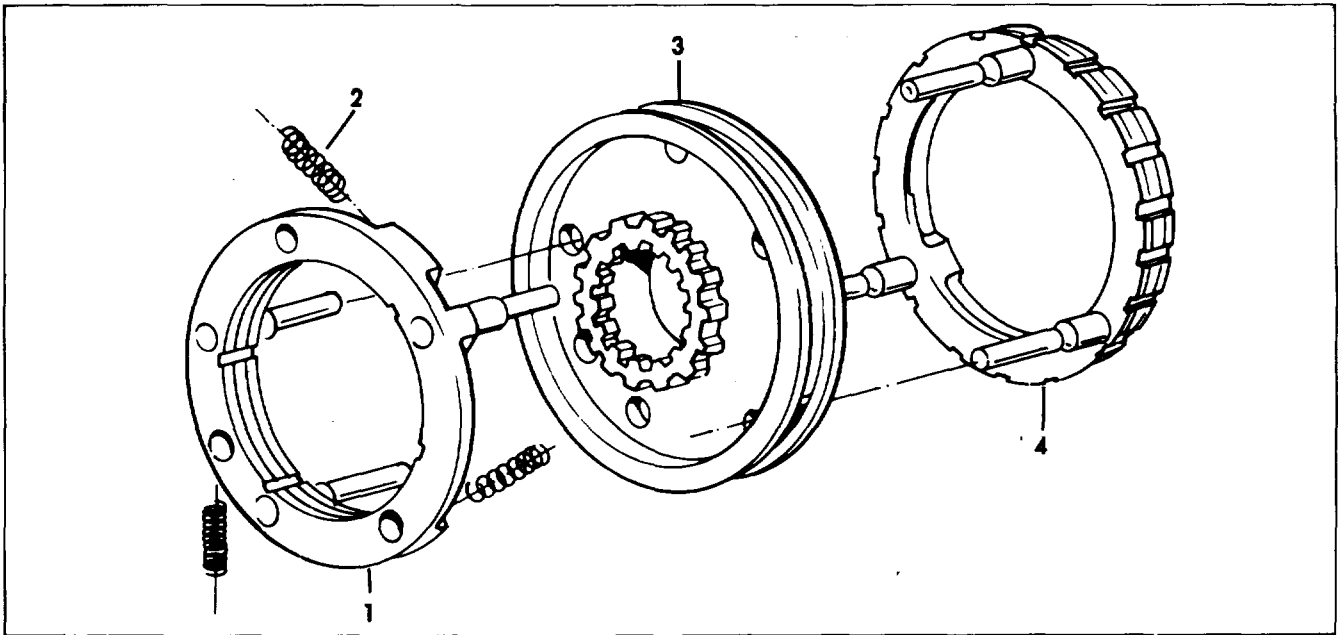

1. Direct Ring
2. Spring
3. Sliding Clutch
4. Low Speed Ring

Illustration 4-35. Synchronizer Assembly.

7. Disassemble Synchronizer Assembly.

NOTE

SEE ILLUSTRATION 4-35 FOR EXPLODED VIEW OF THE SYNCHRONIZER ASSEMBLY.

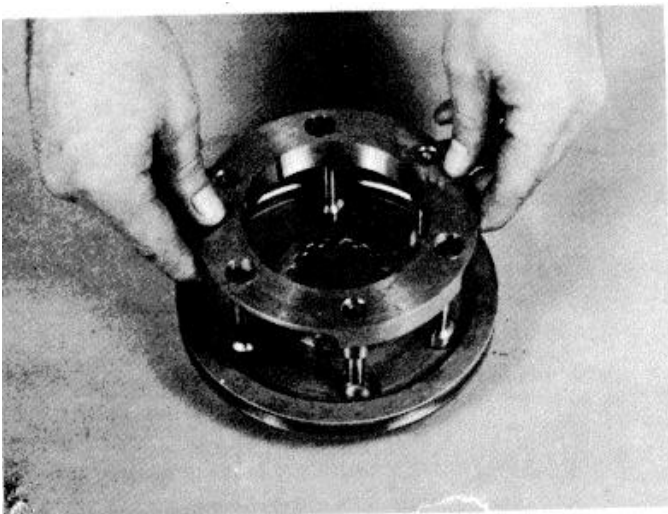

Pull the direct synchronizer from the blocker pins of the low speed synchronizer. Place a cloth over rings during removal as the three springs in the direct ring will be released at the pin locations.

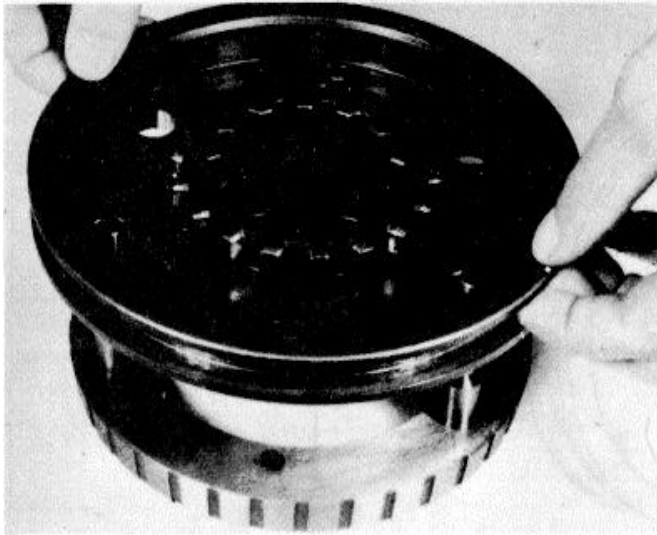

Remove the sliding clutch from the low speed synchronizer.

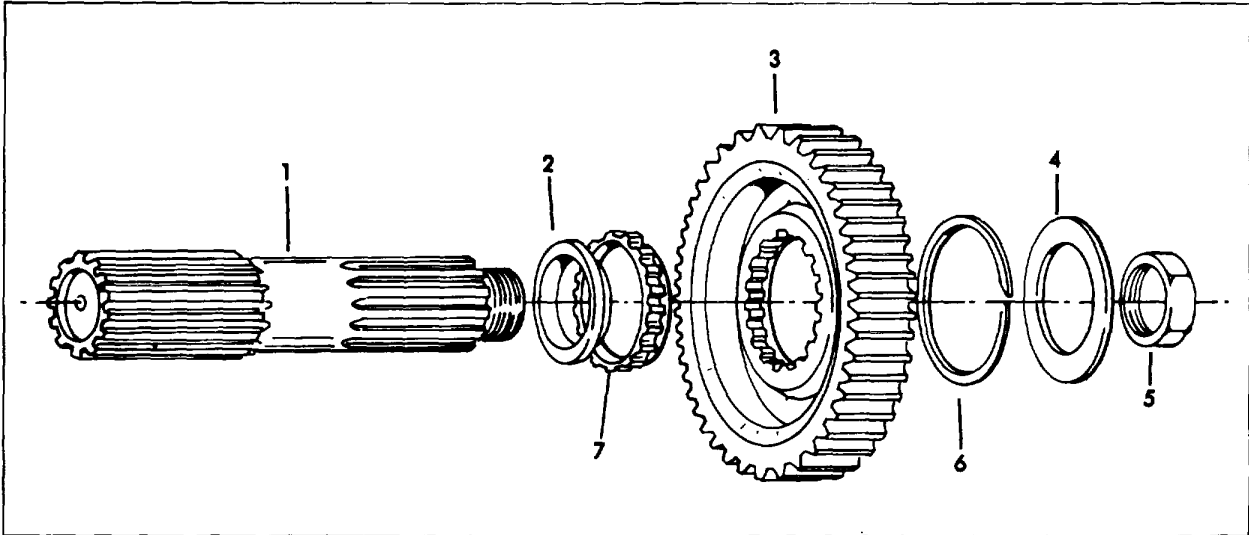

1. Tailshaft
2. Stepped Washer
3. Low Speed Gear
4. Washer
5. Tailshaft Nut
6. Snap Ring
7. Spined Spacer

Illustration 4-36. Tailshaft and Low Speed Gear Assembly.

8. Remove Tailshaft, and Disassemble Low Speed Gear Assembly.

NOTE

SEE ILLUSTRATION 4-36 FOR EXPLODED VIEW OF THE TAILSHAFT AND LOW SPEED GEAR ASSEMBLY.

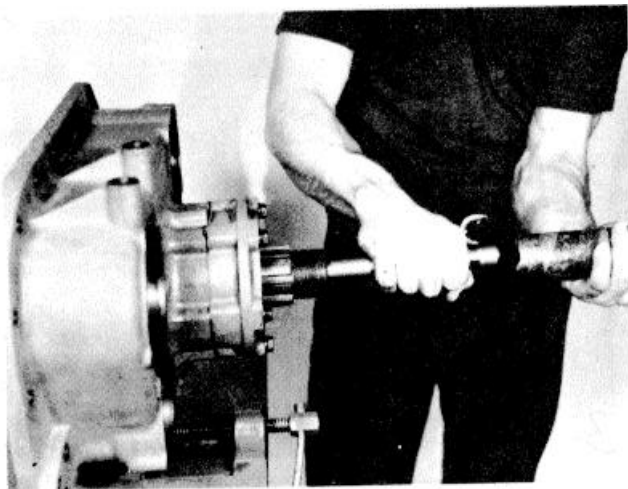

Use a soft bar and mallet against the rear of the tailshaft to move the assembly forward and from the rear bearing.

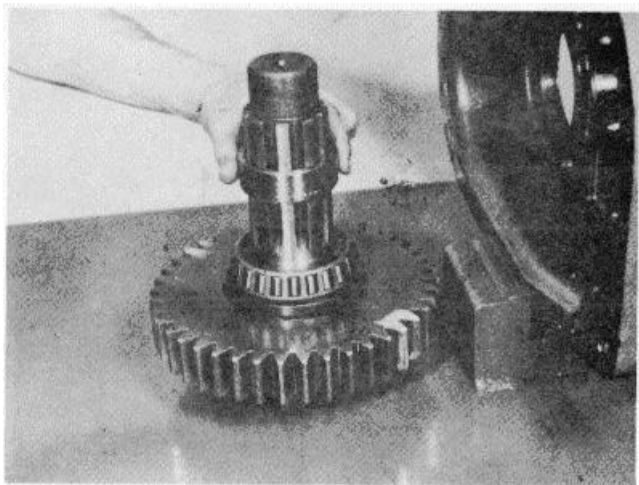

Remove the bearing inner sleeve from the shaft.

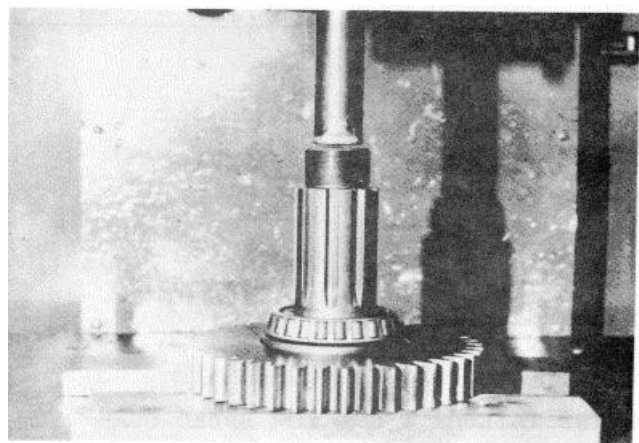

Use the low speed gear as a base. to press the bearing from the shaft and to free the gear and rear washer.

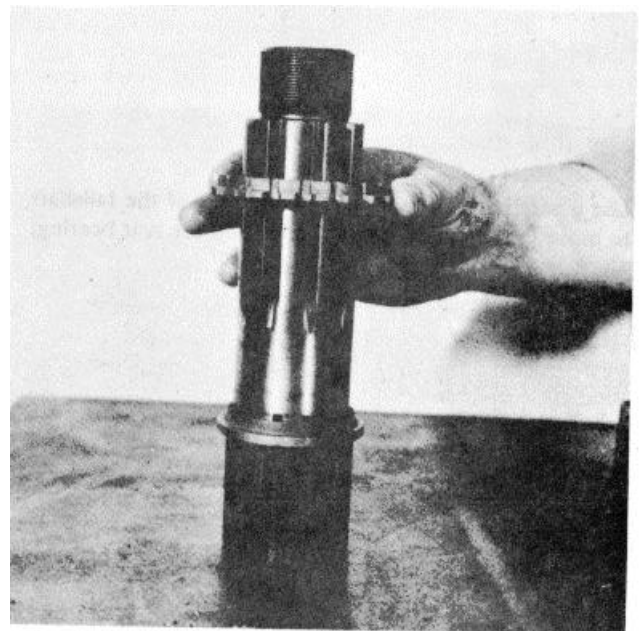

Remove the splined washer from the shaft.

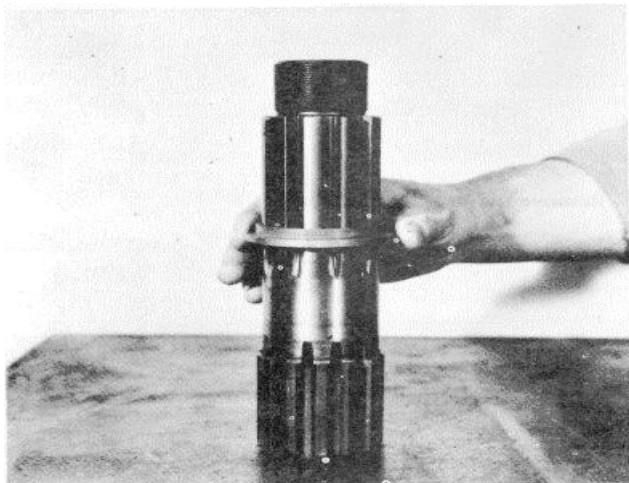

Remove the stepped washer from the shaft.

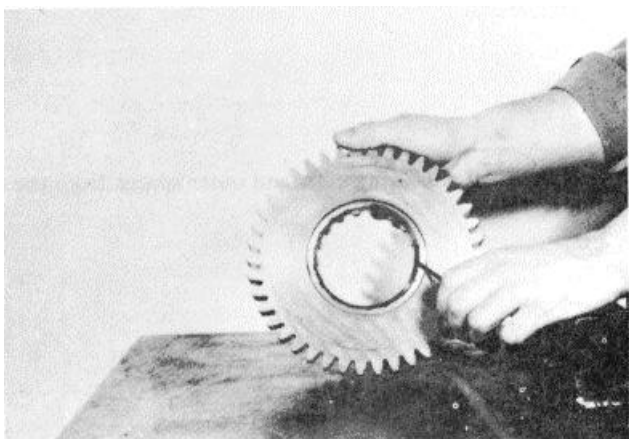

If necessary, remove the snap ring from the inner diameter of the low speed gear.

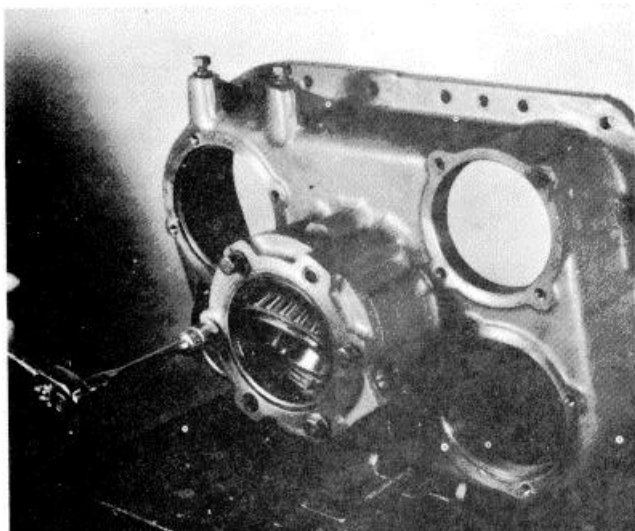

Turn out capscrews and remove the rear bearing cover. If necessary, remove the oil seal from the cover

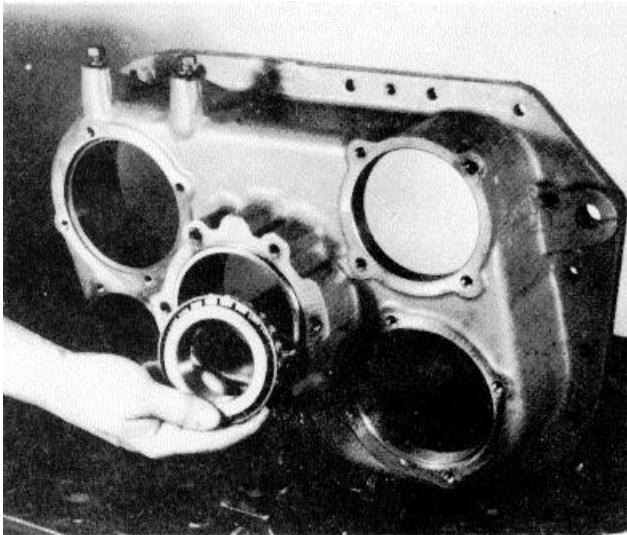

Remove the bearing rear cone.

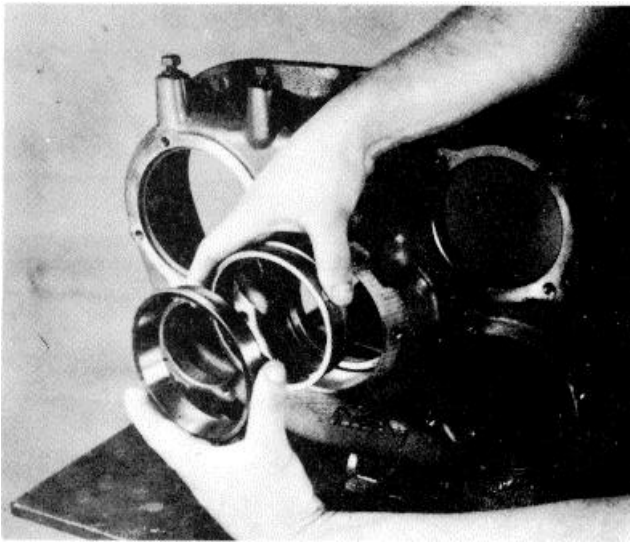

Remove the two bearing cups and outer spacer from the housing bore.

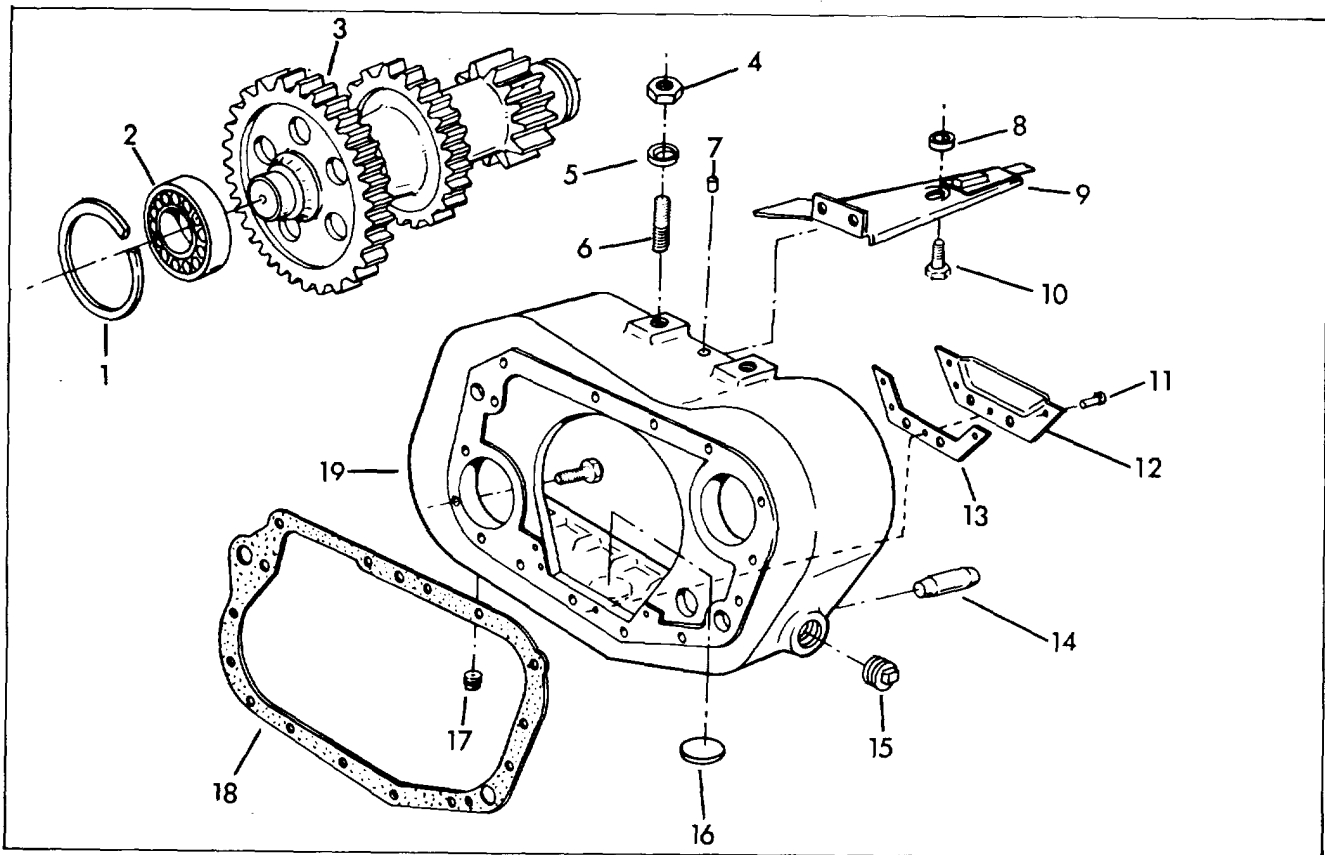

- | | | |
|-------------------------------|---------------------|---------------------|
| 1. Spacer (2) | 7. Plug | 13. Gasket |
| 2. Front Bearing (2) | 8. Spacer | 14. Dowel Pin (2) |
| 3. Auxiliary Countershaft (2) | 9. Oil Trough | 15. Oil Filler Plug |
| 4. Nut (2) | 10. Capscrew | 16. Magnet |
| 5. Washer (2) | 11. Drive Screw (4) | 17. Drain Plug |
| 6. Stud (2) | 12. Oil Reservoir | 18. Gasket |

Illustration 4-37. Auxiliary Intermediate Housing.

9. Disassemble Auxiliary Intermediate Housing.

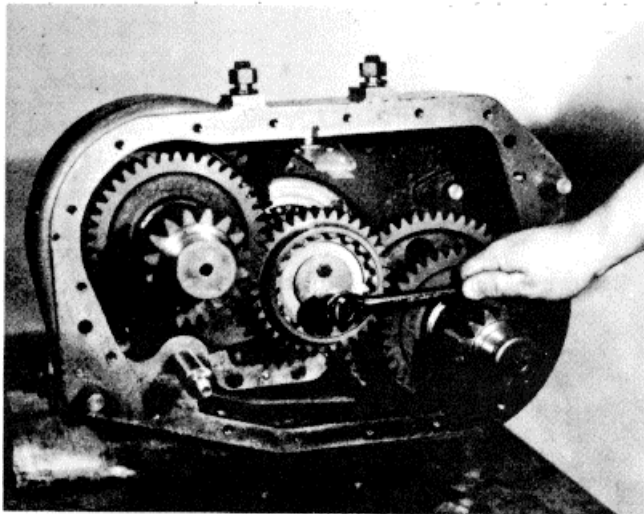

NOTE

SEE ILLUSTRATION 4-37 FOR EXPLODED VIEW OF AUXILIARY INTERMEDIATE HOUSING.

Cut the lockwire, turn out the two cap screws and remove the plate from the rear of the mainshaft.

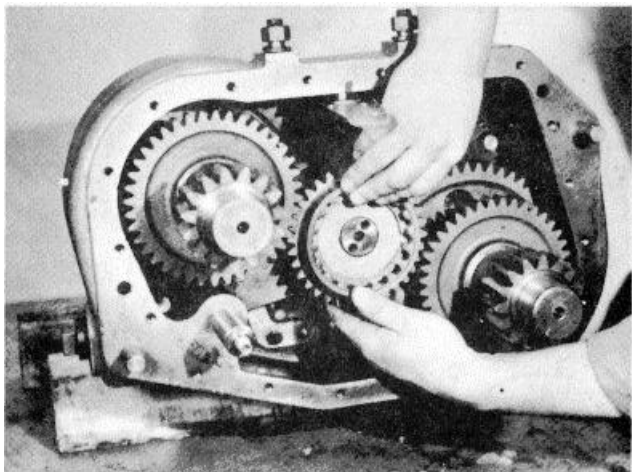

Remove the intermediate drive gear from the shaft and if necessary, remove the two snap rings and plate from the inner diameter of the intermediate drive gear

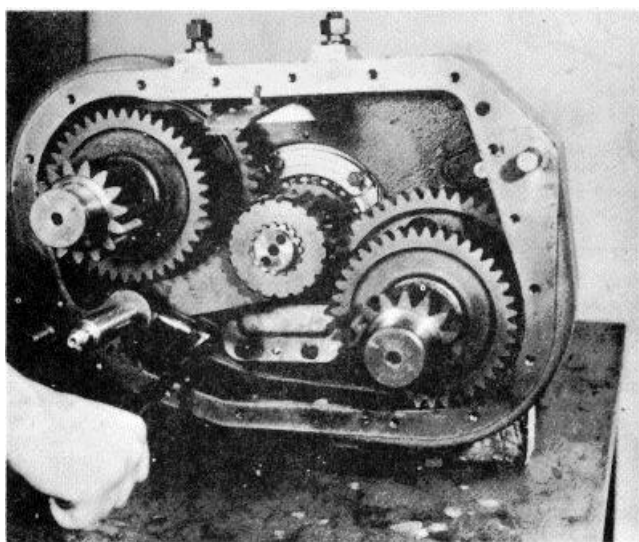

Cut the lockwire and turn out the lock screw from the intermediate shift yoke.

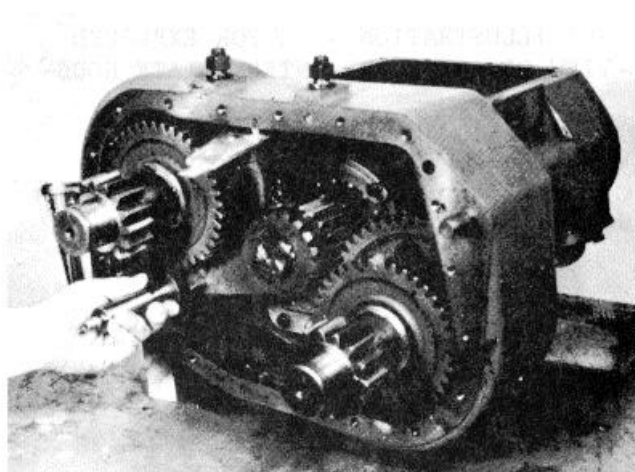

Remove the intermediate shift shaft from the housing.

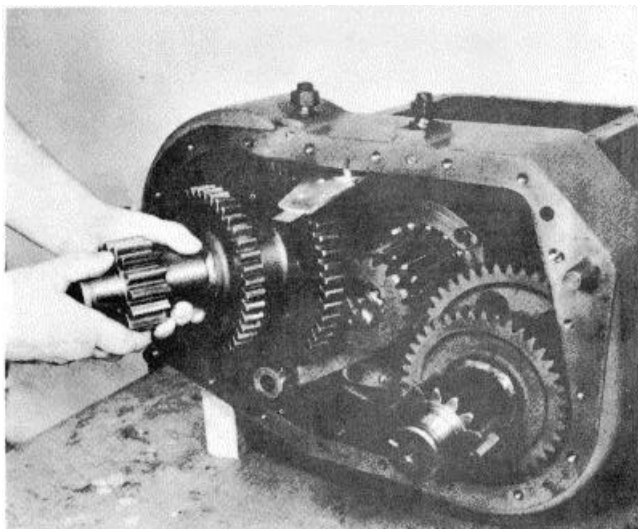

Remove the left countershaft from the housing, using caution to avoid damage to the oil trough.

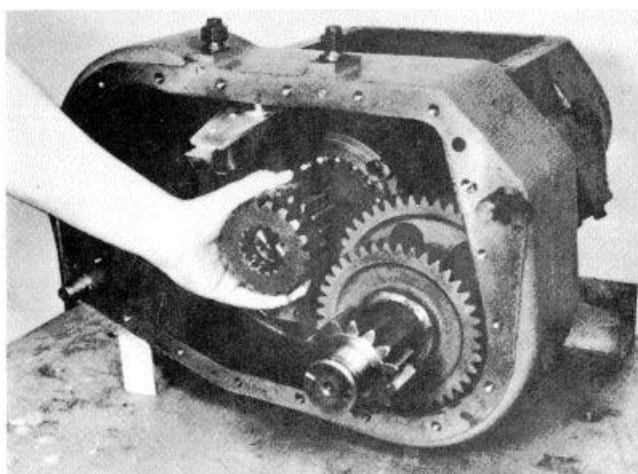

Remove the shift yoke and pull the auxiliary drive gear and sliding clutch assembly from the splines of the mainshaft. Both sections must align with the splines for removal.

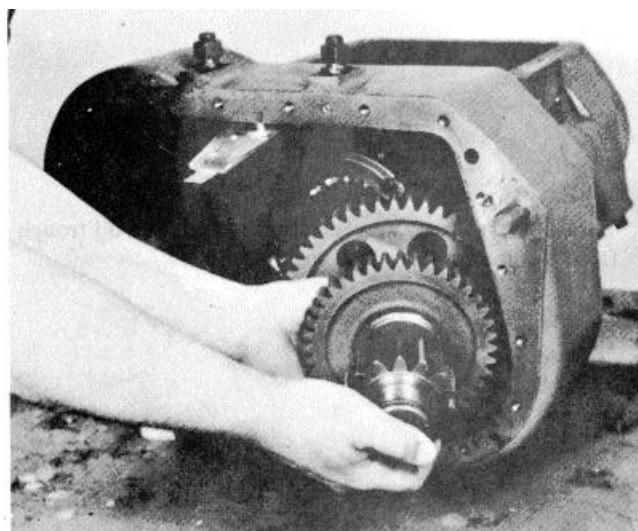

Pull the right auxiliary countershaft from the intermediate case.

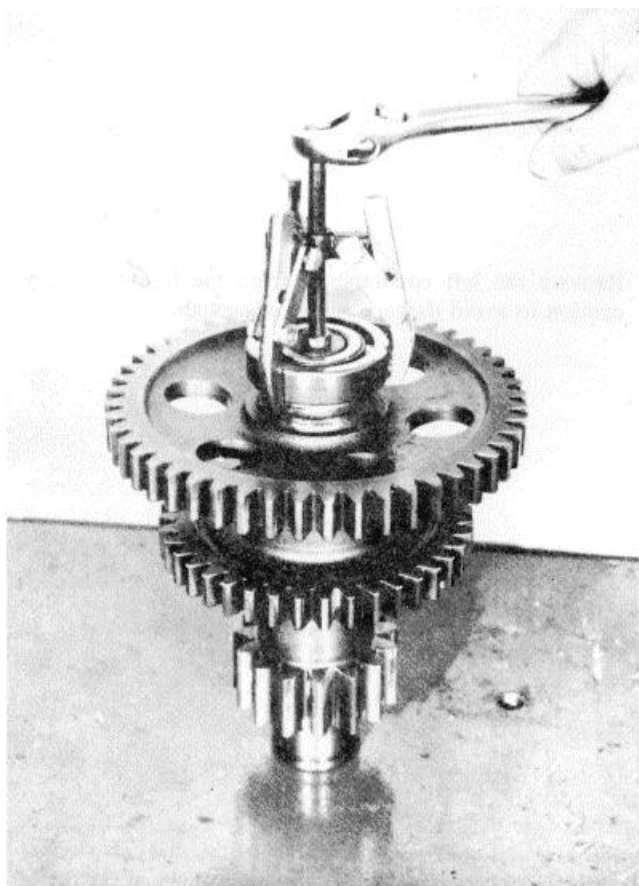

Pull the front bearings from the countershafts if necessary.

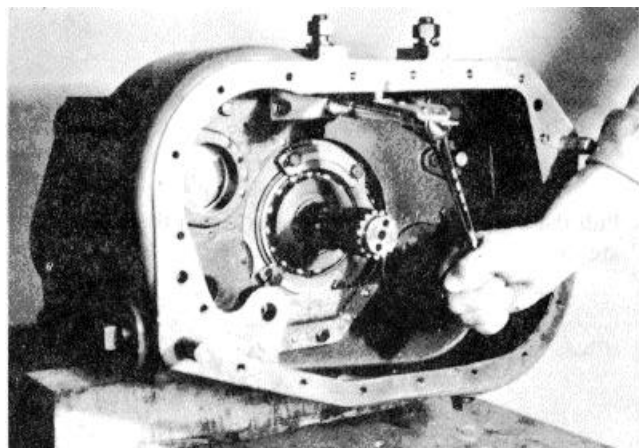

Turn out the three capscrews and remove the oil trough from the intermediate housing.

Remove the snap ring spacers from the front countershaft bearing bores.

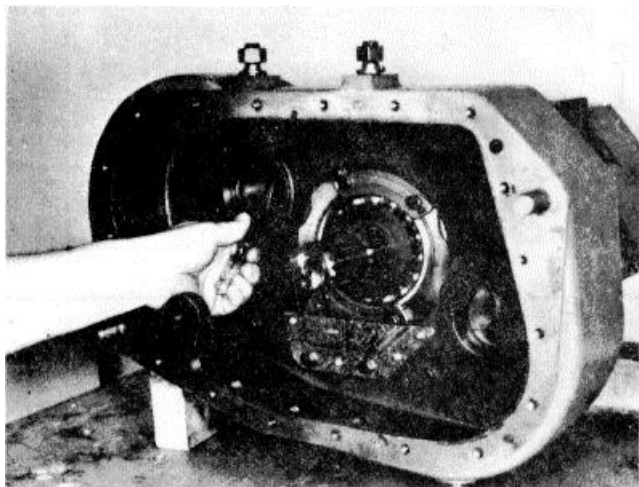

Turn out the 13 remaining capscrews and remove the intermediate housing from the transmission.

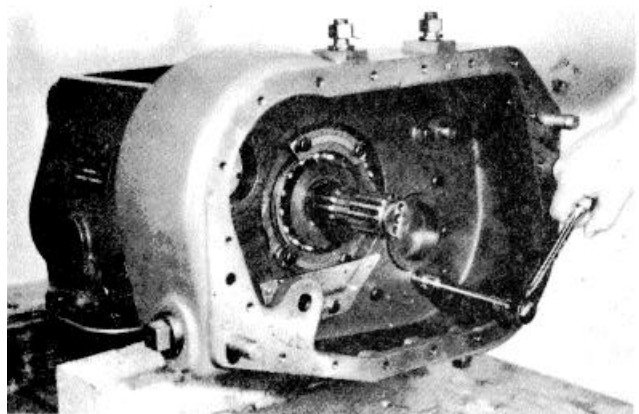

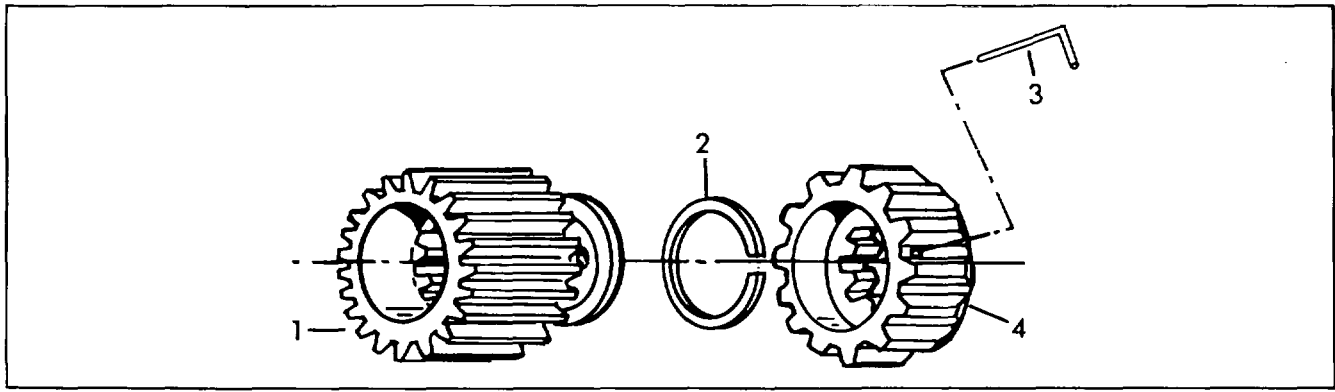

1. Drive Gear 2. Snap Ring 3. Retainer 4. Clutch Gear

Illustration 4-38. Auxiliary Drive Gear / Clutch Gear Assembly

10. Disassemble Auxiliary Drive Gear/Clutch Gear Assembly.

NOTE

SEE ILLUSTRATION 4-38 FOR EXPLODED VIEW OF AUXILIARY DRIVE GEAR/CLUTCH GEAR ASSEMBLY.

NOTE

ASSEMBLY SHOULD BE DISASSEMBLED ONLY IF ABSOLUTELY NECESSARY. THE RETAINING PIN IS NOT REUSABLE AND MUST BE REPLACED.

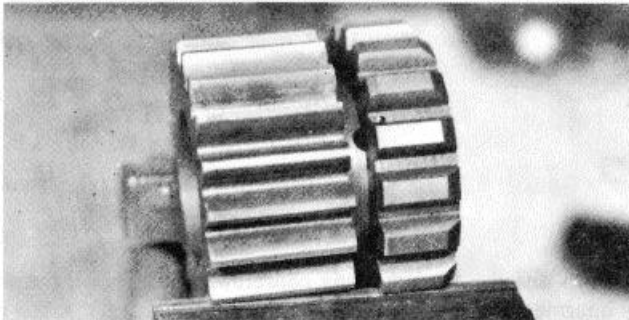

Align one of the holes in the small diameter of the drive gear with the retaining pin of the clutch gear and mount the assembly in a vise.

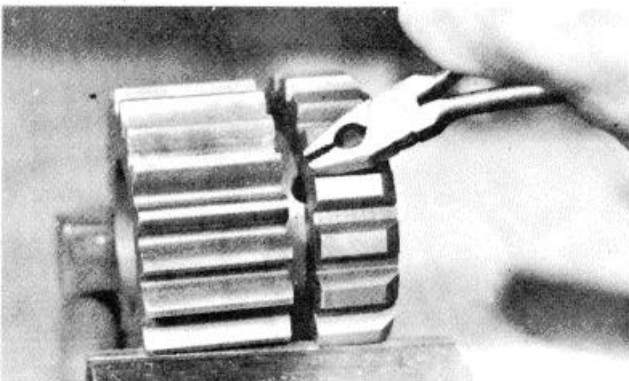

Remove the bended end of the pin and drive the pin down and through the hole in the drive gear

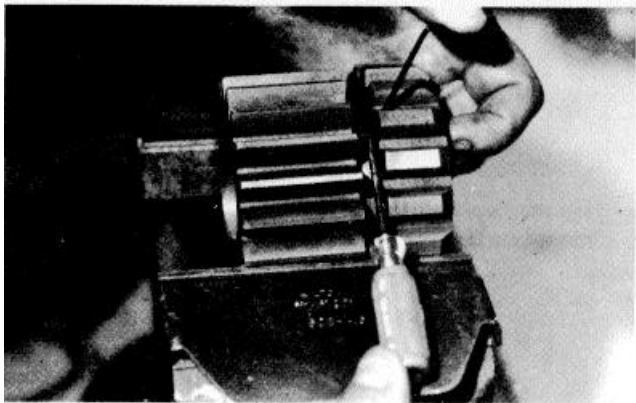

Position the snap ring in the clutch gear so that the retaining pin hole is approximately 1/2" from the open section of the snap ring. Insert a small -Allen wrench or equivalent into the retaining pin hole and force down so that the snap ring is forced out of the groove. Insert a small screwdriver between the snap ring and clutch gear and pry the snap ring from the groove.

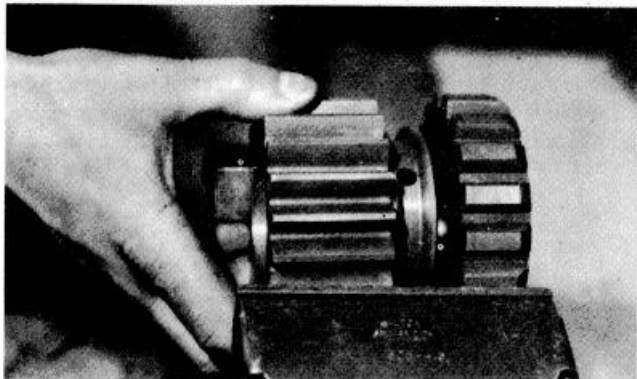

Remove the drive gear from the clutch gear and, if necessary, remove the snap ring from the drive gear.

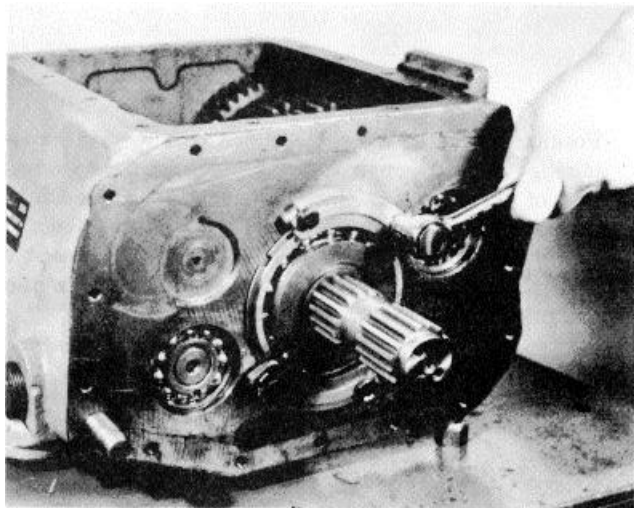

Loosen, but do not remove the two mainshaft rear bearing retainers.

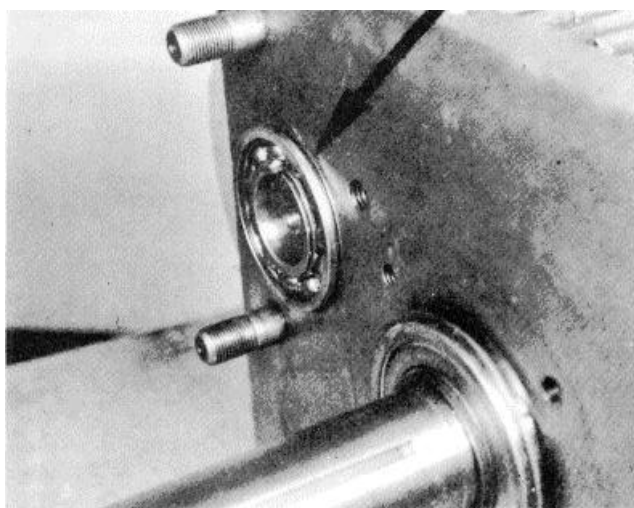

Use a soft bar and mallet against the rear of the right countershaft to drive the assembly as far forward as possible, exposing the snap ring groove in the front bearing.

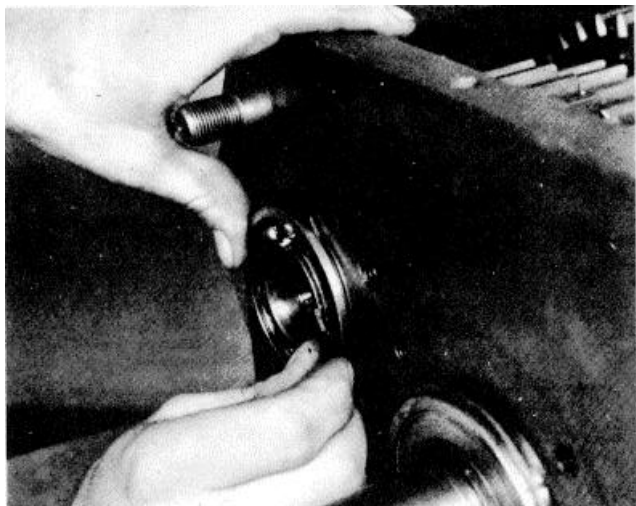

Remove the snap ring from the rear countershaft bearing bore and install in the front bearing snap ring groove.

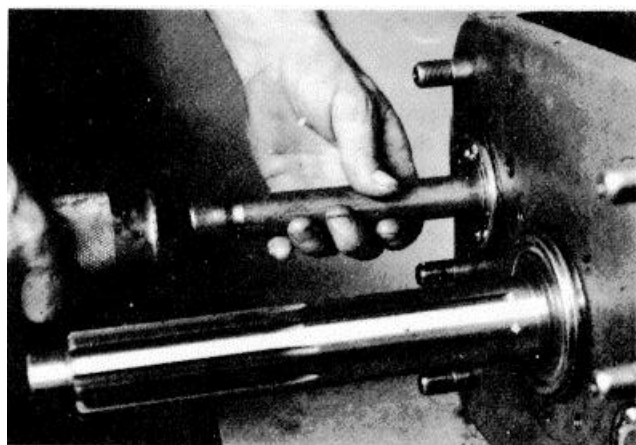

Use a soft bar and mallet to move the assembly to the rear as far as possible. partially unseating the front bearing from the shaft.

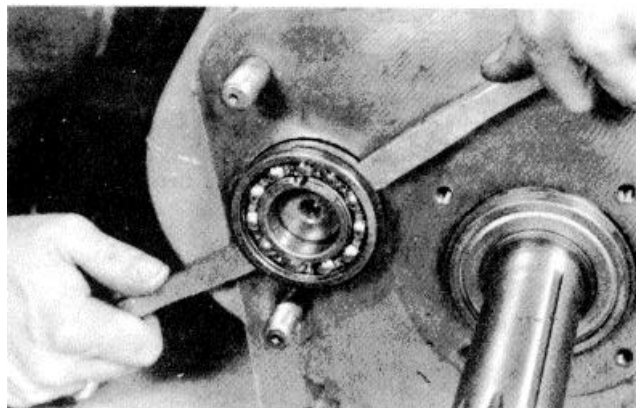

Move the countershaft forward and remove the front bearing with a puller or pry bars.

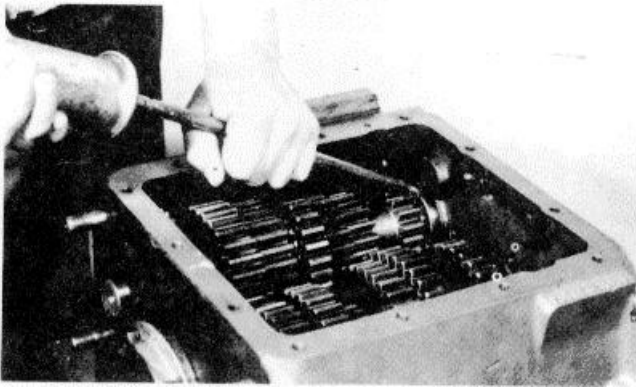

Use a blunt punch or equivalent from inside the case and tap the rear bearing back approximately $\frac{1}{4}$ " on the shaft. Tap on the outer race to avoid damaging the bearing.

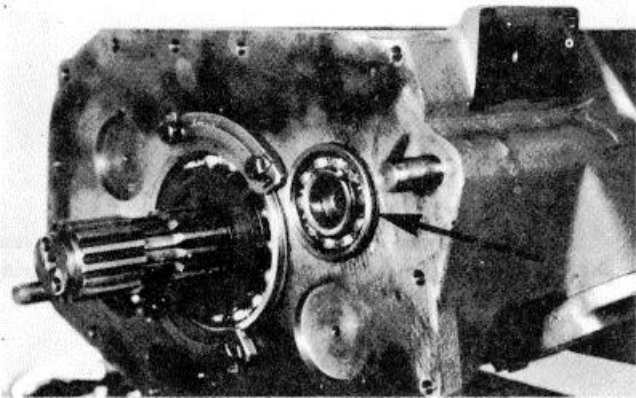

Use a soft bar and a mallet to drive the countershaft to the rear, exposing the snap ring groove in the rear bearing

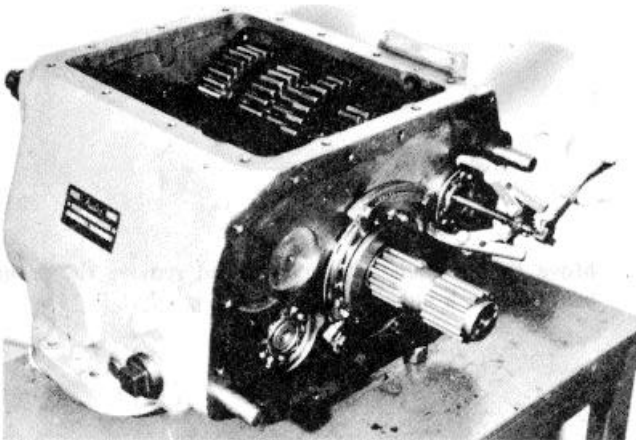

Remove the snap ring from the front bearing and install on the rear bearing. Use a puller or pry bars to remove the rear bearing, and re-tighten the two mainshaft rear bearing retainers

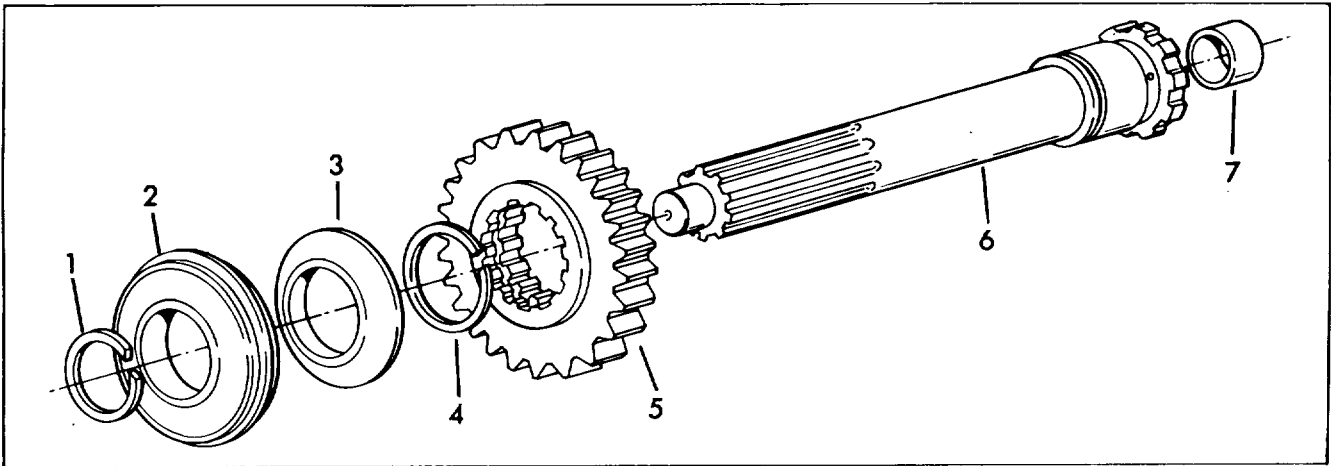

1. Snap Ring
2. Front Mainshaft Bearing
3. Spacer
4. Snap Ring
5. Drive Gear
6. Clutch Shaft
7. Bushing

Illustration 4-39. Clutch Shaft.

12. Remove Clutch Shaft.

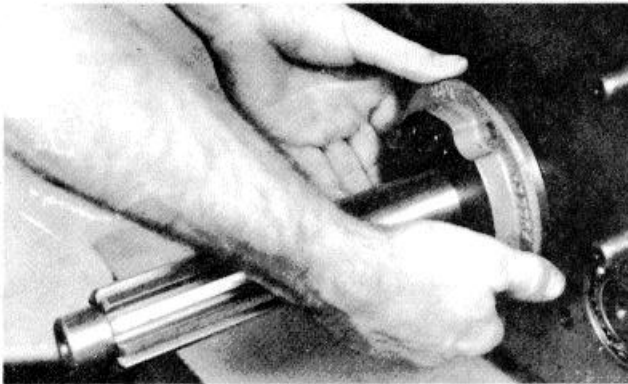

NOTE
SEE ILLUSTRATION 4- 39 FOR
EXPLODED VIEW OF CLUTCH
SHAFT.

Remove the front bearing cover or upshift clutch brake plate.

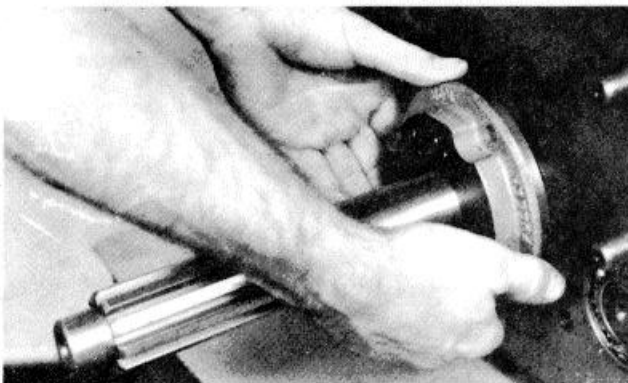

Move the drive gear and shaft as far forward as possible and remove the snap ring from the groove in the clutch shaft.

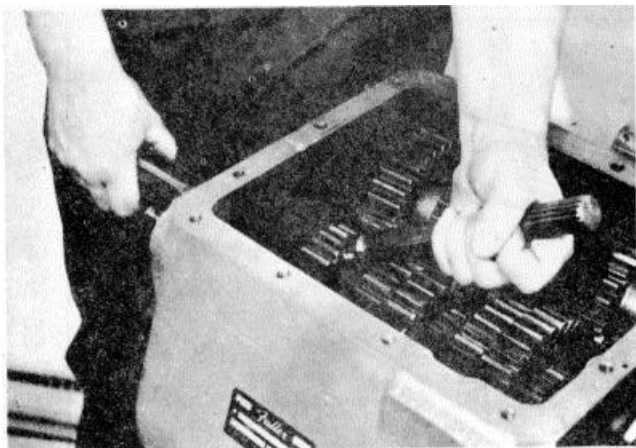

Hold The shaft in position and then tap the drive gear forward to unseat the front main shaft bearing.

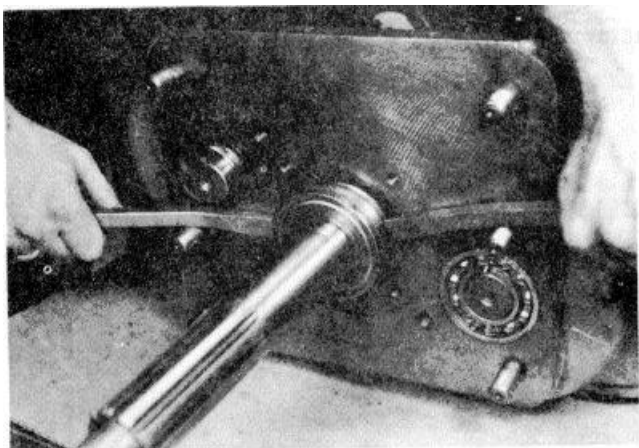

Use a puller or pry bars to remove the bearing from the shaft.

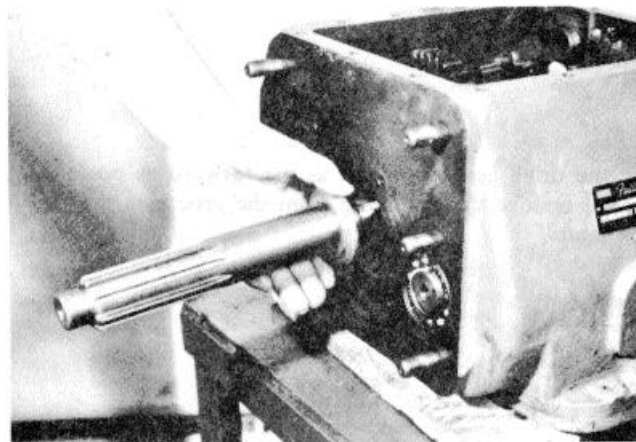

Remove the spacer from the shaft.

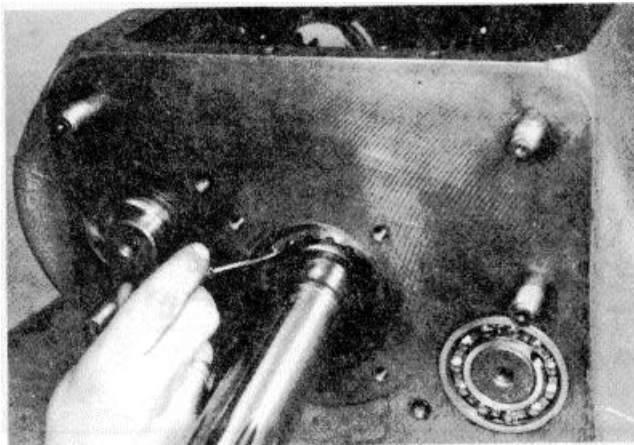

Remove the snap ring from the inner diameter of the drive gear.

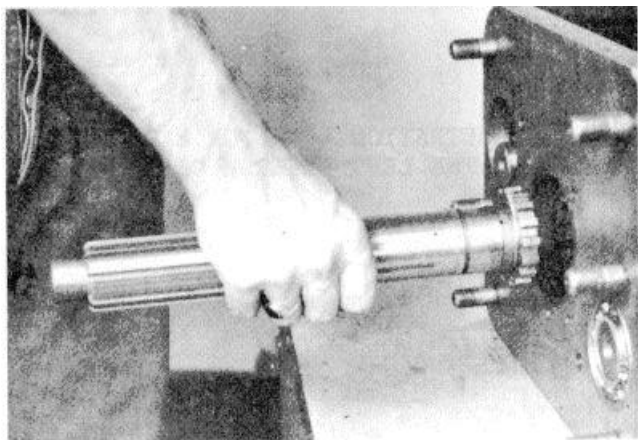

Pull the shaft forward and from the splines of the drive gear.

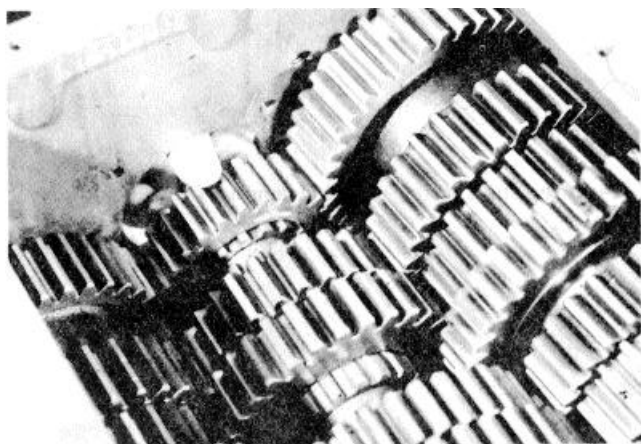

Move the drive gear to the rear and against the 4th speed gear, engaging the splines of the sliding clutch.

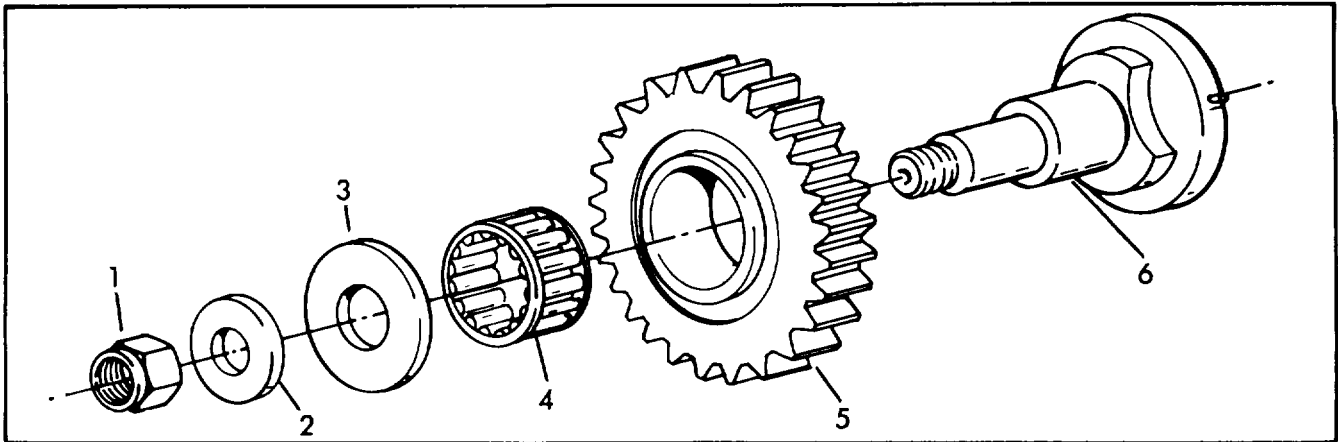

1. Elastic Stop Nut
2. Washer
3. Thrust Washer
4. Needle Bearing
5. Idler Gear
6. Idler Shaft and Pin Assembly

Illustration 4-40. Left Reverse Idler Gear.

13. Disassemble Left Reverse Idler.

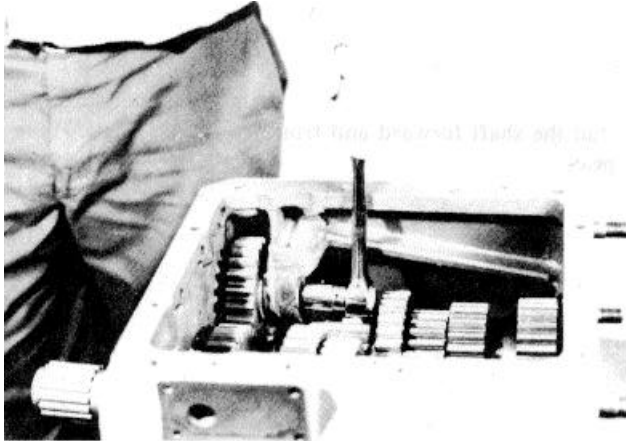

NOTE

SEE ILLUSTRATION 4- 40 FOR EXPLODED VIEW OF THE LEFT REVERSE GEAR.

Remove the elastic stop nut and washer from the reverse idler shaft.

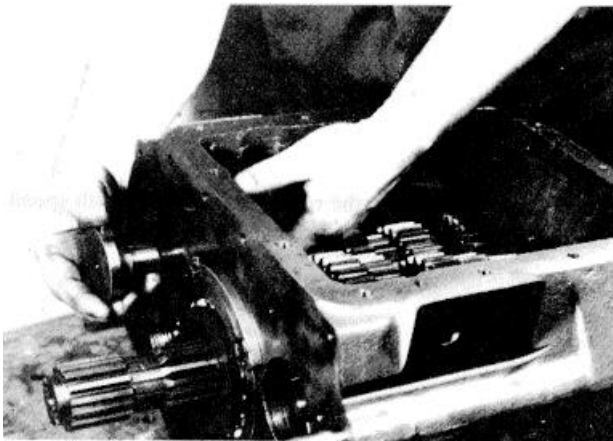

Push the shaft to the rear and remove front the case.

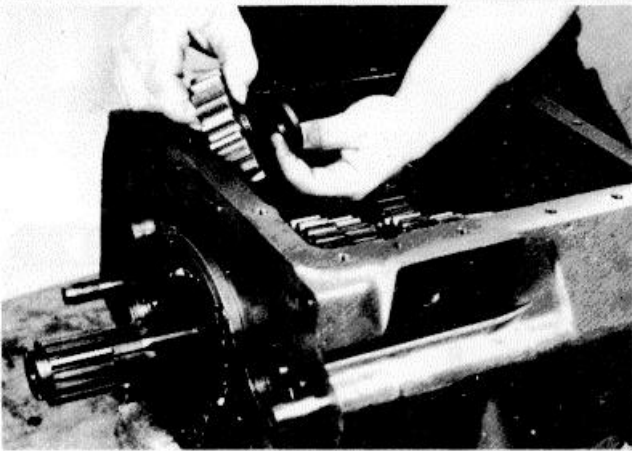

Remove the thrust washer and gear from the case.

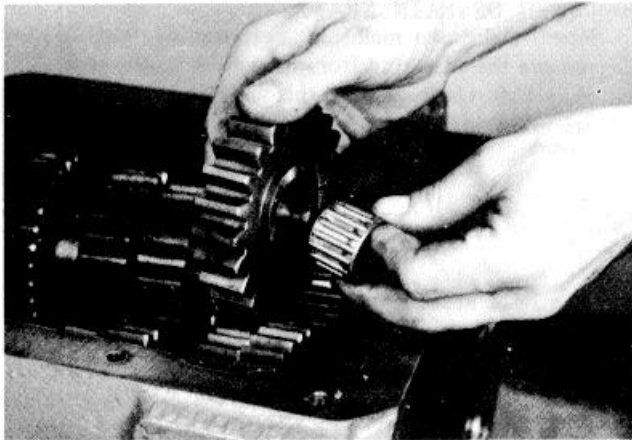

Remove the needle bearing from the gear.

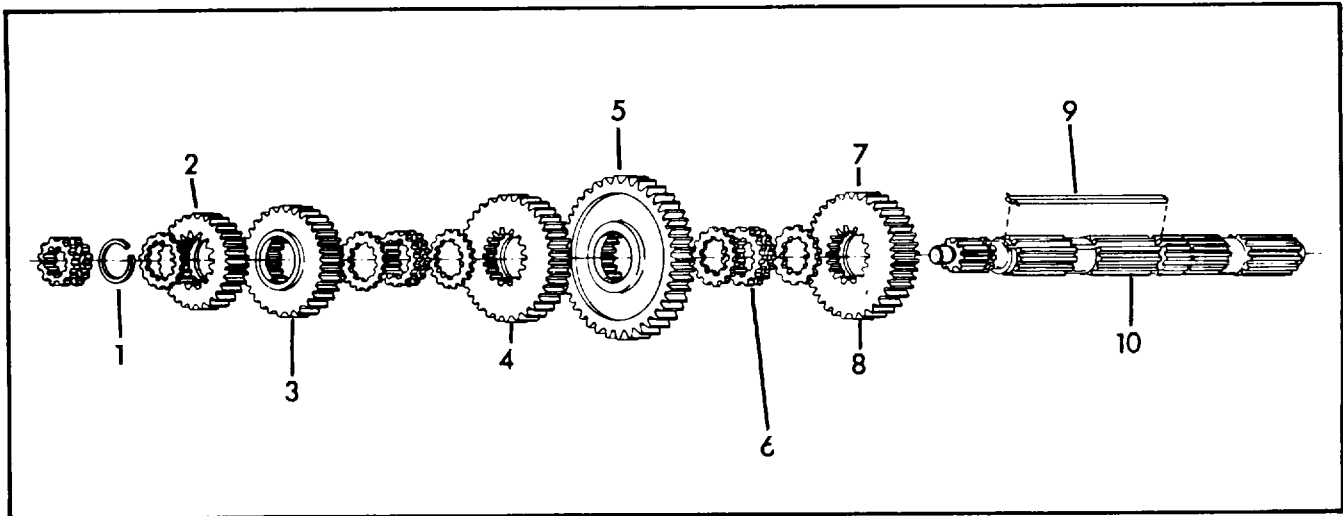

- | | |
|--|-------------------------|
| 1. Snap Ring | 6. Sliding Clutch Gear |
| 2. 4th Speed Gear (RT-613)
Overdrive Gear (RTO-613) | 7. Splined Washer |
| 3. 3rd Speed Gear | 8. Reverse Gear |
| 4. 2nd Speed Gear | 9. Key and Pin Assembly |
| 5. 1st Speed Gear | 10. Mainshaft |

Illustration 4-41. Main Shaft.

14. Disassemble Main Shaft.

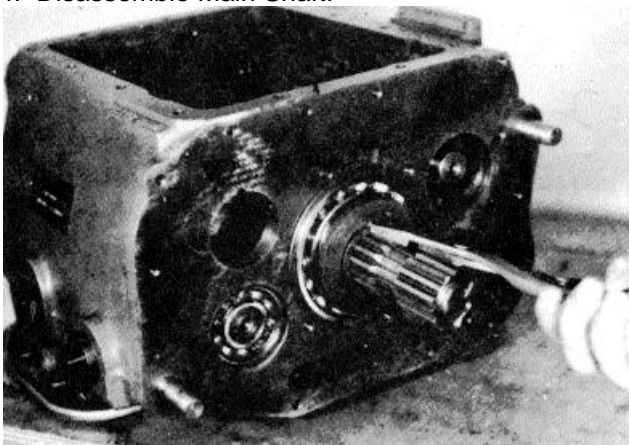

NOTE

SEE ILLUSTRATION 4-41 FOR EXPLODED VIEW OF MAIN SHAFT.

Remove the two mainshaft rear bearing retainers, and remove the snap ring from the groove in the rear of the mainshaft. Use caution as this will free the spring-loaded centering ring.

NOTE:

It may be necessary to relieve pressure on the snap ring by tapping on the front of the mainshaft.



Remove the splined retainer from the mainshaft.

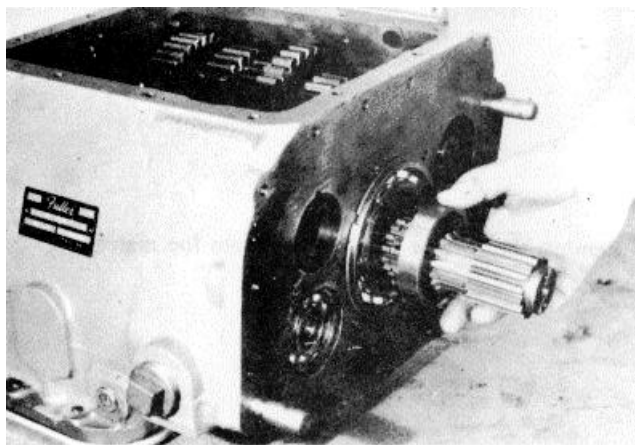

Center the front of the mainshaft in the case bore and remove the centering ring. Remove the six springs from the centering ring.

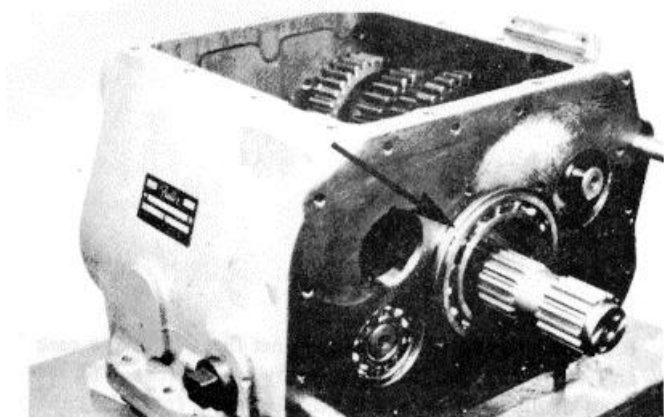

Keep the mainshaft centered and tap to the rear to expose the mainshaft rear bearing snap ring.

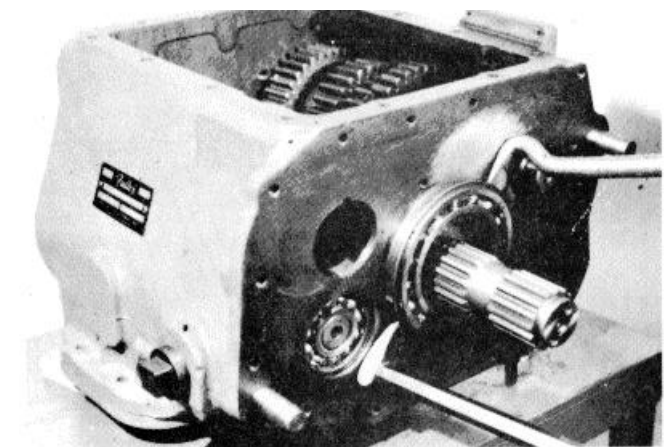

Remove the bearing from the case with pry bars.

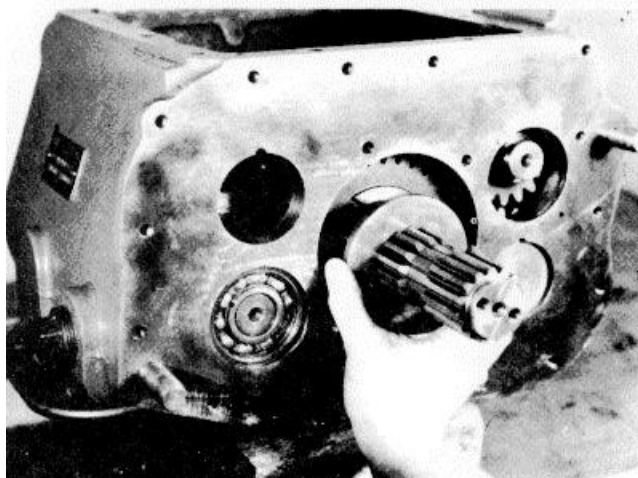

Remove the reverse gear washer from the mainshaft.

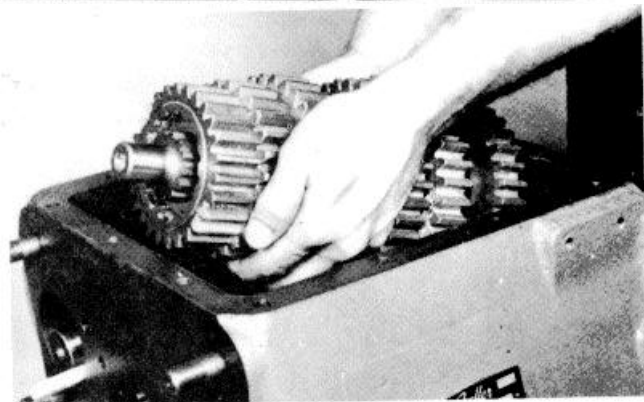

Block the right countershaft against the side of the case and move the mainshaft assembly to the rear. Tilt the front of the shaft up and lift the assembly from the case. Use caution as the reverse gear is free and can fall from the shaft during removal. Remove the reverse gear from the mainshaft.

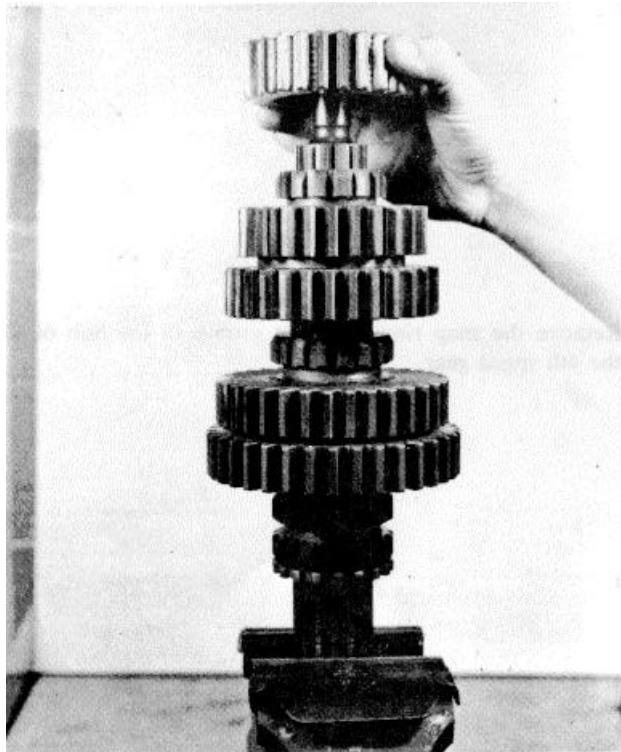

Secure the mainshaft assembly in a vise with the pilot (front) end up and remove the drivegear.



Remove the 4th-5th speed sliding clutch.

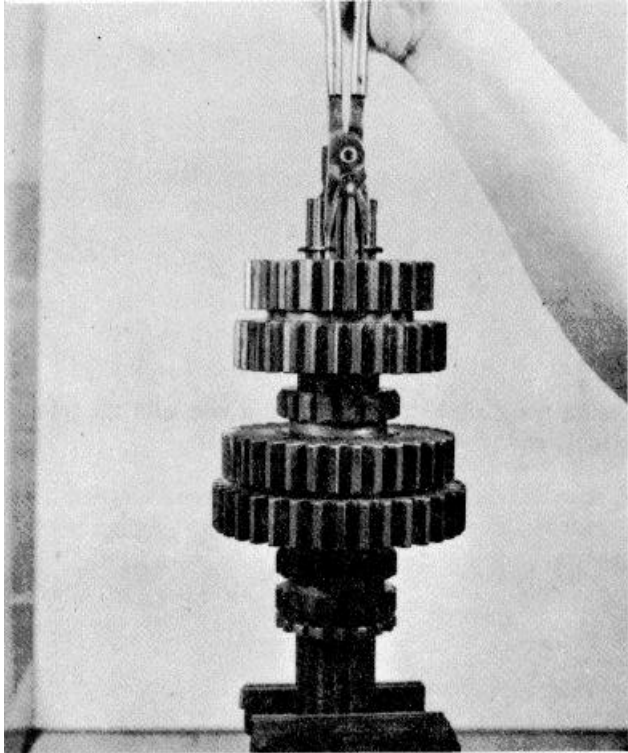

Remove the snap ring from the groove in the hub of the 4th speed gear.

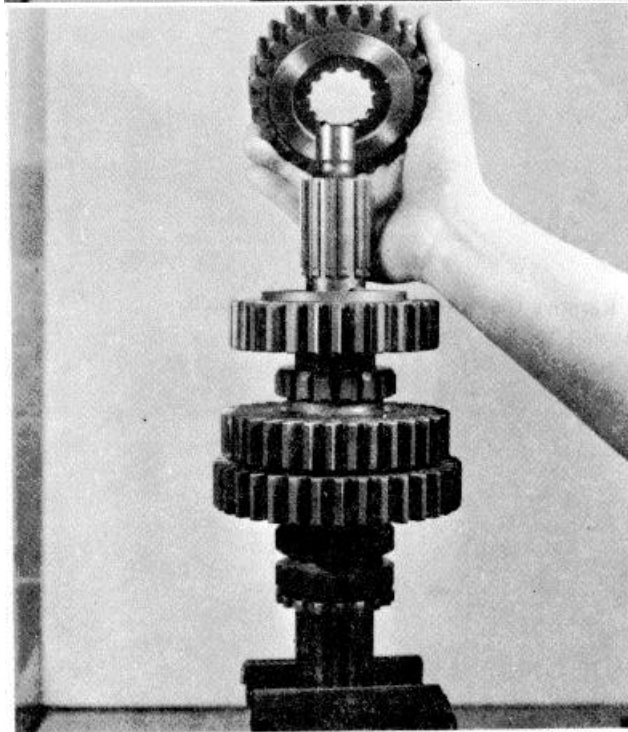

Remove the 4th speed gear and splined washer.

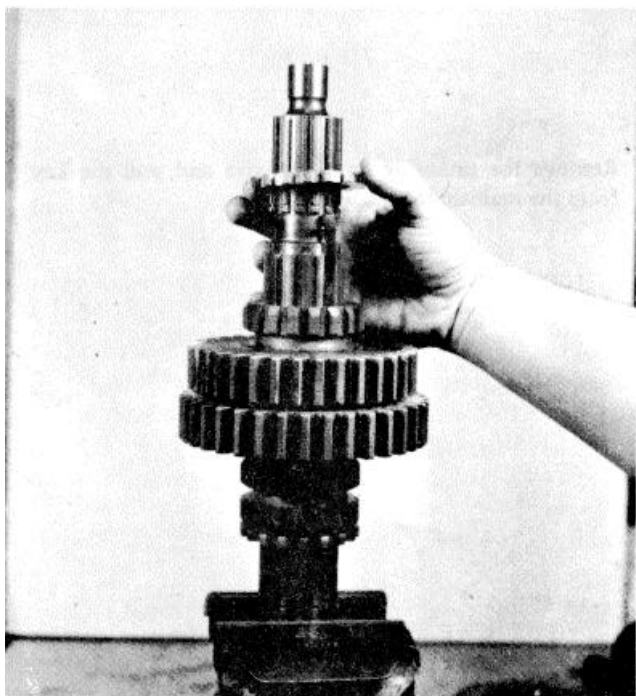

Remove the 3rd speed gear.

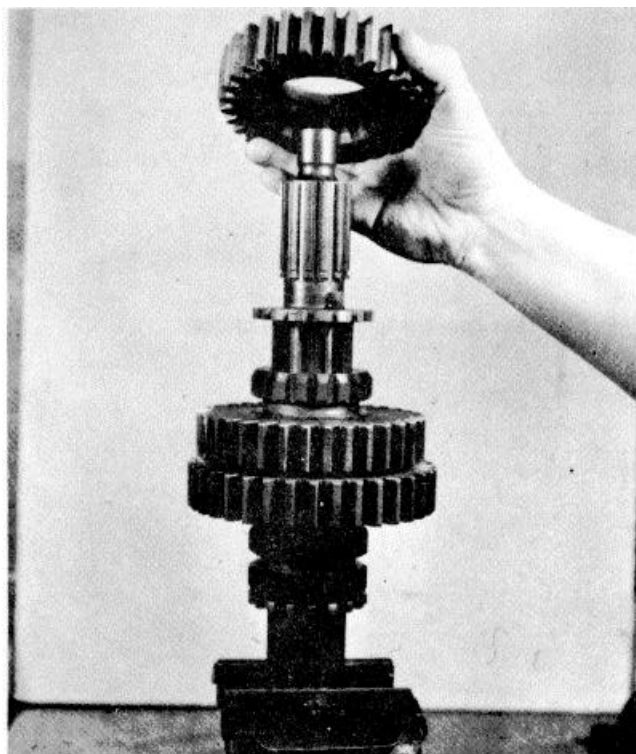

Lift the key and remove the 3rd speed gear splined washer.

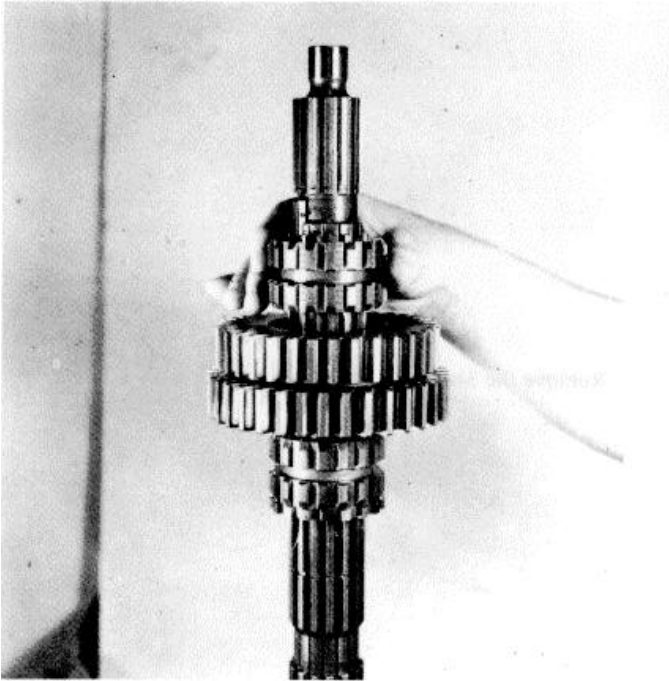

Remove the 2nd-3rd speed sliding clutch.

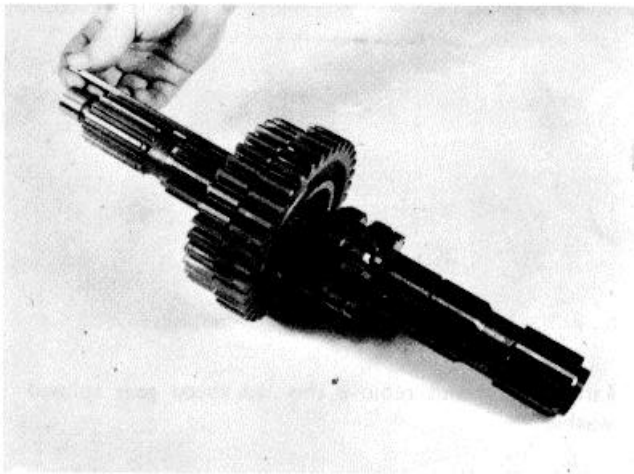

Remove the assembly from the vise and pull the key from the mainshaft.

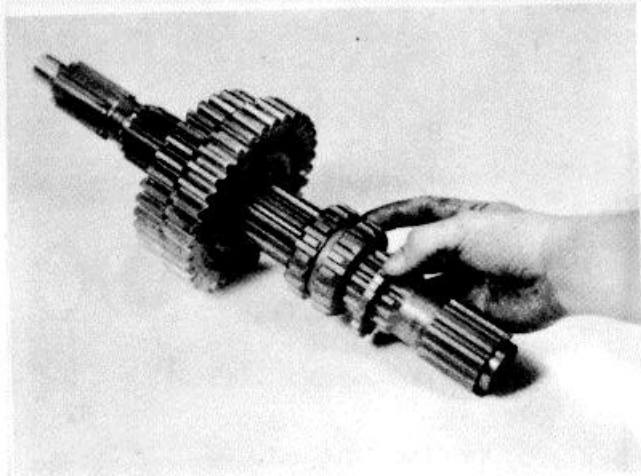

Remove the reverse gear splined spacer and the 1st-reverse sliding clutch.

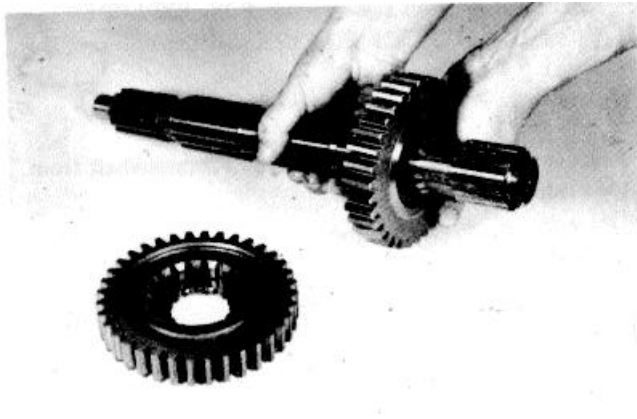

Remove the 1st and 2nd speed gears and splined spacers.

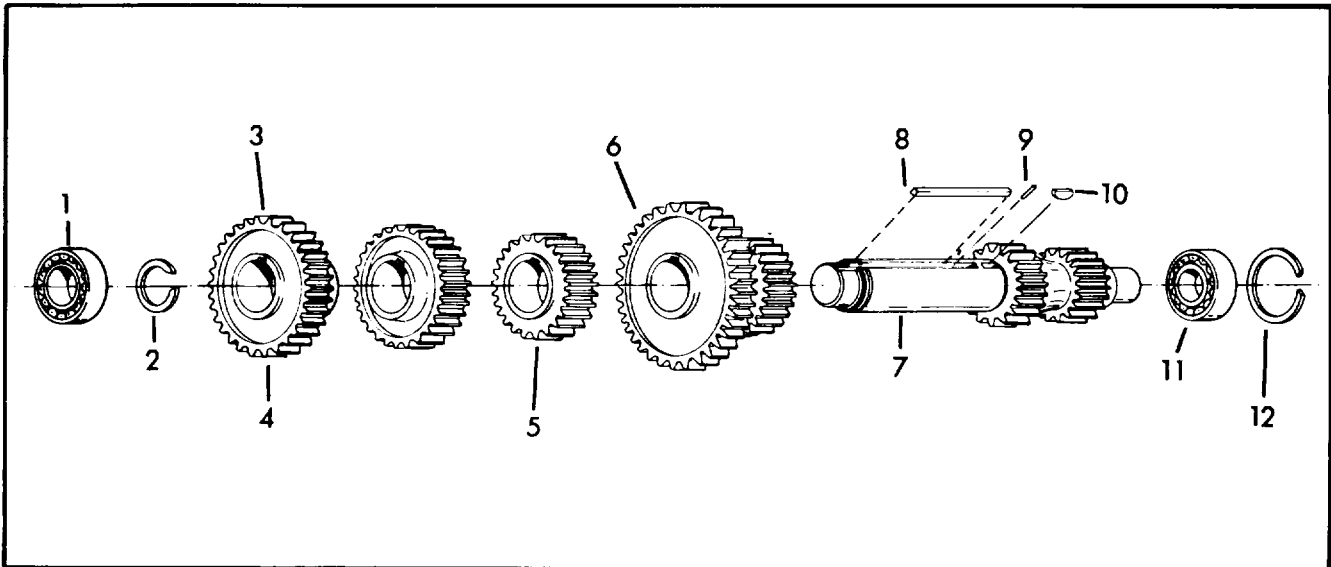

- | | | |
|---|-------------------------------|------------------|
| 1. Front Bearing | 5. 3rd Speed Gear | 10. Woodruff Key |
| 2. Snap Ring | 6. 2nd Speed/PTO Gear Cluster | 11. Rear Bearing |
| 3. 4th Speed Gear (RT-613),
Overdrive Gear [RTO 613] | 7. Countershaft | 12. Snap Ring |
| 4. Drive Gear | 8. Key | |
| | 9. Roll Pin | |

Illustration 4-42. Countershaft Assemblies.

15. Disassemble Countershaft Assemblies.

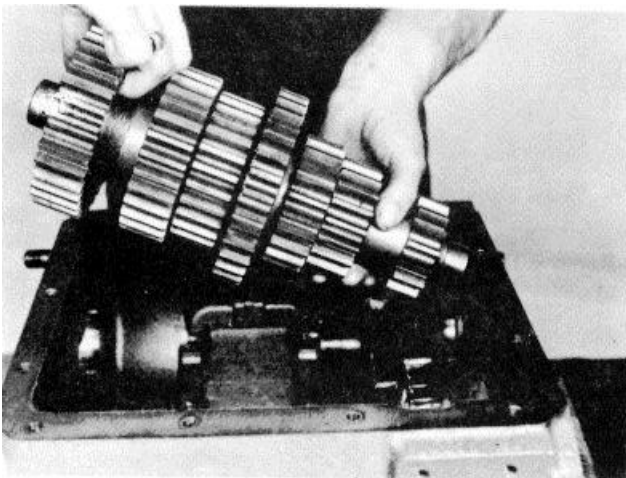
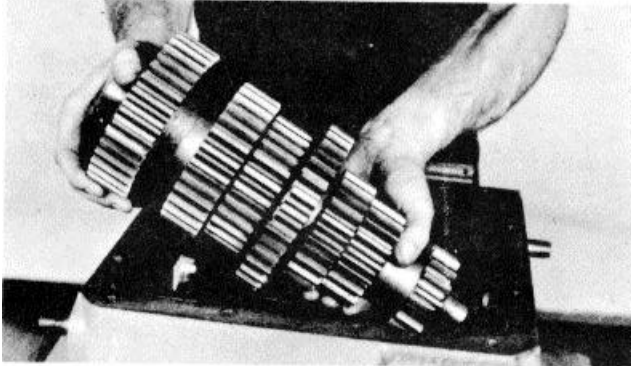

NOTE

SEE ILLUSTRATION 4-42 FOR EXPLODED VIEW OF COUNTERSHAFT ASSEMBLIES.

Remove the blocking and lift the right countershaft from the case.

Remove the left countershaft bearings in the same manner as those removed from the right and lift the left countershaft from the case.

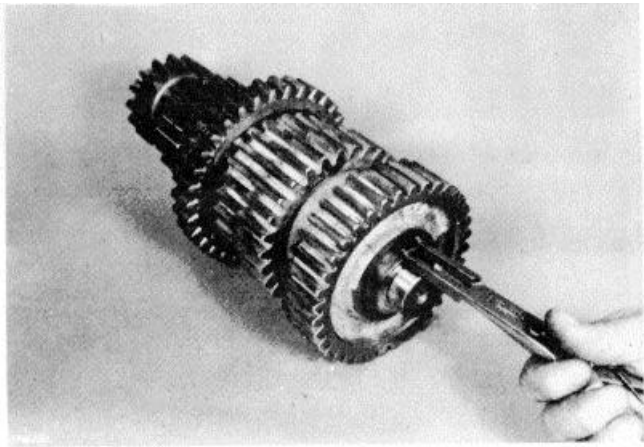

Remove the snap ring from the front of both countershafts.

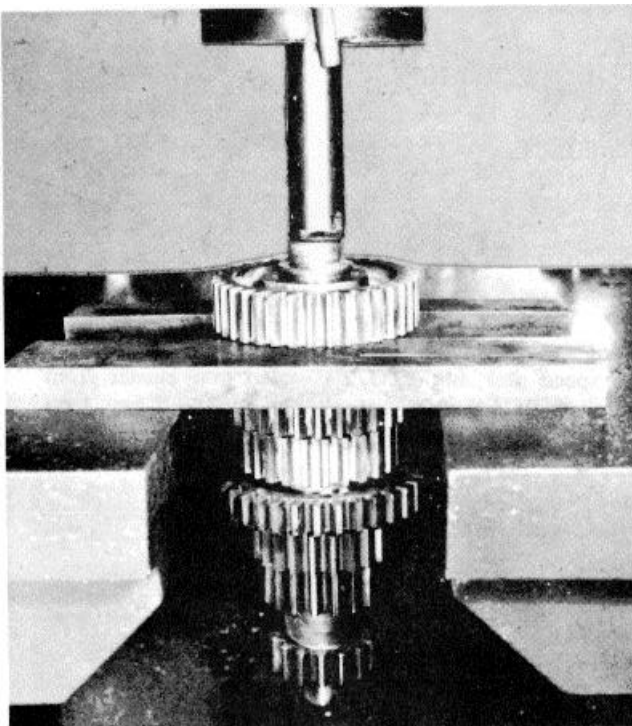

Press the drive gear from the shaft.

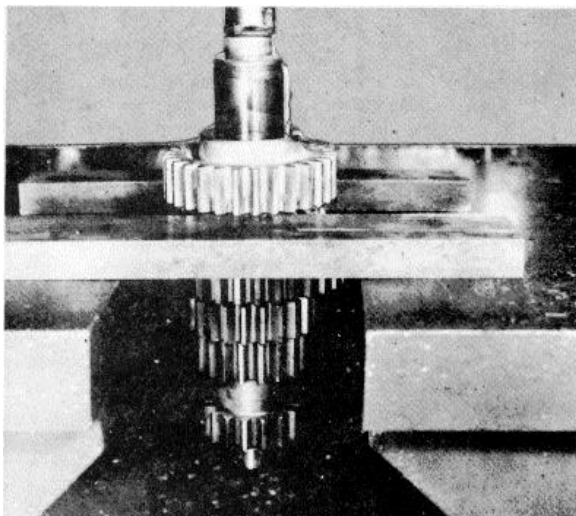

Press the 4th speed gear from the shaft.

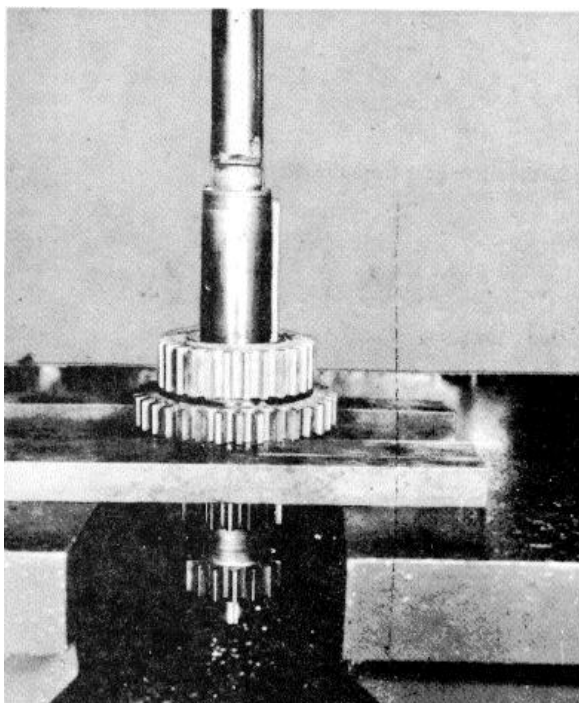

Using the rear face of the PTO gear as a base, press the 3rd speed gear and PTO/2nd speed gear cluster from the shaft. If necessary, remove the Woodruff key, long key and roll pin from the shaft.

NOTE

Countershafts are identical and disassembled in the same manner.

16. Remove the right reverse idler gear in the same manner as the left, as both are identical.

REASSEMBLY.

Make sure that interiors of case and housing are clean. It is important that dirt be kept out of transmission during reassembly. Dirt is abrasive and can damage polished surfaces of bearings and washers. Use certain precautions, as listed below, during reassembly.

1. GASKETS - Use new gaskets throughout the transmission as it is being rebuilt.. Make sure all gaskets are installed, as omission of gasket can result in oil leakage or misalignment of bearing covers. See "Location" of Gaskets heading.

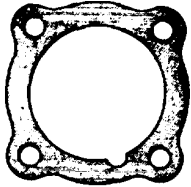

2. CAPSCREWS - To prevent oil leakage, use shellac on all capscrews. See torque rating chart for recommended torque.
3. O-RINGS - Lubricate all O-rings with "Dow Corning 200 Fluid," 50,000 cs.
4. ASSEMBLY - Refer to the disassembly illustrations as a guide to reassembly.
5. INITIAL LUBRICATION - Coat all thrust washers and splines of shafts with Lubriplate during installation to provide initial lubrication, preventing scoring and galling.
6. AXIAL CLEARANCES-Maintain original axial clearances of mainshaft forward speed gears of .005" to .011". Mainshaft reverse gear clearance is .011" to .032".

7. BEARINGS - Use of flanged-end bearing drivers is recommended for the installation of bearings. These drivers apply equal force to both races of bearings, preventing damage to balls and races and maintaining correct bearing alignment with shaft and bore. If tubular or sleeve type driver is used, apply force only to inner race.



8. UNIVERSAL JOINT COMPANION FLANGE - Pull the companion flange tightly into place with the mainshaft nut, using 450-500 foot-pounds of torque. Make sure the speedometer gear has been installed on yoke. If a speedometer gear is not used, a replacment spacer of the same width must be used. Failure to pull the yoke or flange tightly into place will permit the shaft to move axially with resultant damage to rear bearing.

1. Install Right Reverse Idler Gear.

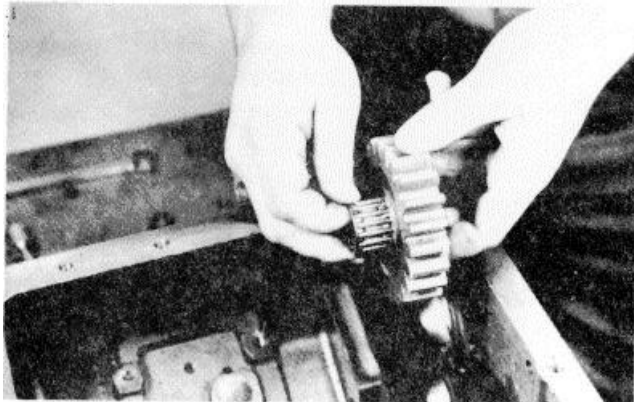

Install the needle bearing in the bore of the gear.

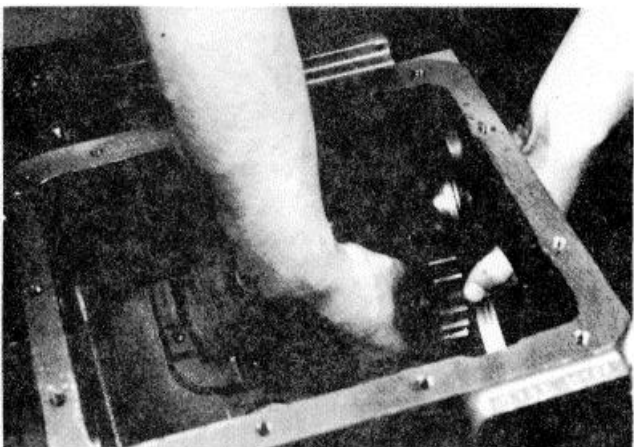

Slide the thrust washer into position on the rear of the case boss and hold the gear behind the washer.

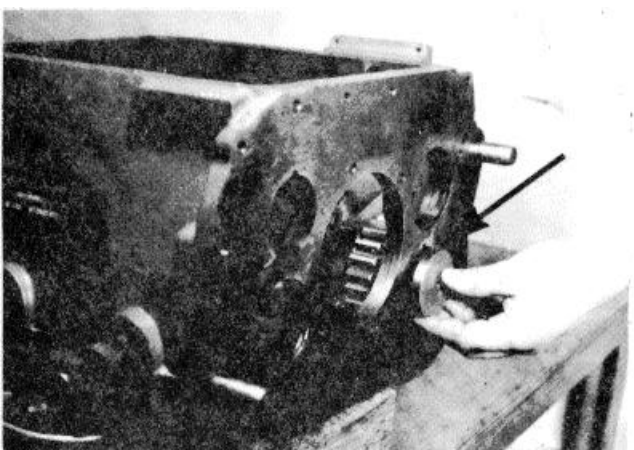

Make sure that the roll pin is in place in the large diameter of the idler shaft and insert the shaft through the gear, washer and boss, aligning the roll pin with the notch in the rear case bore.

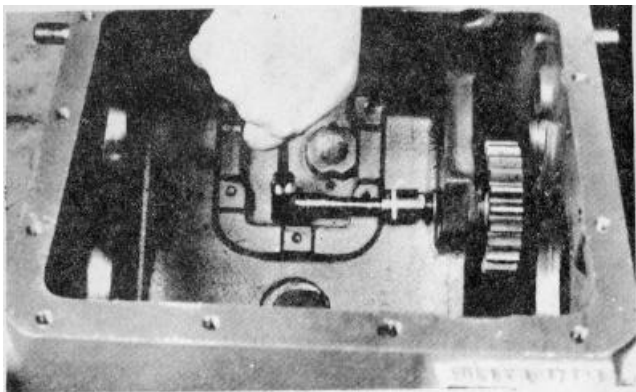

Secure the shaft with the washer and elastic stop nut.

2. Reassemble and Install Countershafts.

NOTE

COUNTERSHAFTS ARE IDENTICAL AND ASSEMBLED IN THE SAME MANNER.

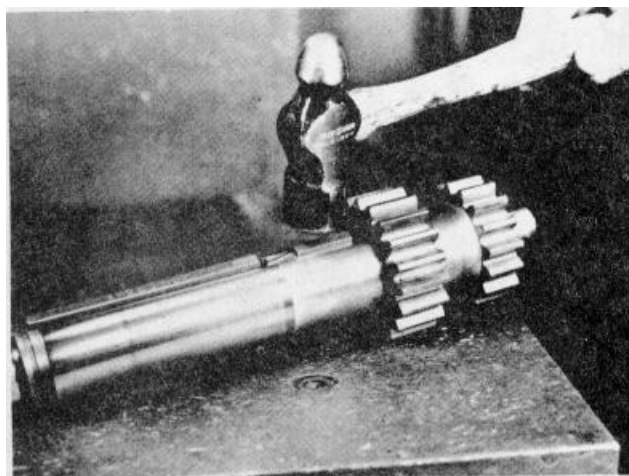

If previously removed, install the roll pin, long key and Woodruff key in the countershaft.

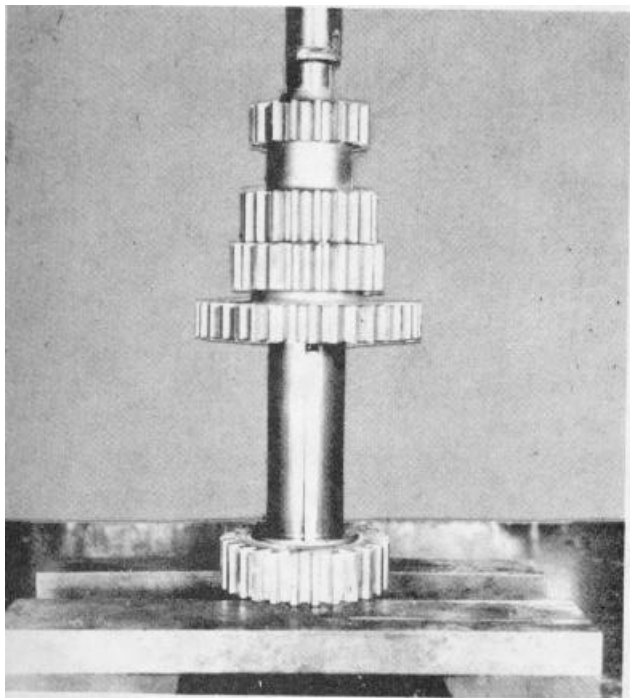

Press the PTO/2nd speed gear cluster onto the shaft.

NOTE

FOR RTO-613 MODELS, THE DRIVE GEAR AND 4TH SPEED GEAR LOCATIONS ARE REVERSED.

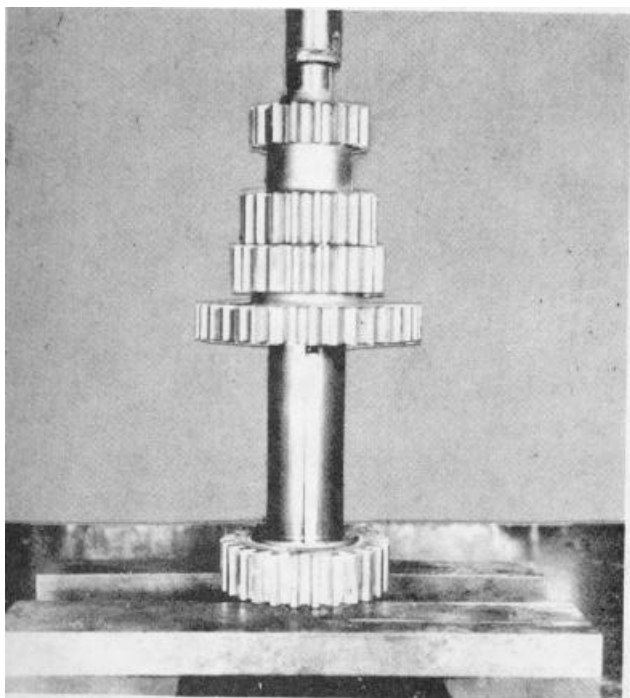

Press the 3rd speed gear onto the shaft with the long hub to the rear.

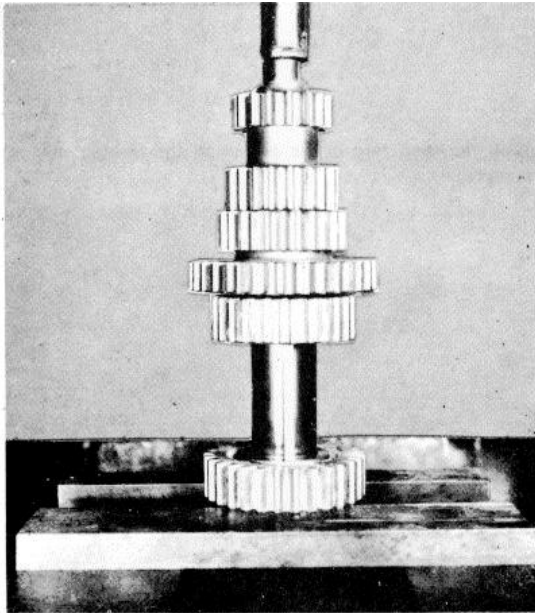

Press the 4th speed gear onto the shaft with the long hub to the front.

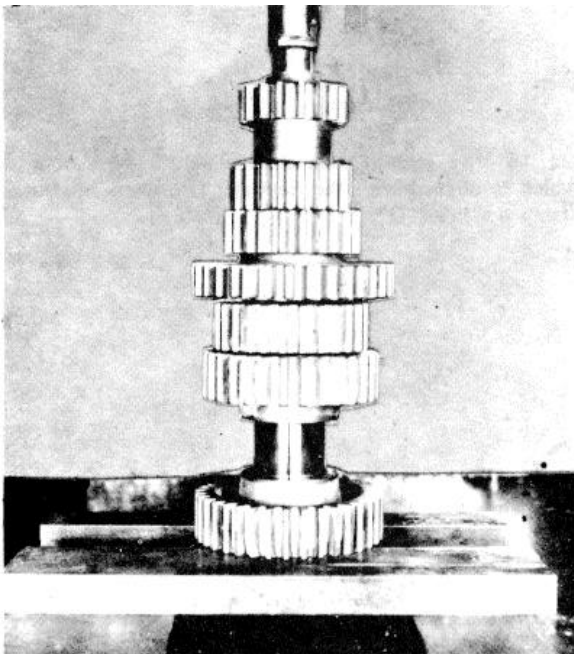

Press the drive gear onto the shaft with the long hub to the rear.

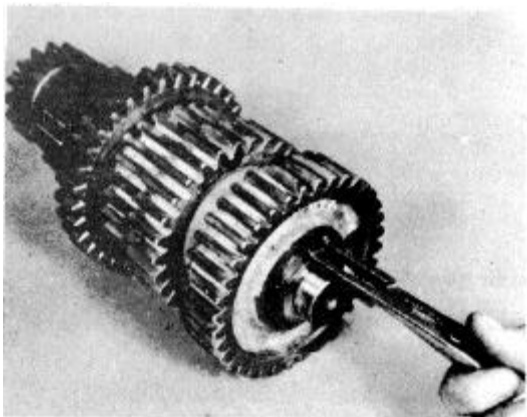

Install the snap ring in the groove in the front of the countershaft.

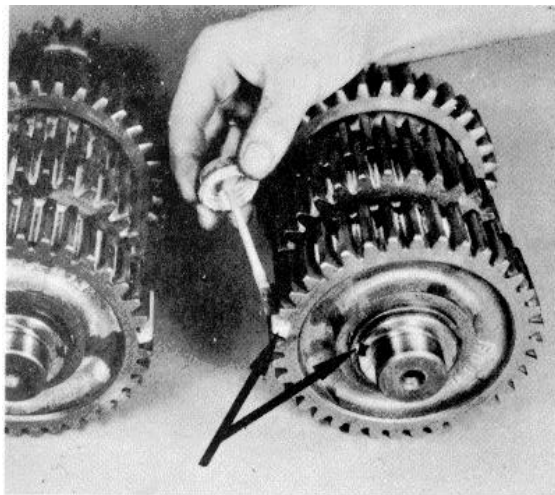

On the drive gear of each shaft mark the gear tooth which is aligned with the keyway. The tooth is also stamped with an "O".

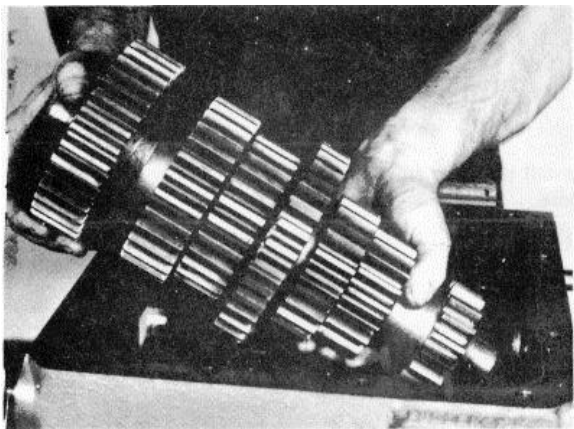

Place the left countershaft into position in the case.

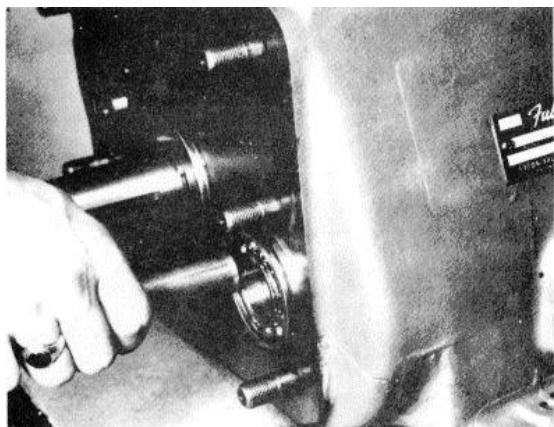

Center the rear of the countershaft in the case bore and partially install the front bearing on the shaft and in the case bore. Partially install the rear bearing.

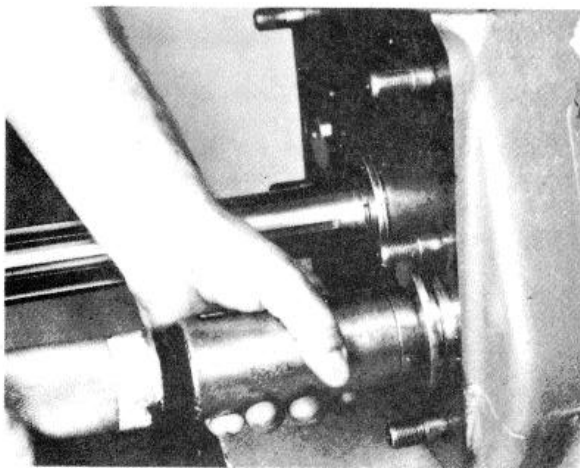

Use a bearing driver to complete installation of the front and rear bearings.

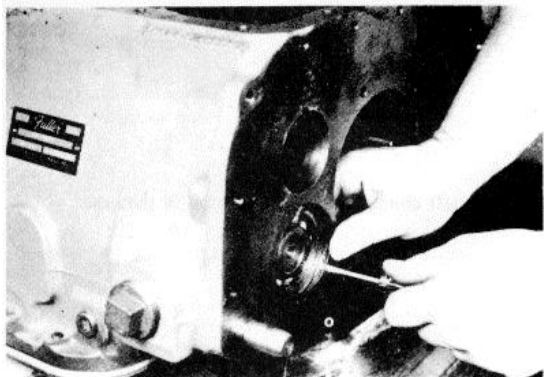

Install the snap ring in the groove in the rear bearing bore.

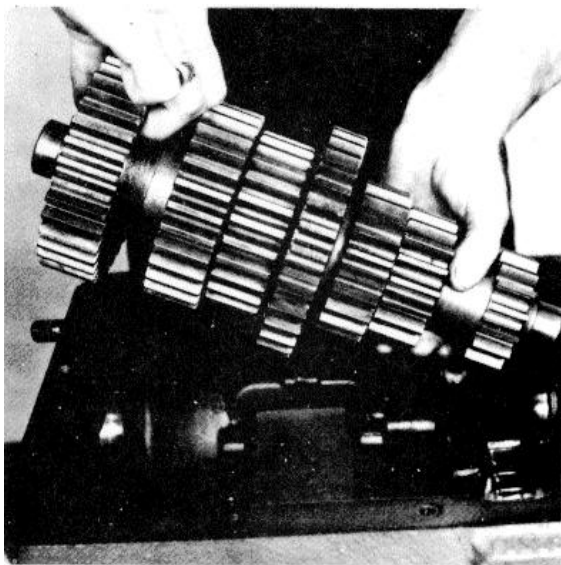

Place the right countershaft into position but DO NOT install the bearings.

3. Reassemble Mainshaft.

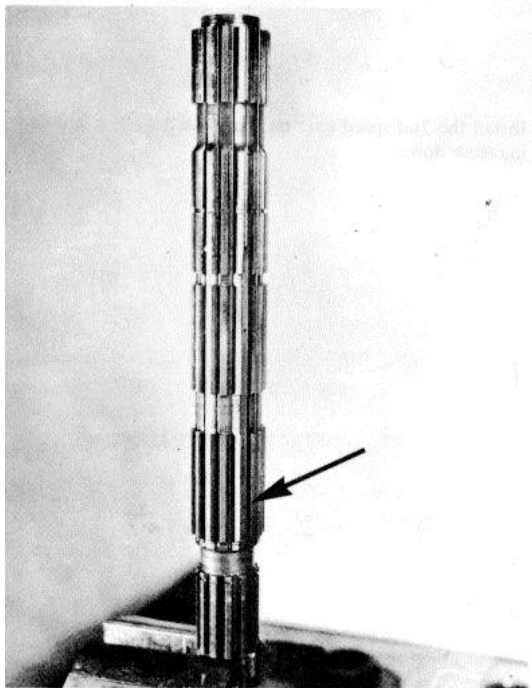

Place the mainshaft in a vise with the pilot (front) end down, keeping the keyway free for insertion of the key.

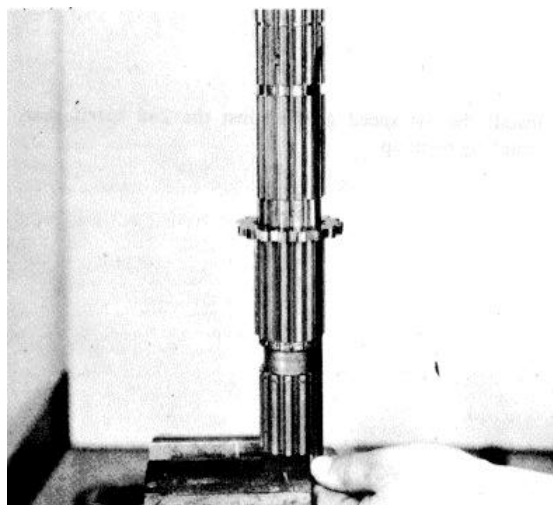

Install the 2nd speed gear washer at the 2nd speed gear location, inserting the key from the bottom to lock the washer in position.

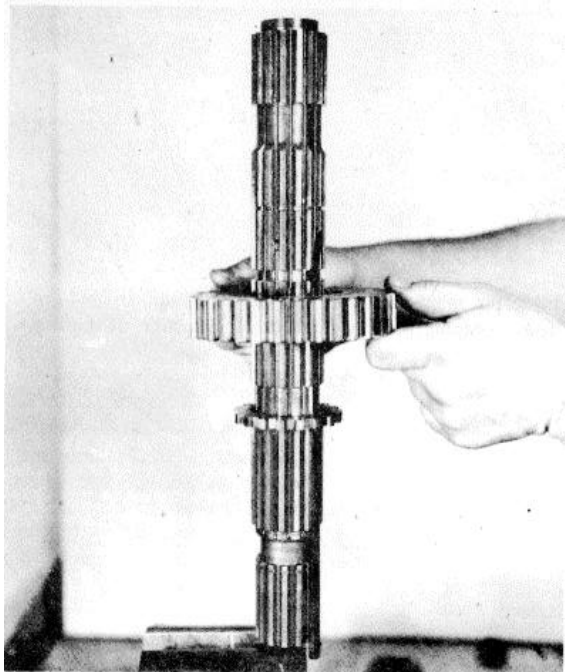

Install the 2nd speed gear on the splined washer, clutching teeth down.

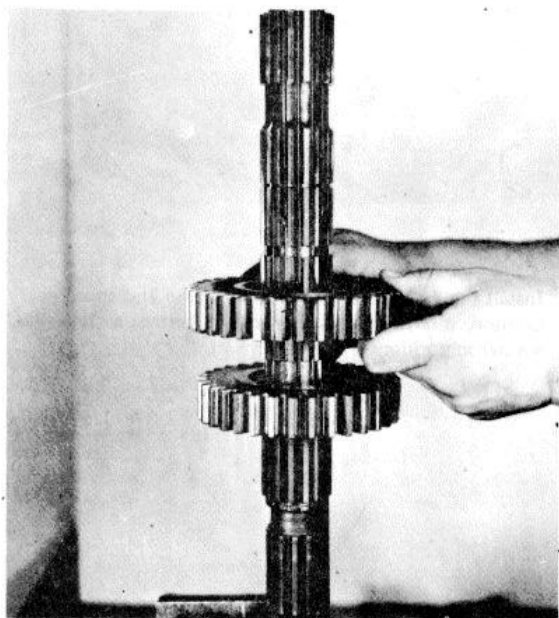

Install the 1st speed gear against the 2nd speed gear, clutching teeth up.

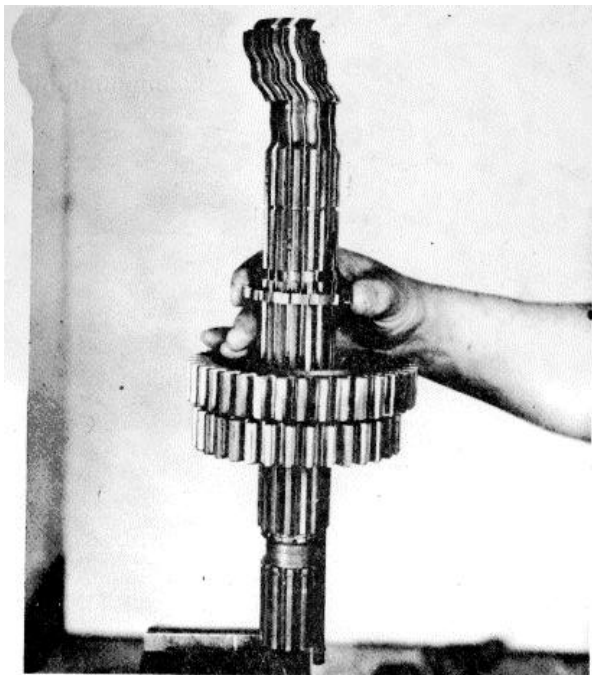

Insert the splined washer in the hub of the 1st speed gear. Align the washer with the mainshaft splines and move the key up to lock the washer in position.

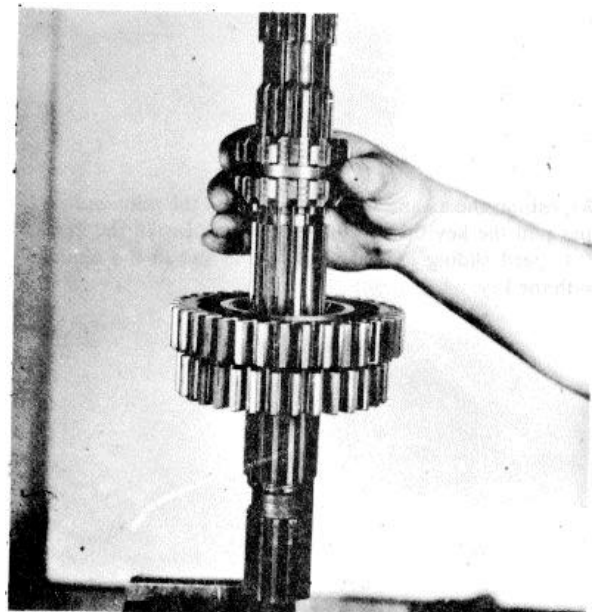

Install the 1st-reverse sliding clutch, aligning the slot in the clutch with the key.

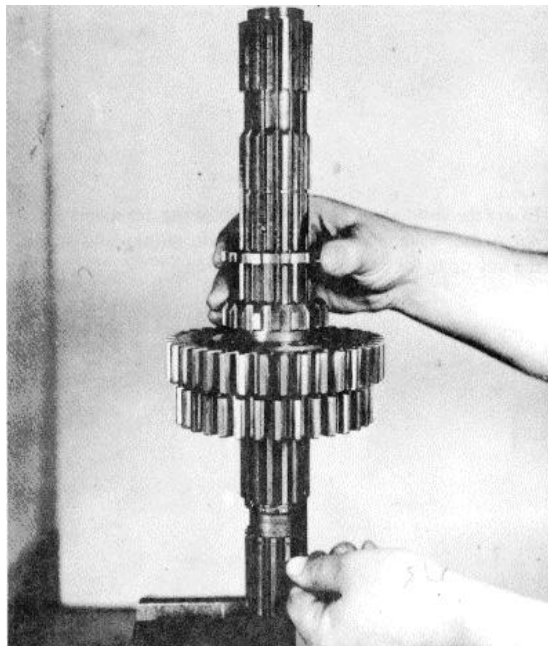

Install the reverse gear splined washer, align the keyway and lock in position with the key.

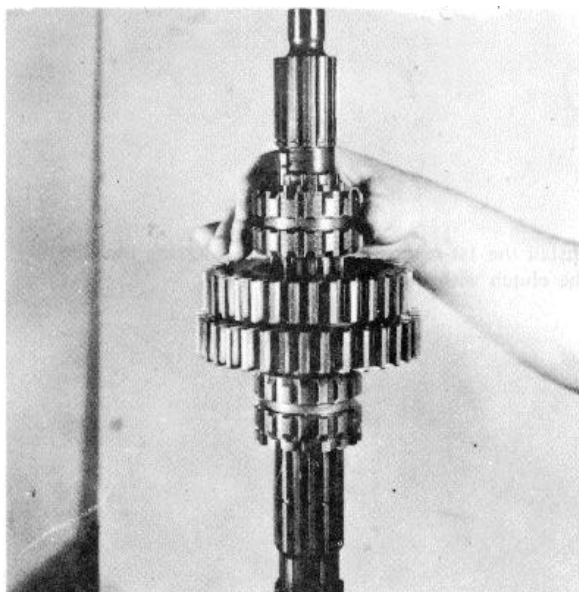

Reposition the assembly in the vise with the pilot end up' and pull the key up approximately 1/2". Install the 2nd- 3rd speed sliding clutch, aligning the slot in the clutch with the key.

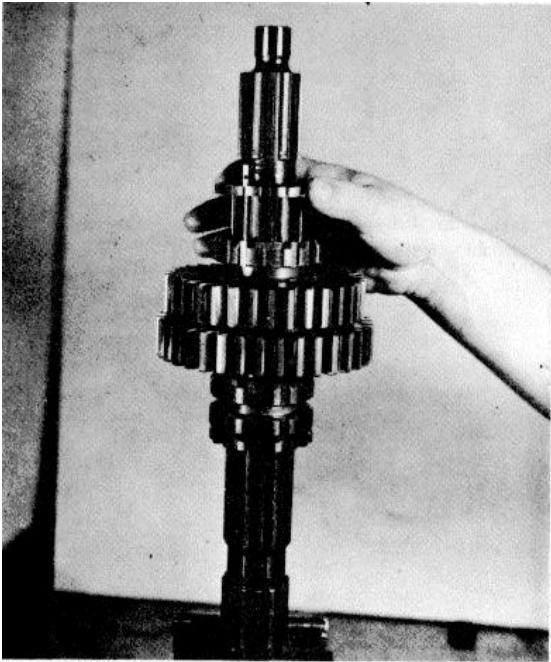

Slide the 3rd speed gear splined washer down over the key and push the key down into position, with the pin in the key resting on top of the washer.

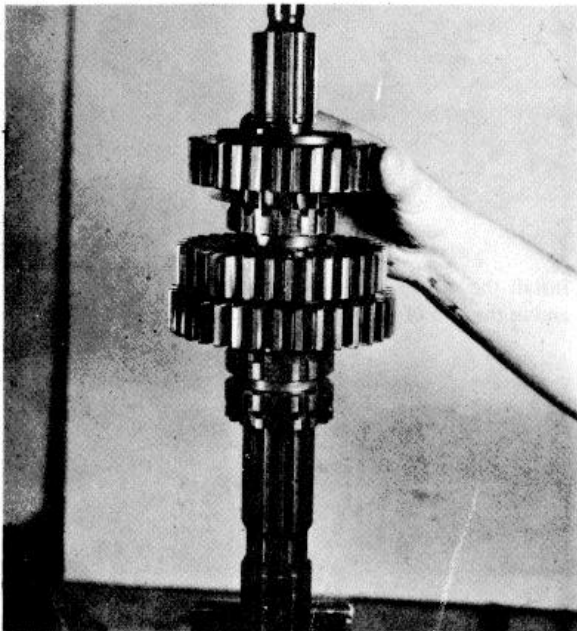

Install the 3rd speed gear on the splined washer, clutching teeth down.

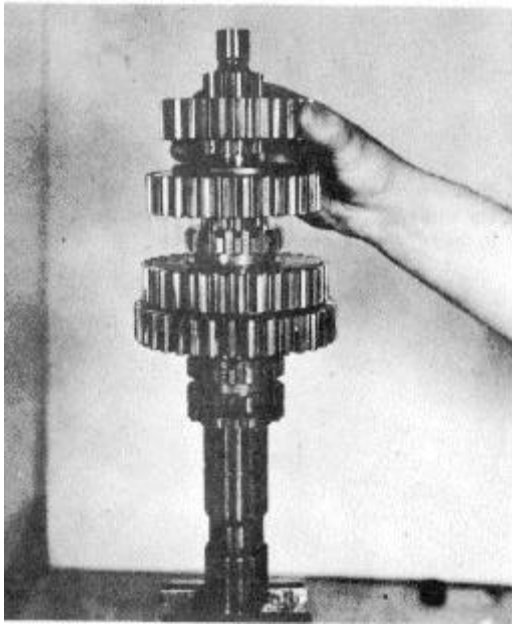

Install the 4th speed gear against the 3rd speed gear, clutching teeth up.

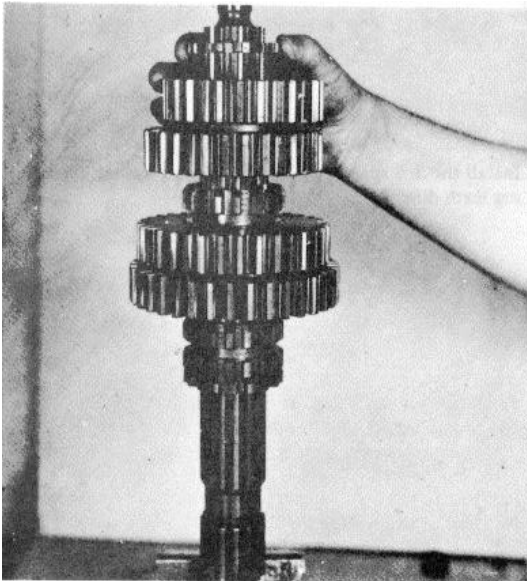

Install the 4th speed gear splined washer on the shaft and in the hub of the gear.

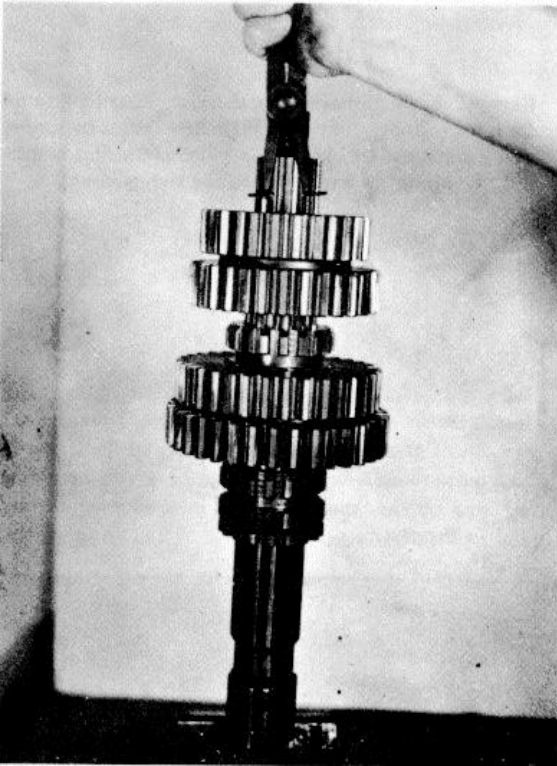

Install the snap ring in the groove in the mainshaft to secure the 4th speed gear splined washer.

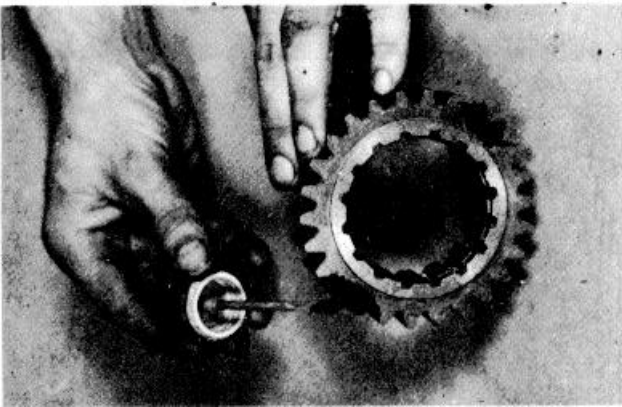

IMPORTANT: Mark two adjacent teeth on the drive gear and the two teeth directly opposite for timing purposes.

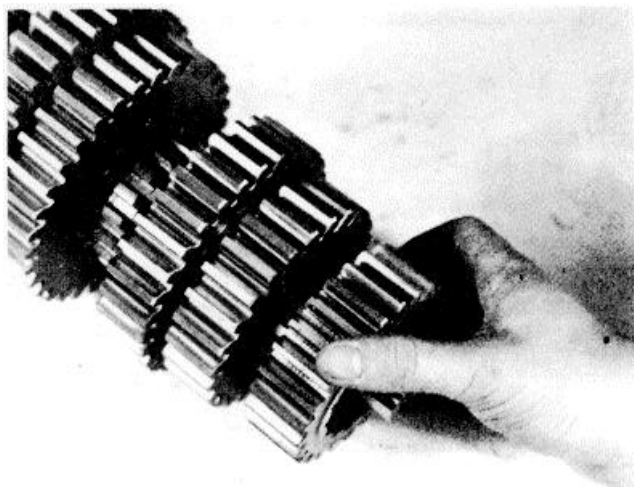

Remove the mainshaft from the vise. Install the 4th5th speed sliding clutch on shaft and install the drive gear against the 4th speed gear, clutching teeth towards the 4th speed gear and engaging the sliding clutch.

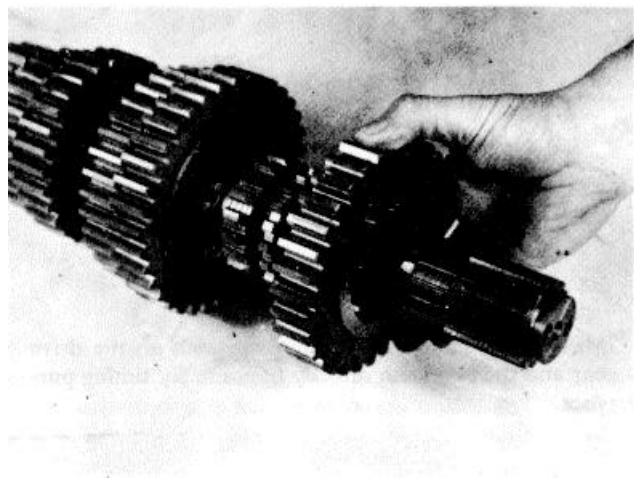

Place the reverse gear on the splined washer which is locked to the shaft.

4. Install Mainshaft Assembly.



Block the right countershaft against the wall of the case and place the mainshaft into position, meshing gears with those of the left countershaft.

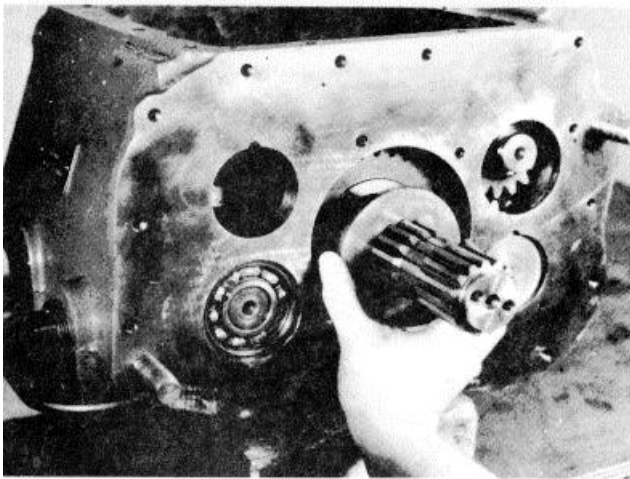

Install the reverse gear washer, flat side to the rear.

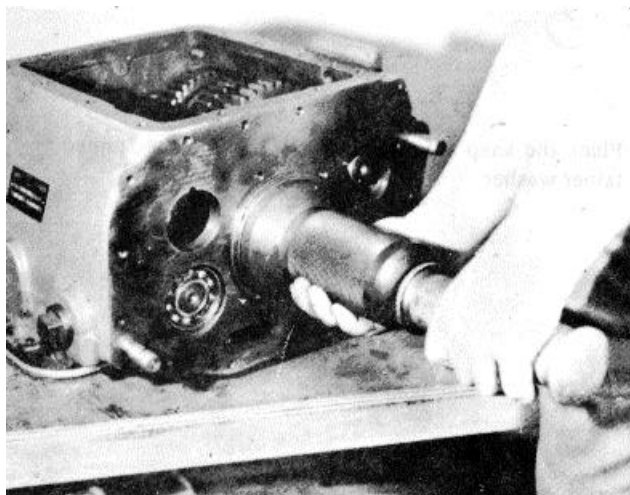

Seat the mainshaft rear bearing in the case bore.

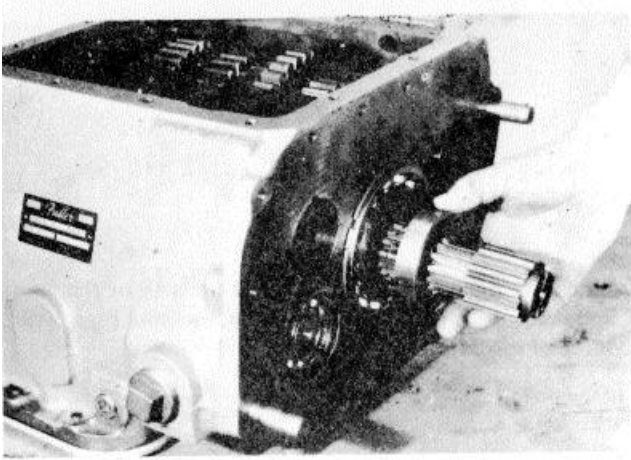

Install the six springs in the centering ring using a small amount of grease or equivalent in each of the centering ring bores to hold the springs in place. Place the centering ring on the shaft and slide into the rear bearing against the reverse gear washer.

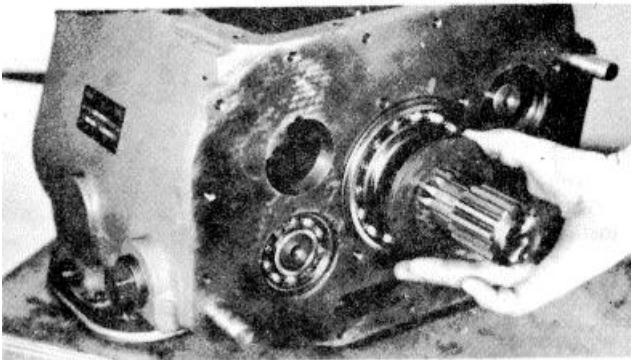

Install the splined retainer washer on the shaft, cone surface towards the centering ring.

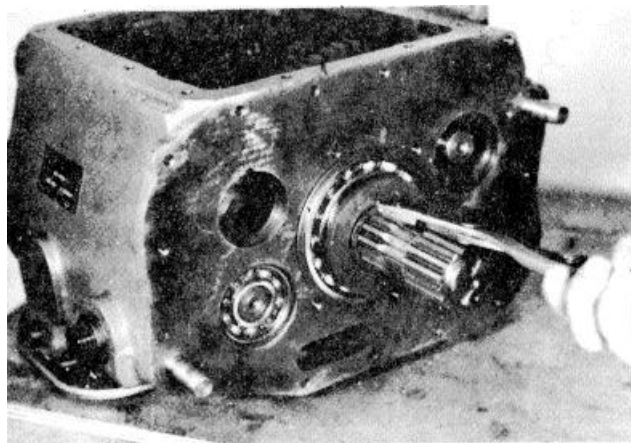

Place the snap ring on the shaft against the splined retainer washer.

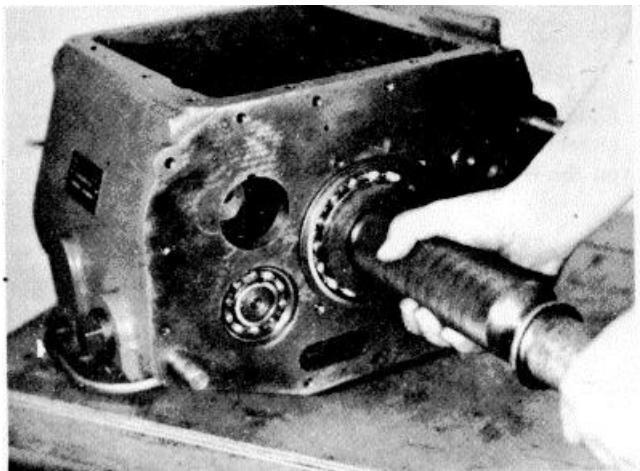

Block against the front of the mainshaft and use a sleeve driver to move the centering ring, retainer washer and snap ring forward until the snap ring seats in the groove in the mainshaft.

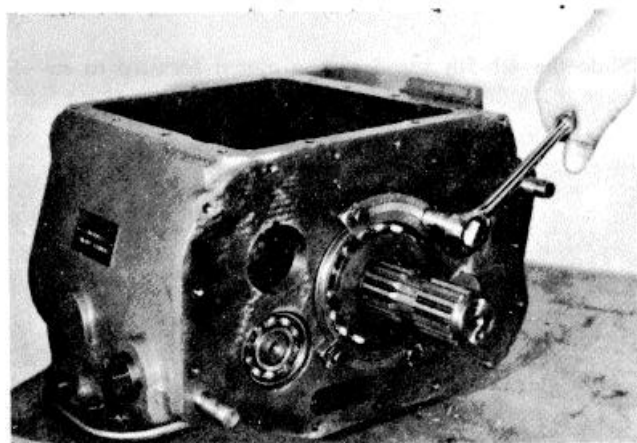

Install the rear bearing retainers and secure the cap screws with the locking lugs.

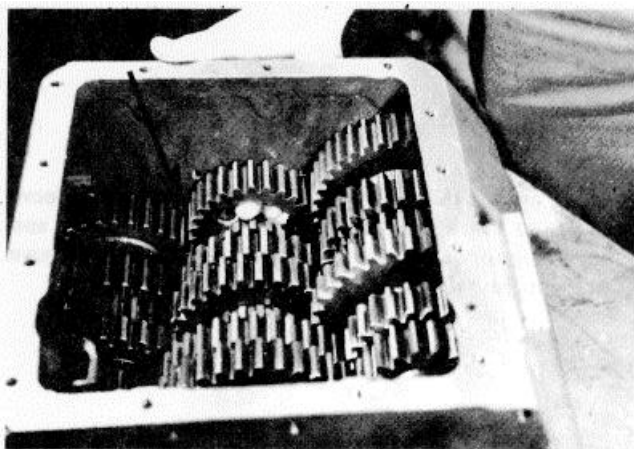

Slide the drive gear forward off the splines of the sliding clutch and align the timing marks with the marked tooth on the left countershaft.

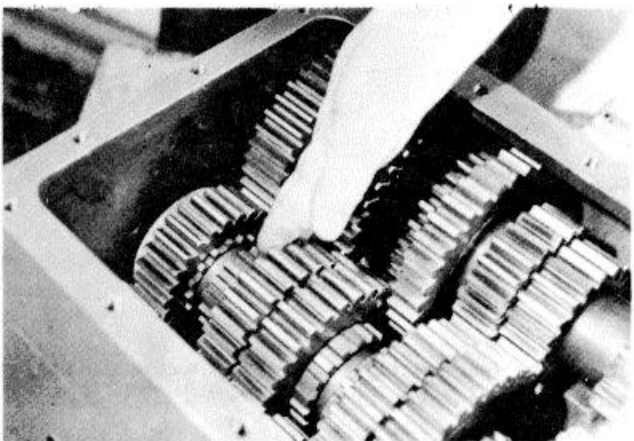

Slide the 4th-5th speed sliding clutch forward to engage the splines of the drive gear.

5, Install Clutch Shaft.

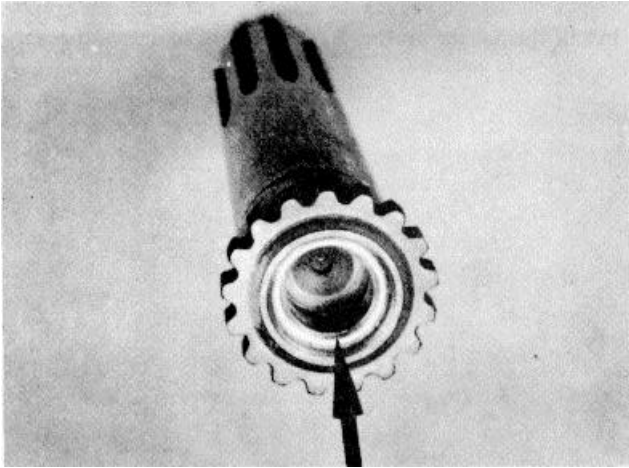

If previously removed, install bushing in pocket of clutch shaft; install flush with shaft, making sure that oil hole in shaft is not plugged.

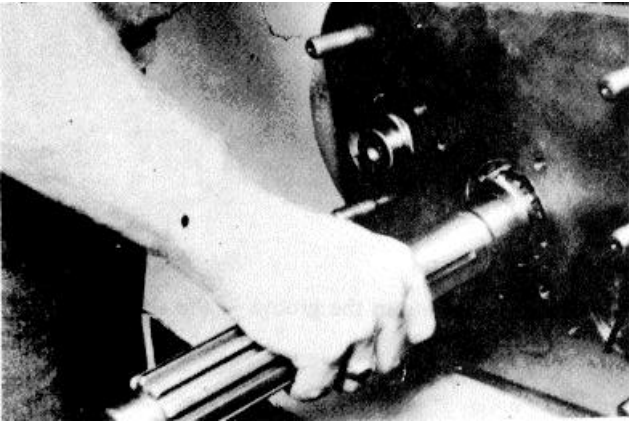

Insert the clutch shaft into the drive gear.

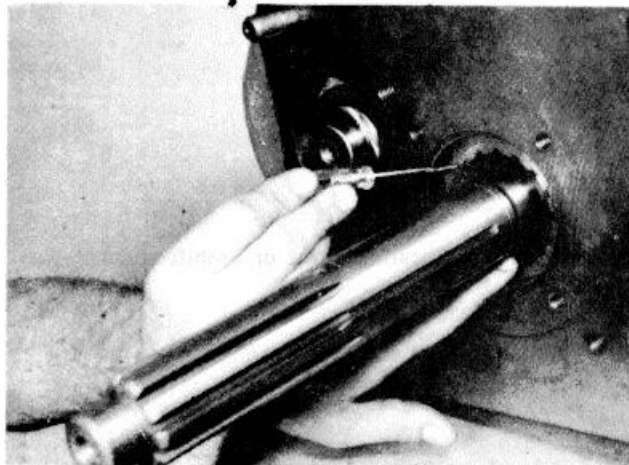

Install the snap ring in the inner diameter of the drive gear.



Install the spacer on the shaft, flat side against the gear.

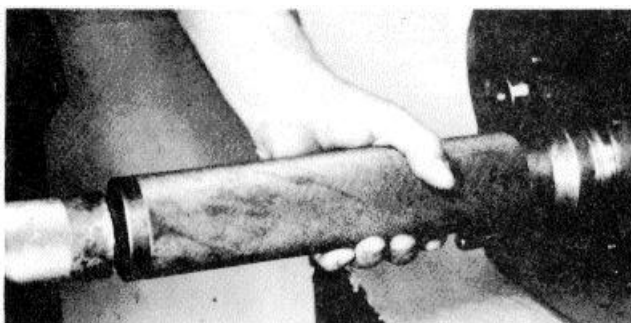

Install the drive gear bearing on the shaft and in the case bore.

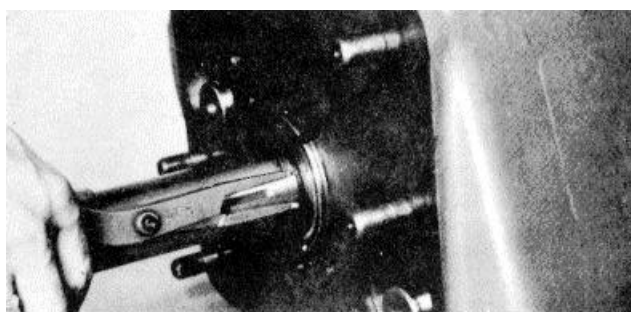

Install the snap ring in the groove in the shaft, flat side towards the bearing.

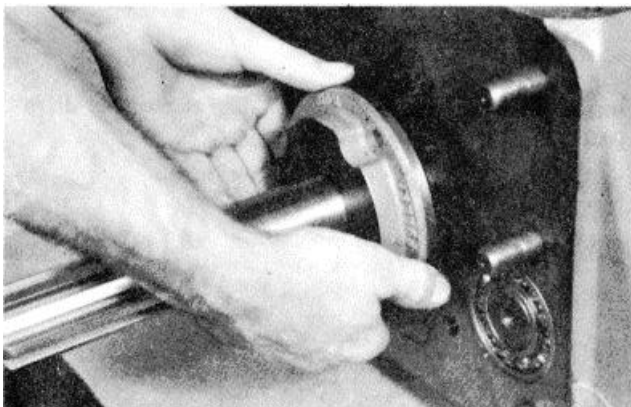

Install the front bearing cover or upshift clutch brake.

6. Install Right Counter Shaft Bearings.

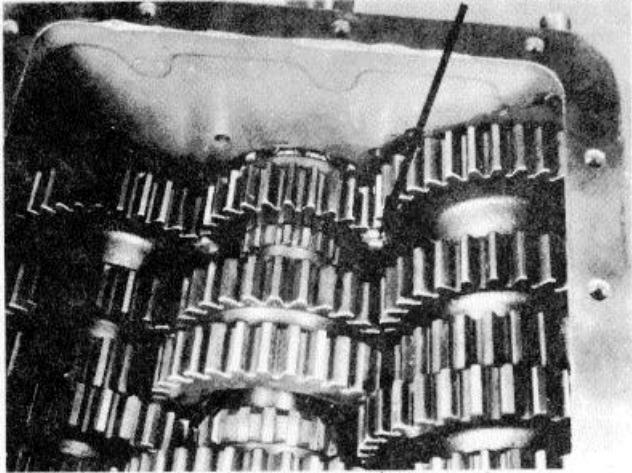

Engage the timing tooth on the right countershaft between the two marked teeth on the drive gear, ensuring that the left countershaft is still in time.

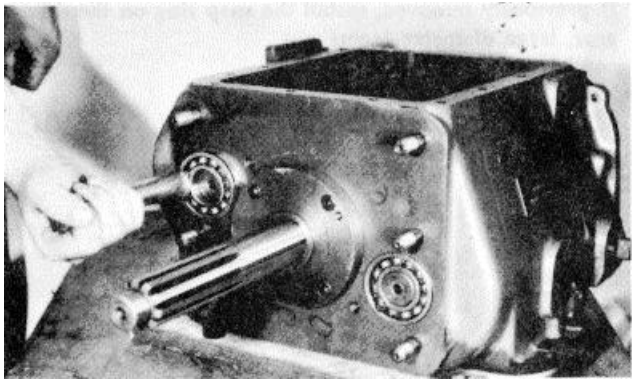

Center the rear of the shaft in the bore and partially install the front bearing. Partially install the rear bearing.

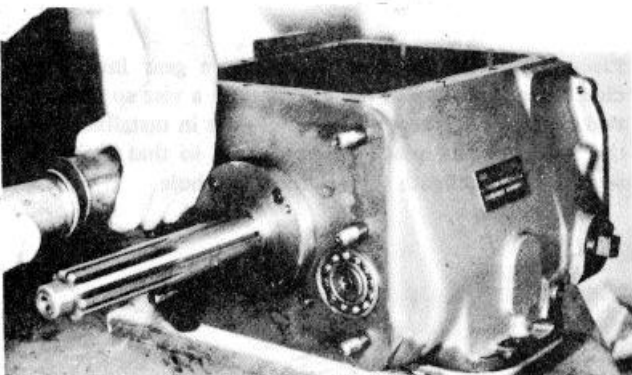

Use a bearing driver to complete the installation of the bearings.

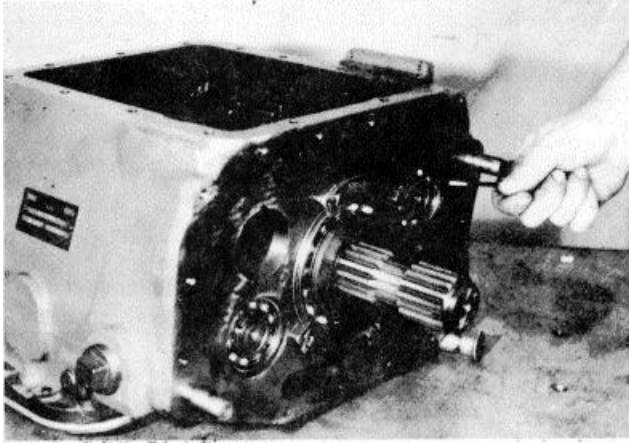

Install the snap ring in the groove in the rear countershaft bearing bore. Drive both countershafts back until the rear bearings seat against the snap rings.

7 Reassemble Auxiliary Drive Gear/Clutch Assembly.

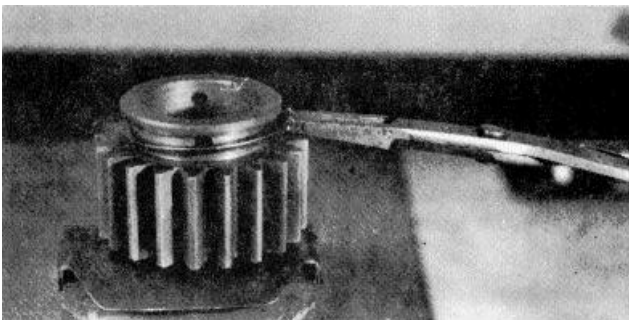

If previously removed, install the snap ring on the drive gear, large diameter facing out.

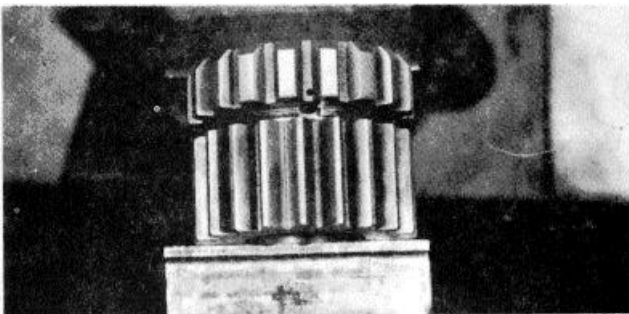

Place the small diameter of the drive gear inside the clutch gear and mount the assembly in a vise so that the two gears are forced together. For ease in installation of the retaining pin, place the snap ring so that the open section is underneath the retaining pin hole.

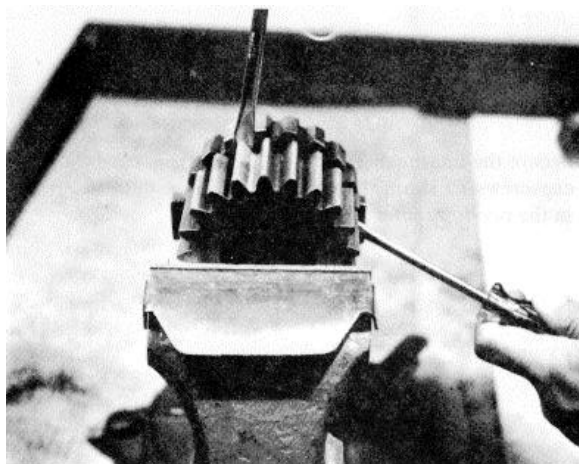

Use two screwdrivers to pry the snap ring into position inside the clutch gear.

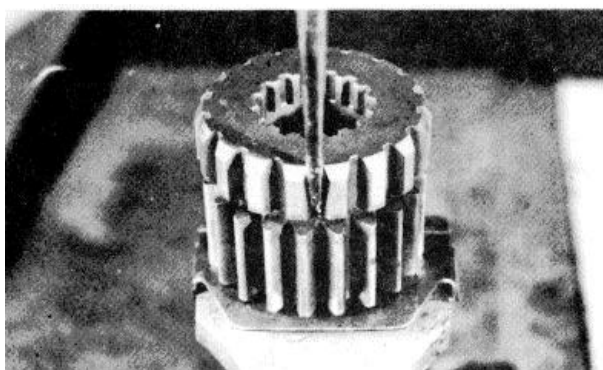

Align one of the holes in the drive gear with the retaining pin hole and insert the pin from inside the drive gear into place in the pin hole with the elbow bend facing away from the clutch gear. Turn the drive gear so the pin cannot fall out. Use a hammer and punch to bend the end of the retaining pin down in between the teeth of the clutch gear.

8. Reassemble Intermediate Section.

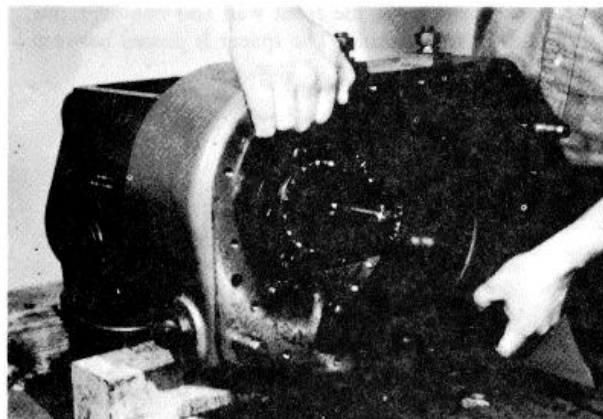

Place the intermediate housing on the dowel pins and against the front case.

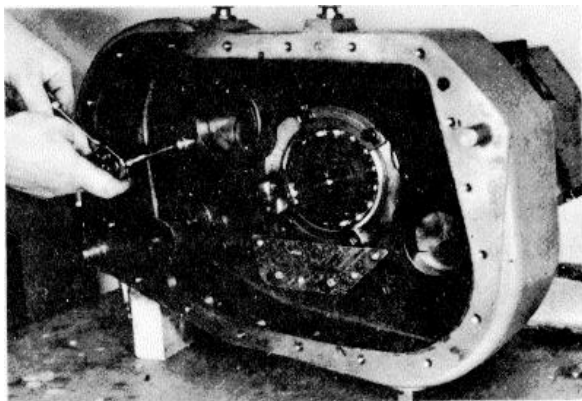

Secure the intermediate housing to the front case with 13 capscrews (9 short, 4 long.) DO NOT install capscrews in the two top center holes.

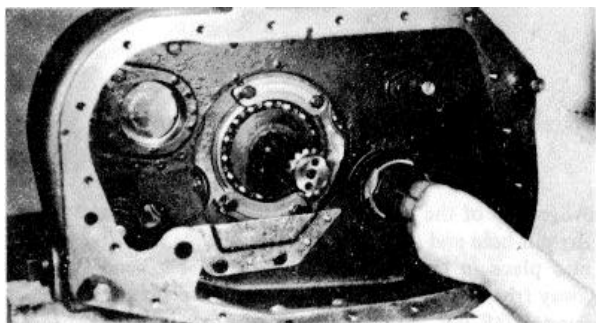

Place a snap ring spacer in both front auxiliary countershaft bearing bores.

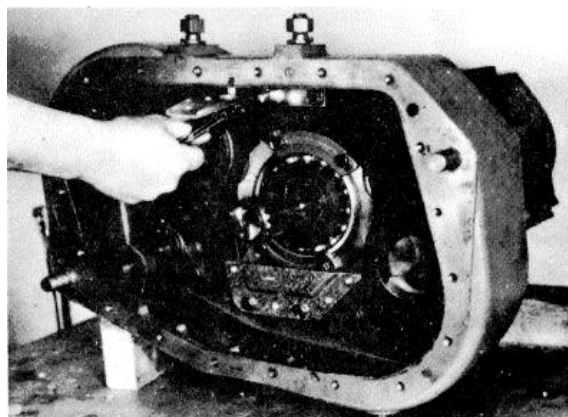

Install the metal oil trough in the intermediate housing with two capscrews in the front wall and one capscrew in the top of the housing. The spacer is placed between the oil trough and the top of case.



IMPORTANT: Mark the low speed gear tooth identified with an "O" on each auxiliary countershaft for timing purposes. Then mark the tooth on the intermediate and drive gears which align with this tooth. If previously removed, install the bearing on the front of each countershaft, seating against the shaft shoulder.

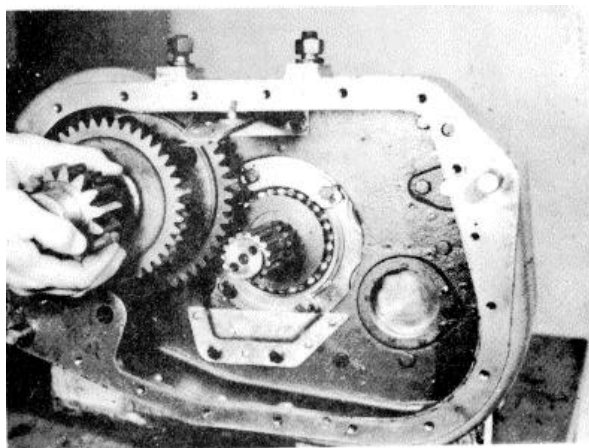

Place the left countershaft into position, but do not completely seat the front bearing in the bore.

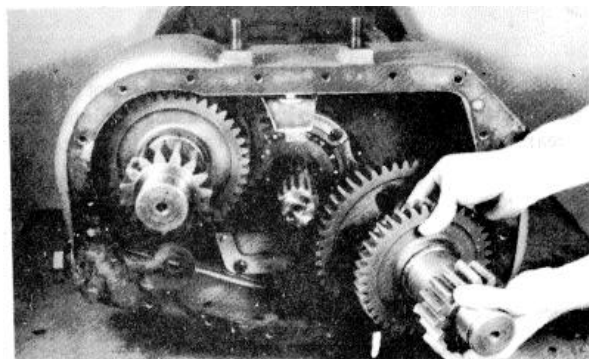

Place the right countershaft into position, but do not completely seat the front bearing in the bore.

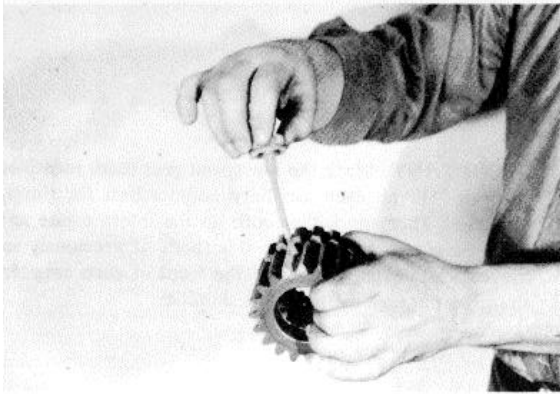

On the auxiliary drive gear and sliding clutch assembly mark two adjacent teeth on the drive (larger width) gear and mark the two teeth directly opposite.

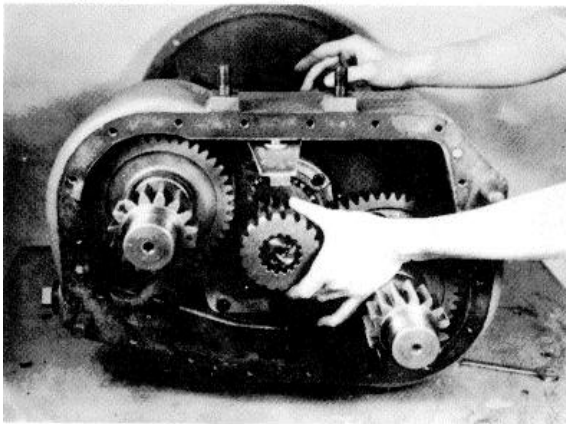

Install the auxiliary drive gear and sliding clutch assembly on the splines of the mainshaft, aligning both sections with the splines. Mesh the marked tooth on each countershaft between the marked teeth of the auxiliary drive gear.

NOTE
KEEP THE MARKED TEETH ON THE COUNTERSHAFTS PARALLEL.

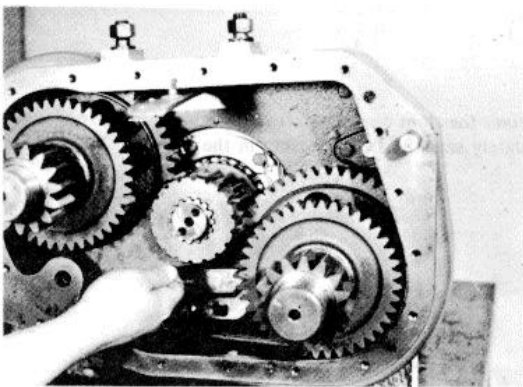

Place the intermediate shift yoke in the yoke slot of the auxiliary drive gear/sliding clutch assembly, hub to the rear.

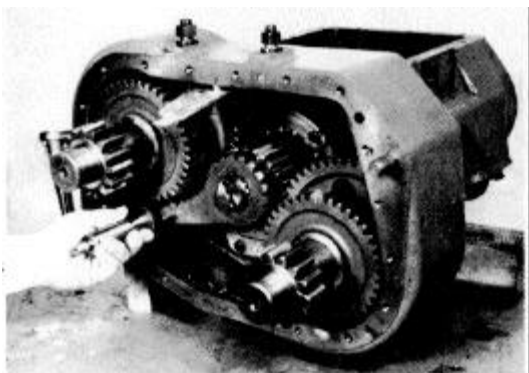

11. Install the intermediate shift shaft through the bore in the housing and the yoke hub. Secure with the lockscrew and wire.

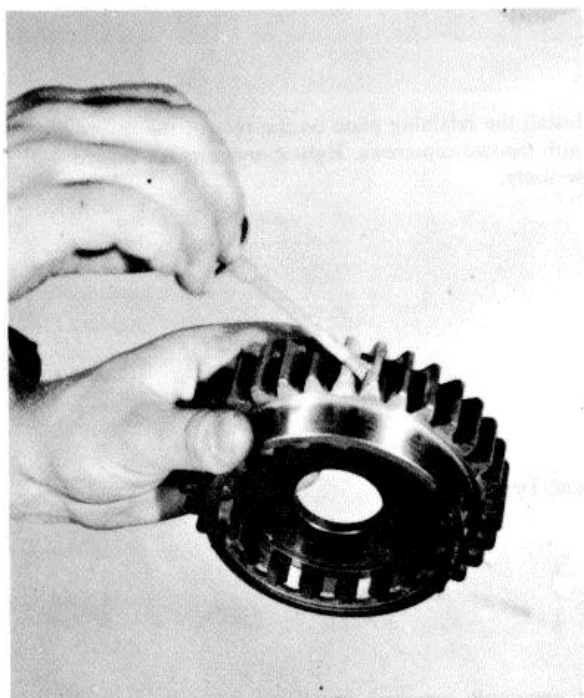

12. If previously removed, install the snap ring, plate, and second snap ring in the inner diameter of the intermediate drive gear, noting that the raised side of the plate faces towards the clutching teeth of the drive gear. Mark two adjacent teeth on the gear and the two teeth directly opposite.

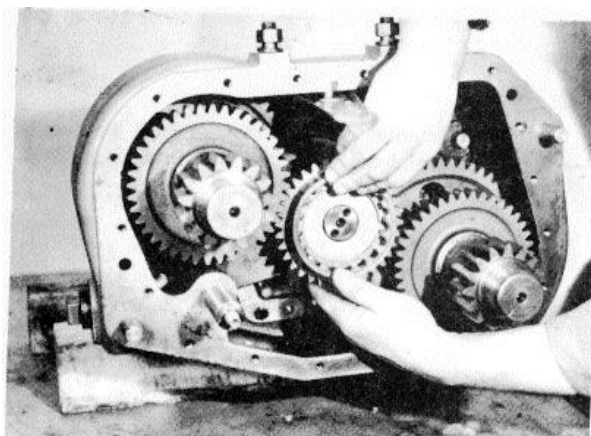

Place the drive gear on the rear of the mainshaft, meshing the marked tooth on each countershaft between the marked teeth on the drive gear.

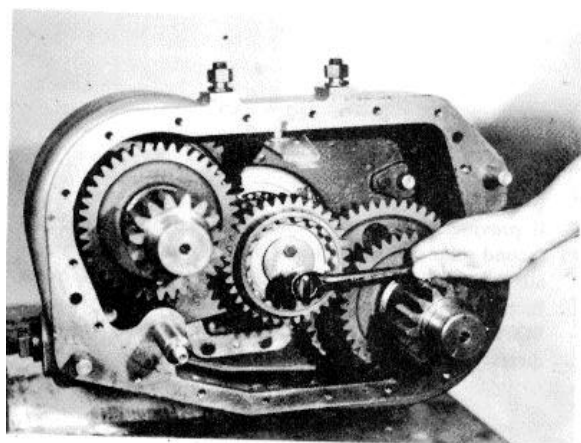

Install the retaining plate on the rear of the mainshaft with the two capscrews. Tighten and wire the capscrews securely.

9. Reassemble Tailshaft and Rear Bearing Assembly.

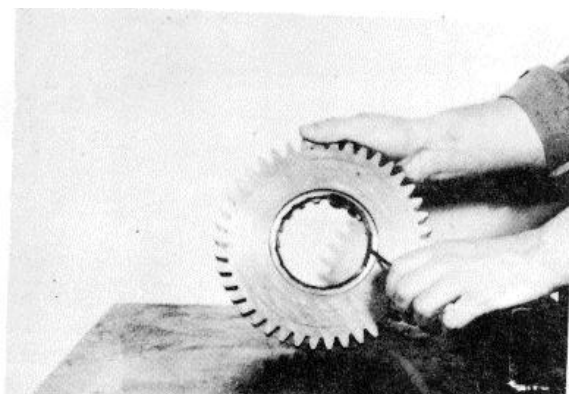

If previously removed, install the snap ring in the low speed gear.

NOTE

FOR TIMING PURPOSES, MARK TWO ADJACENT TEETH ON THE LOW SPEED AND MARK THE TWO TEETH DIRECTLY OPPOSITE.

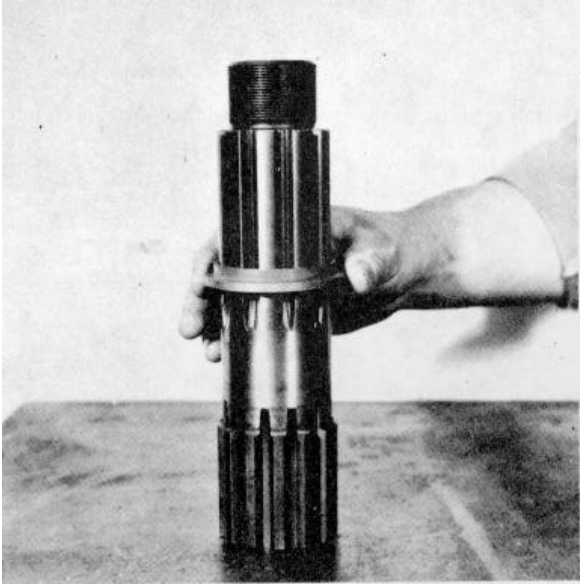

Set the tailshaft on a bench with the threaded end up and install the low speed gear stepped washer, large diameter down.

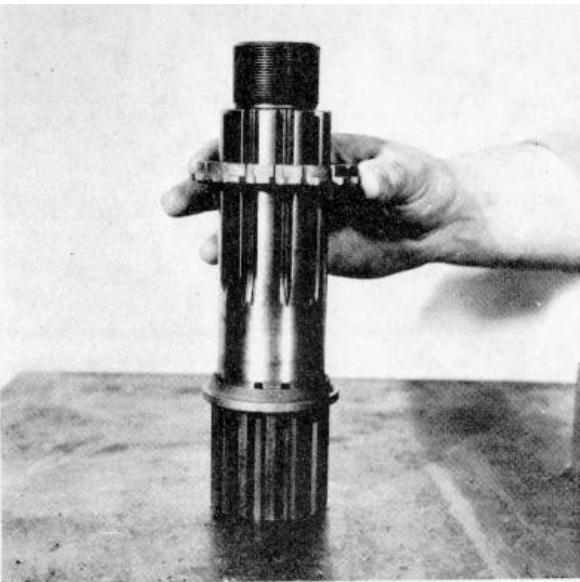

Install the splined spacer onto the shaft and washer.

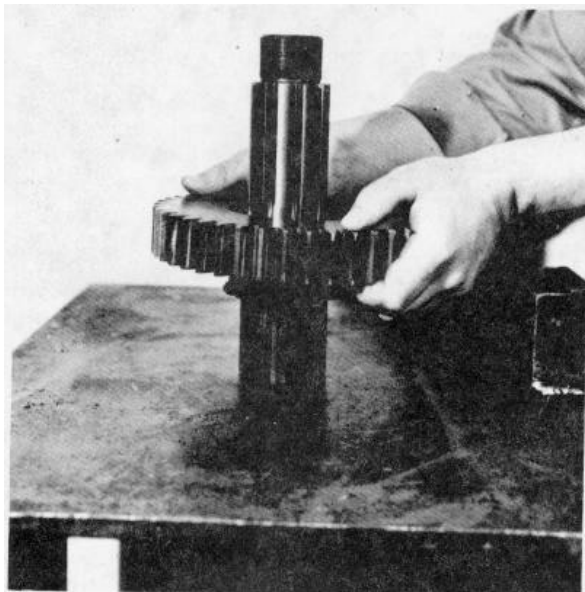

Install the low speed gear on the splined spacer, clutching teeth down.

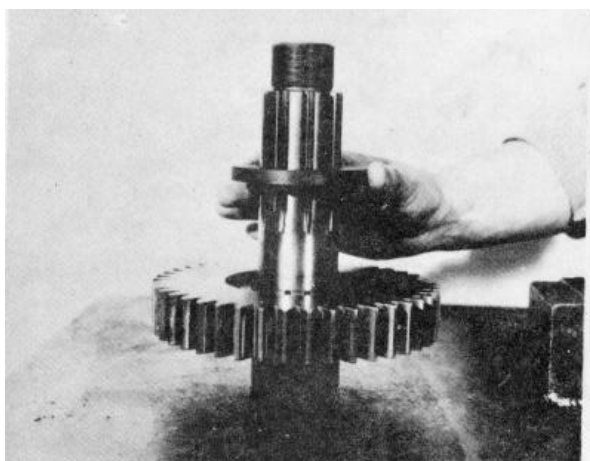

Install the low speed gear rear washer on the shaft, chamfered ID up.

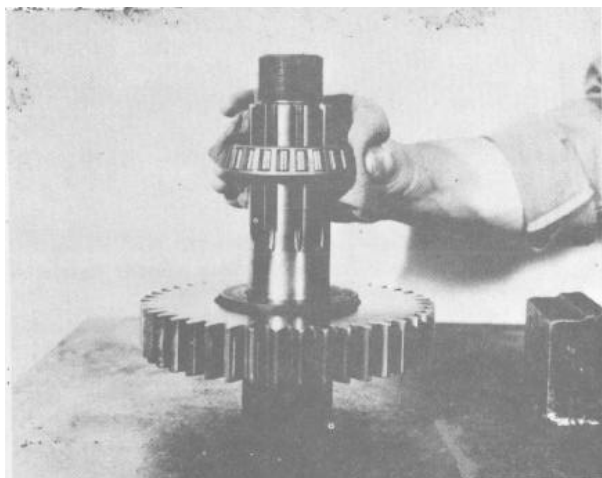

Install the front cone of the rear bearing on the shaft and against the washer. (Heating of the bearing will facilitate installation. Use heat lamps but do not heat over 275° F.)

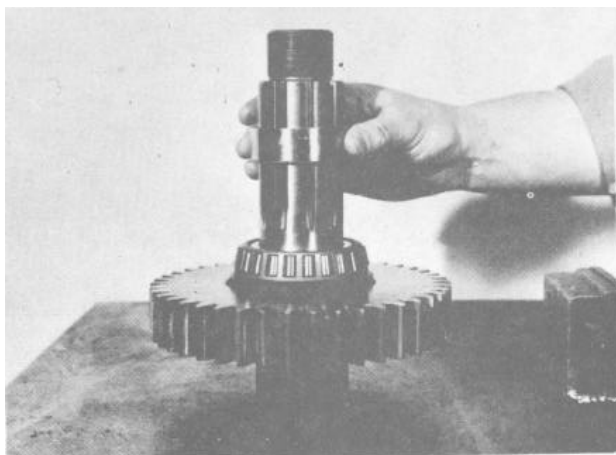

Install the bearing inner spacer on the shaft.

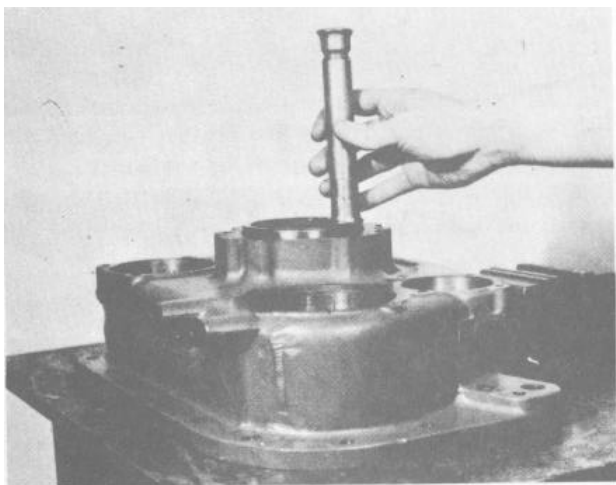

Place the front bearing cup partially into the bore of the housing, taper to the inside.

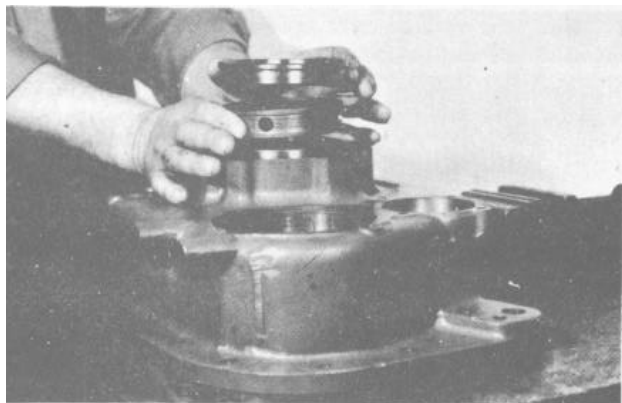

Place the bearing outer spacer on the front cup and place the rear bearing cup on the spacer.

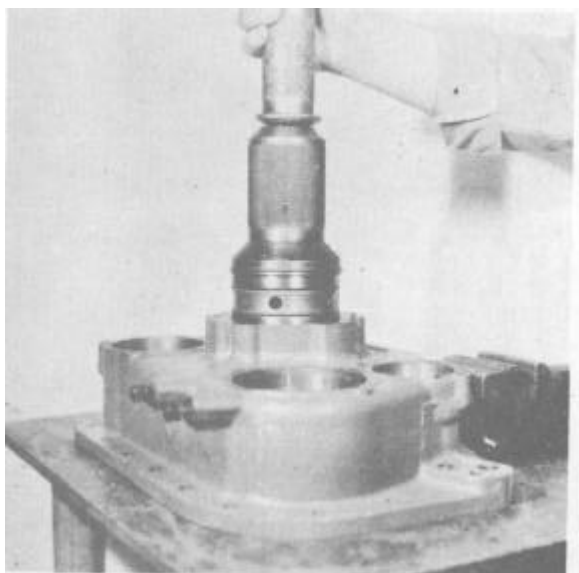

Tap all three units evenly into the rear bore until the lip of the rear cup seats against the housing.

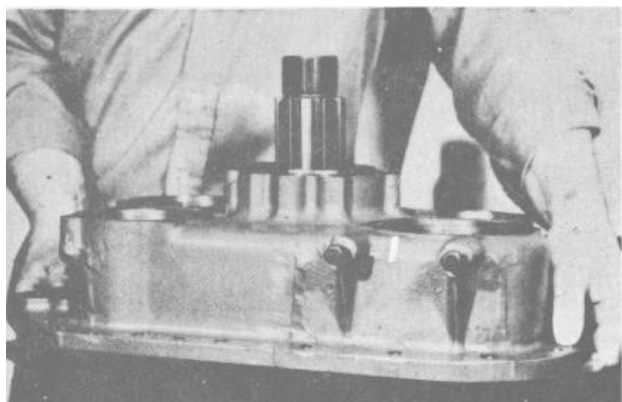

Place the auxiliary rear housing over the end of the shaft and seat the front bearing cone in the front cup.

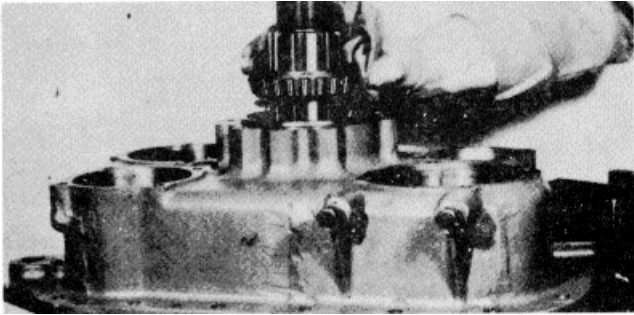

Install the bearing rear cone on shaft and into the rear up. (Heating of the bearing cone will facilitate installation, but do not heat over 275° F.)

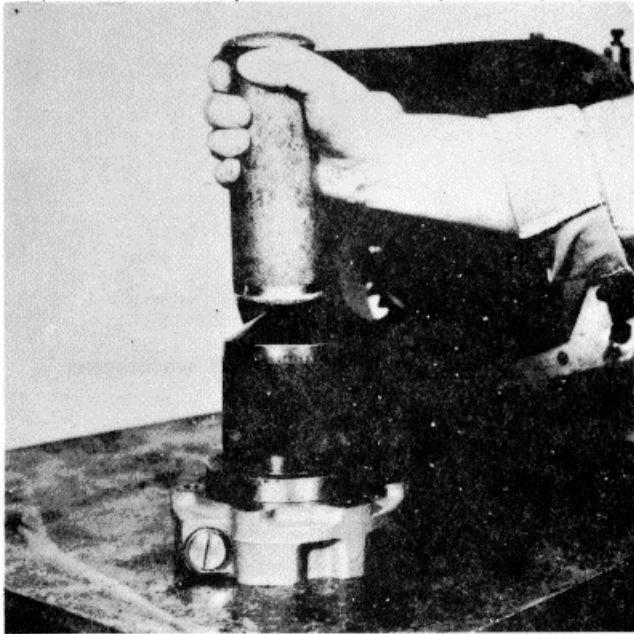

Install the oil seal in the rear bearing cover.

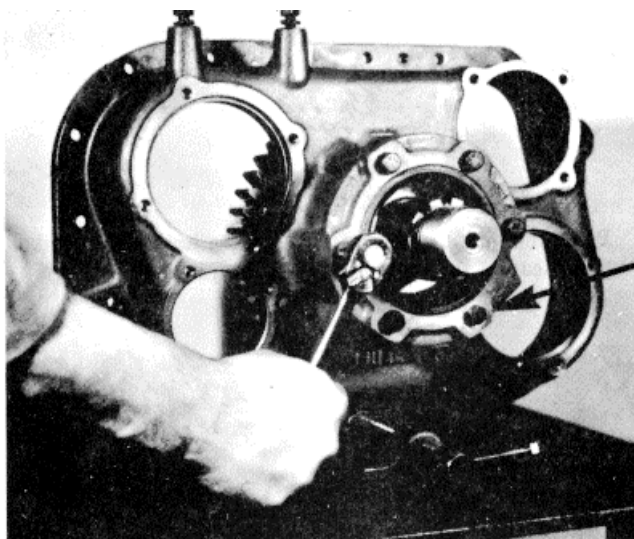

Install the rear bearing cover, using a brass washer at the speedometer gear location.

10. Reassemble and Install Synchronizer Assembly.

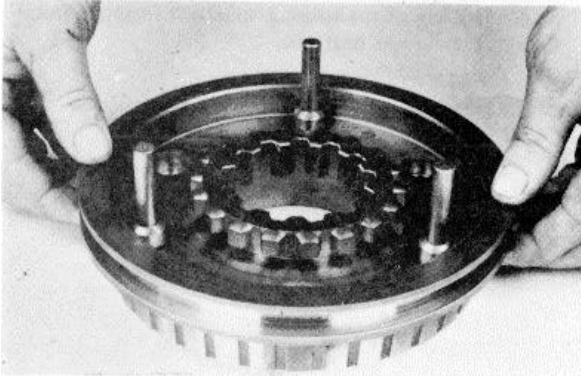

Install the sliding clutch on the pins of the low speed synchronizer, recessed side up.

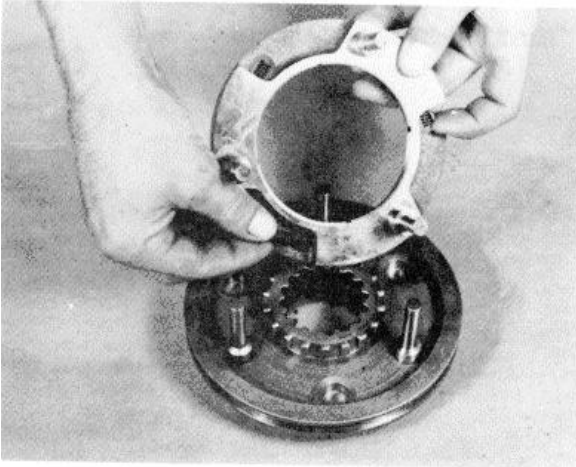

Install the three springs in the direct synchronizer.

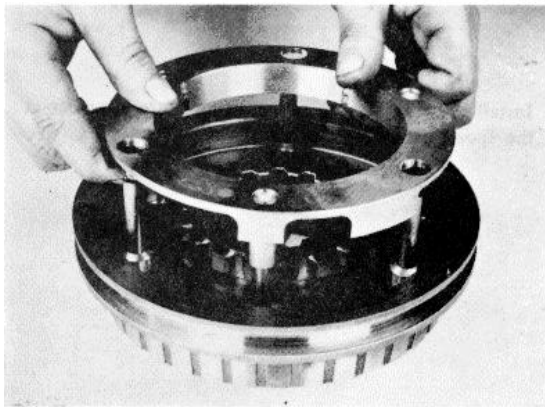

Place the direct synchronizer over the low speed blocker pins, seating the springs against the pins.

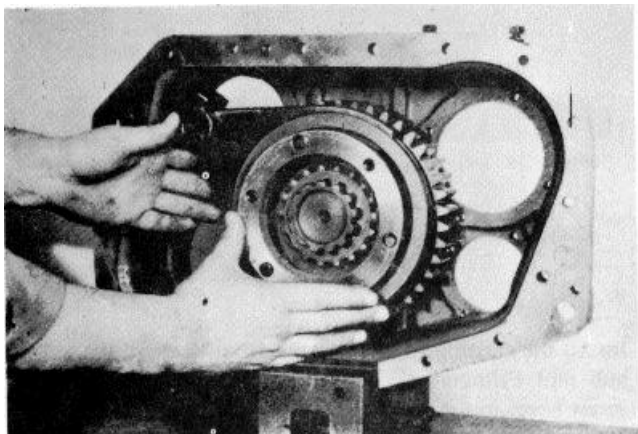

Compress the springs to fully seat the direct synchronizer on the pins of the low speed synchronizer.

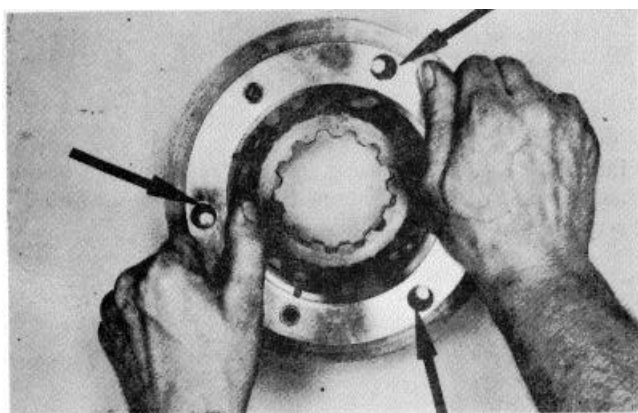

Place the direct-low shift fork into the yoke slot of the sliding clutch, short hub to the rear, and install the synchronizer assembly on the splines of the output shaft.

11. Reassemble and Install Auxiliary Shift Cylinder.

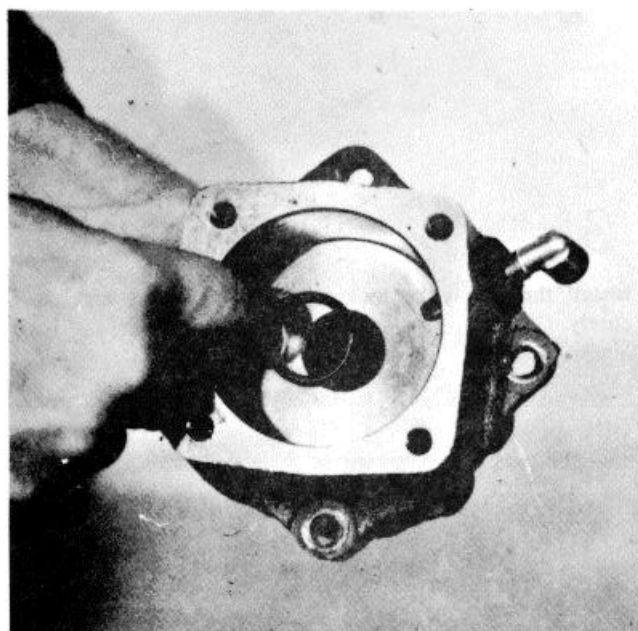

Install the O-ring in the bore of the shift cylinder.

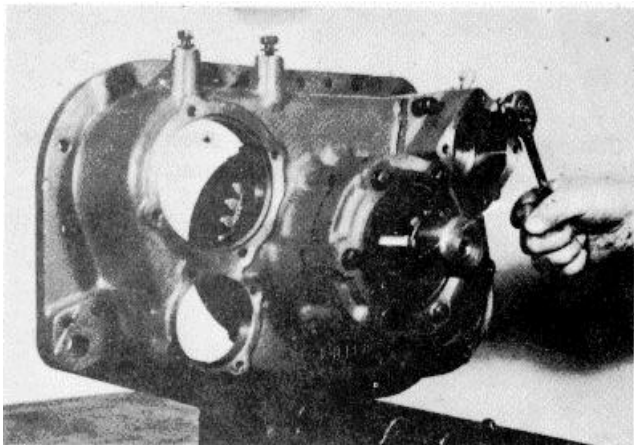

Install the cylinder housing into the rear housing bore and secure with four capscrews, noting that the air fitting is on the top right of the housing.

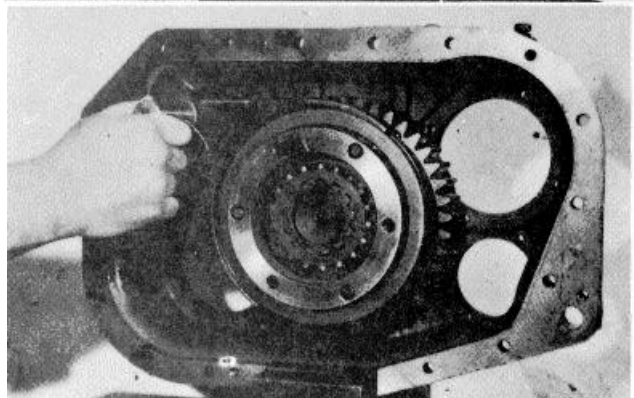

Install the shifting shaft from the front through the yoke hub and cylinder, aligning the notches with the lock screw bores in the yoke hub.

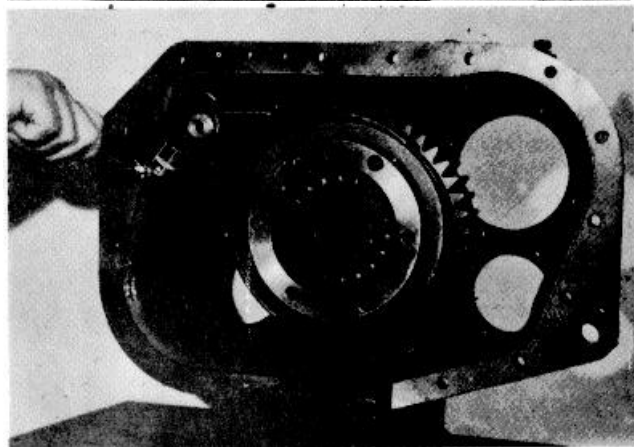

Install the two yoke lock screws, tighten and wire securely.

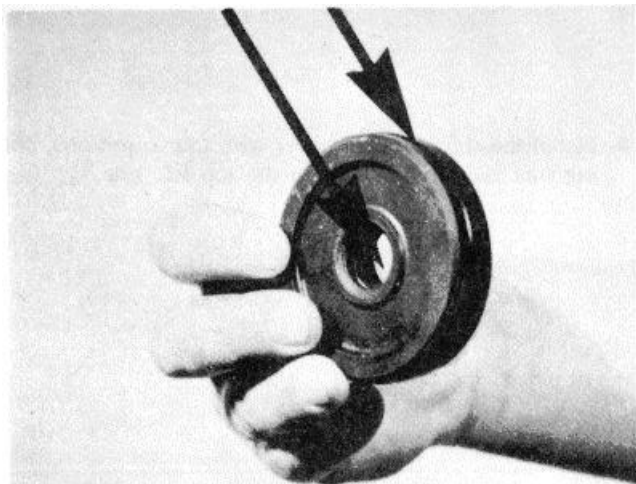

Install O-rings in the OD and ID of the piston.

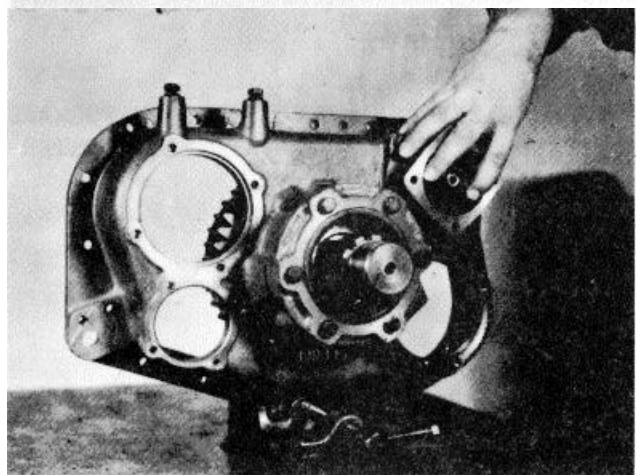

Install the piston on the shifting shaft, flat side out.

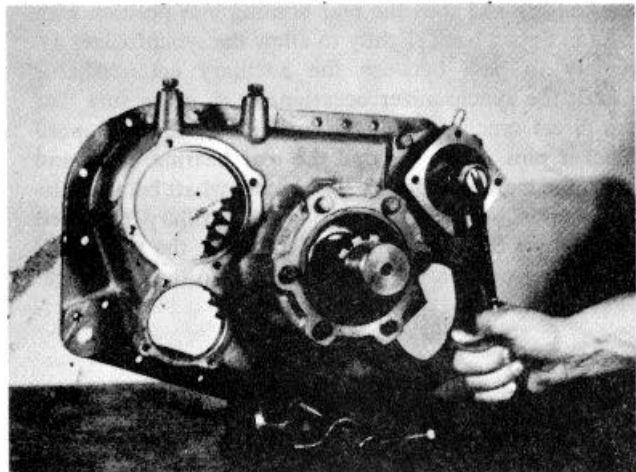

Install the locknut on the shifting shaft.

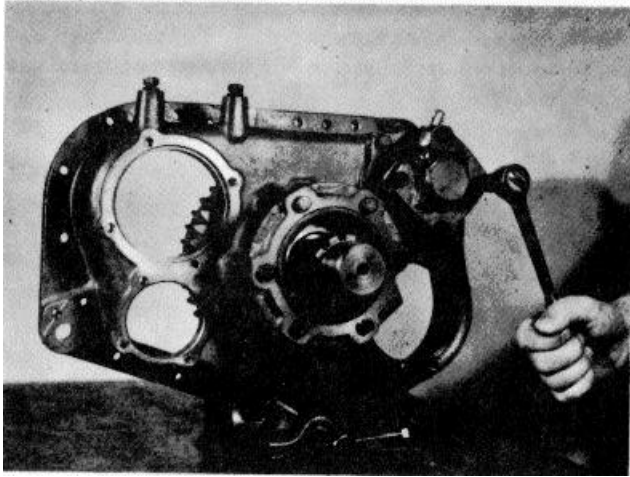

8. Install the shift cylinder cover with four capscrews, noting that the air fitting is on the top left side.

12. Install Auxiliary Rear Housing.

NOTE

MAKE SURE THAT PRIOR TO INSTALLATION THE SYNCHRONIZER ASSEMBLY IS AS FAR FORWARD AS POSSIBLE ON THE TAILSHAFT AND THAT THE MARKED TEETH ON THE AUXILIARY COUNTER-SHAFTS ARE FACING EACH OTHER.

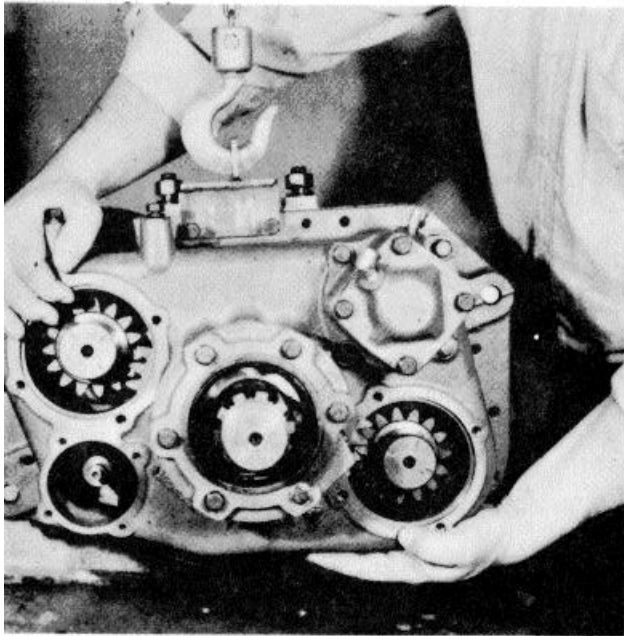

Using a hoist, move the rear housing up to the intermediate housing and start the rear housing into position with the top tipped back slightly to allow the synchronizer assembly to pass between the auxiliary countershafts. Check the synchronizer occasionally to make sure that the direct synchronizer is not slicing off the low speed blocker pins. Look through the rear bearing bores and mesh the marked tooth on each countershaft between the two marked teeth on each side of the auxiliary low speed gear. Move the rear housing evenly onto the two dowel pins, using caution to prevent damage to the oil trough.

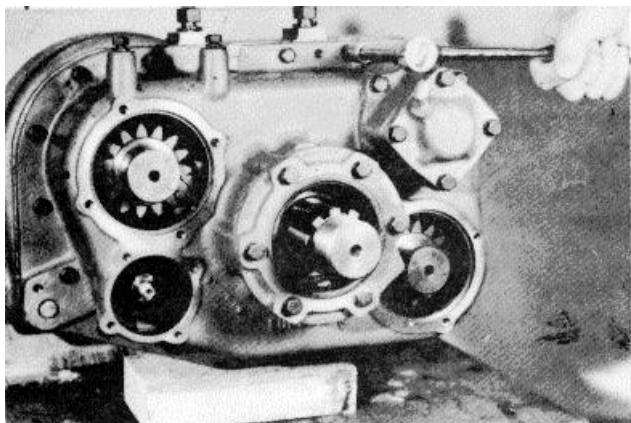

Secure the rear housing with the retaining capscrews.

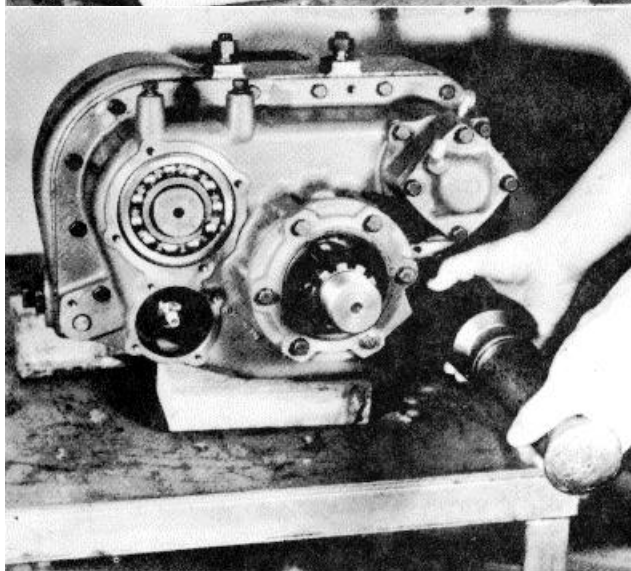

Use a soft bar and mallet against the rear of both auxiliary countershafts to seat the front bearings and use a bearing driver to install the rear bearings on the shafts and in the bores.

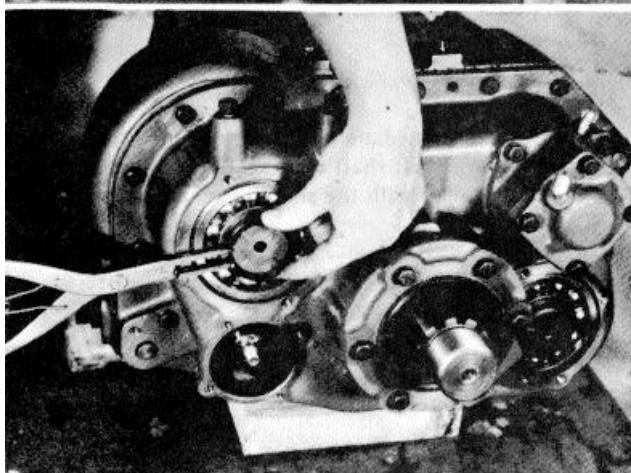

Install the rear bearing retaining snap rings in the countershaft grooves.

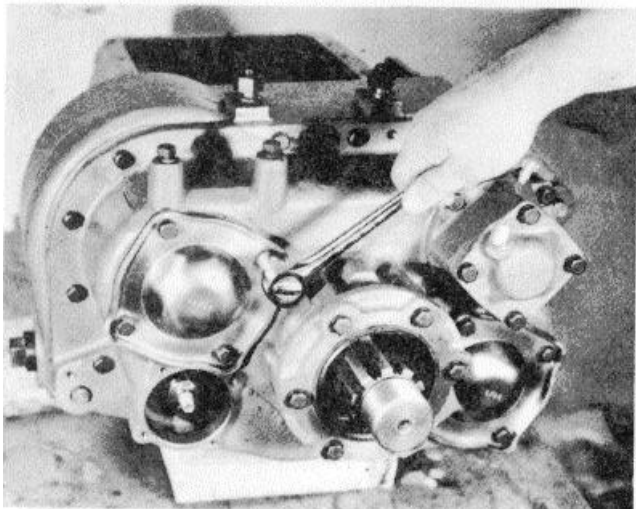

Install the rear bearing covers.

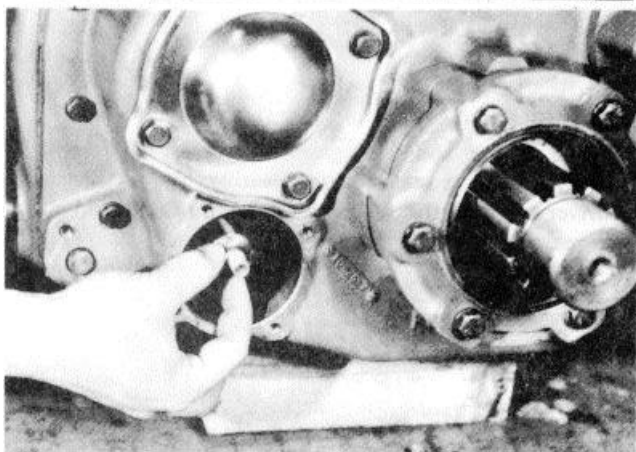

Install the O-ring on the intermediate shift shaft.

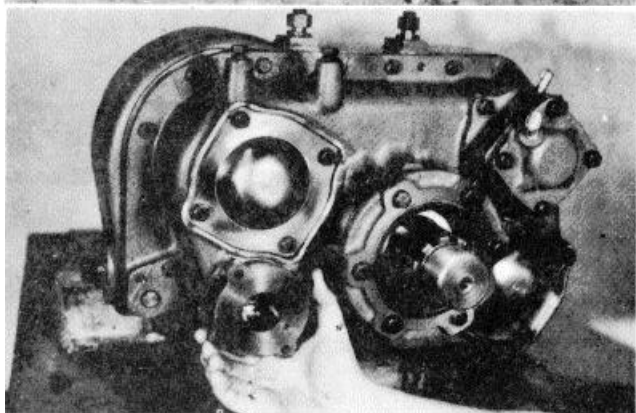

Install the intermediate shift cylinder in the rear housing, fitting the shift shaft through the cylinder bore. Cylinder is installed with the small air channel in the housing to the right.

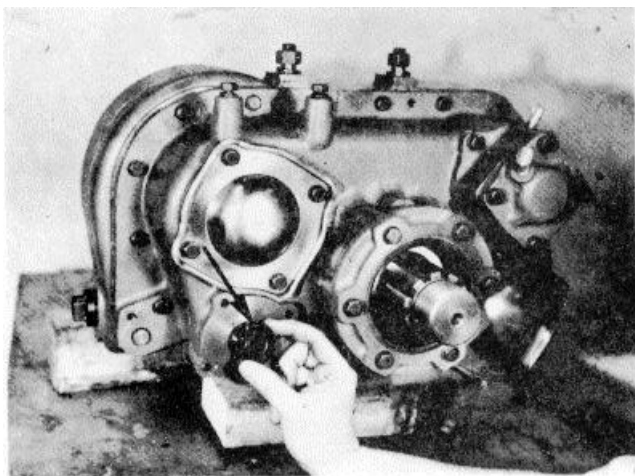

Install the O-ring on the outer diameter of the piston and install the piston on the shaft in the cylinder.

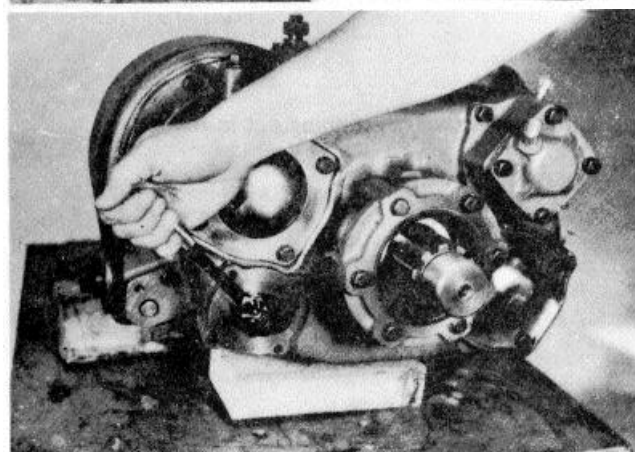

Install the elastic stop nut on the shift shaft.

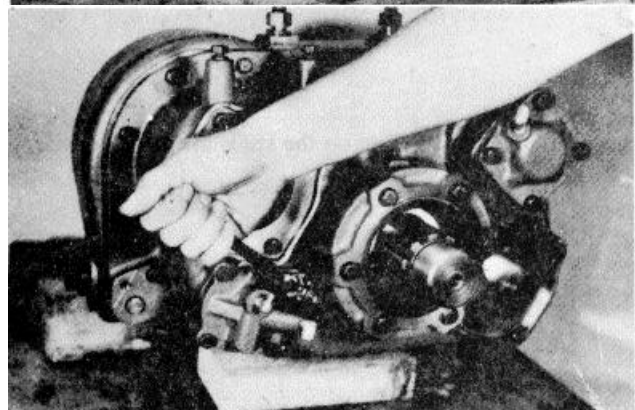

Install the shift cylinder cover, aligning the small air channel on the cover with the channel in the housing. The insert valve opening on the cover will be facing down.

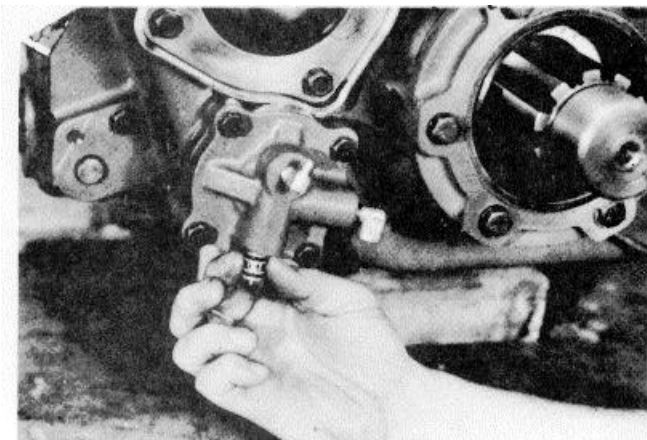

If previously removed, install the insert valve in the cover with the flat end facing up.

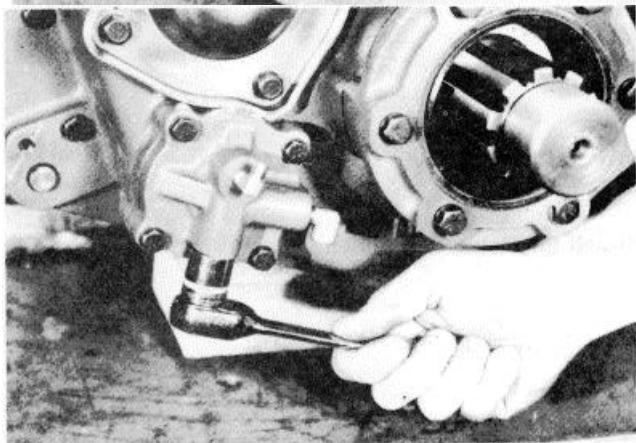

Install the insert valve retaining nut in the cover.

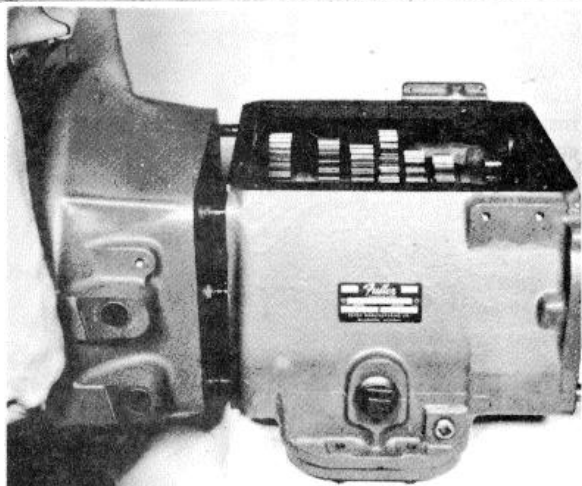

Install the clutch housing on the studs in the front case.

14. Install Companion Flange.

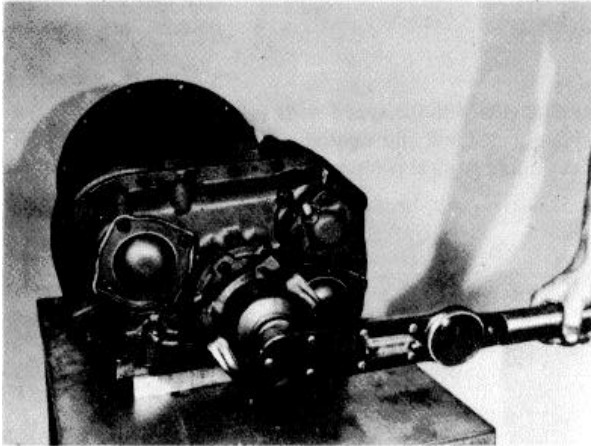

Install the speedometer drive gear or replacement spacer on the hub of the yoke or flange, lock the transmission in two speeds and install the yoke or flange on the splines of the tailshaft. Install the tailshaft nut and torque to 450-500 ft./lbs.

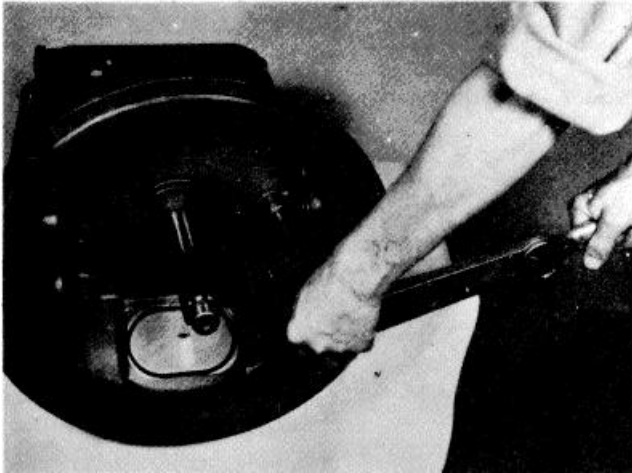

Install the 4th-5th speed shift bar and yoke. Install the yoke lock screw and tighten and wire securely. Keep the bar in the neutral position.

15. Reassemble and Install Shaft Bar Housing.

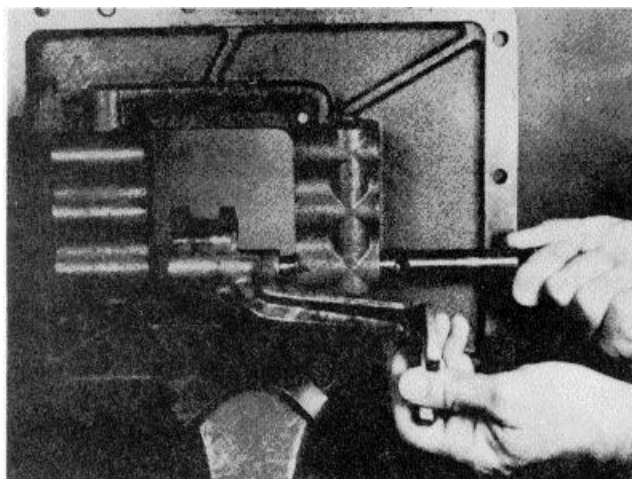

Install the 4th-5th speed shift bar and yoke. Install the yoke lockscrew and tighten and wire securely. Keep the bar in the neutral position.

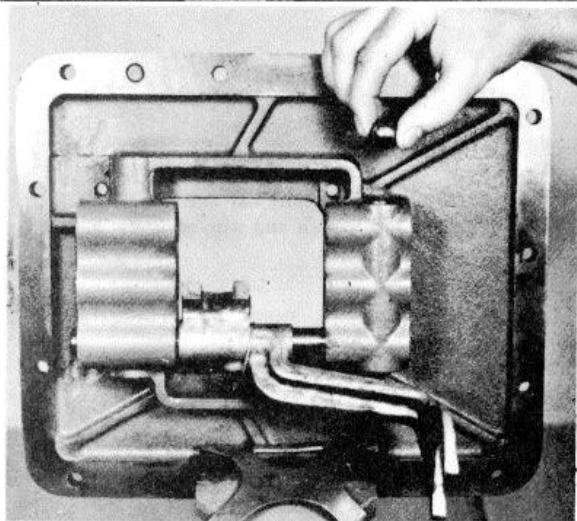

Install an interlock ball in the front web.

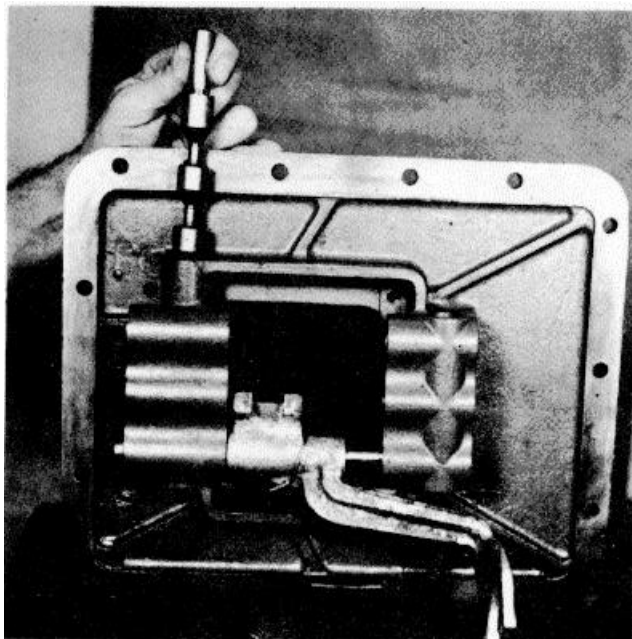

Install the actuating plunger in the rear web.

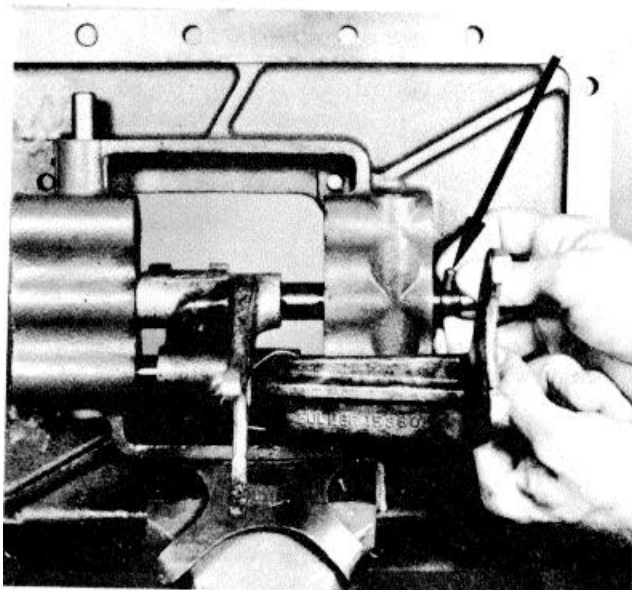

Install the 2nd-3rd speed shift bar and yoke, inserting the interlock pin in the bore of the neutral notch. Install the yoke lockscrew and tighten and wire securely.

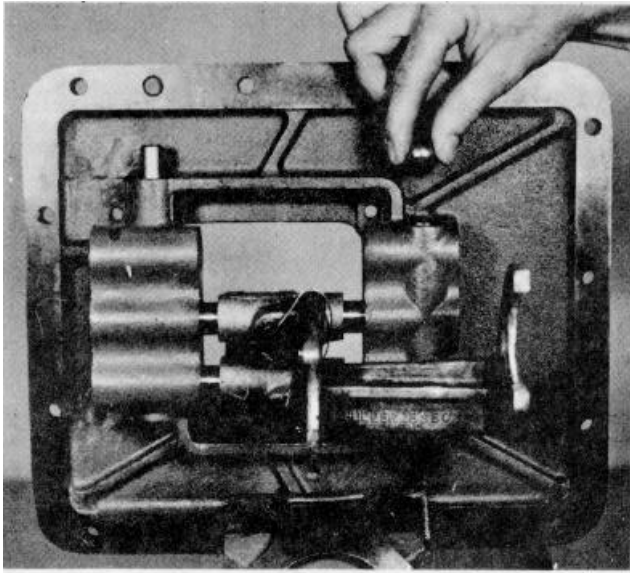

Install an interlock ball in the front web.

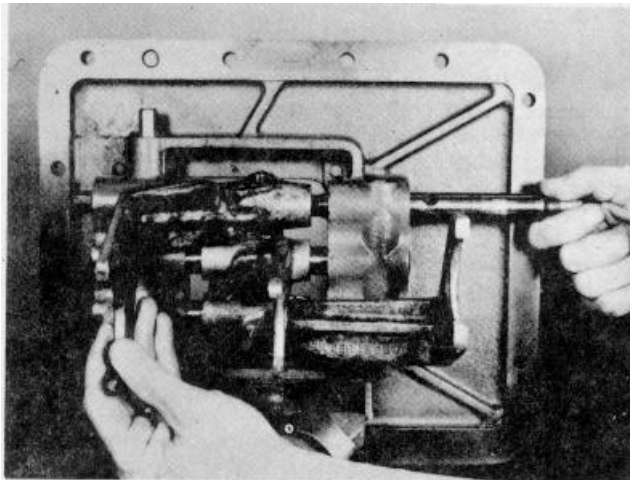

Install the 1st-reverse shift bar and yoke. Install the yoke' lock screw and tighten and wire securely.

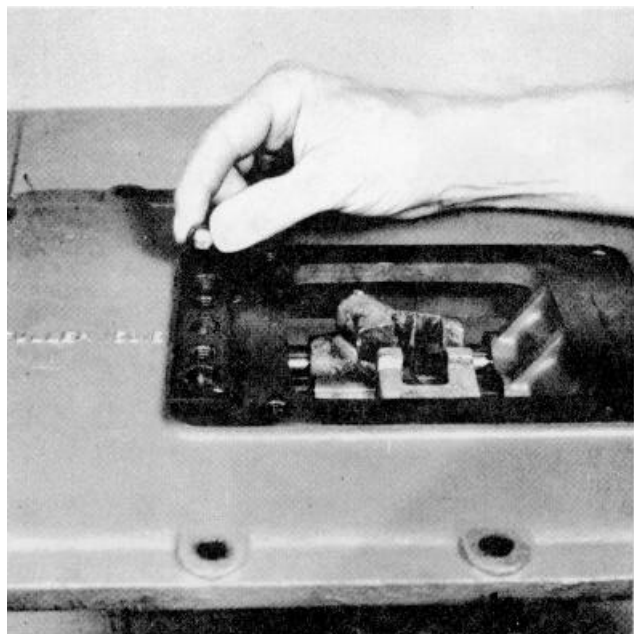

Remove the assembly from the vise and install the three tension balls, one in each bore in the top of the housing.

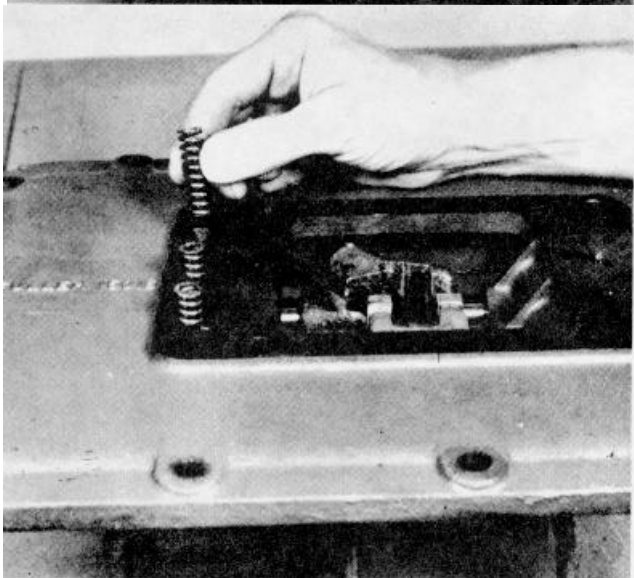

Install the tension springs on top of the balls in the bores.

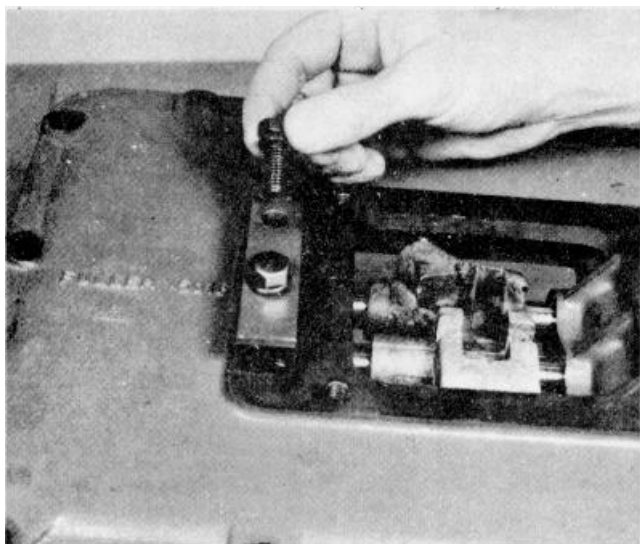

Install the tension spring cover and retain with the two capscrews.

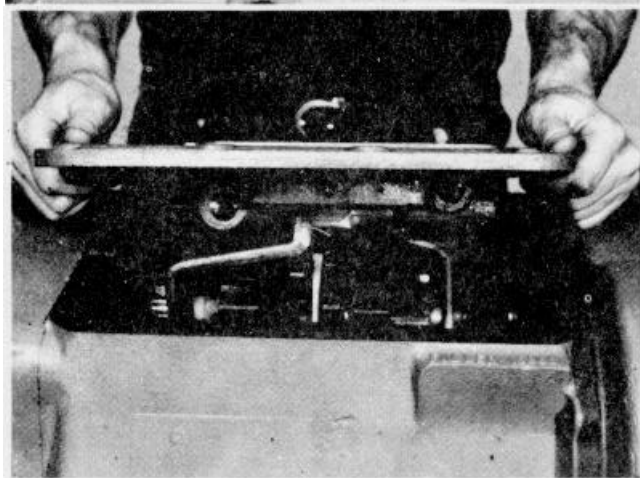

Check to make sure that the shift yokes and sliding clutches are in the neutral position and install the shift bar housing on the transmission, tension spring cover to the front and the yoke forks in the sliding clutches. Secure with the 13 capscrews.

16. Reassemble and Install Gear Shift Lever Housing.
Refer to Slave Unit and Gear Shift Linkage Installation.

17. Install Air System.



Install the actuating pin and spring in the bore in the case.



Install the hat-type alignment sleeve in the air valve.



Install the air valve on the transmission, using air to move the piston all the way forward or to the rear before installing the air valve.

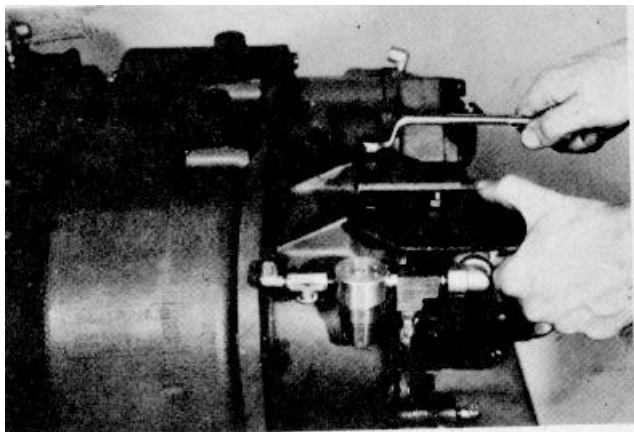

Attach the air filter/regulator assembly to the rear housing with the two retaining capscrews.

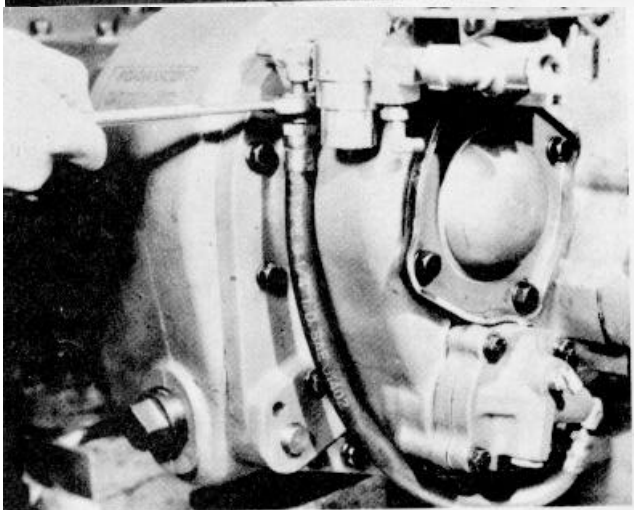

Connect the 1/4" air line between the intermediate shift cylinder and the air filter/regulator assembly.

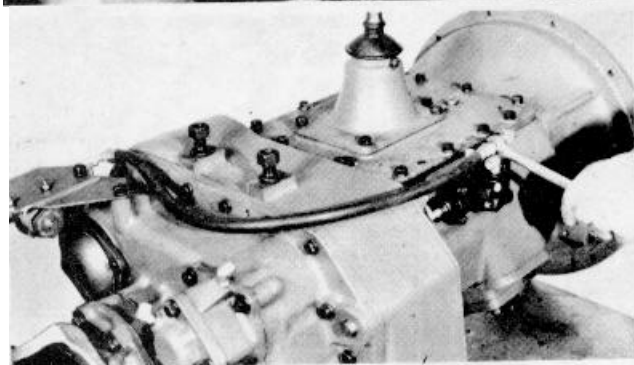

Connect the 1/4" ID air line between the air filter/regulator assembly and the rear port of the tee fitting on top of the air valve.

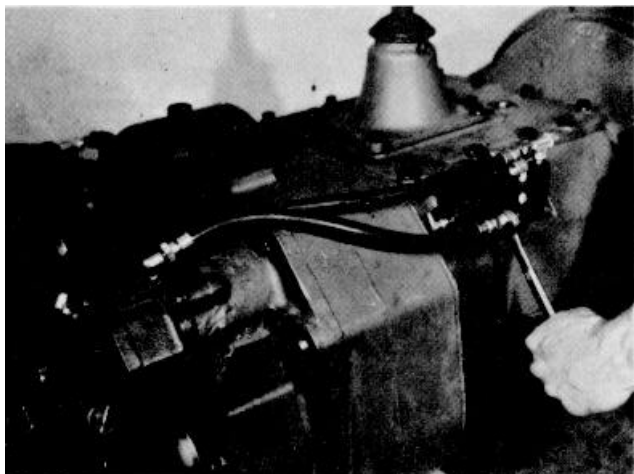

Connect the ¼" ID air line between the air valve and the low range port of the auxiliary shift cylinder.

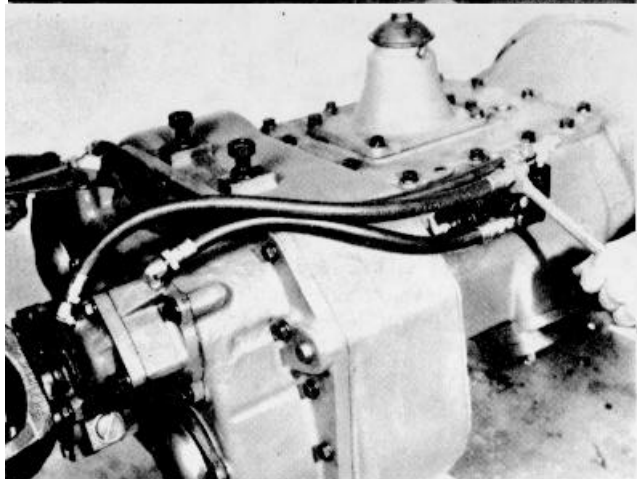

Connect the ¼" ID air line between the air valve and the direct range port of the auxiliary shift cylinder.

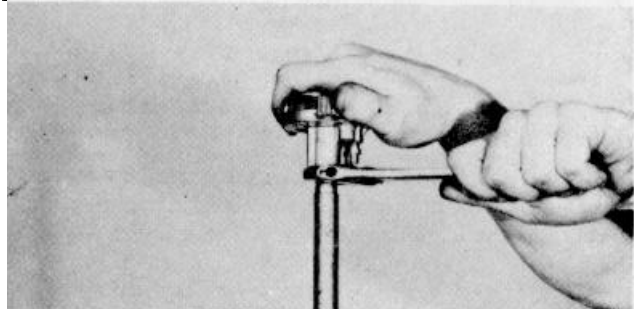

Install the 1/8" OD air lines, sheathing and O-rings on the shifting lever. Install the jam nut and control valve and back the jam nut up against the control valve to secure it in the desired position.

NOTE

TO AVOID CONFUSION, ONLY THE AIR LINE BEING INSTALLED IN EACH OF THE FOLLOWING THREE STEPS IS SHOWN ATTACHED TO THE CONTROL VALVE.

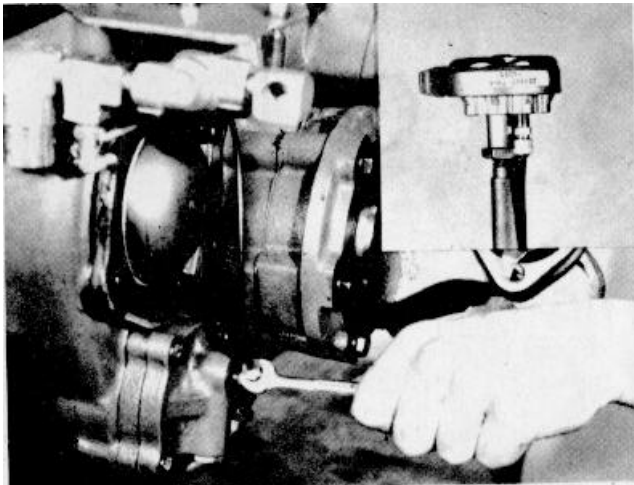

Connect the 1/8" OD long black air line between the intermediate shift cylinder and the port in the control valve identified with an "F". (See insert.)

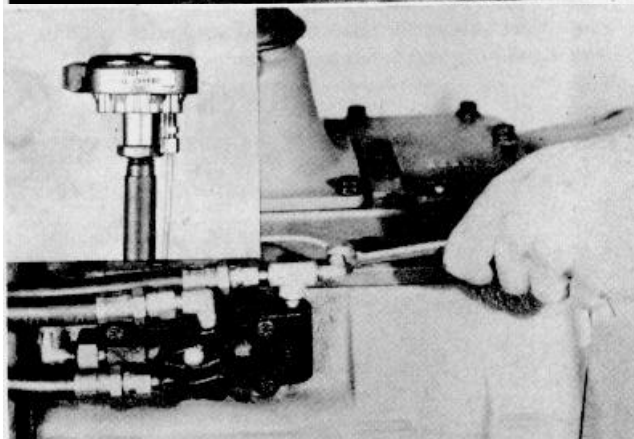

Connect the 1/8" OD white air line between the forward fitting on the slave air valve and the port in the control valve identified with an "S". (See insert.)

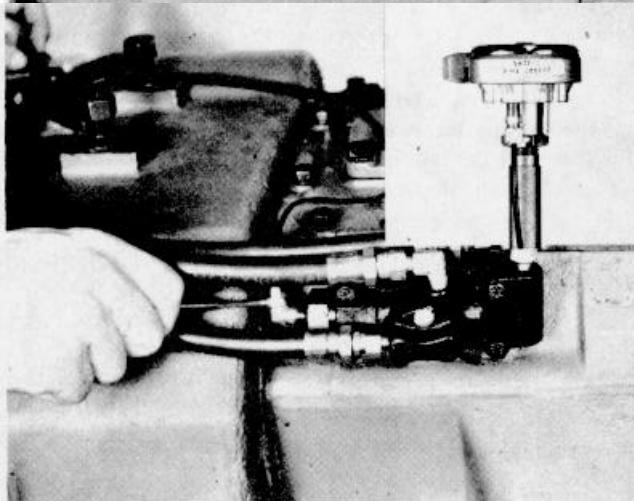

Connect the 1/8" OD short black air line between the rear fitting on the slave air valve and the port in the control valve identified with an "R". (See insert.)

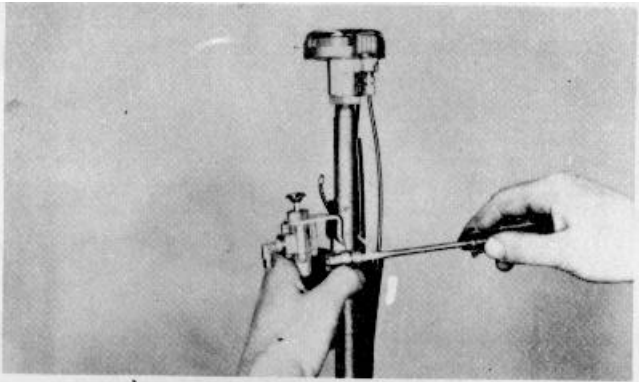

If so equipped, attach the countershaft brake control valve and clamp to the shift lever and secure the valve by tightening the screw on the clamp.

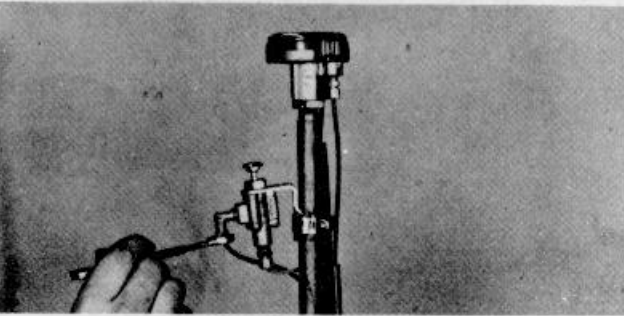

Attach the black 1/8" OD brake control air line to the elbow fitting on the front of the valve and attach the white air line to the fitting on the bottom of the valve.

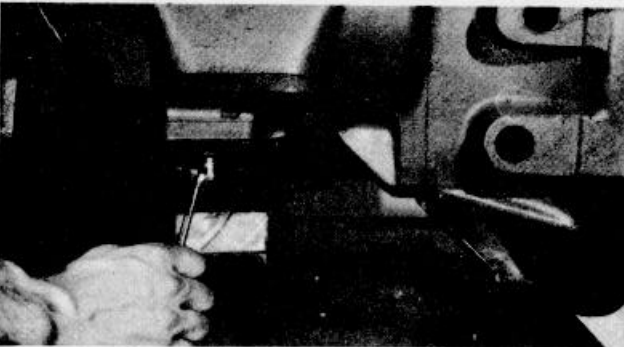

Attach the black 1/8" OD air line to the TCB-6 countershaft brake located on the right PTO opening.

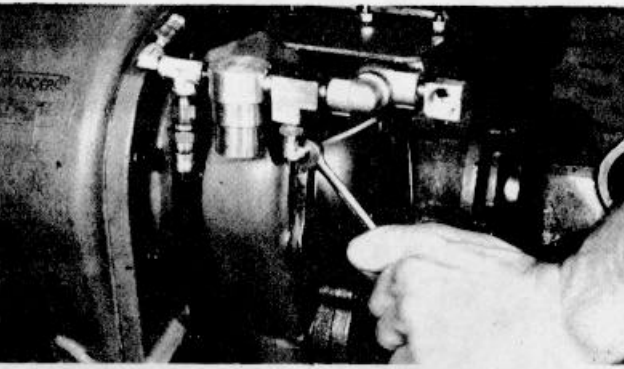

Attach the white 1/8" OD air line to the tee block between the air filter and regulator.

Clutch.**REMOVAL (Illus. 4-43).**

1. Remove transmission from engine.
2. Remove clutch from engine clutch removal is obvious. Therefore no removal procedures are given.

INSTALLATION (Illus. 4-43 and 4-44).

1. Check flywheel from correct depth. Flywheel depth should be 1.065 in. + .005 in.
2. Replace release bearing and carrier, and flywheel pilot bearing. Pilot bearing should be a hand press fit in the flywheel recess and on the transmission drive gear. The release yoke or fork should contact the release bearing carrier pads evenly to prevent a bind on the front bearing cap extension.
3. Friction face of the flywheel must be free from heat cracks score marks and taper.
4. Before installing the clutch, the intermediate plate should be set into the driving slots of the flywheel and clearances checked. A minimum of .006 in. is recommended to allow for free movement of the intermediate plate.
5. The two disc assemblies for a two plate clutch may or may not be identical or interchangeable. In most cases they will not be interchangeable and will be marked either flywheel side or pressure plate side. They must be positioned with the side of the disc as marked, next or adjacent to the respective part. In no instance shall the hubs be allowed to approach pilot bearing or come together within 5/32 in.
6. When installing the clutch, it is essential that a splined shaft or aligning shaft be used with a key to properly align the two disc assemblies.
7. To obtain complete disengagement, the release levers must be actuated a specified distance from the engaged position. Assuming the release bearing clearance (distance between the clutch release levers and release bearing) is 1/8 in. when the clutch is in the engaged position, the release bearing must move forward 1/8 in. to take up this clearance before it contacts the release levers and then move the normal amount of travel required to disengage the clutch as shown below.

NOTE

IF RELEASE LEVERS ARE NOT IN PLANE, IT IS AN INDICATION THAT COVER IS NOT PROPERLY SEATED IN FLYWHEEL.

8. Check the distance from the top of the clutch flywheel ring (cover) to ends of release levers. Distance should be 1 3/32 in. $\pm 1/32$. Satisfactory operation of the clutch depends upon the accuracy of the lever setting as this controls parallel movement of the pressure plate.
9. Check release lever travel. Travel should be:

Release Bearing Clearance 1/8 in.
 Normal Release Bearing Travel 1/2 in.
 Total Bearing Travel Required 5/8 in.

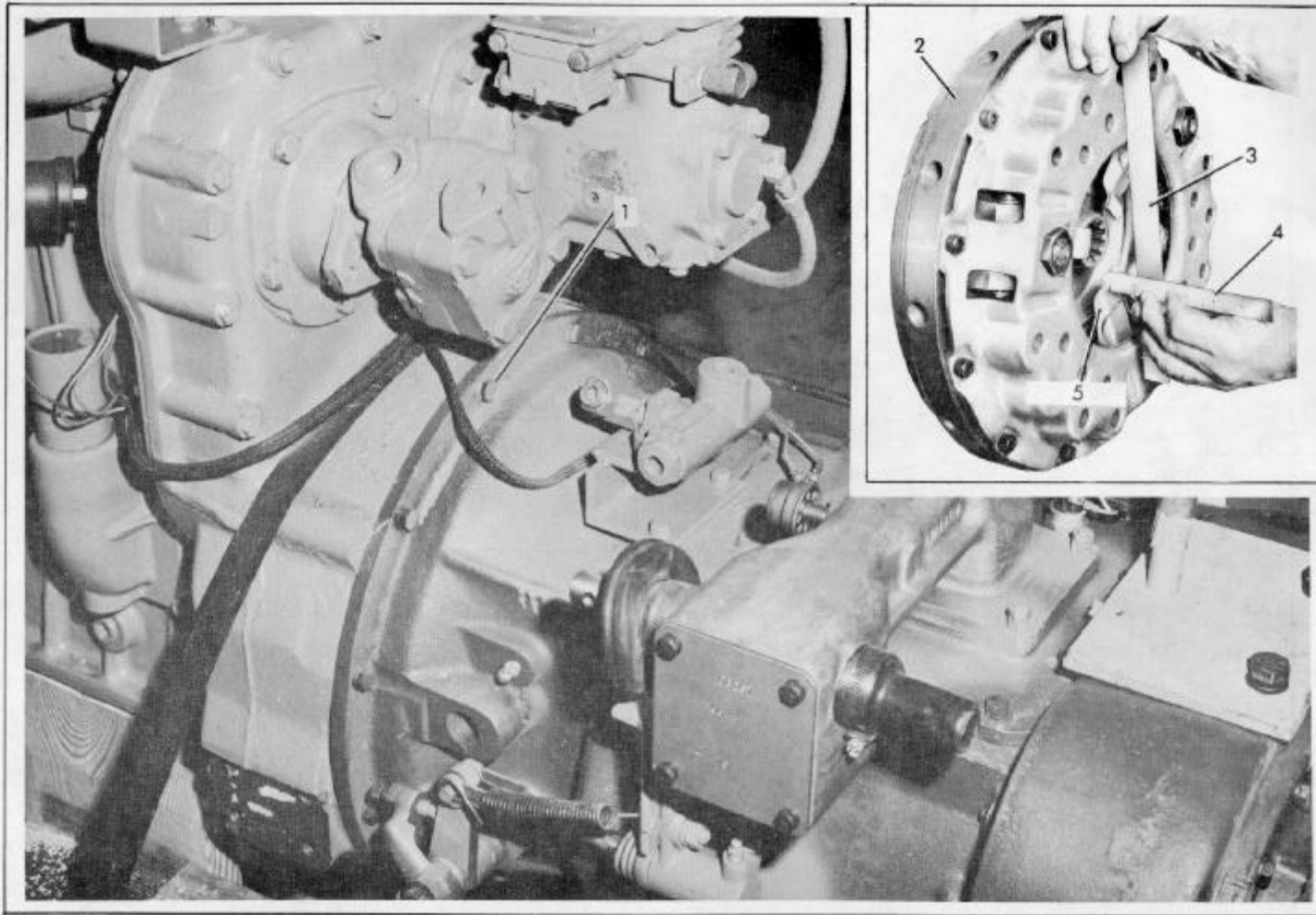

- 1. Bolts
- 2. Engine Flywheel
- 3. Straight Edge
- 4. Scale
- 5. Release Lever

Illustration 4-43. Clutch Removal.

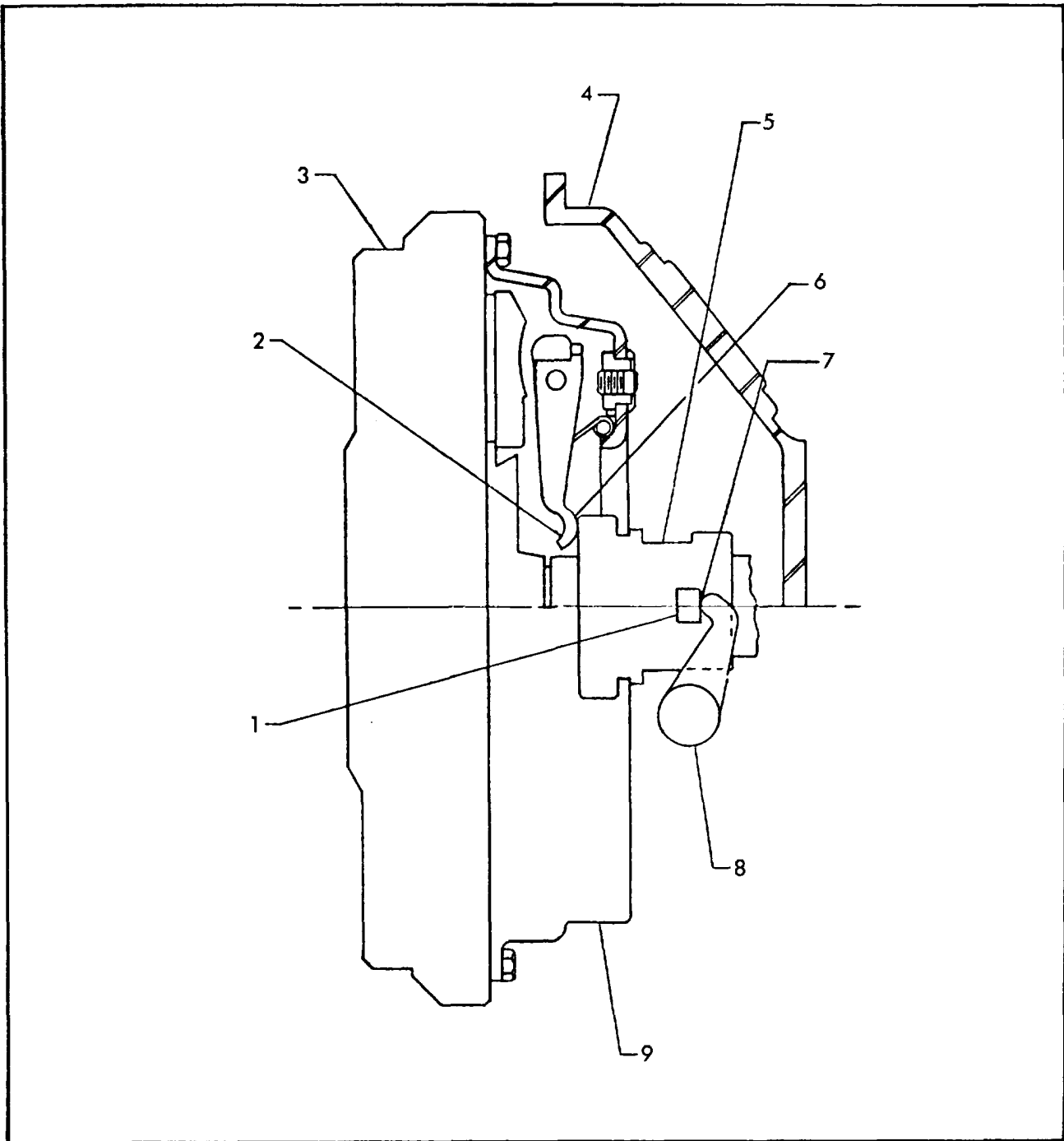

- 1. Release Bearing Wear Pad
- 2. Release Lever
- 3. Flywheel
- 4. Bell Housing
- 5. Release Bearing
- 6. Point B
- 7. Point C
- 8. Release Yoke
- 9. Cover Assembly

Illustration 4-44. Clutch Adjustment. (Sheet 1 of 4)

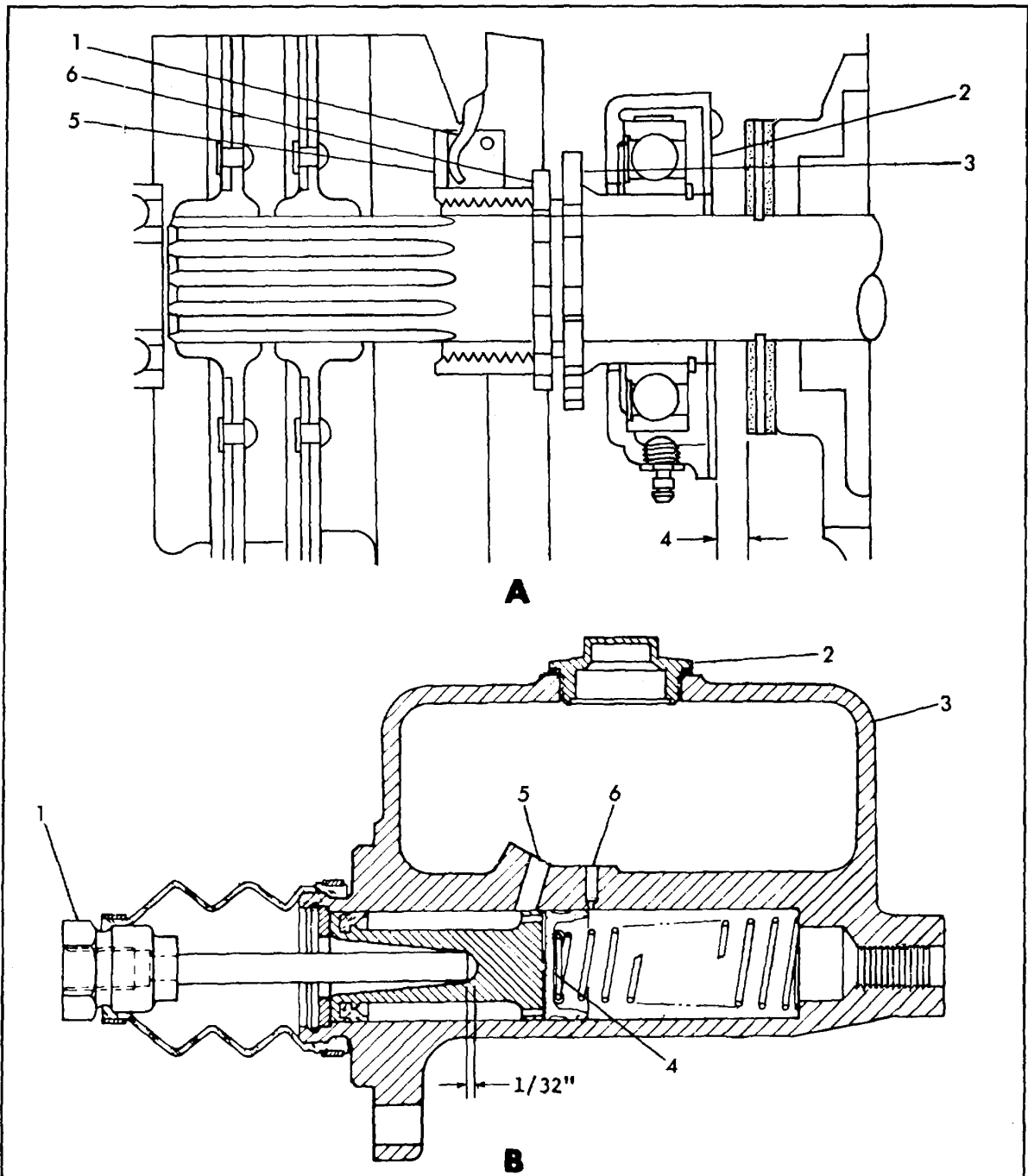

- | | |
|---|--|
| <p>A. Release Bearing Assembly</p> <ul style="list-style-type: none"> 1. Release Lever 2. Release Bearing Housing 3. Adjustment Nut 4. Clearance for Release Travel 5. Release Lever Spider 6. Sleeve Locknut 6. By-Pass Port | <p>B. Master cylinder</p> <ul style="list-style-type: none"> 1. Push Rod 2. Cover 3. Housing 4. Primary Cup 5. Intake Port |
|---|--|

Illustration 4-44. Clutch Adjustment. (Sheet 2 of 4)

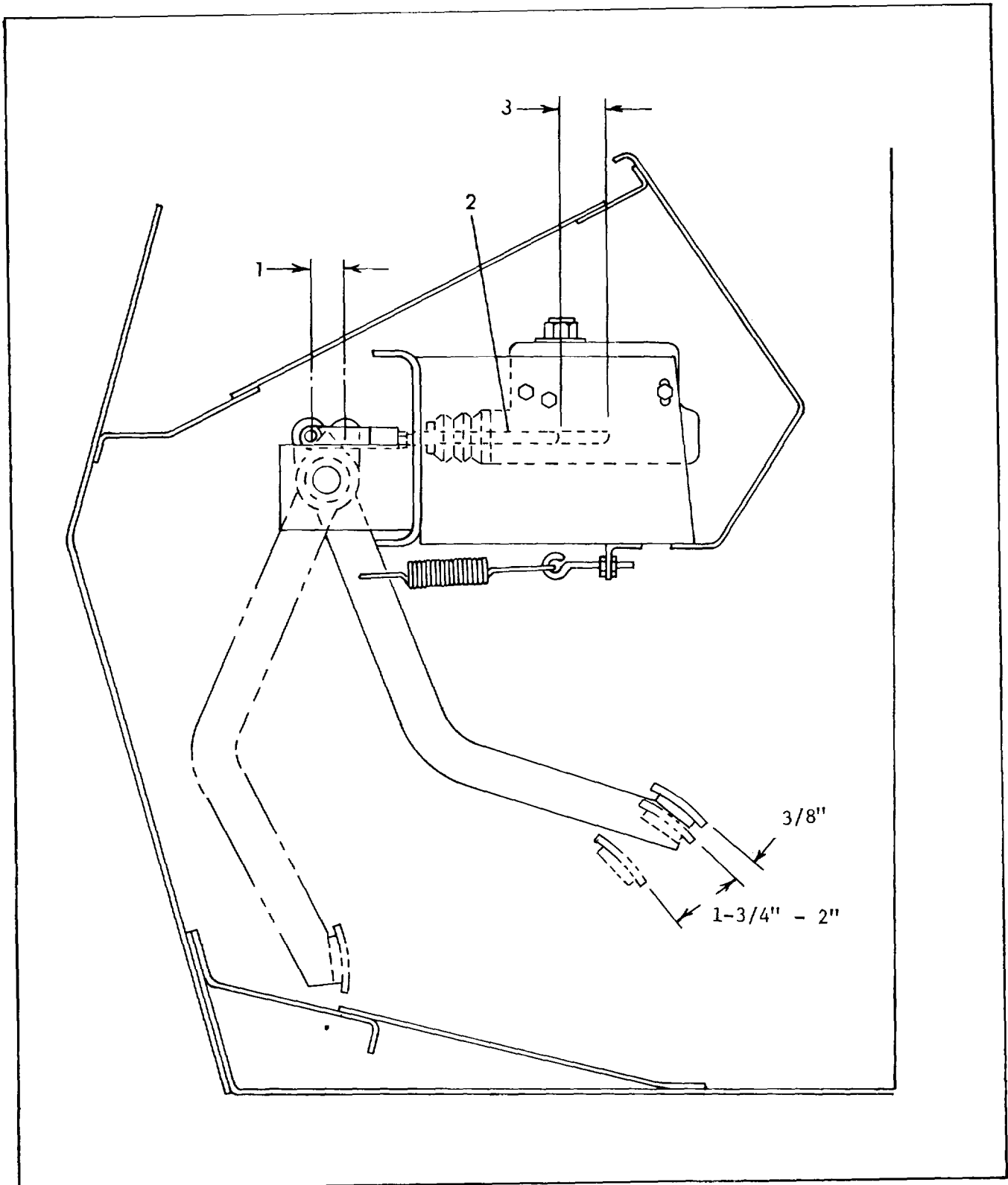

1. 7/8" Stroke
2. Check Push rod for Freedom of Movement
3. 1 1/4" max. Obtainable Master Cylinder Stroke

Illustration 4-44. Clutch Adjustment. (Sheet 3 of 4)

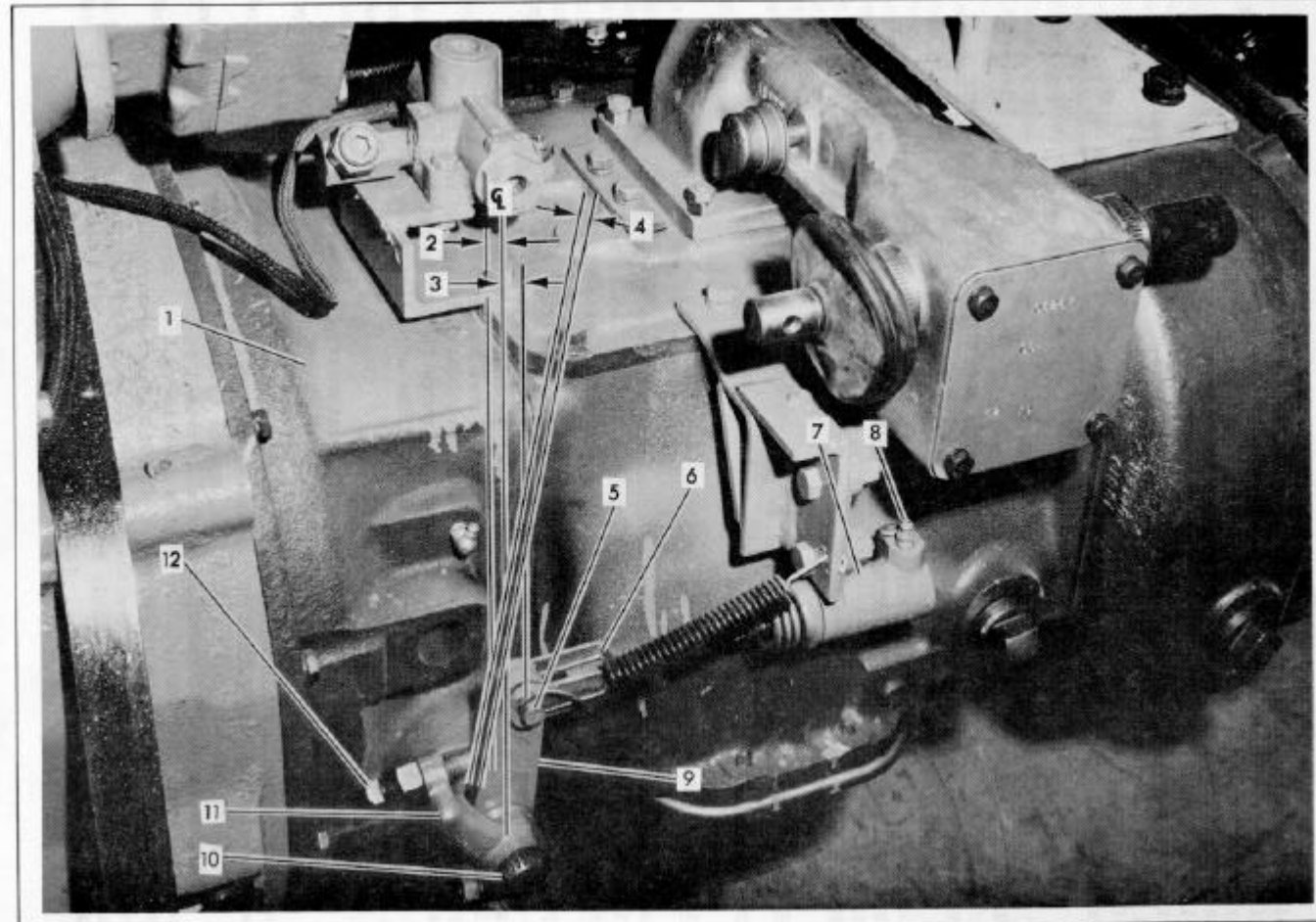

- | | | | | | |
|------------------|-------------------------|-------------|-------------------|------------------|----------------------------------|
| 1. Clutch | 3. 11/16" Travel | 5. Yoke Pin | 7. Slave Cylinder | 9. Crank | 11. Clutch Pedal Adjusting Lever |
| 2. 11/16" Travel | 4. 6/32" Wear Clearance | 6. Yoke | 8. Bleed Screw | 10. Clutch Shaft | 12. Adjusting Screw |

Illustration 4-44. Clutch Adjustment. (Sheet 4 of 4)

10. Try the cover assembly on the flywheel without the disc assembly to check fit where cover is piloted at O.D.
11. Install driven disc, making sure that it is properly positioned and insert an aligning shaft. Normally the long end of the driven disc hub extends toward the transmission, but in a few instances the long end may face toward the engine. Make sure that the driven disc hub does not come within 5/32 in. of the pilot bearing.
12. Bolt the cover assembly to the flywheel, tightening each cap screw gradually until the cover is drawn up tight. Extreme care must be exercised to make sure flywheel ring or cover is seated in pilot rim on recessed type flywheels.

NOTE

SOME COVER ASSEMBLIES ARE BOLTED TO THE FLYWHEEL BY CAP SCREWS WITH A GROUND SHANK WHICH FITS THE REAMED HOLES IN THE COVER. THE MACHINED SHANK EXTENDS THROUGH THE COVER INTO A RECESSED OR COUNTERBORED HOLE IN THE FLYWHEEL. IF A FLYWHEEL HAS BEEN REGROUND THERE IS A CHANCE THAT THE COUNTER BORES COULD BE TOO SHALLOW AND MAY REQUIRE DEEPENING. IF THE FLYWHEEL HAS BEEN REMACHINED SEVERAL TIMES TO REMOVE HEAT CRACKS OR SCORES, THE COUNTERBORED HOLES MAY NOT BE DEEP ENOUGH TO ALLOW COMPLETE TIGHTENING OF THE CAP SCREWS. THIS WILL NECESSITATE REPLACING THE FLYWHEEL.

Clutch Actuating System.

ADJUSTMENT. (Illus. 4-44).

Clutch Linkage.

1. The master cylinder and slave cylinder hydraulic system must be purged of air. This is done by opening the bleed screw on the slave cylinder and pumping the master cylinder with the clutch pedal until the air bubbles at the bleed screw stop. Tighten the bleed screw to prevent loss of fluid after the system has been purged. This operation is similar to bleeding a hydraulic brake system.
2. Check clutch pedal Free Travel by hand rather than by foot to make sure proper linkage clearances have been made. Free Travel is the first easy movement of the clutch pedal. There are two distinct Free Travel ranges. The first range is approximately 3/8" and it offers no pedal resistance. It is the result of the master cylinder primary cup. The second range is approximately 1 3/4" to 2" and it results from the clearance between the adjusting screw and the crank on the clutch housing.

It is important when making clutch linkage adjustments, that the master cylinder piston does not "bottom out" against the push rod. If properly adjusted, there will be approximately 1/32" free-play between the master cylinder push rod and piston when the clutch pedal is against its stop. This clearance will ensure the complete return of the master cylinder push rod and will allow the piston primary cup to clear the master cylinder bypass port. The 1/32" clearance is to be determined by the looseness in the push rod when the clutch is engaged. With the piston in this position, fluid movement through the bypass port compensates the closed hydraulic system for fluid expansion or contraction due to temperature change and for seepage. Failure to properly release expanded fluid could result in a slipping clutch and premature clutch failure.

3. A further check can be made to determine whether the piston primary cup has cleared the bypass port. After cycling the clutch several times, release the clutch pedal and remove the cover from the master cylinder fluid reservoir. Apply the clutch again and upon release the fluid should spurt through the bypass port and be visible within the fluid reservoir.
4. Retract the slave cylinder until the piston bottoms and the shortest cylinder length is obtained. Set the crank so that it is approximately 1/2" behind the vertical centerline. Adjust the yoke so that the yoke pin can be inserted into the crank without changing the slave cylinder piston position. Turn the yoke locking nut into the yoke so that the yoke is locked to the piston rod and the length is fixed.
5. Position the clutch pedal adjusting lever on clutch shaft so that the adjusting screw can be located with approximately equal adjustment in either direction. Set the adjusting screw to obtain 1/8" clearance with the crank as shown.

NOTE

THE RELEASE YOKE MUST BE IN CONTACT WITH THE BEARING CARRIER WEAR PAD AND THE RELEASE BEARING MUST BE IN CONTACT WITH THE RELEASE LEVER WHEN MAKING THE 1/8" CLEARANCE ADJUSTMENT.

INSPECTION - CLUTCH ADJUSTMENT. (Illus. 4-44).

1. Remove the inspection plate from the bottom of the clutch housing. With the proper clearance set, depress and release the clutch several times and check the travel of the release bearing. Then position the release bearing to obtain exactly 1/8 in. clearance. When the clutch linkage is properly adjusted the clearance will be zero and the slave cylinder will be adjusted per Step 4. If readjustment is required, refer to Steps 4 and 5. Install inspection plate on bottom of clutch housing and road test carrier for proper clutch operation.

IN-SERVICE. (Illus. 4-44).

1. The 1/8" clearance between the adjusting screw and crank and the clutch pedal free travel will diminish as the clutch linings wear. If the clutch pedal free travel reduces to 1", the 1/8" clearance must be reestablished to avoid clutch slippage and short clutch life. Adjustment of the clutch pedal linkage should be done as indicated in Steps 4 and 5.

COMMON SERVICE PROBLEMS

PROBLEM	REMEDY
CHATTER	
<ol style="list-style-type: none"> 1. Loose, broken or worn engine mounts. 2. Pedal linkage worn 3. Loose or cracked clutch housing 4. Spring shackles and mountings loose, worn or broken. 5. Misalignment 6. Oil or grease on facings 7. Warped or bent driven disc assembly. 8. Improper disc facing thickness 9. Worn pilot bearing 10. Wrong spring pressure in cover assembly. 11. Improper "A" dimension (Type ML only). 12. Unequal quantity of shims under straps of ML clutch. 13. Release levers not parallel. 	<ol style="list-style-type: none"> 1. Tighten or replace. 2. Replace linkage. 3. Tighten or replace. 4. Tighten or replace. 5. Realign. 6. Install new facings or disc assembly. 7. Install driven disc assembly. 8. Install proper disc assembly. 9. Replace 10. Replace with proper cover assembly. 11. Adjust for "A" dimension according to ML charts. 12. Use same quantity of shims under each strap. 13. Recheck installation.
AGGRESSIVE	
<ol style="list-style-type: none"> 1. Release sleeve dry (Type ML only) 2. Worn or loose pedal linkage 3. Excessive backlash in power train 4. Warped driven disc 5. Worn hub splines 6. Worn splines on splined shaft 7. Improper facing material 	<ol style="list-style-type: none"> 1. Lubricate release sleeve. 2. Replace or tighten. 3. Adjust or replace worn parts. 4. Install new disc assembly. 5. Install new disc assembly. 6. Replace shaft. 7. Install proper driven disc assembly.
INSUFFICIENT RELEASE.	
<ol style="list-style-type: none"> 1. Broken or loose motor mounts 2. Worn or loose pedal linkage 3. Excessive idling speed 4. Loose or worn facings 5. Improper facing thickness. 6. Warped or bent driven disc assembly. 7. Lever settings wrong. 8. Worn splines. 9. Worn or rusty splines on splined shaft. 10. Worn pilot bearing. 	<ol style="list-style-type: none"> 1. Replace or tighten. 2. Replace or tighten. 3. Adjust to factory specs. 4. Replace facings or install new driven disc assembly. 5. Install proper driven disc assembly(s). 6. Install recommended driven disc assembly properly. 7. Refer to "A" dimension chart and recheck installation. 8. Replace with new driven disc assembly. 9. Repair or replace. 10. Replace NW

COMMON SERVICE PROBLEMS (continued)

PROBLEM	REMEDY
HARD PEDAL	
<ol style="list-style-type: none"> 1. Worn pedal linkage 2. Binding in pedal linkage 3. Excessive spring pressure in cover assembly. 4. Contact pad of release bearing carrier worn by shifter yoke. 	<ol style="list-style-type: none"> 1. Replace with new linkage. 2. Lubricate and adjust. 3. Install proper cover assembly. 4. Replace carrier and shifter yoke. Also check for proper hook-up to provide best linkage operating positions.
SLIPPAGE	
<ol style="list-style-type: none"> 1. Oil or grease on facing. <p>leak.</p> <ol style="list-style-type: none"> 2. Loose or worn facings. 3. Flywheel burned, checked or cracked 4. Insufficient plate pressure 5. Improper "A" dimension (Type ML only). 6. Binding in pedal linkage 7. Improper facing material 	<ol style="list-style-type: none"> 1. Replace facing or install new driven disc assembly and correct oil 2. Replace facings or install new driven disc assembly. 3. Replace or regrind. 4. Install new cover assembly. 5. Refer to "A" dimension chart for Type ML. Adjust to correct setting. 6. Lubricate and adjust. 7. Use correct facing or replace disc assembly.
VIBRATION	
<ol style="list-style-type: none"> 1. All or part of power train out of balance. 2. One or more units in power train out of alignment. 3. Worn splined shaft 4. Worn crankshaft bearings 5. Worn or loose engine mounts 6. Loose or out of balance universal joint. 7. Clutch out of balance 8. Worn disc splines 	<ol style="list-style-type: none"> 1. Check each unit individually and recheck as a complete assembly. 2. Check and align (replace faulty component). 3. Replace. 4. Replace. 5. Replace or tighten. 6. Tighten or replace - check for balance. 7. Install balance unit. 8. Replace disc.

SUMMARY OF PROBLEMS AND SOLUTIONS - Generally if the flywheel, engine mounts, transmission shaft, and power train are all installed properly and operating correctly, then the correct clutch, properly installed, will do the job in the vehicle.

Single-Reduction Hypoid Drive Unit. (Illus. 4-45).

DISASSEMBLY.

1. Remove Drive Unit From Housing.
 - A. Remove plug from bottom of axle housing and drain lubricant.
 - B. Remove the axle shaft stud nuts, lockwashers and tapered dowels.

NOTE

TO LOOSEN THE DOWELS, HOLD A 1 1/2 INCH DIAMETER BRASS DRIFT AGAINST THE CENTER OF THE AXLE SHAFT HEAD, INSIDE THE CIRCULAR DRIVING LUGS. STRIKE THE DRIFT A SHARP BLOW WITH A 5 TO 6 POUND HAMMER OR SLEDGE. A 1 1/2 INCH DIAMETER BRASS HAMMER IS AN EXCELLENT AND SAFE DRIFT.

CAUTION

DO NOT HIT THE CIRCULAR DRIVING LUGS ON THE SHAFT HEAD - THIS MAY CAUSE THE LUGS TO SHATTER AND SPLINTER. DO NOT USE CHISELS OR WEDGES TO LOOSEN THE SHAFT OR DOWELS - THIS WILL DAMAGE THE HUB, SHAFT AND OIL SEAL.

- C. Remove the axle shaft from the drive unit and housing.
- D. Disconnect the forward and rear propeller shafts.
- E. Remove carrier to housing stud nuts and lock washers. Loosen two top nuts but leave on studs to prevent carrier from falling.
- F. Break carrier loose from housing with a rawhide mallet.
- G. To remove carrier from housing, place roller jack under carrier. Remove top nuts and lock washers and work carrier free. A small pinch bar may be used to straighten carrier in housing bore. However, the end must be rounded to prevent indenting the carrier flange.

- H. Place carrier in suitable holding fixture as illustrated. Prints of carrier repair stand are available upon request.

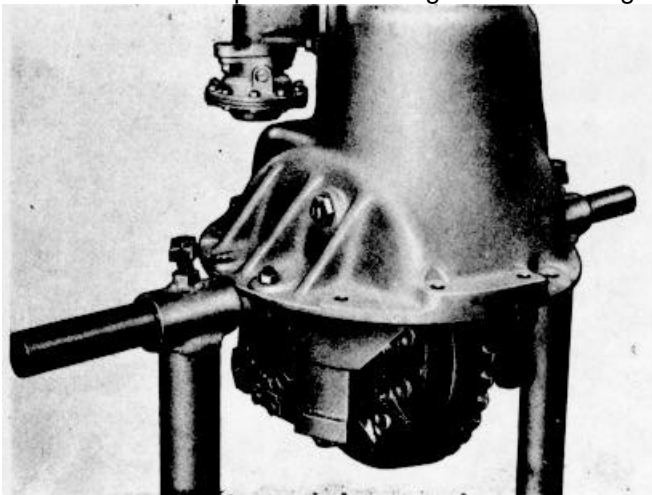

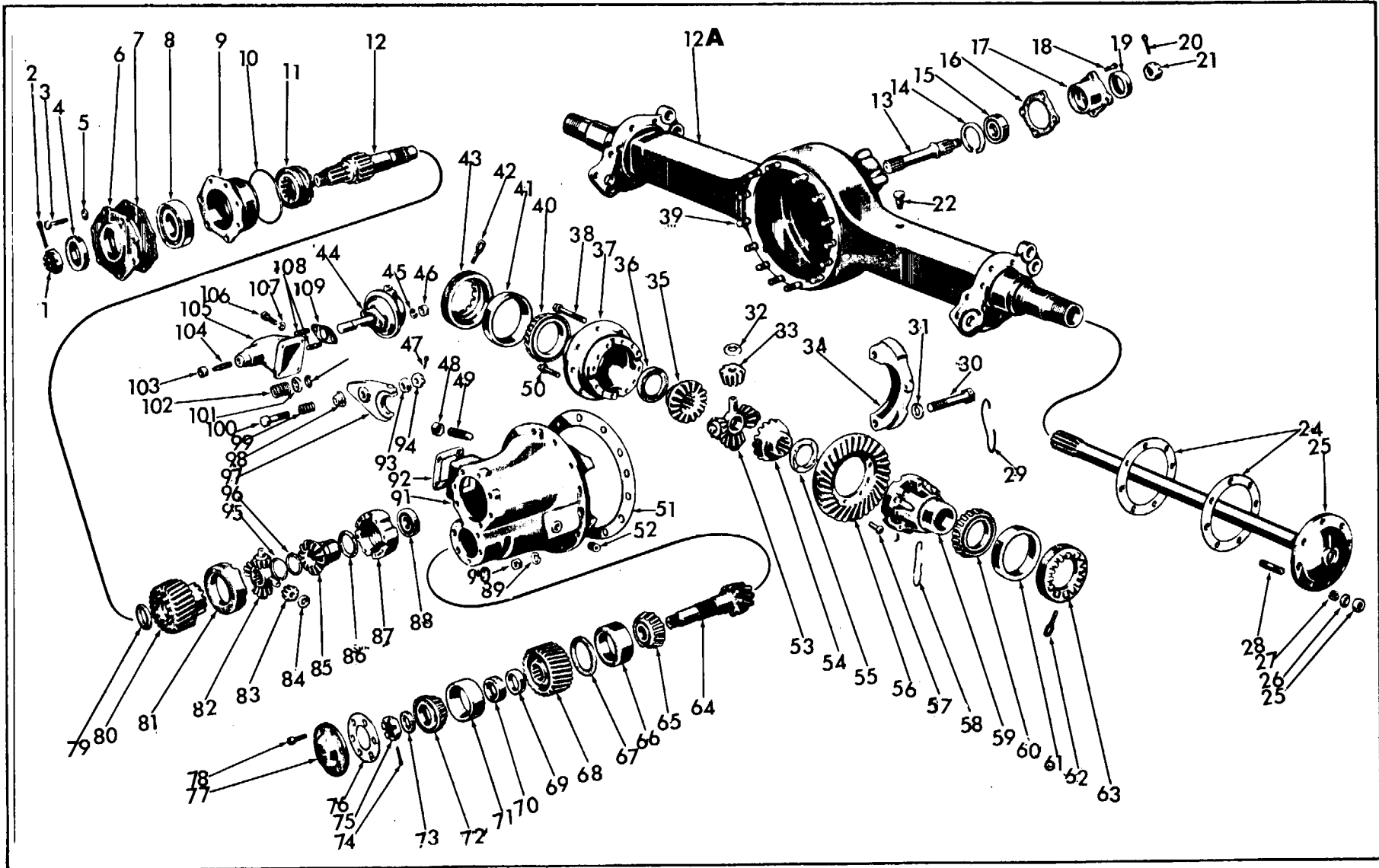
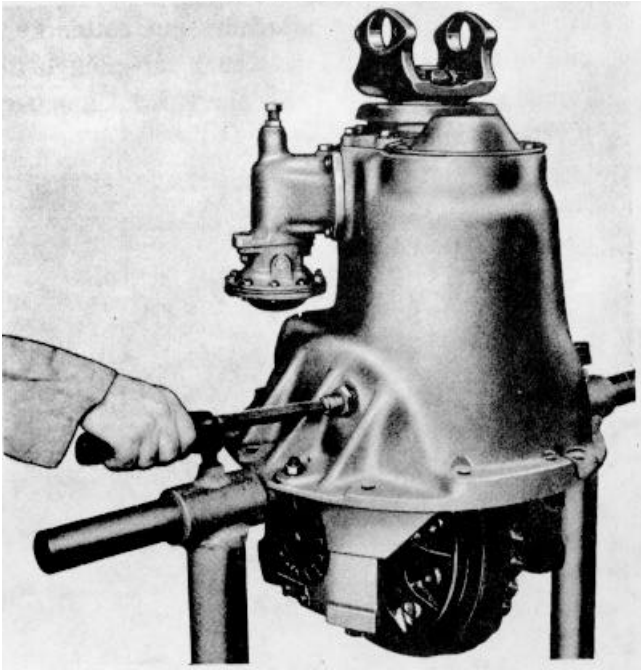

Illustration 4-45. Single-Reduction Hypoid Drive Unit.

- | | |
|---------------------------------|--|
| 1. Nut | 55. Side Gear Thrust Washer |
| 2. Cotter Key | 56. Diff. Drive Gear |
| 3. Capscrew | 57. Gear to Case Rivet |
| 4. Oil Seal | 58. Lockwire |
| 5. Washer | 59. Diff. Case (Plain Half) |
| 6. Seal Assembly Cover | 60. Diff Brg. |
| 7. Gasket | 61. Brg. Cup |
| 8. Bearing | 62. Cotter Key |
| 9. Input Shaft Brg. Cage | 63. Brg Adjustment Ring |
| 10. O Ring | 64. Diff. Drive Pinion |
| 11. Clutch Collar | 65. Inner Pinion Brg |
| 12. Input Shaft | 66. Inner Cup |
| 12A Axle Hsg | 67. Shim |
| 13. Thru Shaft | 68. Drive Gear |
| 14. Snap Ring | 69. Gear Spacer |
| 15. Ball Brg | 70. Brg Spacer |
| 16. Gasket | 71. Outer Cup |
| 17. Thru Shaft Rear Brg Cage | 72. Outer Pinion Brg. |
| 18. Capscrew | 73. Washer |
| 19. Oil Seal | 74. Cotter Key |
| 20. Cotter Key | 75. Nut |
| 21. Nut | 76. Gasket |
| 22. Breather Assy | 77. Pinion Bearing Cover |
| 23. Gasket | 78. Capscrew |
| 24. Axle Shaft | 79. Thrust Washer |
| 25. Nut | 80. Driven (Transfer) Gear |
| 26. Washer | 81. Inter Axle Diff. Case (Small Half) |
| 27. Dowel | 82. Inter-Axle Diff. Spider |
| 28. Stud | 83. Inter-Axle Diff Pinion |
| 29. Lockwire | 84. Diff. Pinion Thrust Washer |
| 30. Diff Bearing Cap Capscrew | 85. Inter-Axle Diff Side Gear |
| 31. Washer | 86. Side Gear Thrust Washer |
| 32. Diff Pinion Thrust Washer | 87. Inter-Axle Diff. Case |
| 33. Diff. Pinion | 88. Inter-Axle Diff Bearing |
| 34. Bearing Cap | 89. Lock Washer |
| 35. Diff. Side Gear | 90. Nut |
| 36. Side Gear Thrust Washer | 91. Carrier Case |
| 37. Diff Case (Flanged Half) | 92. Gasket |
| 38. Diff Case Bolt (Long) | 93. Ball |
| 39. Carrier to Hsq. Stud | 94. Nut |
| 40. Diff. Brg | 95. Snap Ring Retainer |
| 41. Brg. Cup | 96. Snap Ring |
| 42. Cotter Key | 97. Fork and Yoke Assy |
| 43. Brg. Adjusting Ring | 98. Seat Washer |
| 44. Inter-axle Diff. Shift Unit | 99. Spring |
| 45. Lock Washer | 100. Bolt |
| 46. Nut | 101. Spring Retainer |
| 47. Cotter Key | 102. Spring |
| 48. Jam Nut | 103. Nut |
| 49. Thrust Screw | 104. Stop Screw |
| 50. Diff. Case Bolt (Short) | 105. Shift Housing |
| 51. Gasket | 106. Capscrew |
| 52. Plug | 107. Lock Washer |
| 53. Diff. Spider | 108. Studs |
| 54. Diff Side Gear | 109. Gasket |



- J. Loosen jam nut and back off thrust block adjusting screw. Roll differential gear slightly to allow thrust block to drop out.

2. Remove and Disassemble Shift Unit Housing Assembly.

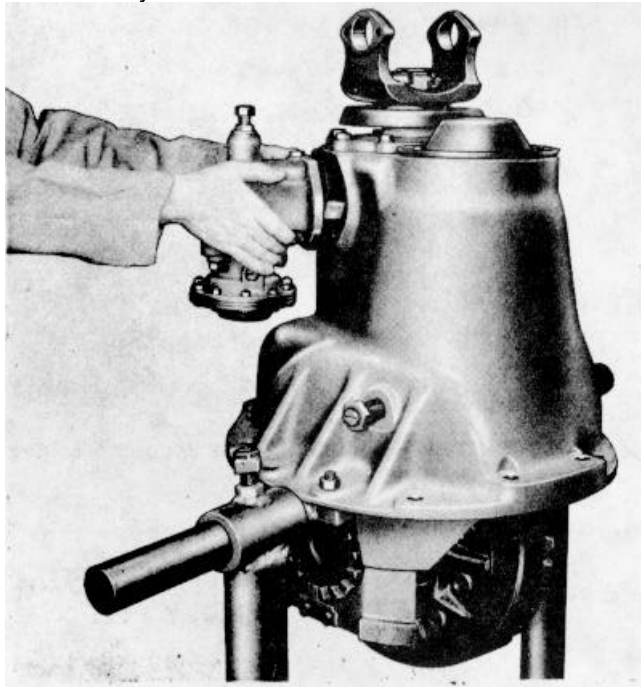

- A. Remove the shift housing cap screws and lock washers.

B. Remove the shift housing assemble and gasket.

C. To disassemble the shift housing assemble remove the shift lever attaching nut cotter key and nut. Tap body fit bolt back far enough to remove lever from shift shaft slot. Remove lever cup and spring.

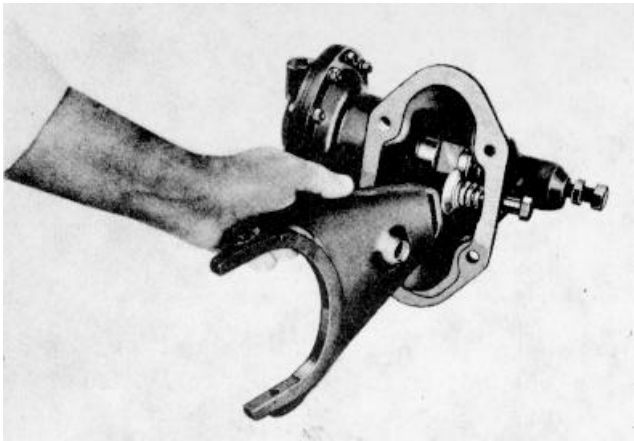

- D. Remove the shift chamber attaching nuts and lock washers. By use of snap ring pliers, expand lock ring to clear shaft groove and slide out shaft and chamber assembly.

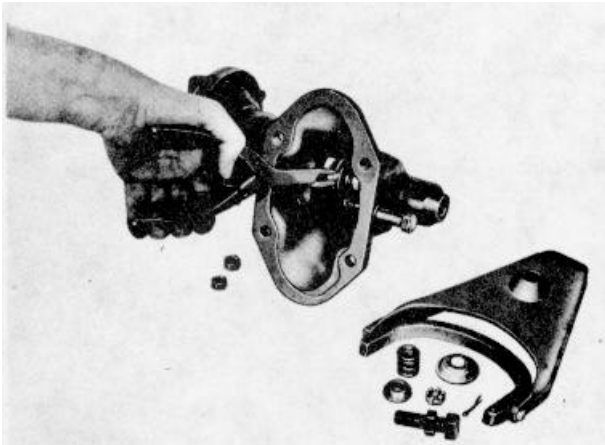

- E. Remove from the housing the spring retainer and spring.

- 3. Remove Inter-Axle (3rd) Differential and Cage Assembly. Before disassembly is started, record gear backlash. Gear must be reset to this figure at reassembly.

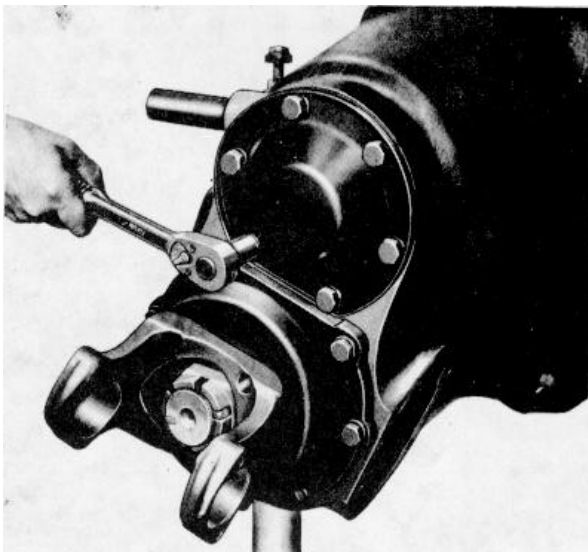

- A. Remove the pinion bearing cover cap screws and lock washers. Remove cover and gasket.

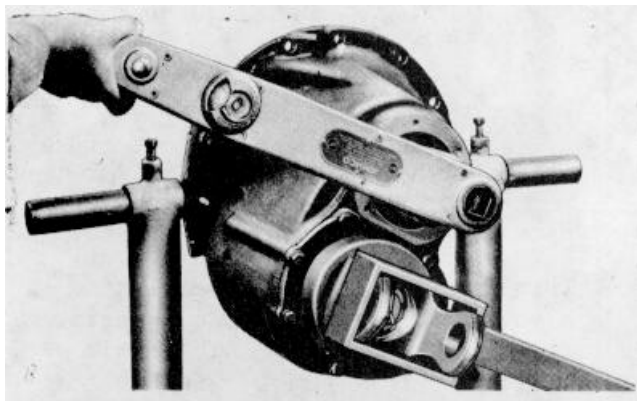

- B. Remove pinion nut cotter key and loosen pinion nut. (Do not remove pinion nut at this time).

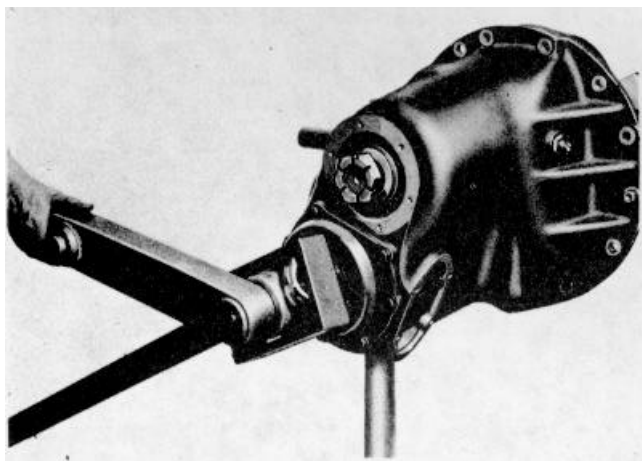

- C. Remove input shaft cotter key and loosen yoke or flange nut. (Do not remove nut at this time).

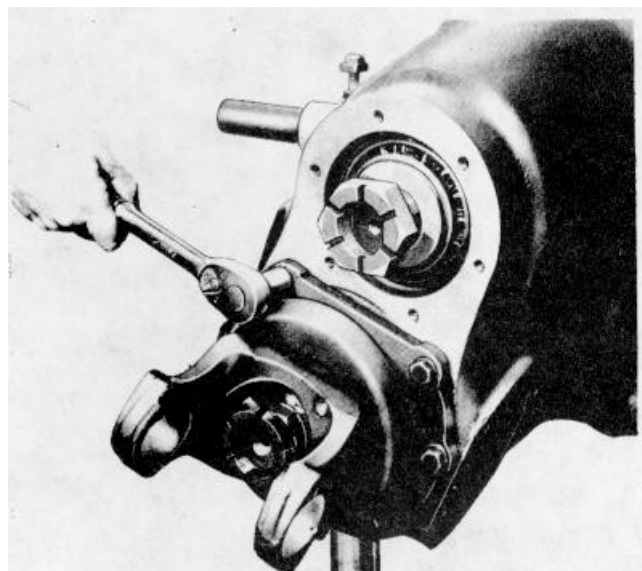

- D. Remove the input shaft cage cap screws and lock washers.

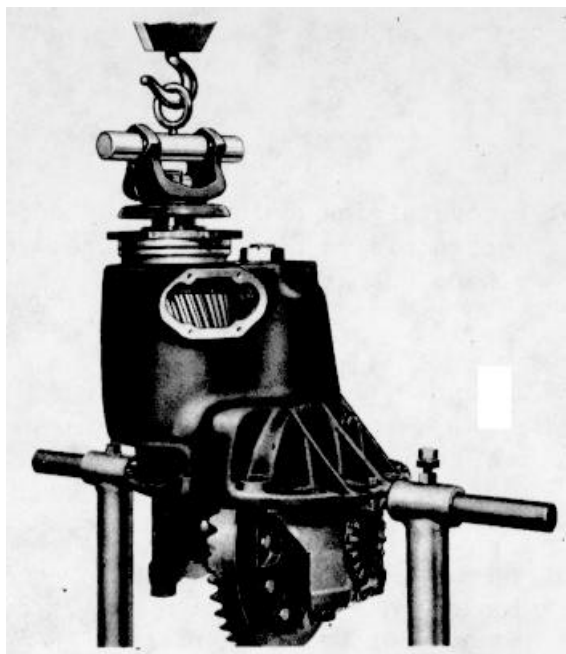

- E. Turn the drive unit assembly to a vertical position in the carrier stand and remove the inter-axle differential assembly with a chain fall.

4-236

F. Lightly tap housing with rawhide hammer to free assembly. It may be necessary to rotate the input shaft to align one flat at rear of inter-axle differential case with the transfer gear.

4. Remove Differential and Gear Assembly.

A. Cut lock wire. Remove cap screws and adjusting nut locks.

B. Center punch one differential carrier leg and bearing cap to identify for properly reassembling.

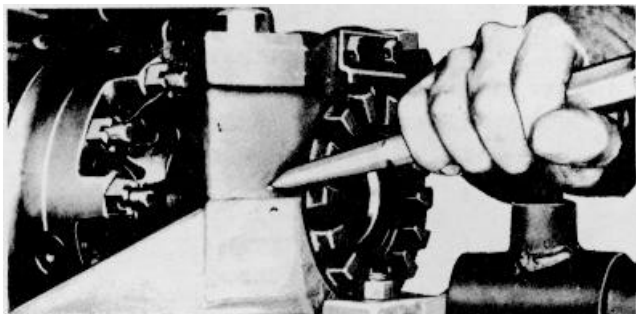

C. Remove bearing cap stud nuts or cap screws, bearing caps and adjusting nuts.

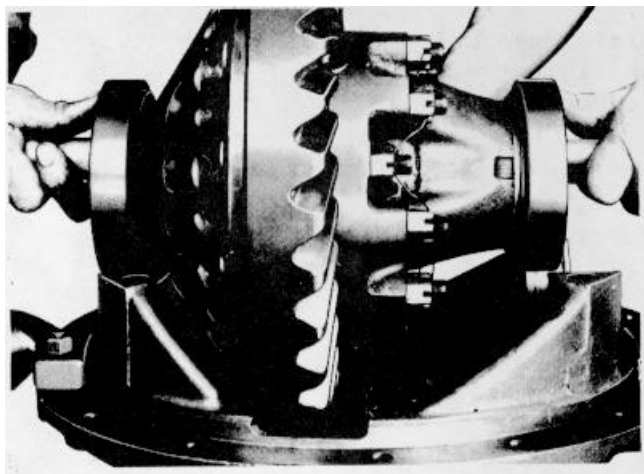

D. Lift out differential and gear assembly.

5. Disassemble Differential Case and Gear Assembly.

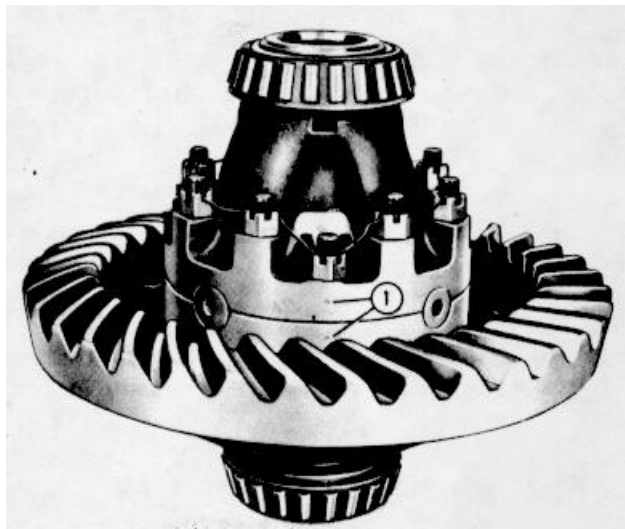

A. If original identification marks are not clear, mark differential case halves with a punch or chisel for correct alignment on reassembling.

- B. Cut lock wire, remove bolts and separate case halves.
- C. Remove spider, pinions, side gears and thrust washers.
- D. remove rivets and separate gear and case.

1. Carefully center punch rivets in center of head.

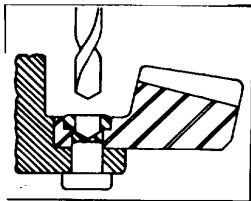

RIGHT

2. Use drill 1/32" smaller than body of rivet to drill through head.

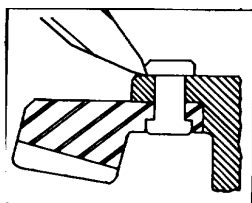

WRONG

3. Press out rivets.

E. If necessary to replace differential bearings, remove with

6. Remove pinion Assembly.

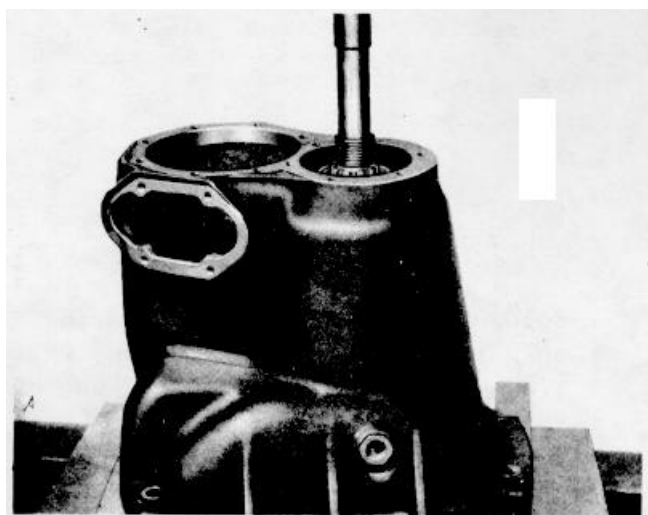

- A. Position the drive unit in a press supported by press plates under the carrier to housing mounting flange.

- B. Remove the pinion nut (previously loosened) and spacing washer.

- C. Press the pinion shaft through the forward pinion bearing cone and drive gear.
- D. Lift out the forward pinion bearing cone and two spacers. Remove the drive gear and pinion. (Remove the drive gear spacer from the pinion shaft not used on all models).
- E. Remove the forward pinion bearing cup with suitable puller.
- F. Remove the rear pinion bearing cup with a suitable puller and remove the cup spacer and shim pack. (Spacer not used on all models).
- G. Wire the shim pack together to facilitate reassembly.

NOTE

THIS SHIM PACK CONTROLS THE DEPTH OF PINION IN RELATION TO THE HYPOID GEAR AND IT MAY BE INCREASED OR DECREASED TO CHANGE THE TOOTH CONTACT AT TIME OF REASSEMBLY.

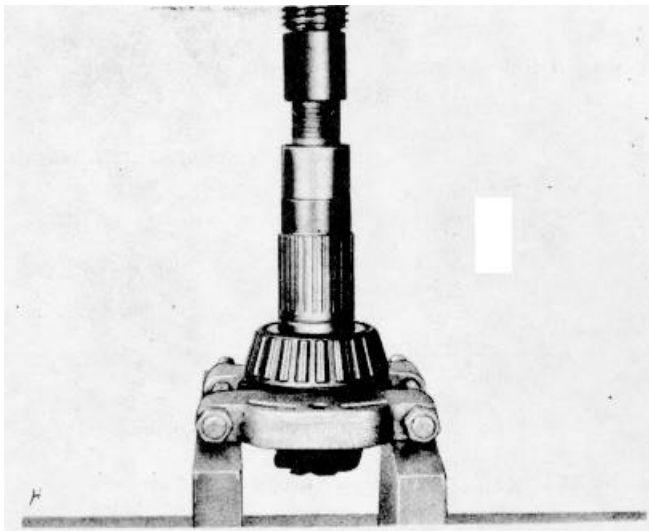

- H. If necessary to remove the rear pinion bearing, use a suitable puller that bears against bearing inner race or press off with a fixture that supports inner race.

- 7. Disassemble Inter-Axle (3rd) Differential Assembly.

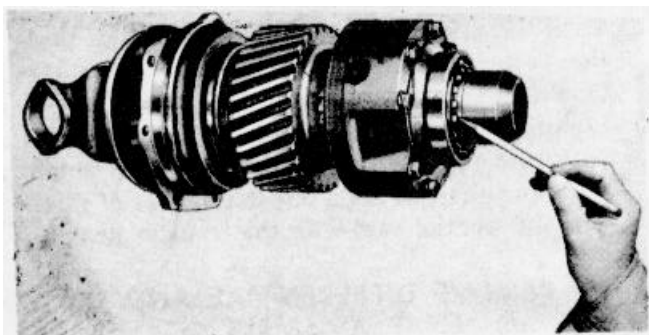

- A. Fold out the tabs on rear bearing snap ring retainer and remove snap ring with snap ring pliers. Remove snap ring retainer.

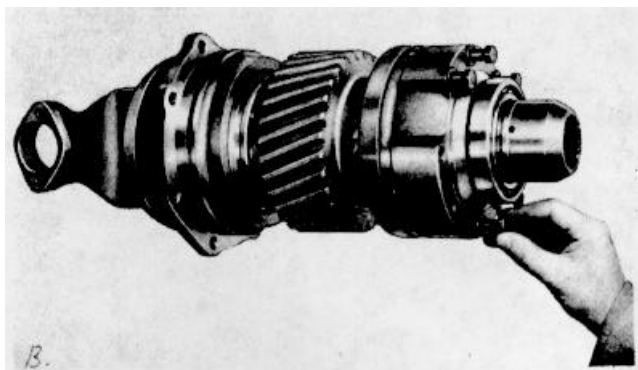

- B. Cut and remove the inter-axe case bolt locking wire. Remove the case bolts and hardened washers. Center punch each case half before separating to insure correct alignment in reassembly.

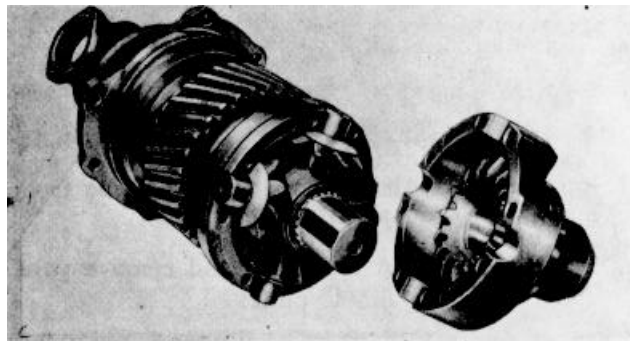

- C. Separate the inter-axe differential case halves.

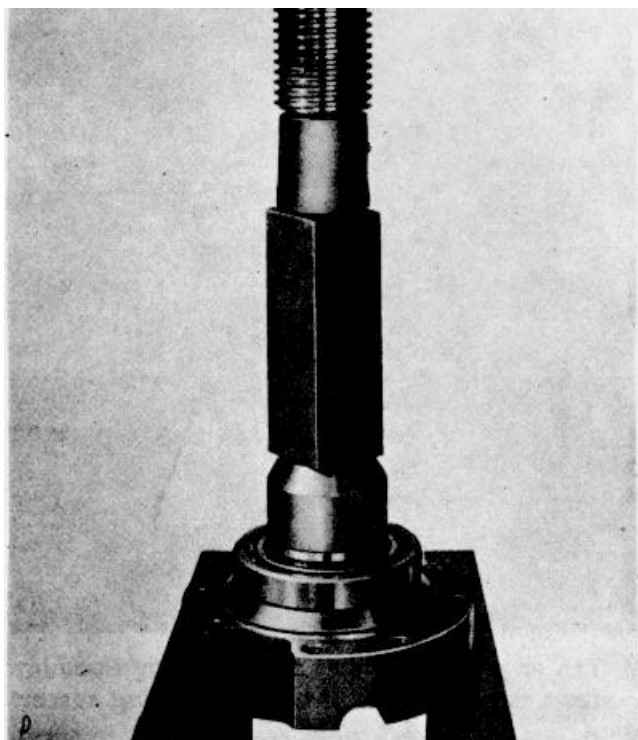

- D. Set the rear case half up on press plates and press the rear side gear from bearing.

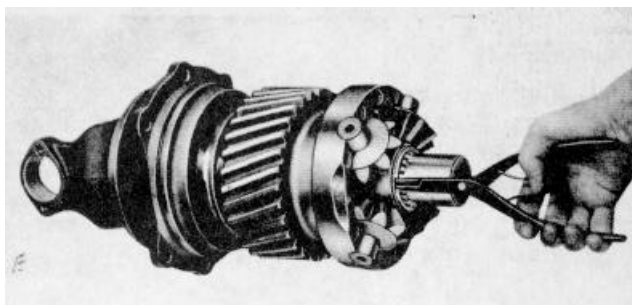

- E. Push spider and snap ring retainer forward and remove snap ring with snap ring pliers. Slide off snap ring retainer.

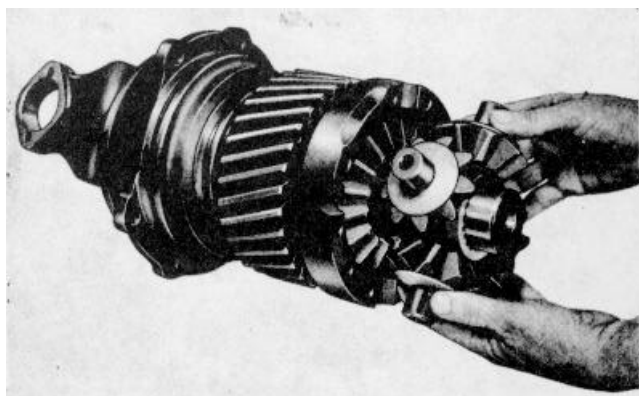

- F. Slide spider, pinion and thrust washer assembly off shaft splines.

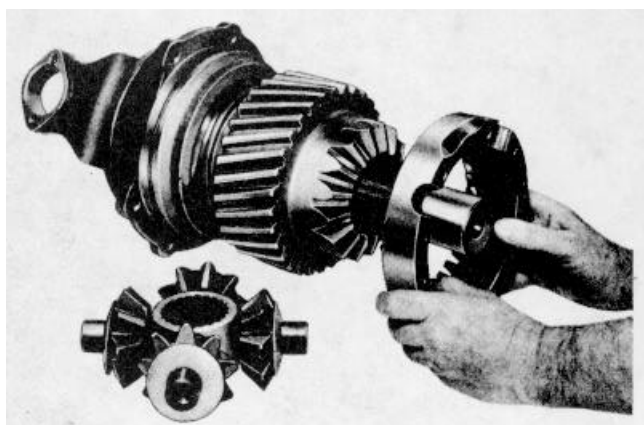

- G. Remove the inter-axle differential forward case half.



- H. Separate the inter-axle differential pinions and thrust washers from spider.

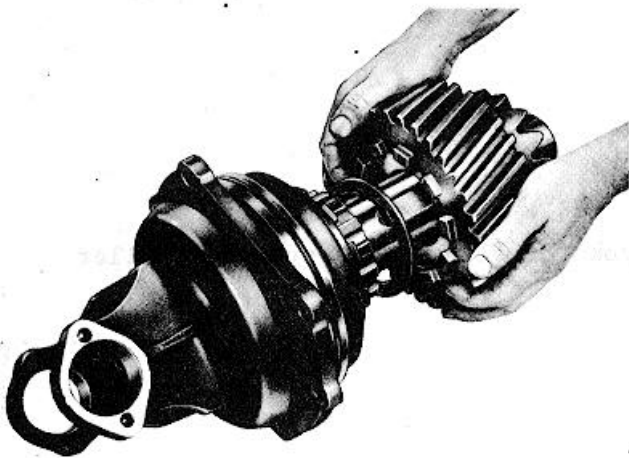

- I. Remove the transfer gear and thrust washer from input shaft. (Transfer gear and forward side gear are integral).

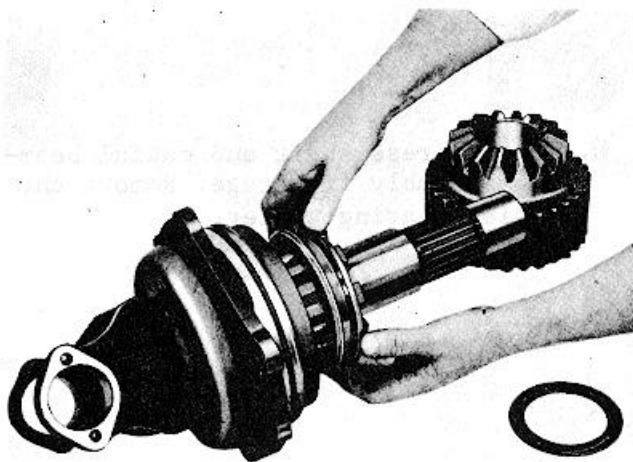

- J. Slide off the clutch collar.

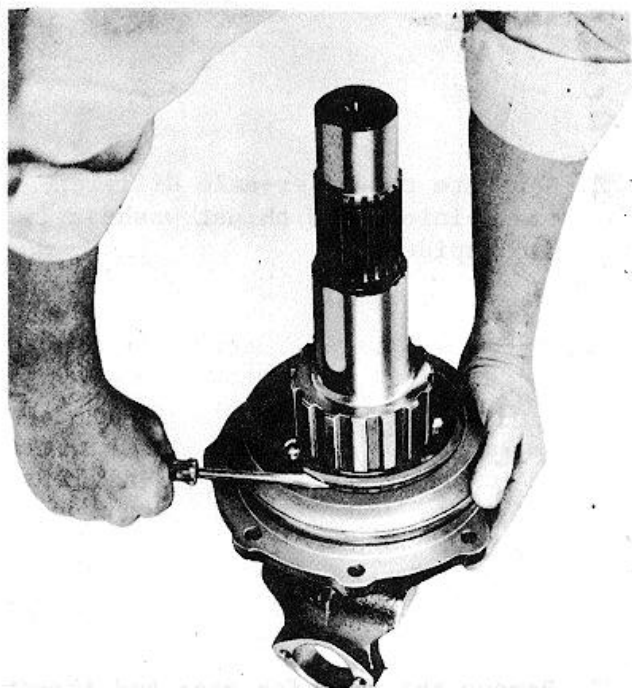

- K. Remove the radial bearing rear snap ring from bearing cage.

- L. Remove the input shaft nut and remove yoke or flange with suitable puller.

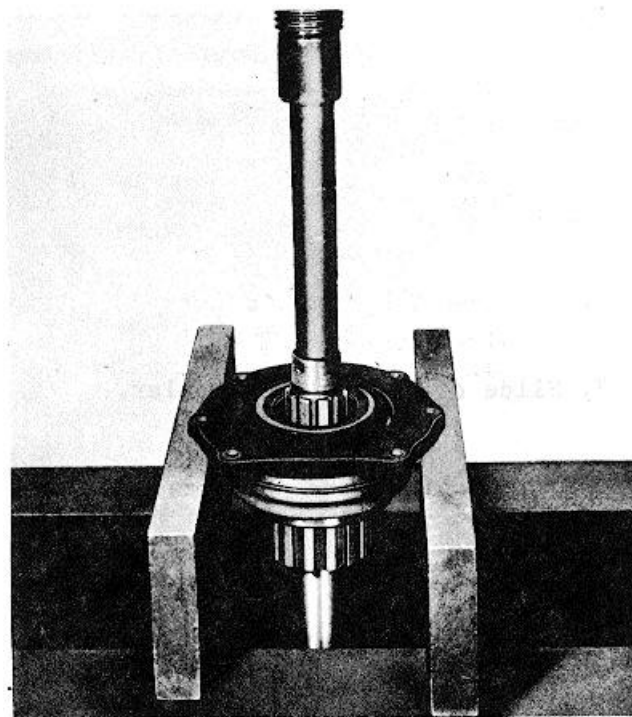

- M. Tap or press shaft and radial bearing assembly from cage. Remove the radial bearing spacer.

- N. Remove snap ring from cage.

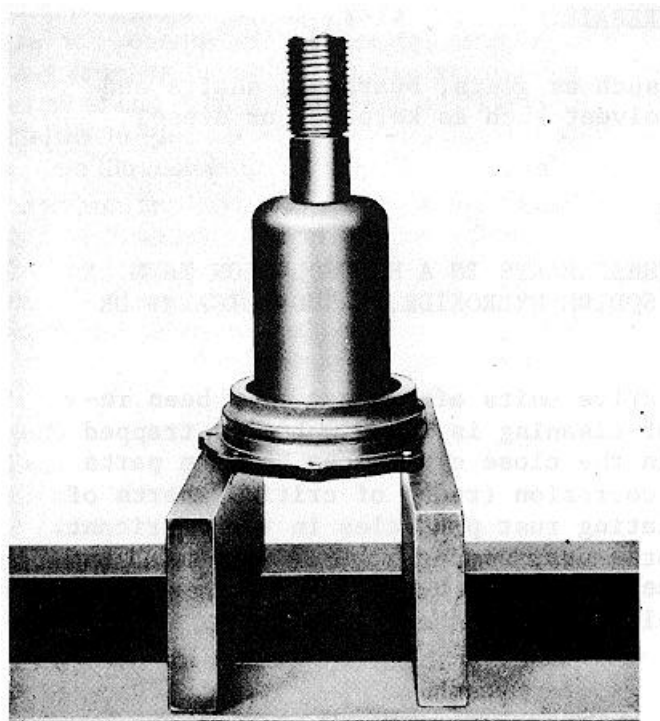

- O. Press out the oil seal with a suitable sleeve and discard.

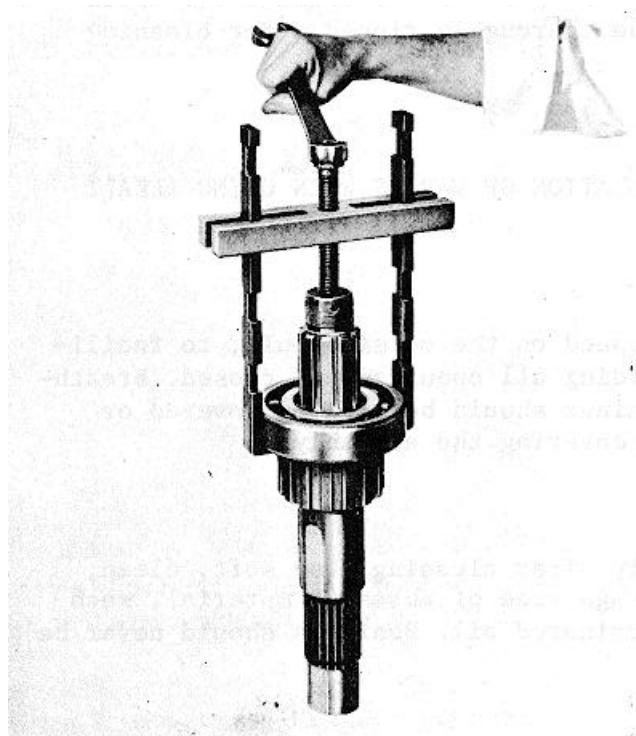

- P. Remove the radial bearing with a suitable puller equipped with fingers that bear against inner race.

PREPARE FOR REASSEMBLY CLEAN, INSPECT AND BEPATR.

Parts having ground and polished surfaces such as gears, bearings, shafts and collars, should be cleaned in a suitable solvent such as kerosene or diesel fuel oil.

CAUTION

GASOLINE SHOULD BE AVOIDED. DO NOT CLEAN THESE PARTS IN A HOT SOLUTION TANK OR WITH WATER AND ALKALINE SOLUTIONS SUCH AS SODIUM HYDROXIDE, ORTHOSILICATES OR PHOSPHATES.

Do not recommend steam cleaning assembled drive units after they have been removed from the housing. When this method of cleaning is used, water is trapped in the cored passage of the castings and in the close clearances between parts as well as on the parts. This can lead to corrosion (rust) of critical parts of the assembly and the possibility of circulating rust particles in the lubricant. Premature failure of bearings, gears and other parts can be caused by this practice. Assembled drive units cannot be properly cleaned by steam cleaning, dipping or slushing. Complete drive unit disassembly is a necessary requisite to thorough cleaning.

Rough Parts.

Rough parts such as differential carrier castings, cast brackets and some brake parts may be cleaned in hot solution tanks with mild alkali solutions providing these parts are not ground or polished. The parts should remain in the tank long enough to be thoroughly cleaned and heated through. This will aid the evaporation of the rinse water. The parts should be thoroughly rinsed after cleaning to remove all traces of alkali.

CAUTION

EXERCISE CARE TO AVOID SKIN RASHES AND INHALATION OF VAPORS WHEN USING ALKALI CLEANERS.

Complete Assemblies.

Completely assembled axles may be steam cleaned on the outside only, to facilitate initial removal and disassembly, providing all openings are closed. Breathers, vented shift units, and all other openings should be tightly covered or closed to prevent the possibility of water entering the assembly.

Drying.

Parts should be thoroughly dried immediately after cleaning. Use soft, clean, lintless absorbent paper towels or wiping rags free of abrasive material, such as lapping compound, metal filings or contaminated oil. Bearings should never be dried by spinning with compressed air.

Corrosion Prevention.

Parts that have been cleaned, dried, inspected and are to be immediately reassembled should be coated with light oil to prevent corrosion. If these parts are to

be stored for any length of time, they should be treated with a good RUST PREVENTIVE and wrapped in special paper or other material designed to prevent corrosion.

INSPECT.

It is impossible to overstress the importance of careful and thorough inspection of drive unit parts prior to reassembly. Thorough visual inspection for indications of wear or stress, and the replacement of such parts as are necessary will eliminate costly and avoidable drive unit failure.

1. Inspect all bearings, cups and cones, including those not removed from parts of the drive unit, and replace if rollers or cups are worn, pitted or damaged in any way. Remove parts needing replacement with a suitable puller or in a press with sleeves. Avoid the use of drifts and hammers. They may easily mutilate or distort component parts.
2. Inspect hypoid or spiral bevel gears for wear or damage. Gears which are worn, ridged, pitted or scored, should be replaced. When necessary to replace either the pinion or gear of hypoid set, the entire gear set should be replaced.
3. Inspect the differential assembly for the following:
 - A. Pitted, scored or worn thrust surfaces of differential case halves, thrust washers, spider trunnions and differential gears. Thrust washers must be replaced in sets. The use of a combination of old and new washers will result in premature failure.
 - B. Wear or damage to the differential pinion and side gear tooth. Always replace differential pinions and side gear teeth. Always replace differential pinions and side gears in sets.
4. Inspect axle shafts for signs of torsional fractures or other indication of impending failure.

REPAIR.

1. Replace all worn or damaged parts. Hex nuts with rounded corners, all lock washers, oil seals and gaskets should be replaced at the time of overhaul.

Use only genuine Rockwell-Standard replacement parts for satisfactory service. For example, using gaskets of foreign material generally leads to mechanical trouble due to variations in thickness and the inability of certain materials to withstand compression, oil, etc.
2. Remove nicks, mars and burrs from machined or ground surfaces. Threads must be clean and free to obtain accurate adjustment and correct torque. A fine mill file or India stone is suitable for this purpose. Studs must be tight prior to reassembling the parts.
3. All Rockwell-Standard bronze bushed differential pinions should be ball burnished after bushing installation. Install the bushing with a small stepped drift, The small O.D. should be .010" smaller than the bushing burnished I.D. and 1 1/2 times bushing length. Always install bushings so end is even with the I.D. chamfer or about 1/16" below the spherical surface.

4. When assembling component parts use a press where possible.
5. Tighten all the nuts to the specified torque. (See torque limits following service instructions). Use soft iron locking wire to prevent possibility of wire breakage.
6. The burrs, caused by lockwashers, at the spot face of stud holes of cages and covers should be removed to assure easy reassembly of these parts.

REASSEMBLY.

NOTE

SEE TABLE 4-1 FOR TORQUE VALUES TO BE USED DURING REASSEMBLY.

1. Assemble Hypoid Pinion.



- A. Press the rear cone squarely and firmly against the pinion head. Use a suitable sleeve that will bear against cone race.

- B. Prior to assembling the rear bearing cup, spacer and shim pack (install gear spacer if used), note following: If original gears and rear bearings are reused, install original shim pack. If gears have been replaced, alter the original shim pack as follows: Note the variation from the nominal assembly dimension on both the old and new pinion. (The nominal dimension is stamped and the variation is etched on the "nose" of the pinion). Increase or reduce the shim pack in accordance with the change in the variation from the old to the new pinion. After changing the sign of the old variation plus to minus or minus to plus add to the new variation (sign unchanged). The answer will be increase or decrease of the original shim pack in thousandths of an inch.

EXAMPLE:

Old Pinion Marked
3.125 + 6

New Pinion Marked
3.125 + 2

First, we change the sign of the variation of the old pinion (+) which changes the variation from +6 to -6. Then we add -6 to the variation of the new pinion, +2, which gives us an answer of -4. This means that we must add .004" from the shim pack used with the old pinion.

- C. Install rear bearing cup against the shim pack (and spacer, if used).
- D. Install the outer pinion bearing cup to bottom in cup bore.
- E. Lubricate bearing and cups with light machine oil.
- F. Place the carrier and cap under a press, carrier legs down. Hold transfer _ gear in position and thread pinion shaft up through inner bearing cup and

TABLE 4-1. SINGLE REDUCTION HYPOID - DRIVE UNIT TORQUE LIMITS







<u>NOMENCLATURE</u>	<u>BOLT SIZE</u>		<u>TORQUE LIMITS LB. FT.</u>
Diff. Case Capscrew Long and Short	9/16"-12		130-170
	5/8"-11		185-235
	9/16"-12		130-170
	5/8"-11		185-235
Diff. Bearing Cap to Carrier Capscrew	7/8"-9		470-520
	1"-14		470-520
	7/8"-9V		470-550
	1"-14		470-550
Rear Bearing Cage Capscrew	3/8"-16		30-40
	3/8"-24		35-50
	7/16"-14		60-75
Thru Shaft (Output) Yoke or Flange Nut	1 1/2"-18		300-400
	1 1/2"-18		500-600
Thrust Screw Jam Nut	7/8"-14		145-190
Air Chamber to Shift Housing Stud Nut	3/8"-24		30-40
Shift Housing to Carrier Capscrew	3/8"-16		30-40
Shift Shaft Adjusting Screw Locknut	1/2"-20		45-60
Shift Yoke Nut and Bolt			Tighten Nut to Seat Spherical Washer Against Shoulder. Back Off if Necessary to Line Up with Cotter Pin Hole
	3/8"-24		20-30
Input Bearing Cage Capscrew	7/16"-14		40-55
Input Shaft Yoke or Flange Nut	1 3/4"-12		300-400
	1 3/4"-12		500-600
Inter-Axle Diff. Case Bolt	7/16"-14		60-75
	1/2"-20		90-120
Pinion Cage Cover Screw	3/8"-16		25-40
	3/8"-24		35-50
Pinion Shaft Nut	1 3/4"-12 1/2		800-1100
	1 3/4"-12		900-1200

TABLE 4-1. SINGLE REDUCTION HYPOID - DRIVE UNIT TORQUE LIMITS (continued)

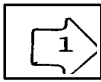
<u>NOMENCLATURE</u>	<u>BOLT SIZE</u>		<u>TORQUE LIMITS LB.FT.</u>
Carrier to Housing Stud Nuts	1/2"-20 5/8"-18 3/4"-16		80-105 160-205 290-370
Inspection Hole Plug			Thread into Carrier and Allow One Thread Standout
Adjusting Ring Lock (Specified Models Only)			
Adjusting Ring Lock to Diff. Bearing Cap Capscrews	5/16"-18 5/16"-18		15-20 22-28

NOTES

FOR ALL FASTENERS

ALL TORQUES GIVEN APPLY TO PARTS COATED WITH MACHINE OIL.

FOR DRY PARTS INCREASE TORQUES 10%.

FOR PARTS COATED WITH MULTI-PURPOSE.

GEAR OIL DECREASE TORQUE 10%.

NUTS ON STUDS TO USE THE SAME TORQUE AS FOR DRIVING THE STUD.



INDICATES TORQUE VALUES FOR FASTENERS USING LOCKWIRE OR COTTER PINS.

ALL OTHER TORQUE VALUES ARE FOR FASTENERS NOT USING LOCKWIRE OR COTTER PINS.

transfer gear. Support pinion and carrier under pinion head. Install "fixed" (thick) cone spacer.

- G. Start outer bearing cone on pinion shaft. Press bearing on with a suitable sleeve that will bear against the cone race. Press bearing in place with two tons pressure to seat rollers.
 - H. Assemble pinion nut washer and nut with only 100 pound feet torque. Hold pinion by placing a hardwood block between pinion teeth and carrier wall.
2. Assemble Differential and Gear.
- A. Rivet the hypoid gear to the case half with new Rockwell-Standard rivets. Rivets should not be heated, but always upset cold. When the correct rivet is used, the head being formed will be at least 1/8" larger in diameter than the rivet hole. The head will then be approximately the same height as the performed head. Excessive pressure will cause distortion of the case holes and result in gear eccentricity.

Tonnage required for squeezing cold rivets: these pressures are approximate for annealed steel rivets and pressure can be adjusted to suit individual working conditions.

Diameter of Rivet	Tonnage Required
7/16"	22
1/2"	30
9/16"	36
5/8"	45

Differential case and gear bolts are available for service replacement of rivets. The use of bolts greatly facilitates servicing these units in the field and eliminates the need for special equipment necessary to correctly cold upset rivets.

- B. Lubricate differential case inner walls and all component parts with axle lubricant.

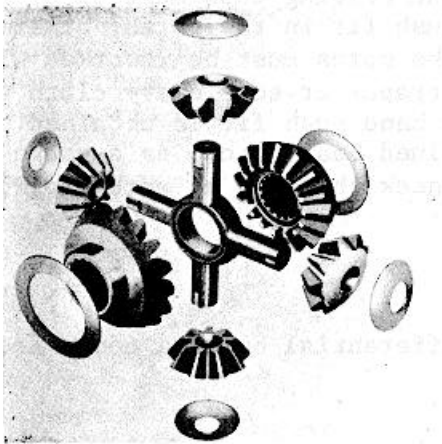

DIFFERENTIAL PINION AND SIDE GEAR ASSEMBLY

- C. Position thrust washer and side gear in bevel gear and case half assembly.

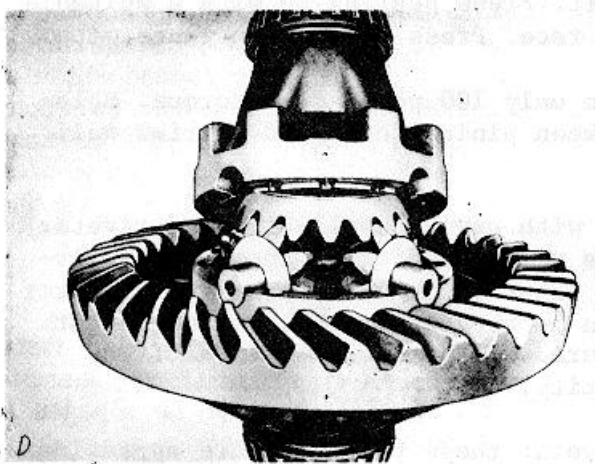

- D. Place spider with pinions and thrust washers in position.

- E. Install component side gear and thrust washer.
 F. Align mating marks, position component case half and draw assembly together with four bolts or cap screws equally spaced.
 G. Check assembly for free rotation of differential gears and correct if necessary.
 H. Install remaining bolts and cap screws, tighten to the correct torque and lock wire.
 I. If bearings are to be replaced, press squarely and firmly on differential case halves.

3. Install Bearing Cups in Carrier Leg Bores.

- A. Temporarily install the bearing cups, threaded adjusting rings where employed and bearing caps. Tighten the cap screws to the proper torque.



- B. The bearing cups must be of a hand push fit in the bores, otherwise the bores must be reworked with a scraper or some emery cloth until a hand push fit is obtained. Use a blued bearing cup as a gauge and check the fits as work progresses.

4. Install Differential and Gear Assembly.

- A. After checking related parts, coat the differential bearing cones and cups specified rear axle lubricant.

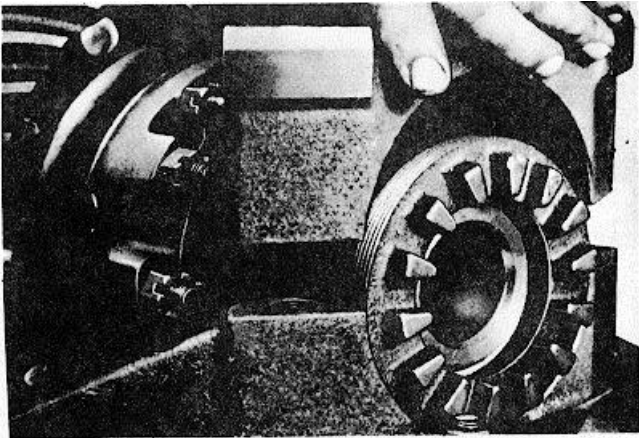

- B. Place the bearing cups over the assembled differential bearing cones, then position the differential assembly in the carrier.

- C. Insert bearing adjusting nuts and turn handtight against bearing cups.
- D. Install bearing caps in the correct location as marked and tap lightly into position.

NOTE

IF BEARING CAPS DO NOT POSITION PROPERLY, ADJUSTING NUTS MAY BE CROSS THREADED. REMOVE CAPS AND REPOSITION THE ADJUSTING NUTS. FORCING CAPS INTO POSITION WILL RESULT IN IRREPARABLE DAMAGE TO THE CARRIER HOUSING OR BEARING CAPS.

- E. Install flat washers where used and stud nuts or cap screws. Tighten stud nuts or cap screws to correct torque.
5. Adjust Differential Bearing Pre-Load.

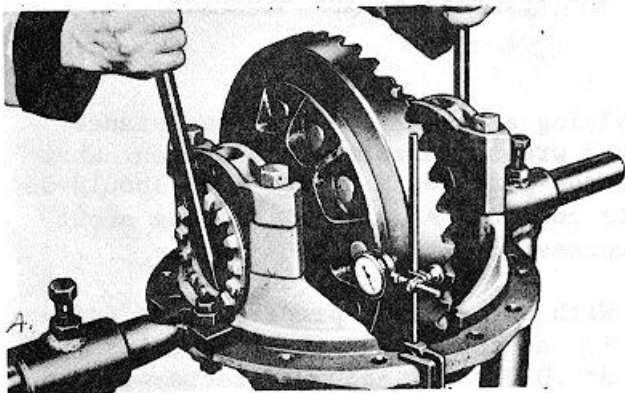

- A. Using dial indicator at backface of gear, loosen the bearing adjusting nut on the side opposite gear only sufficient to notice end play on the indicator.

- B. Tighten the same adjusting nut only sufficient to obtain .000" end play.
- C. Check gear for runout. If runout exceeds .008", remove differential and check for cause.
- D. Tighten adjusting nuts one notch each from .000" end plat to pre-load differential bearings.

6. Check Hypoid Gear Backlash.

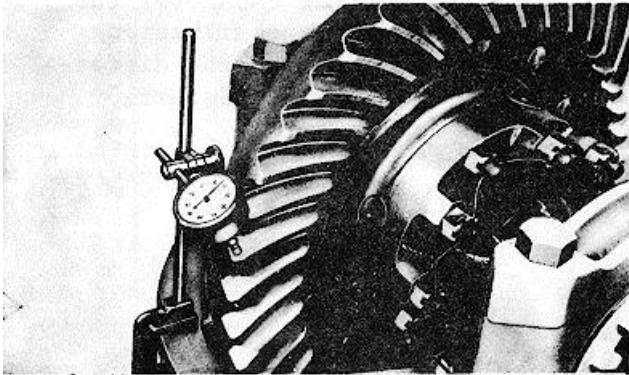

If original gears are reused the backlash should be made the same as before disassembly. For new gears the new backlash should be from .006" to .012". Adjust backlash by moving the gear only. This is done by backing off one adjusting ring and advancing the opposite ring the same amount.

7. Check Tooth Contact.

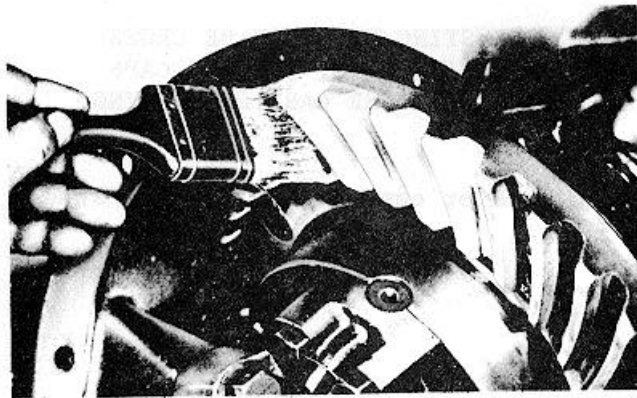

Apply oiled red lead lightly to the hypoid gear teeth. When the pinion is rotated, the red lead is squeezed away by the contact of the teeth, leaving bare areas the exact size, shape and location of the contacts.

Sharper impressions may be obtained by applying a small amount of resistance to the gear with a flat steel bar and using a wrench to rotate the pinion. When making adjustments, check the drive side of the gear teeth. Coast side should be automatically correct when the drive side is correct. As a rule, coating about twelve teeth is sufficient for checking purposes.

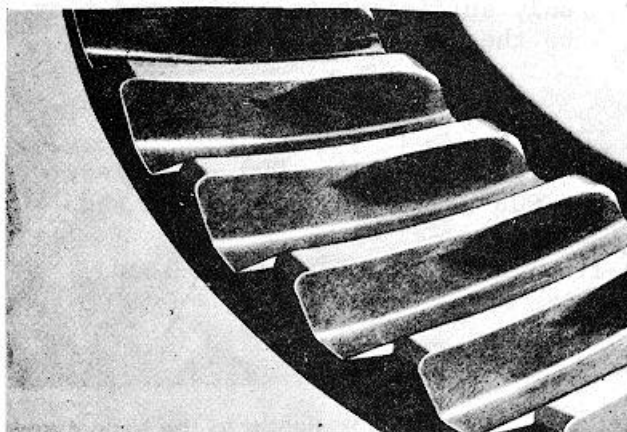

With adjustments properly made (pinion at correct depth and backlash set at .010") the above contacts will be procured. The area of contact favors the toe and is centered between the top and bottom of the tooth.

The hand rolled pattern shown at left (gears unloaded), will result in a pattern centered in the length of the tooth when the gears are under load, shown at right. The loaded pattern will be almost full length and the top of pattern will approach the top of the gear tooth

*SATISFACTORY TOOTH CONTACT.
(GEARS UNLOADED)*

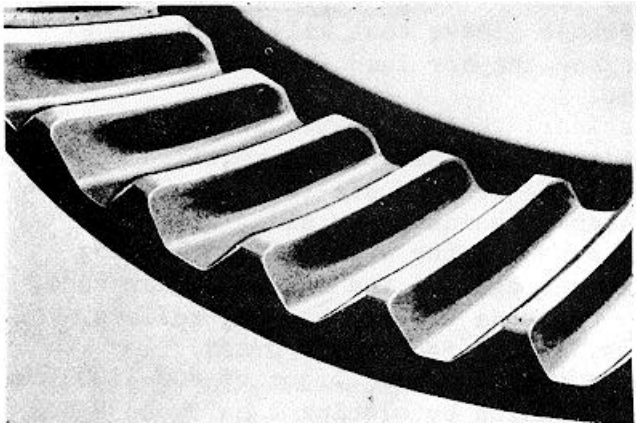

*SATISFACTORY TOOTH CONTACT
(GEARS LOADED)*

The pattern on the coast side of teeth will appear the same width as the drive side shown above; however, the over-all length will be centered between the toe and heel of gear tooth. After the correct contacts shown above have been established with a backlash of .010", open the backlash to measure between .020"-.026".

Set used hypoid gear to have the tooth contacts to match wear patterns. Hand rolled patterns of used gears will be smaller in area and should be at the toe end of wear patterns.

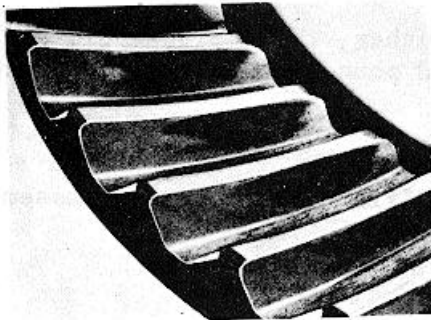

A high contact indicates pinion is too far out. Set the pinion to the correct depth by removing shims under the pinion cage. Slight outward movement of hypoid gear may be necessary x / to maintain correct backlash.

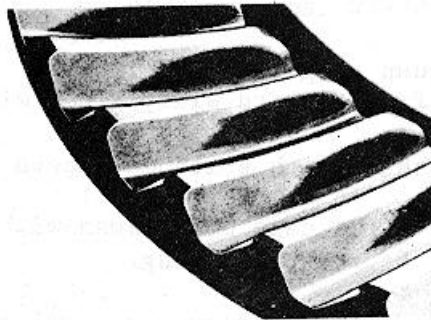

A low contact indicates pinion is too deep. Set the pinion to the correct depth by adding shims under the pinion cage. Slight inward movement of the hypoid gear may be necessary to maintain correct backlash.

8. Check for Pinion Bearing Pre-Load.

Now that the proper tooth contact and shim pack for the rear bearing cup have been determined, determine the pinion bearing pre-load.

- A. Remove the differential and gear assembly and associated parts.
- B. Remove pinion nut and washer. Press the hypoid pinion out of outer bearing cone. Press transfer gear back in position on pinion.
- C. Make sure "fixed" (thick) spacer is in position against transfer gear. Cut two lengths of bar lead (or solder) approximately 9/16" long and insert

both on top of the "fixed" spacer, 180° apart. Press bearing cone in place with two tons pressure and with a suitable sleeve that will bear against NJ the cone race. This process will compress the bar lead (or solder).

- D. Press pinion out of outer bearing cone.
- E. Measure the compressed bar lead (or solder) thickness with a micrometer. To this figure add .004" to determine the thickness of the required variable spacer to be employed to obtain pinion bearing pre-load.
- F. Install variable spacer over pinion stem against gear side.
- G. Place a support under pinion head and press on the outer pinion bearing cone with a suitable sleeve that will bear against the bearing inner race. Apply press pressure of approximately two tons to seat bearing rollers. Rotate carrier and cap in this process. Remove from under press.
- H. Assemble pinion washer and nut. Tighten to specified torque of 800-1100 pound feet. To apply proper torque hold pinion by placing a hardwood block between pinion teeth and carrier wall.
- I. Check for proper pinion bearing pre-load of 5-15 pound inches by installing appropriate wrench socket over pinion nut. Wrap a cord or soft wire around socket and pull on horizontal line with a pound "fish" scale. Use rotating torque, not starting torque. If rotating torque is not within 5 to 15 pound inches, use thinner hardened spacer to increase, or thicker spacer to decrease, pre-load.

EXAMPLE: Assuming socket diameter to be 4 inches, the radius would be 2 inches and with 5 pounds pull would equal 10 pound inches pre-load torque.

9. Reassemble Differential and Gear Assembly.

Follow instructions as before for installing the differential and gear assembly $\frac{1}{4}$) in subsequent steps:

- 1. Adjust for differential bearing pre-load.
- 2. Adjust for hypoid gear backlash and check for tooth contact.

10. Assemble Inter-Axle Differential and Through-Shaft Cage Assembly.

- A. Install the input forward radial bearing snap ring into cage.
- B. Press the input shaft oil seal into cage, from forward side, flush with snap ring.
- C. Press the forward radial bearing on input shaft with suitable sleeve bearing against inner race.
- D. Position the input shaft radial bearing into the cage bore flush with forward snap ring and install the rear radial bearing snap ring.

If input cage "O" ring has been scuffed or damaged in any way, replace with new.

- E. Install yoke or flange on splines and install washer, is used, and nut. Nut may be run up on threads only sufficient for handling assembly in chain falls and later tightened to correct torque when assembly is mounted into housing.

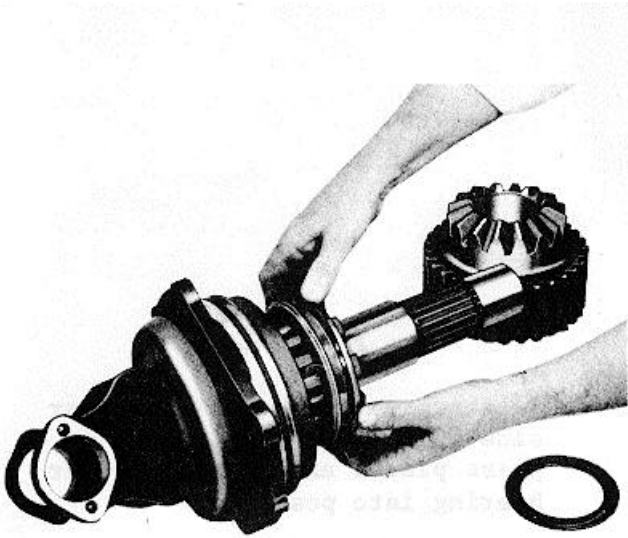

- F. Install the dog clutch collar on input shaft splines with the smooth side next to cage.

- G. Install the transfer gear thrust washer and transfer gear.
- H. Position the inter-axle differential forward case half over the forward side gear and assemble the spider pinions and thrust washers on spider.

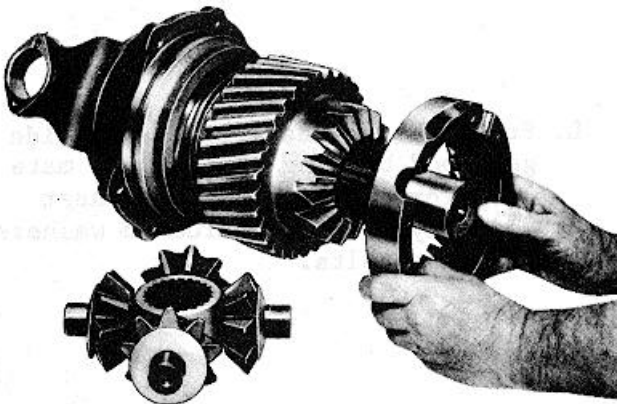

- I. Locate the assembly on input shaft splines. Turn the case half so that trunnion holes align with trunnions and slide assembly into case half.

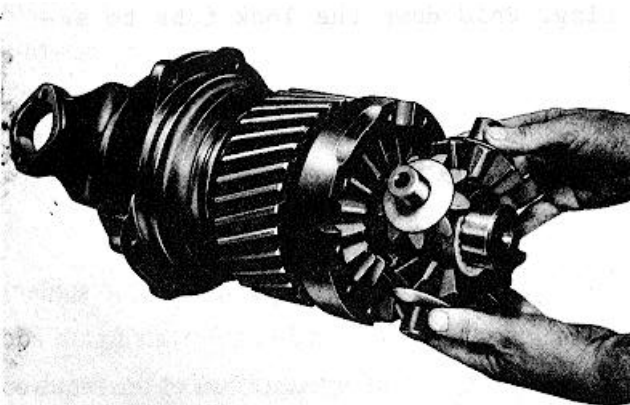

- J. Install the spider retainer and snap ring.

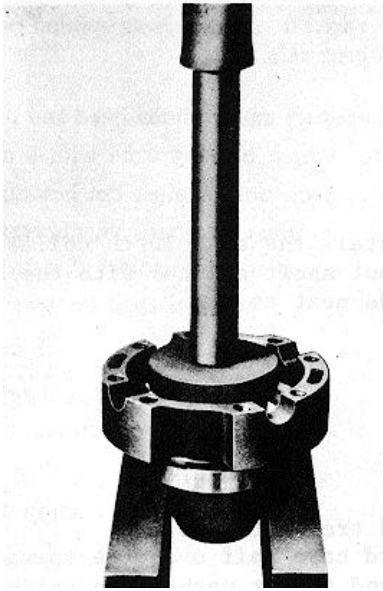

- K. Set the rear case half and rear side gear and thrust washer up on press plates and press the rear bearing into position.

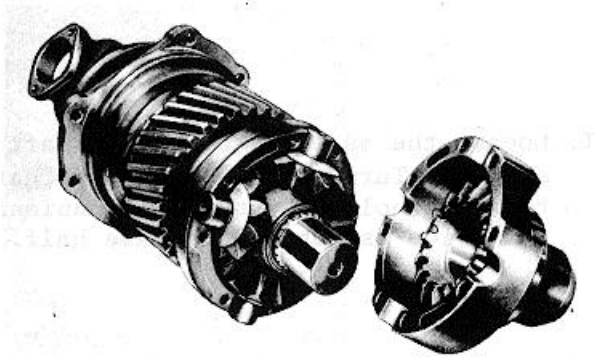

- L. Position the rear case half, side gear and bearing assembly to mate with forward case half and nest assembly. Install hardened washers and case bolts.

- M. Tighten the case bolt to specified torque and install lock wire.
- N. Install snap ring tab lock and snap ring. Fold down the lock tabs to secure snap ring.

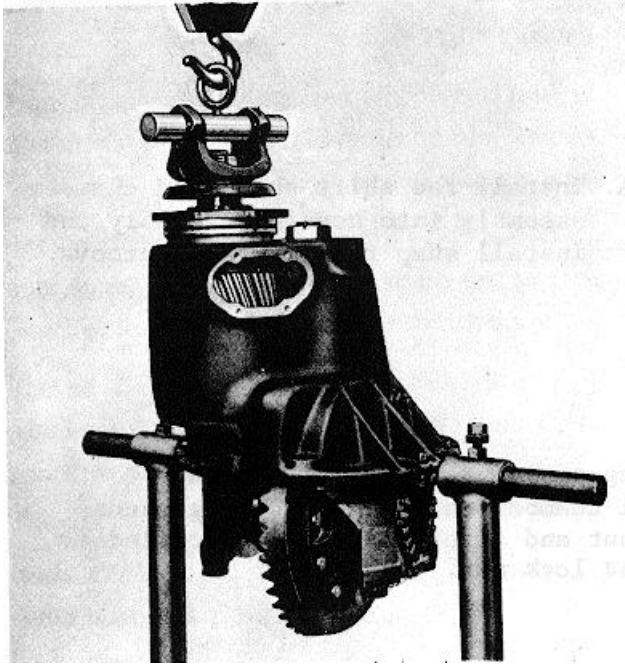

- O. Position the carrier housing with pinion and differential assembly upright in the carrier stand. By use of chain falls lower the inter-axle differential and input shaft assembly against a new gasket.

NOTE

PRODUCTION DRIVE GEARS AND DRIVEN GEARS ARE MATED AT TIME OF LAPPING. ONE DRIVE GEAR TOOTH IS MARKED WITH AN "X" AND ONE DRIVEN GEAR TOOTH SPACE IS MARKED WITH A CORRESPONDING SYMBOL (). WE SUGGEST THESE MATING MARKS BE LINED UP.

- P. Install the input cage lock washers and cap screws. Tighten cap screws to specified torque.
- Q. Tighten the input shaft or flange nut to specified torque and install cotter key.
- R. Tighten the pinion nut to specified torque and install cotter key.
- S. Position the pinion cover against a new gasket and install lock washers and cap screws. Tighten cap screws to specified torque.

11. Install Thrust Block.

- A. Remove carrier from stand and position with back face of hypoid or spiral bevel gear upward.
- B. Remove adjusting screw and lock nut.
- C. Place thrust block on rear face of hypoid gear and rotate gear until the hole in the thrust block is aligned with the adjusting screw hole.
- D. Install adjusting screw and lock nut and tighten adjusting screw sufficient to locate thrust block firmly against back face of hypoid gear.
- E. To secure the correct adjustment of .010"-.015" clearance, loosen adjusting nut 1/4 turn and lock securely with nut.
- F. Recheck to assure minimum clearance of .010" during full rotation of bevel gear.

12. Assemble and Install Shift Unit Housing and Diaphragm Assembly.

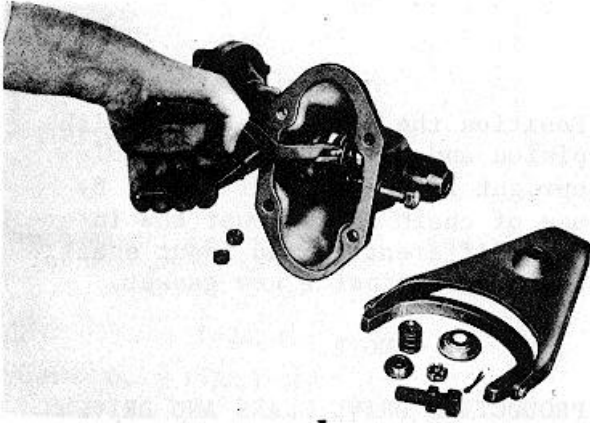

- A. Install the shift shaft and chamber assembly into housing assembly and install snap ring in shaft groove.

- B. Install next to snap ring the snap ring spring retainer and spring.
 C. Proceed with inserting the shaft until chamber mates with housing studs and gasket. Install lock washers and nut and tighten nuts to specified torque. Install the adjusting screw and lock nut.

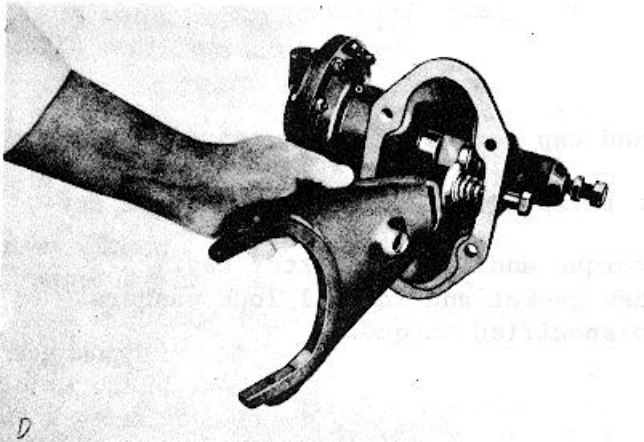

- D. Install on the body fit housing bolt the spring, cup and lever. Make sure lever end enters the shift shaft slot. Install the button and nut. Tighten nut securely with box wrench and cotter key.

- E. Position the shift and housing assembly into the carrier assembly against a new gasket, exercising care to properly locate the shifter yoke into clutch collar groove.

Lock-Out Engaged, Rear Adjusting Screw.

1. Back-off adjusting screw lock nut so screw is free-turning.
2. Shift assembly to engaged position with power chamber. Be sure shift collar is fully engaged with rear gear.
3. Turn-in screw until it is finger-tight against push rod.
4. Turn-in screw 1/2 revolution more to center fork in groove.
5. Tighten lock nut to specified torque.

13. Clean and Inspect Housing, Assemble Drive Unit.

- A. Remove any accumulation of dirt, grit or gum from housing bowl and sleeves. - Clean housing thoroughly with solvent and blow dry with compressed air.

- B. Inspect housing for cracks, loose studs, nicks, and burrs at machined surfaces. Remove nicks and burrs with stone or file. Make all necessary repairs or parts replacement before installing drive unit in housing.
- C. Install new drive unit to housing gasket over housing studs.

Roll carrier into position on roller jack. Start carrier into housing with four flat washers and nuts equally spaced.

Do not drive carrier into housing with a hammer at the carrier stud flange. The flange may easily be distorted and cause severe oil leakage.

Install lock washers and stud nuts on any studs under carrier housing offsets. It is impossible to start these nuts after carrier is drawn into housing.

- D. Tighten the four nuts over flat washers alternately to draw carrier squarely into axle housing.
- E. Remove nuts and flat washers. Install taper dowels, lock washers and stud nuts. Tighten to the correct torque.
- F. Connect universal at pinion shaft.
- G. Install axle shafts.

Preparation for Storage.

In the event the carrier is a spare and may not be immediately installed, all gears and bearings should be thoroughly oiled and the carrier placed in a dustproof container.

LUBRICATION.

Proper lubrication of the drive units is extremely important. Our "Standard" recommended lubricant is Rockwell-Standard Specification 0-65, S.A.E. 140 viscosity, multipurpose gear lubricant. Unusual operating conditions such as extremes in climatic temperatures may require lubricants of "Optional" viscosities. Refer to Field Maintenance Manual No. 1, "Lubrication," for detailed information.

Since Rockwell-Standard lubricant specifications are periodically revised, always refer to Field Maintenance Manual No. 1 for current complete lubricant specifications and applications.

New and Reconditioned Axle Service.

The original rear axle lubricant should be drained at the end of the drive-away or before the maximum of 3,000 miles prior to placing the vehicle in regular service. Drain the lubricant initially used in the assembly following reconditioning at the same interval. Completely drain the lubricant while the unit is warm.

Fill axle housings to bottom of level hole with specified lubricant with the vehicle level. Put an additional 2 U.S. pints of specified lubricant in the interaxle differential housing.

Regular Axle Service.

Refer to Field Maintenance Manual No. 1, "Lubrication", for recommended service interval. Service the inter-axle differential housing at the same time and in the same manner as the axle housings. Completely drain the lubricant while the unit is warm. Whenever the inter-axle differential housing has been drained, always add an additional 2 U.S. pints of specified lubricant directly to the interaxle differential housing.

Some newer model axles have a small tapped and plugged hole located near and below the housing lubricant level hole. This smaller hole has been provided for the use of a lubricant temperature indicator only and should not be used as a fill or level hole.

Jack up all four wheels of the assembly and run at 25 M.P.H. in high transmission gear for five minutes to thoroughly circulate the lubricant throughout the assembly. Be sure brakes are fully released.

TIRES.

Measure the rolling radii of all tires. The tires of all wheels must be matched to within 1/8" of the same rolling radius (3/4" of the same rolling circumference). The four largest tires should not be installed on one driving axle and the four smallest tires on the other driving axle of through drive type tandems. Such tire mounting will cause inter-axle "fight", unusually high axle lubricant temperatures that result in premature lubricant breakdown and possible costly axle service.

In addition to matching individual tire rolling radii or rolling circumference, we recommend matching, as nearly as possible, the total tire circumference of one driving axle to the total tire circumference of the other driving axle. This will usually result in satisfactory tandem axle lubricant temperatures that lengthen drive unit service with higher tire mileage.

How To Match Tandem Tires.

The vehicle should be on a level floor, carrying a correctly distributed rated capacity load. Be sure all tires are the same size. Measure new tires to be sure they will be correctly matched.

- A. Inflate all tires to the same pressure.
- B. Carefully measure the rolling circumference of each tire with a steel tape.
- C. Mark the size on each tire with chalk and arrange them in order of size, largest to smallest.
- D. Mount the two largest tires on one side of one axle and mount the two smallest on the opposite side of the same axle.
- E. Mount the four other tires on the other axle in the same manner.
- F. Test run the vehicle to get accurate rear axle lubricant temperature readings on the two axle lubricant temperature gauges.
- G. Vary tire air pressure within the tire manufacturer's recommended range, so the lubricant temperatures of both axles are within 30°F of each other and not in excess of 220°F. This will usually result in uniform tire loading and good tire life.

Refer to Field Maintenance Manual No. 11, "Tandem Hook-Ups", for additional information which applies to tandem assemblies.

PINION.

Pre-Load.

The lower driving shaft with the integrally machined pinion reduction gear is mounted on two tapered bearings. Pinion bearing pre-load is maintained and adjusted by the use of a hardened precision spacer mounted between the bearings (using the driven transfer gear as a spacer as well).

ADJUSTMENT.

The hypoid adjustment is made by increasing or decreasing shim or spacer thickness behind the inner bearing cup. This requires a corresponding change in the hardened cone spacer so as not to change the bearing pre-load.

GEAR.

Pre-Load.

The hypoid gear is riveted to one of the differential case halves. The cases are mounted between two tapered bearings in the carrier legs. Pre-load is adjusted and maintained with threaded adjusting rings.

ADJUSTMENT.

Backlash is corrected or adjusted by moving the gear only. This is done by backing off one adjusting ring and advancing the opposite ring the same amount.

Single-Reduction Drive Unit. (Illus. 4-46).

DISASSEMBLY.

1. Remove Differential Carrier from Housing.
 - A. Remove plug from bottom of axle housing and drain lubricant.
 - B. Remove the axle shaft stud nuts, lockwashers and tapered dowels.

NOTE

TO LOOSEN THE DOWELS, HOLD A 1 1/2 INCH DIAMETER BRASS DRIFT AGAINST THE CENTER OF THE AXLE SHAFT HEAD, INSIDE THE CIRCULAR DRIVING LUGS. STRIKE THE DRIFT A SHARP BLOW WITH A 5 TO 6 POUND HAMMER OR SLEDGE. A 1 1/2 INCH DIAMETER BRASS HAMMER IS AN EXCELLENT AND SAFE DRIFT.

CAUTION

DO NOT HIT THE CIRCULAR DRIVING LUGS ON THE SHAFT HEAD THIS MAY CAUSE THE LUGS TO SHATTER AND SPLINTER. DO NOT USE CHISELS OR WEDGES TO LOOSEN THE SHAFT OR DOWELS THIS WILL DAMAGE THE HUB, SHAFT AND OIL SEAL.

- C. Remove the axle shaft from the drive unit and housing.
- D. Disconnect universal at pinion shaft.
- E. Remove carrier to housing stud nuts and washers. Loosen two top nuts and leave on studs to prevent carrier from falling.
- F. Break carrier loose from axle housing with rawhide mallet.

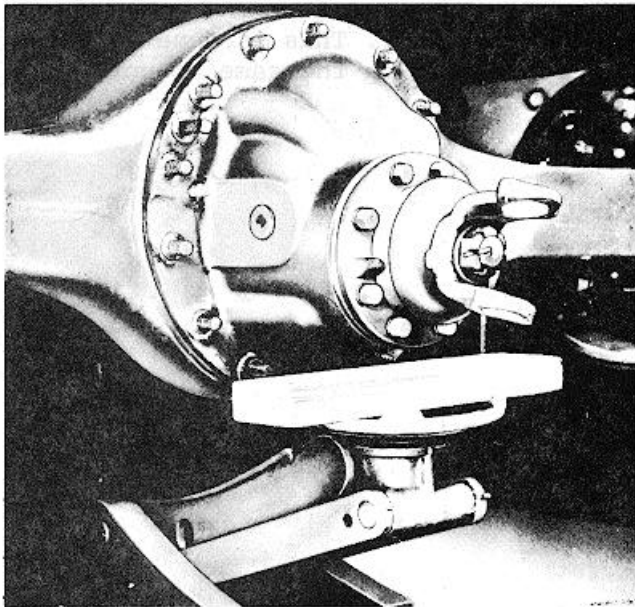

G. Remove top nuts and washers and work carrier free. A small pinch bar may be used to straighten the carrier in the housing bore. However, the end must be rounded to prevent indenting the carrier flange. A roller jack may be used to facilitate removal of carrier.

2. Disassemble Carrier.

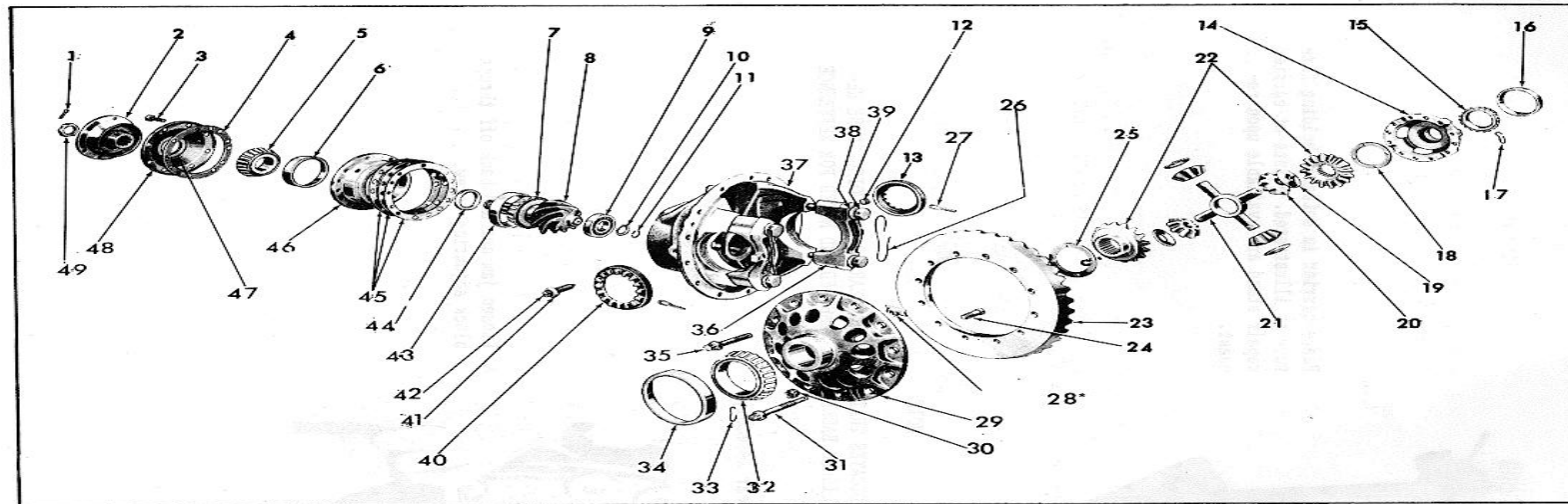

- | | | |
|---|-----------------------------------|--|
| 1. Cotter Key | 19. Diff. Pinion Thrust Washer | 37. Diff. Carrier and Cap Assembly |
| 2. Drive Pinion Flange and Slinger Assembly | 20. Diff. Pinion | 38. Hardened Washer |
| 3. Capscrew | 21. Diff. Spider | 39. Diff. Bearing Cap Capscrew |
| 4. Gasket | 22. Diff Side Gear | 40. Diff. Bearing Adjusting Nut |
| 5. Drive Pinion Outer Bearing | 23. Drive Gear | 41. Thrust Block Adjusting Screw Jam Nut |
| 6. Drive Pinion Outer Bearing Cup | 24. Gear to Case Bolt | 42. Thrust Block Adjusting Screw |
| 7. Drive Pinion Inner Bearing | 25. Diff. Side Gear Thrust Washer | 43. Drive Pinion Inner Bearing Cup |
| 8. Drive Pinion | 26. Lockwire | 44. Drive Pinion Bearing Spacer |
| 9. Drive Pinion Pilot Bearing | 27. Cotter Key | 45. Shims |
| 10. Pilot Bearing Washer | 28. Thrust Block | 46. Drive Pinion Bearing Cage |
| 11. Pilot Bearing Snap Ring | 29. Dill. Case Flange Hall | 47. Pinion Cage Cover Oil Seal |
| 12. Oil Filler Plug | 30. Gear to Case Bolt Nut | 48. Pinion Cage Cover |
| 13. Diff. Bearing Adjusting Nut Lock | 31. Dill. Case Bolt (Long) | 49. Drive Pinion Nut |
| 14. Diff. Case Hall | 32. Diff. Bearing | |
| 15. Diff. Bearing | 33. Lockwire | |
| 16. Diff. Bearing Cup | 34. Diff. Bearing Cup | |
| 17. Lockwire | 35. Diff. Case Bolt | |
| 18. Diff. Side Gear Thrust Washer | 36. Diff. Bearing Cap | |

Some Models may employ only the thrust screw which may replace the thrust screw and block assembly.

Illustration 4-46. Single-Reduction Drive Unit.

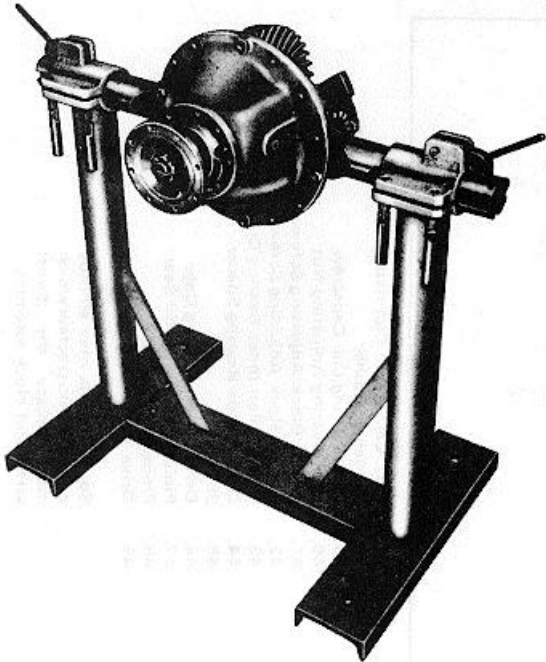

Place carrier in suitable holding fixture as illustrated. Prints of carrier repair stand are available upon request.

NOTE

IF THE INITIAL INSPECTION INDICATES THAT THE DRIVE GEAR IS NOT GOING TO BE REPLACED, WE SUGGEST THE ESTABLISHED BACKLASH BE MEASURED AND NOTED FOR REFERENCE AND USED AT REASSEMBLY.

3. Remove Differential and Gear Assembly.

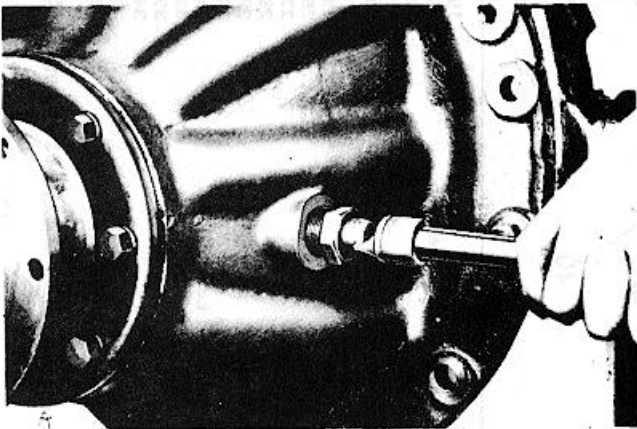

- A. Loosen Jam nut and back off thrust block adjusting screw.

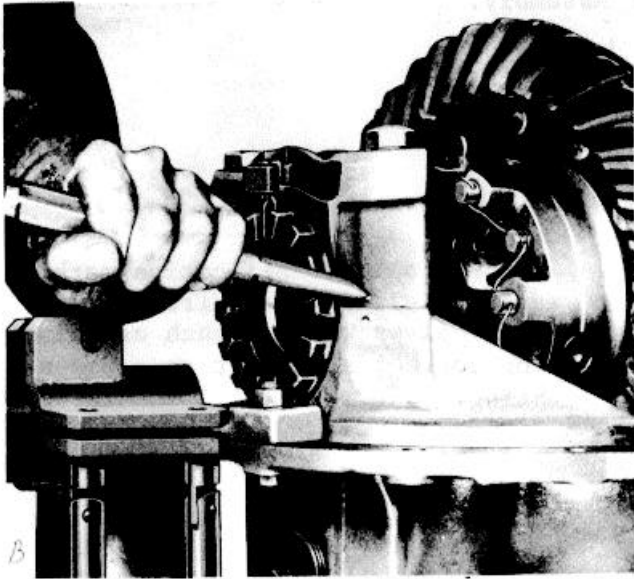

- B. Center punch one differential carrier leg and bearing cap to identify for properly reassembling.

- C. Cut lock wire, if used. Removed cap screws and adjusting nut locks.
- D. Remove bearing cap stud nuts or cap screws, bearing caps and adjusting nuts.

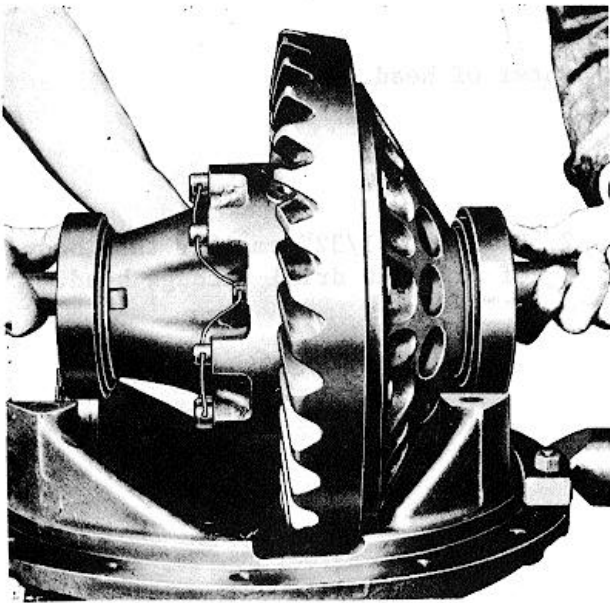

- E. Lift out differential and gear assembly.

- F. Remove thrust block, if used, from inside of carrier housing.

4. Disassemble Differential Case and Gear Assembly.

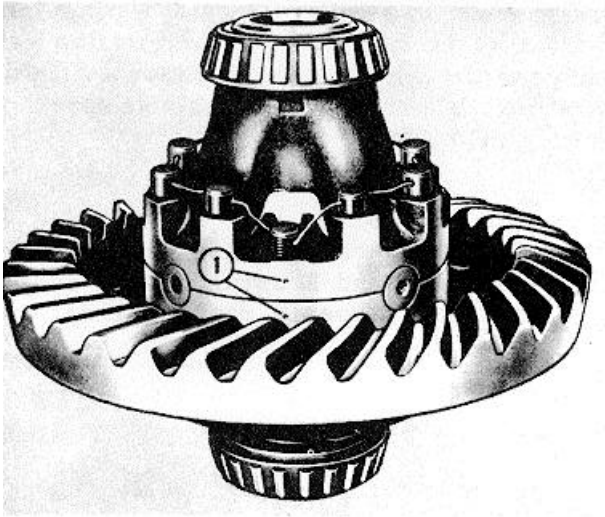

- A. If original identification marks are not clear, mark differential case halves with a punch or chisel for correct alignment on reassembling.

- B. Cut lock wire, if used, remove bolts and separate case halves.
- C. Remove spider, pinions, side gears and thrust washers.
- D. If necessary, remove rivets and separate gear and case.

REMOVE GEAR RIVETS.

- 1. Carefully center punch rivets in center of head.

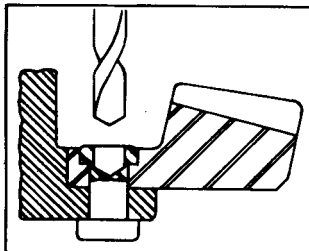

RIGHT

- 2. Use drill 1/32" smaller than body of rivet to drill through head.

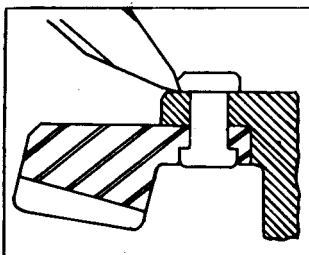

WRONG

- 3. Press out rivets.

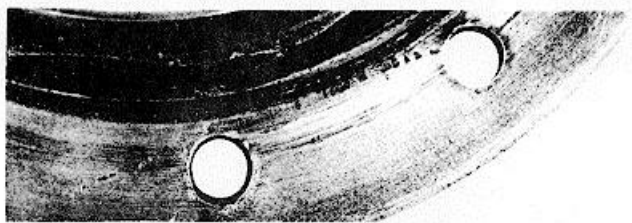

SHOWING HOW HOLES IN FLANGE WERE ELONGATED WHEN RIVETS WERE CHISELED OUT.

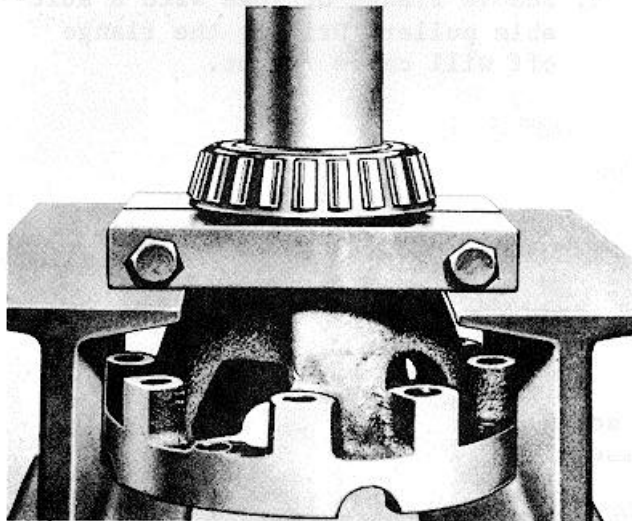

- E. If necessary to replace differential bearings, remove with a suitable puller.

5. Remove Pinion and Cage Assembly.

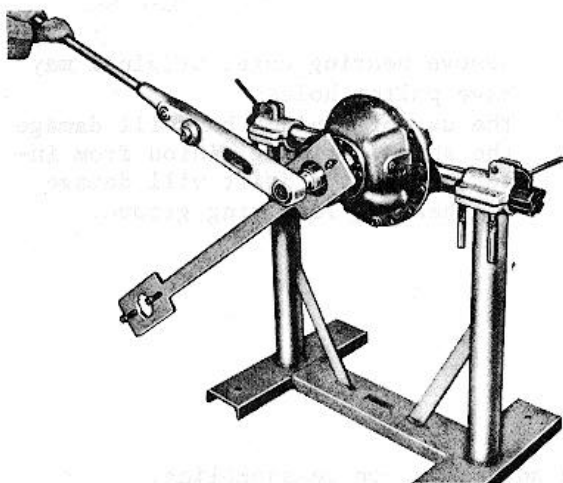

- A. Hold flange or yoke with suitable tool and remove pinion shaft nut and washer.

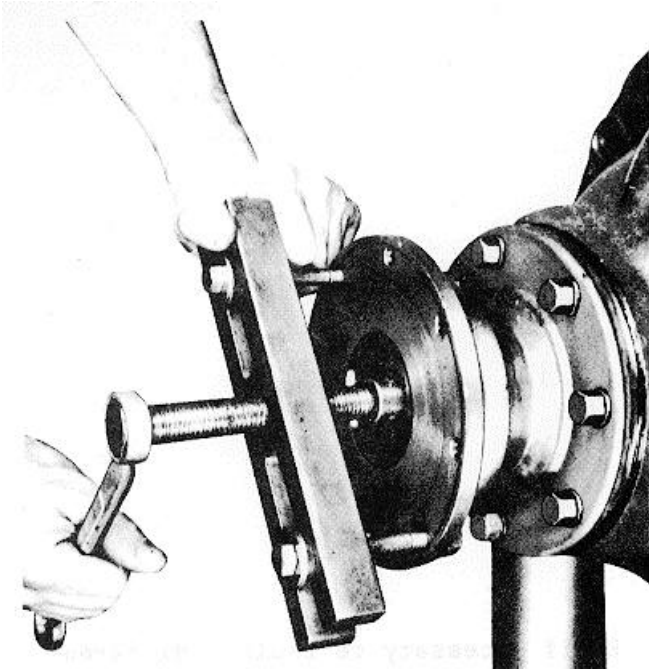

- B. Remove flange or yoke with a suitable puller. Driving the flange off will cause runout.

- C. Remove pinion cage stud nuts or cap screws.
- D. Remove bearing cover and oil seal assembly.

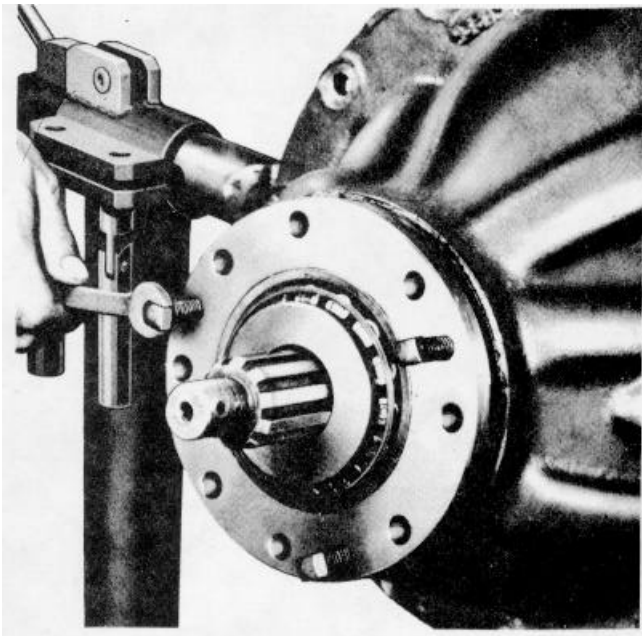

- E. Remove bearing cage. Original may have puller holes. The use of a pinch bar will damage the shims. Driving pinion from inner end with a drift will damage the bearing lock ring groove.

- F. Wire shim pack together to facilitate adjustment on reassembling.

6. Disassemble Pinion and Cage Assembly.

NOTE

BOTH SPLINED AND TAPERED PINION SHAFTS ARE USED IN SINGLE REDUCTION CARRIERS. WHERE THE TAPERED SHAFT IS USED, THE THRUST BEARINGS ARE ADJUSTED BY MEANS OF ADJUSTING SCREWS AND LOCK NUTS OR THRUST SCREWS. ON THE SPLINED SHAFT THIS ADJUSTMENT IS SECURED WITH A SELECTIVE SPACER OR SPACER COMBINATION.

Splined Shaft.

- A. Tap shaft out of cage with soft mallet or press shaft from cage.
- B. Remove outer bearing from cage.
- C. Remove spacer or spacer combination from pinion shaft.

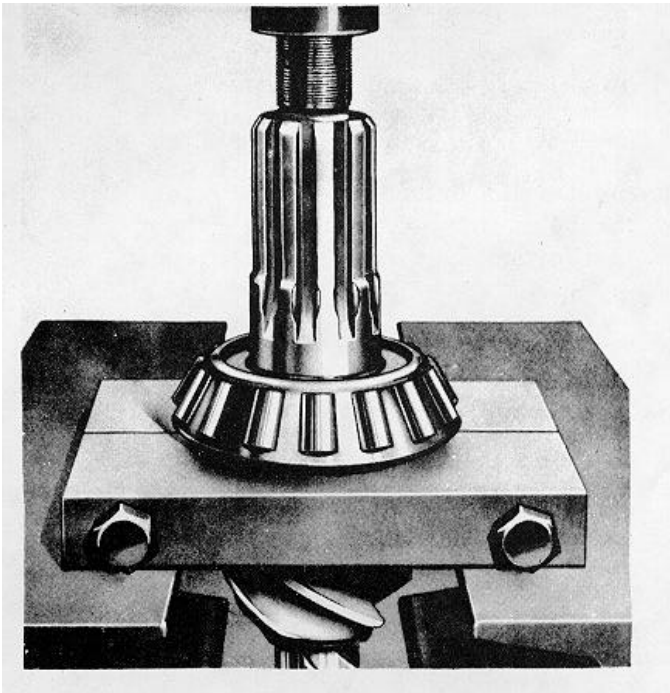

- D. If necessary to replace rear thrust bearing or radial bearing, remove with suitable puller.

- E. Remove oil seal assembly from bearing cover.

Tapered Shaft.

- A. Straighten lock washer and remove lock nut, washer, adjusting nut and thrust washer.
- B. Tap pinion out of cage with soft mallet or press shaft from cage.
- C. Remove bearing from cage.
- D. Remove bearings from shaft with suitable puller if necessary.
- E. Remove oil seal assembly from bearing cover.

Clean, Inspect and Repair.

Parts having ground and polished surfaces such as gears, bearings, shafts and collars, should be cleaned in a suitable solvent such as kerosene or diesel fuel oil.

CAUTION

GASOLINE SHOULD BE AVOIDED. DO NOT CLEAN THESE PARTS IN A HOT SOLUTION TANK OR WITH WATER AND ALKALINE SOLUTIONS SUCH AS SODIUM HYDROXIDE, ORTHOSILICATES OR PHOSPHATES.

Do not recommend steam cleaning assembled drive units after they have been removed from the housing. When this method of cleaning is used, water is trapped in the cored passage of the castings and in the close clearances between parts as well as on the parts. This can lead to corrosion (rust) of critical parts of the assembly and the possibility of circulating rust particles in the lubricant. Premature failure of bearings, gears and other parts can be caused by this practice. Assembled drive units cannot be properly cleaned by steam cleaning, dipping or slushing. Complete drive unit disassembly is a necessary requisite to thorough cleaning.

Rough Parts.

Rough parts such as differential carrier castings, cast brackets and some brake parts may be cleaned in hot solution tanks with mild alkali solutions providing these parts are not ground or polished. The parts should remain in the tank long enough to be thoroughly cleaned and heated through. This will aid the evaporation of the rinse water. The parts should be thoroughly rinsed after cleaning to remove all traces of alkali.

CAUTION

EXERCISE CARE TO AVOID SKIN RASHES AND INHALATION OF VAPORS WHEN USING ALKALI CLEANERS.

Complete Assemblies.

Completely assembled axles, torque dividers and transfer cases may be steam cleaned on the outside only, to facilitate initial removal and disassembly, providing all openings are closed. Breathers, vented shift units, and all other openings should be tightly covered or closed to prevent the possibility of water entering the assembly.

Drying.

Parts should be thoroughly dried immediately after cleaning. Use soft, clean, lintless absorbent paper towels or wiping rags free of abrasive material, such as lapping compound, metal filings or contaminated oil. Bearings should never be dried by spinning with compressed air.

Corrosion Prevention.

Parts that have been cleaned, dried, inspected and are to be immediately reassembled should be coated with light oil to prevent corrosion. If these parts are to be stored for any length of time, they should be treated with a good RUST PREVENTIVE and wrapped in special paper or other material designed to prevent corrosion.

INSPECT.

It is impossible to overstress the importance of careful and thorough inspection of drive unit parts prior to reassembly. Thorough visual inspection for indications of wear or stress, and the replacement of such parts as are necessary will eliminate costly and avoidable drive unit failure.

- A. Inspect all bearings, cups and cones, including those not removed from parts of the drive unit, and replace if rollers or cups are worn, pitted or damaged in any way. Remove parts needing replacement with a suitable puller or in a press with sleeves. Avoid the use of drifts and hammers. They may easily mutilate or distort component parts.
- B. Inspect hypoid gears for wear or damage. Gears which are worn, ridged, pitted or scored, should be replaced. When necessary to replace either the pinion or gear of hypoid set, the entire gear set should be replaced.
- C. Inspect the differential assembly for the following:
 - 1. Pitted, scored or worn thrust surfaces of differential case halves, thrust washers, spider trunnions and differential gears. Thrust washers must be replaced in sets. The use of a combination of old and new washers will result in premature failure.
 - 2. Wear or damage to the differential pinion and side gear teeth. Always replace differential pinions and side gears in sets.
- D. Inspect axle shafts for signs of torsional fractures or other indication of impending failure.

REPAIR.

- A. In the interest of safety and preserving the service life of drive axle assemblies, Rockwell-Standard recommends that drive axle assemblies not be repair welded. Repair welding can detract from the structural integrity of a component, particularly as to heat treated parts where the benefit of heat treatment may be nullified by the welding.

Since it can be extremely hazardous and detrimental to repair weld components of any kind, repair welding can be approved only where stringent controls are imposed and equipment, customarily located only at manufacturing facilities, is employed, so as to minimize the potentially detrimental effects of repair welding.

In deciding whether to repair or scrap any damaged part, always keep in mind that we, as manufacturers, never hesitate to scrap any part which is in any way doubtful.

- B. Hex nuts with rounded corners, all lock washers, oil seals and gaskets should be replaced at the time of overhaul.

Use only genuine Rockwell-Standard replacement parts for satisfactory service. For example, using gaskets of foreign material generally leads to mechanical trouble due to variations in thickness and the inability of certain materials to withstand compression, oil, etc.

- C. Remove nicks, mars and burrs from machined or ground surfaces. Threads must be clean and free to obtain accurate adjustment and correct torque. A fine mill file or India stone is suitable for this purpose. Studs must be tight prior to reassembling the parts.

- D. All Rockwell-Standard bronze bushed differential pinions should be ball burnished after bushing installation. Install the bushing with a small stepped drift. The small O.D. should be .010" smaller than the bushing burnished I.D. and 1 1/2 times bushing length. Always install bushings so end is even with the I.D. chamfer or about 1/16" below the spherical surface.
- E. When assembling component parts use a press where possible.
- F. Tighten all the nuts to the specified torque. (See torque limits following service instructions). Where a lock-wire is employed, use soft iron locking wire to prevent possibility of wire breakage.
- G. The burrs, caused by lock washers, at the spot face of stud holes of cages and covers should be removed to assure easy reassembly of these parts.

REASSEMBLY. (Table 4-2).

- 1. Reassemble Pinion and Cage Assembly.

Splined Shaft.

- A. If new cups are to be installed, press firmly against pinion bearing cage shoulders.
- B. Lubricate bearings and cups with light machine oil.

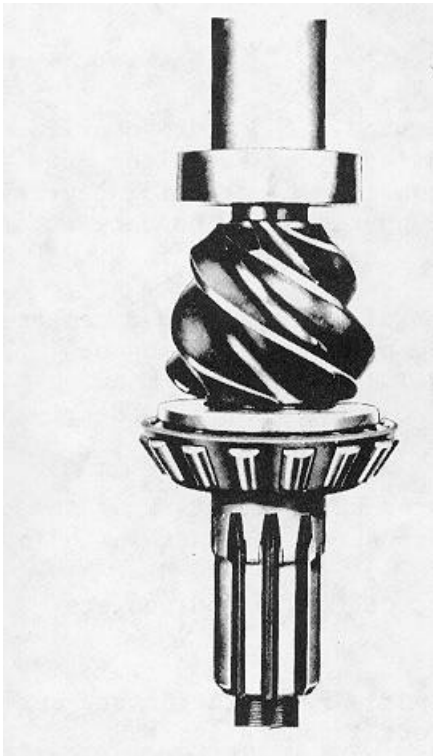

- C. Press rear thrust and radial bearings firmly against the pinion shoulders with a suitable sleeve that will bear only on bearing inner race.

- D. Install radial bearing lock ring and squeeze ring into pinion shaft groove with pliers.
- E. Insert pinion and bearing assembly in pinion cage and position spacer or spacer combination over pinion shaft.
- F. Press front bearing firmly against spacer.

TABLE 4-2 . SINGLE - REDUCTION DRIVE UNIT TORQUE LIMITS





<u>NOMENCLATURE</u>	<u>BOLT SIZE</u>		<u>TORQUE LB.FT.</u>
Pinion Bearing Cage To Carrier Capscrews	3/8"-16		30-40
	7/16"-14		50-65
	1/2"-13		80-105
	5/8"-11		130-170
Oil Filler Plug			Thread into Carrier Housing to Allow One Thread Stand Out
Adjusting Ring Lock (Some Models Only)			
Adjusting Ring Lock to Diff. Bearing Cap Capscrews	5/16"-18		15-20
	5/16"-18		22-28
Diff. Case Capscrews or Bolts and Nuts (Long & Short)	3/8"-16		35-50
	7/16"-14		60-75
	1/2"-13		90-120
	1/2"-20		105-135
	5/8"-11		185-235
	5/8"-18		210-270
	3/8"-16		35-50
	7/16"-14		60-75
	1/2"-13		90-120
	1/2"-20		105-135
	5/8"-11		185-235
5/8"-18		210-270	
Gear to Diff. Case Bolts Nuts	5/8"-18		210-270
	1/2"-20 L		105-135
	5/8"-11		150-190
	1/2"-13		90-120
Diff. Case Bolt With Nut 'Thru Bolt' Type (Some Models Only)			
Diff. Bearing Cap to Carrier Capscrews	9/16"-12		116-129
	5/8"-11		160-180
	3/4"-10		290-320
	7/8"-14		375-415
	7/8"-9		1470-520

TABLE 4-2. SINGLE - REDUCTION DRIVE UNIT TORQUE LIMITS (continued)

<u>NOMENCLATURE</u>	<u>BOLT SIZE</u>	<u>TORQUE LB.FT.</u>
	9/16"-12	115-140
	5/8"-11	160-190
	3/4"-10	290-350 4
	7/8"-14	375-435
	7/8"-9	470-550
Thrust Screw Jam Nut	3/4"-16	145-190
	7/8"-14	145-190
Pinion Shaft (Input) Nuts	7/8"-20	175-250
	7/8"-20 (Elastic Stop Nut)	200-275
	1" -20	300-400
	1 1/4"-18	700-900
	1 1/2"-18	800-1100
	1 3/4"-12	800-1100
	7/8"-20	200-275
	1" -20	300-400
	1 1/4"-18	700-900
	1 1/2"-18	800-1100
	1 3/4"-12	900-1200
	2" -12	1000-1300



NOTES

FOR ALL FASTENERS

ALL TORQUES GIVEN APPLY TO PARTS COATED WITH MACHINE OIL.

FOR DRY PARTS - INCREASE TORQUES 10%.

FOR PARTS COATED WITH MULTI-PURPOSE.

GEAR OIL - DECREASE TORQUE 10%.

NUTS ON STUDS TO USE THE SAME TORQUE AS FOR DRIVING THE STUD.



INDICATES TORQUE VALUES FOR FASTENERS USING LOCKWIRE OR COTTER PINS.

ALL OTHER TORQUE VALUES ARE FOR FASTENERS NOT USING LOCKWIRE OR COTTER PINS.

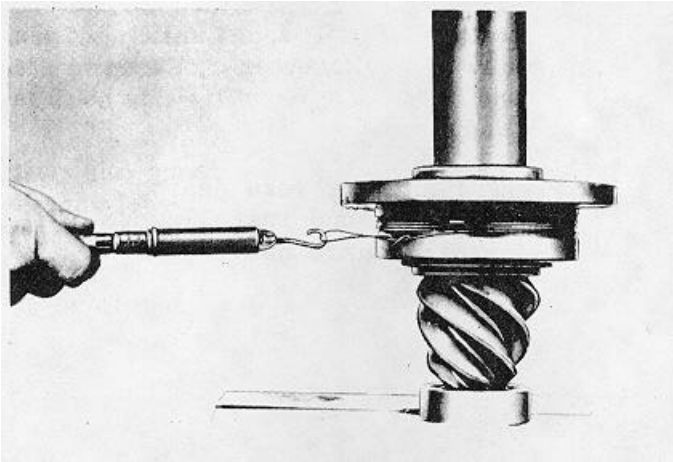

H. While in press under pressure, check bearing preload torque. Wrap soft wire around cage and pull on horizontal line with pound scale. If a press is not available, the pinion nut may be tightened to the correct torque and preload checked.

The correct pressures and torque for checking pressure bearing preload are as follows:

PINION SHAFT THREAD SIZE	PRESSURE REQUIRED TO OBTAIN CORRECT PRE-LOAD	NUT TORQUE REQUIRED (FOR FASTENERS USING LOCKWIRE OR COTTER PINS) TO OBTAIN CORRECT PRE-LOAD	NUT TORQUE REQUIRED (FOR FASTENERS NOT USING LOCKWIRE OR COTTER PINS) TO OBTAIN CORRECT PRE-LOAD
7/8"-20	6 tons	175- 200 lb. ft.	200- 275 lb. ft.
7/8"-20	6 tons (elastic stop nut)	200- 275 lb. ft.	-----
1" -20	6 tons	300- 400 lb. ft.	300- 400 lb. ft.
1 1/4"-18	11 tons	700- 900 lb. ft.	700- 900 lb. ft.
1 1/2"-12	14 tons	800-1100 lb. ft.	
1 1/2"-18	14 tons	800-1100 lb. ft.	800-1100 lb. ft.
1 3/4"-12	14 tons	800-1100 lb. ft.	900-1200 lb. ft.
2" -12	14 tons		1000-1300 lb. ft.

Use rotating torque, not starting torque.

If rotating torque is not within 5 to 15 pound inches, use thinner spacer to increase or thicker spacer to decrease preload.

NOTE

ASSUMING PINION CAGE DIAMETER TO BE 6 INCHES, THE RADIUS WOULD BE 3 INCHES AND WITH 5 POUNDS PULL WOULD EQUAL 15 POUND INCHES PRELOAD TORQUE.

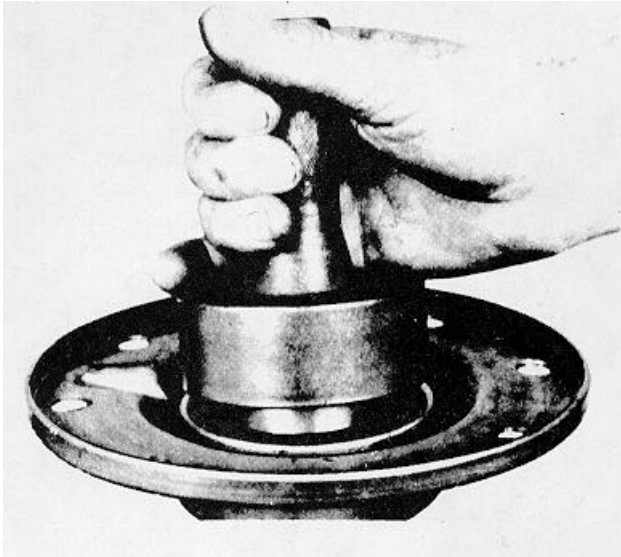

- I. Press flange or yoke against forward bearing and install washer and pinion shaft nut.

- J. Place pinion and cage assembly over carrier studs, hold flange and tighten pinion shaft nut to the correct torque. The flange must be held with a suitable tool or fixture to tighten nut.

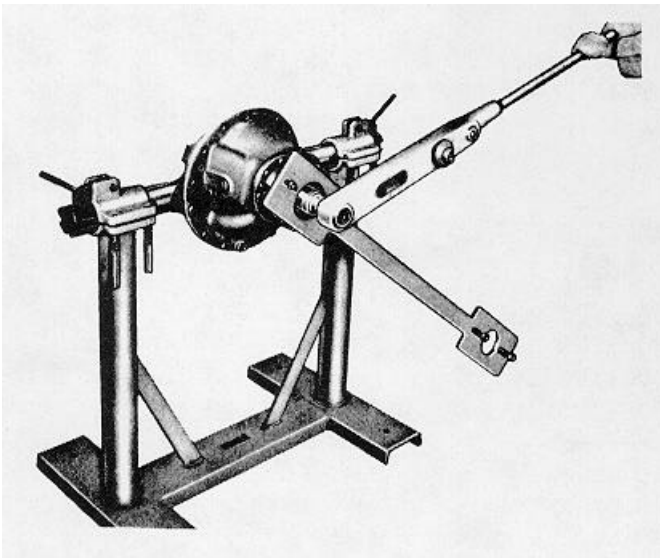

- K. Recheck pinion bearing preload torque. If rotating torque is not within 5 to 15 pound inches, repeat the foregoing procedure.

- L. Hold flange and remove pinion shaft nut and flange.
- M. Lubricate pinion shaft oil seal and cover outer edge of seal body with a non-hardening sealing compound. Press seal against cover shoulder with seal driver.

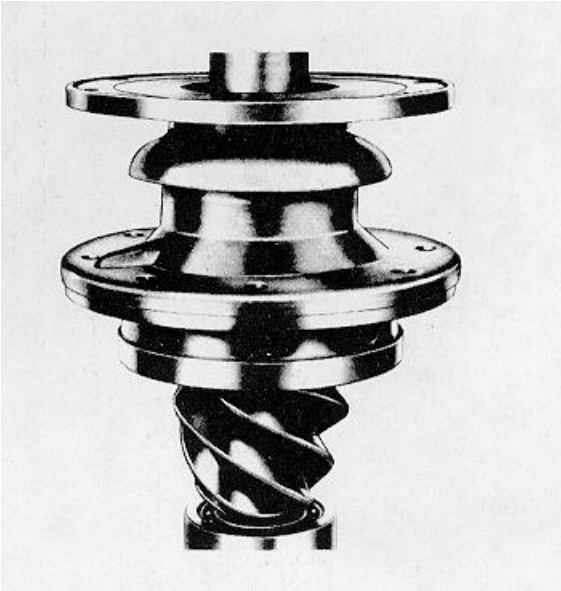

N. Install new gasket and bearing cover.

- O. Press flange against forward bearing and install washer and pinion shaft nut.
- P. Tighten to the correct torque. If a drilled or castellated fastener is employed install a cotter key. Do not back off nut to align cotter key holes.

Tapered Shaft.

- A. Press rear thrust and radial bearings firmly against the pinion shaft shoulder.
- B. Install radial bearing lock ring and squeeze ring into pinion shaft groove with pliers.
- C. If new cups are to be installed, press firmly against pinion cage shoulders.
- D. Lubricate bearings and cups with light machine oil.
- E. Install forward bearing, thrust washer and adjusting nut.
- F. Install new lock washer and the lock nut.
- G. Adjust pinion bearing preload to 5 to 15 pound inches with lock nut tightened securely against washer. The lock nut must be tight to secure the correct preload.
- H. Bend lock washer when correct adjustment has been secured.
- I. Lubricate pinion shaft oil seal and cover outer edge of seal body with a non-hardening sealing compound. Press seal against cover shoulder with seal driver.
- L. Install new gasket and bearing cover. Cover should be carefully installed to prevent cutting seal on keyway.
- K. Install key, press flange on taper and install washer and pinion shaft nut.
- L. Tighten to the correct torque. If a drilled or castellated fastener is employed install a cotter key.
Do not back off nut to align cotter key holes.

2. Install Pinion and Cage Assembly.

- A. Install correct shim pack. Locate thin shims on both sides for maximum sealing ability.
- B. Position pinion and cage assembly over studs and tap into position with soft mallet.

C. Install lock washers and stud nuts or cap screws. Tighten to the correct torque.

3. Assemble Differential and Gear.

A. Rivet the hypoid gear to the case half with new Rockwell-Standard rivets. Rivets should not be heated, but always upset cold. When the correct rivet is used, the head being formed will be at least 1/81 larger in diameter than the rivet hole. The head will then be approximately the same height as the preformed head. Excessive pressure will cause distortion of the case holes and result in gear eccentricity. Tonnage required for squeezing cold rivets. These pressures are approximate for annealed steel rivets and pressure can be adjusted to suit individual working conditions.

DIAMETER OF RIVET	TONNAGE REQUIRED	
7/16"	22	
1/2"		30
9/16"	36	
5/8"		45

Final pressure should be held for approximately one minute to make sure the rivet has filled the hole.

Differential case and gear bolts are available for service replacement of rivets. The use of bolts greatly facilitates servicing these units in the field and eliminates the need for special equipment necessary to correctly cold upset rivets. Consult chart for service bolt instruction shown with the torque chart on last page of manual.

B. Lubricate differential case inner walls and all component parts with axle lubricant.

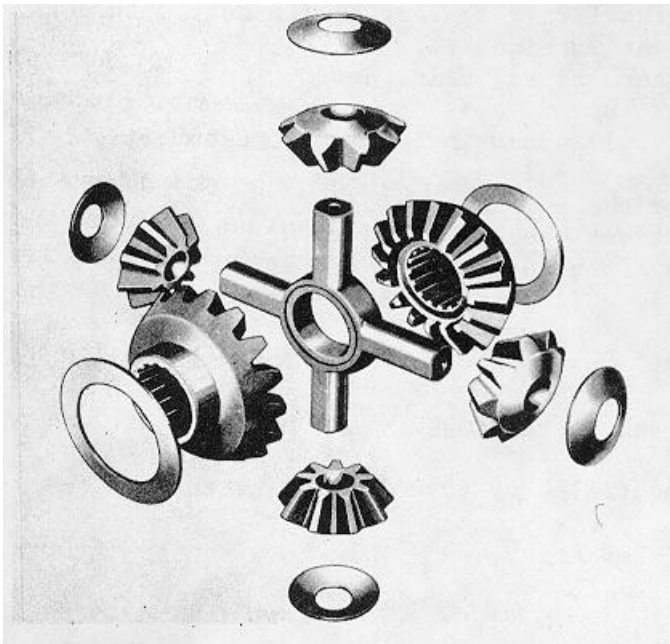

DIFFERENTIAL PINION AND SIDE GEAR ASSEMBLY

- C. Position thrust washer and side gear in bevel gear and case half assembly.
- D. Place spider with pinions and thrust washers in position.
- E. Install component side gear and thrust washer.

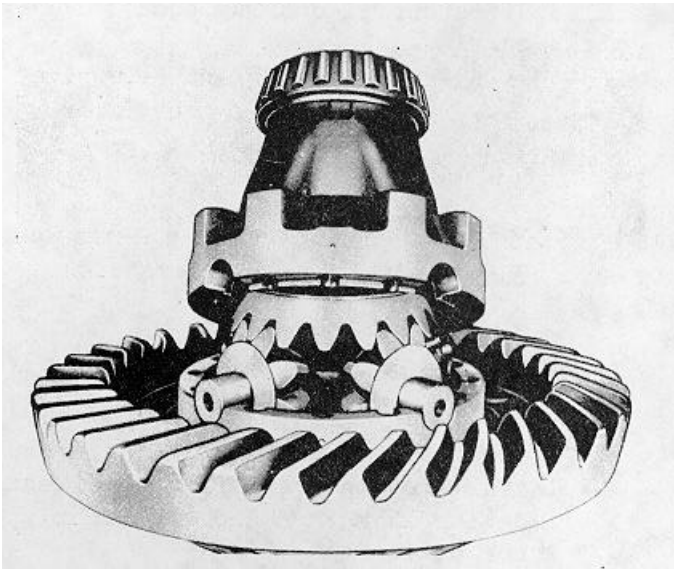

- F. Align mating marks, position component case half and draw assembly together with four bolts or cap screws equally spaced.

- G. Check assembly for free rotation of differential gears and correct if necessary.
- H. Install remaining bolts and cap screws, tighten to the correct torque. If a drilled or castellated fastener is employed, install a lockwire.
- I. If bearings are to be replaced, press squarely and firmly on differential case halves.

4. Install Bearing Cups in Carrier Leg Bores.

- A. Temporarily install the bearing cups, threaded adjusting rings where employed and bearing caps. Tighten the cap screws to the proper torque.

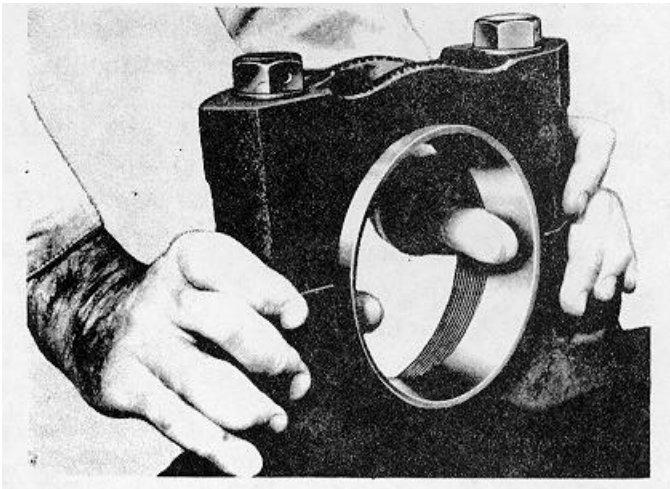

- B. The bearing cups must be of a hand push fit in the bores, otherwise the bores must be reworked with a scraper or some emery cloth until a hand push fit is obtained. Use a blued bearing cup as a gauge and check the fits as work progresses. Once the cups fit properly, remove the bearing caps.

B.

5. Install Differential and Gear Assembly.

- A. After checking related parts, coat the differential bearing cones and cups with specified rear axle lubricant.
- B. Place the bearing cups over the assembled differential bearing cones, then position the differential assembly in the carrier
- C. Insert bearing adjusting nuts and turn handtight against bearing cups.

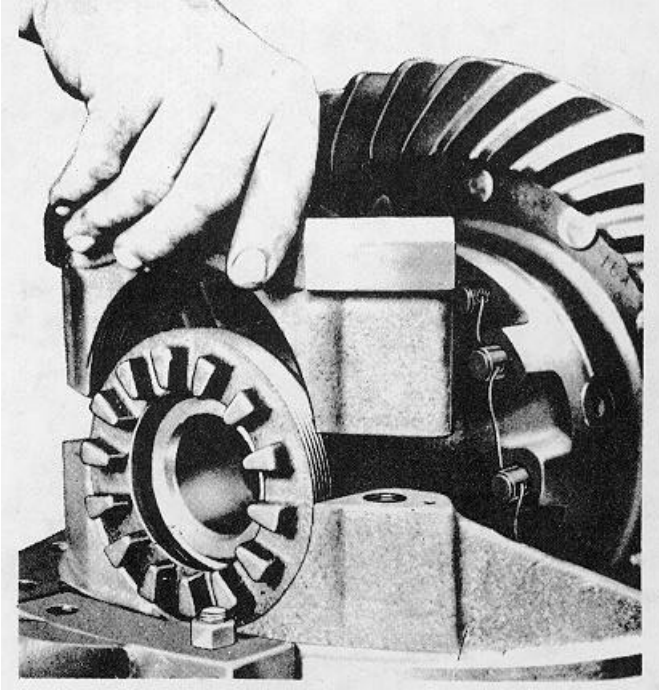

- D. Install bearing caps in the correct location as marked and tap lightly into position.

- E. Install flat washers where used and stud nuts or cap screws. Tighten stud nuts or cap screws to correct torque. If carrier leg fasteners are drilled or castellated, lockwire after final adjustments are made.

NOTE

IF BEARING CAPS DO NOT POSITION PROPERLY, ADJUSTING NUTS MAY BE CROSS THREADED. REMOVE CAPS AND REPOSITION THE ADJUSTING NUTS. FORCING CAPS INTO POSITION WILL RESULT IN IRREPARABLE DAMAGE TO THE CARRIER HOUSING OR BEARING CAPS.

6. Adjust Differential Bearing Preload.

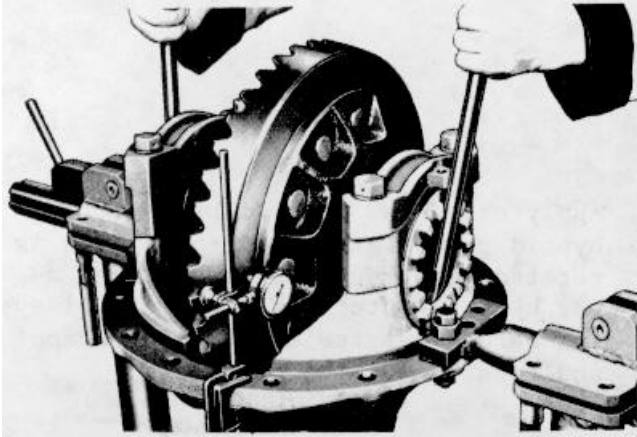

- A. Using dial indicator at backface of gear, loosen the bearing adjusting nut on the side opposite gear only sufficient to notice end play on the indicator

- B. Tighten the same adjusting nut only sufficient to obtain .00 end play.
- C. Check gear for runout. If runout exceeds .008", remove differential and check for cause.
- D. Tighten adjusting nuts one notch each from .000 end play to preload differential bearings.

7. Check Hypoid Gear Backlash.

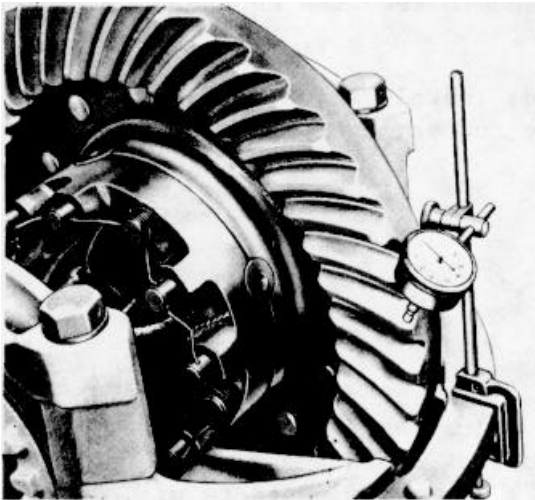

If the drive gear is not going to be replaced, we suggest the established backlash recorded before disassembly be used. For new gears the new backlash should be initially set at .010". Adjust backlash by moving the gear only. This is done by backing off one adjusting ring and advancing the opposite ring the same amount.

CHECK TOOTH CONTACT.



Apply oiled red lead lightly to the hypoid gear teeth. When the pinion is rotated, the red lead is squeezed away by the contact of the teeth, leaving bare areas the exact size, shape and location of the contacts.

Sharper impressions may be obtained by applying a small amount of resistance to the gear with a flat steel bar and using a wrench to rotate the pinion. When adjustments, check the drive side of the gear teeth. Coast side should be automatically correct when drive side is correct. As a rule, coating about twelve teeth is sufficient for checking purposes.

After obtaining a satisfactory tooth contact, especially in relation to the top and bottom of the tooth, the backlash can be altered within the limits of .005"-.015" to obtain a better contact position relative to the length of the tooth.

A high backlash setting can be used to keep the contact from starting too close to the toe, and a low backlash setting can be used to keep the contact from starting too far away from the toe.

After correct tooth contact has been established, install adjusting nuts locks and cap screws. Tighten cap screws and lock wire to bearing capscrews.

CORRECT TOOTH CONTACT ASSURES LONGER GEAR LIFE.

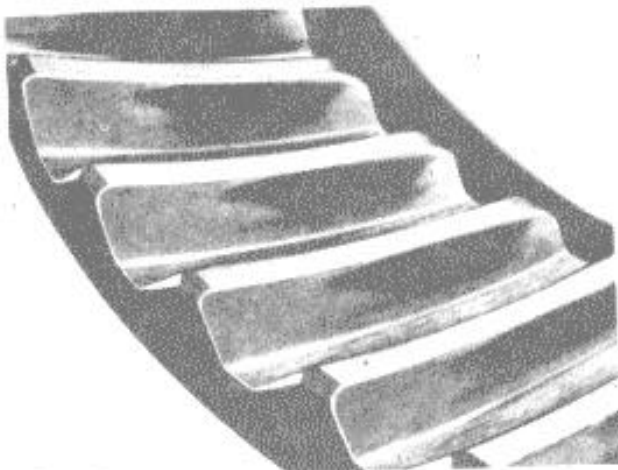

SATISFACTORY TOOTH CONTACT
(GEARS UNLOADED)

With adjustments properly made (pinion at correct depth and backlash set at .010") the above contacts will be procured. The area of contact favors the toe and is centered between the top and bottom of the tooth.

The hand rolled pattern shown (gears unloaded), will result in a pattern centered in the length of the tooth when the gears are under load shown below. The loaded pattern will be almost full length and the top of pattern will approach the top of the gear tooth.

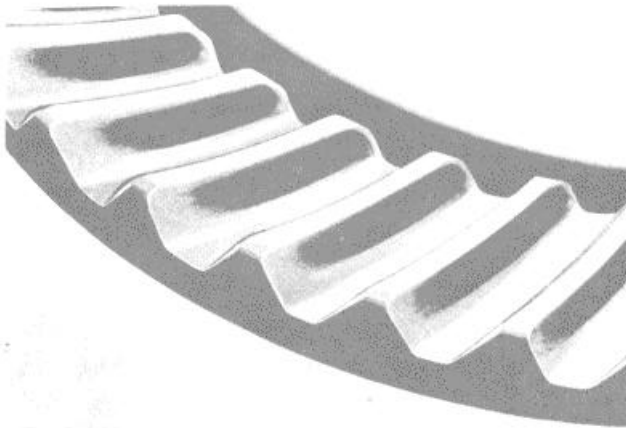

The pattern on the coast side of teeth will appear the same width-as the drive side shown; however, the overall length will be centered between the toe and heel of gear tooth.

SATISFACTORY TOOTH CONTACT
(GEARS LOADED)

Set used hypoid gear to have the tooth contacts to match wear patterns. Hand rolled patterns of used gears will be smaller in area and should be at the toe end of wear patterns.

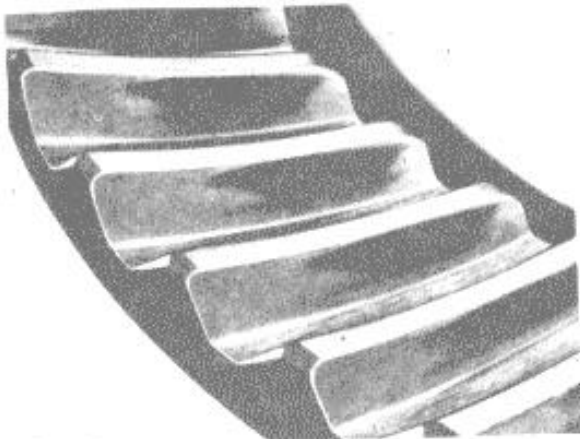

A high contact indicates pinion is too far out. Set the pinion to the correct depth by removing shims under the pinion cage. Slight outward movement of hypoid gear may be necessary to maintain correct backlash.

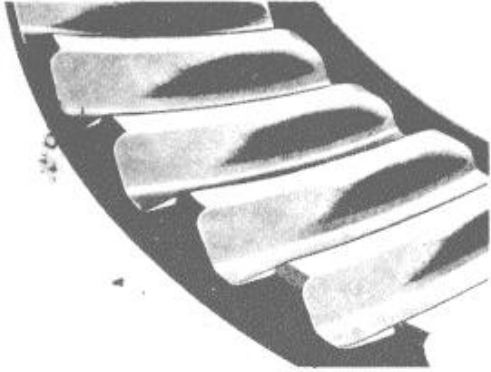

A low contact indicates pinion is too deep. Set the pinion to the correct depth by adding shims under the pinion cage. Slight inward movement of the hypoid gear may be necessary to maintain correct backlash.

8. Install Thrust Screw or Block.

- A. Remove carrier from stand and position with back face of hypoid or spiral bevel gear upward.

NOTE

CURRENT CARRIER DESIGNS EMPLOY ONLY THE THRUST SCREW, WHICH MAY REPLACE THE THRUST SCREW AND BLOCK ASSEMBLY.

- B. Remove adjusting screw and lock nut.

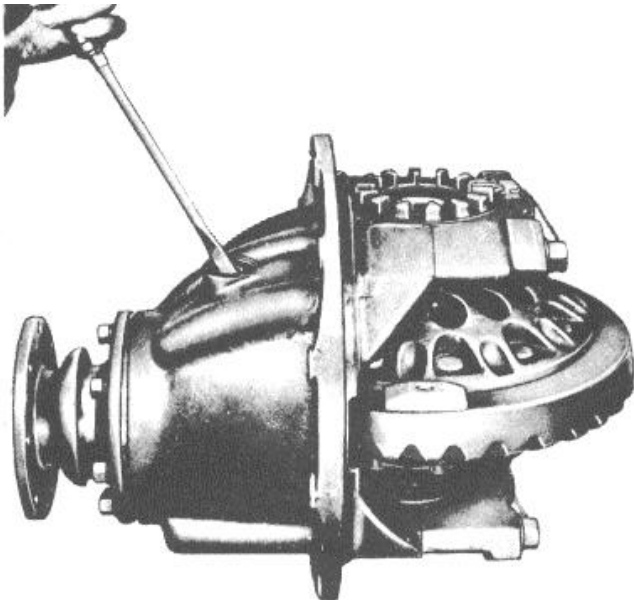

- C. If a thrust block is employed, place thrust block on rear face of hypoid gear and rotate gear until the hole in the thrust block is aligned with the adjusting screw hole.

- D. Install thrust screw and lock nut and tighten thrust screw sufficient to locate thrust block firmly against back face of hypoid gear.

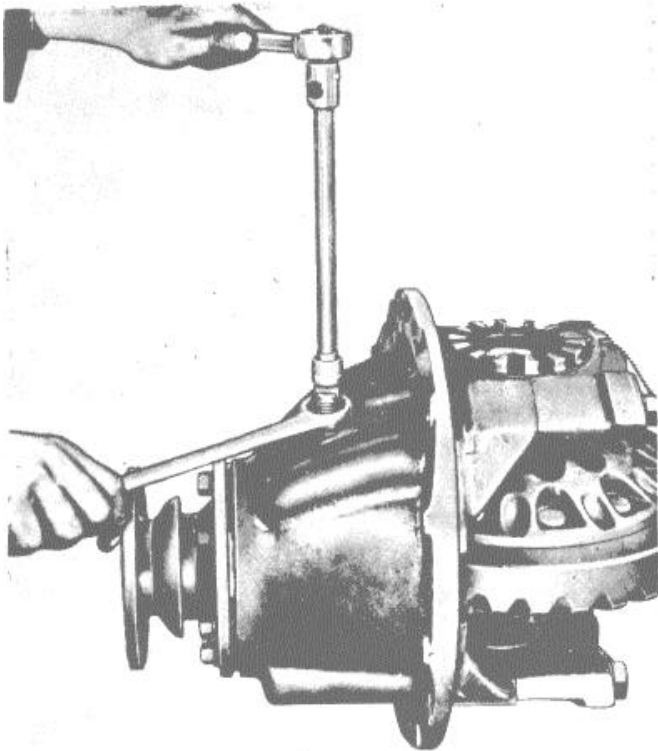

- E. To secure the correct adjustment of .010"-.015" clearance, loosen adjusting screw (or thrust screw) 1/4 turn and lock securely with nut.

- F. Recheck to assure minimum clearance of .010" during full rotation of bevel gear.

CLEAN AND INSPECT HOUSING.

- A. Remove any accumulation of dirt, grit or gum from housing bowl and sleeves. Clean housing thoroughly with solvent and blow dry with compressed air.
- B. Inspect housing for cracks, loose studs, nicks, and burrs at machined surfaces. Remove nicks and burrs with stone or file. Make all necessary repairs or parts replacement before installing drive unit in housing.

ASSEMBLE DRIVE UNIT.

- C. Install new drive unit to housing gasket over housing studs.

Roll carrier into position on roller jack. Start carrier into housing with four flat washers and nuts equally spaced.

NOTE

DO NOT DRIVE CARRIER INTO HOUSING WITH A HAMMER AT THE CARRIER STUD FLANGE. THE FLANGE MAY EASILY BE DISTORTED AND CAUSE SEVERE OIL LEAKAGE. INSTALL LOCK WASHERS AND STUD NUTS ON ANY STUDS UNDER CARRIER HOUSING OFFSETS. IT IS IMPOSSIBLE TO START THESE NUTS AFTER CARRIER IS DRAWN INTO HOUSING.

- D. Tighten the four nuts over flat washers alternately to draw carrier squarely into axle housing.

- E. If necessary, remove nuts and flat washers and install tapered dowels, lock washers and stud nuts. Tighten to the correct torque.
- F. Connect universal at pinion shaft.
- G. Install axle shafts.

Preparation For Storage.

In the event the carrier is a spare and may not be immediately installed, all gears and bearings should be thoroughly oiled and the carrier placed in a dustproof container.

LUBRICATION.

Proper lubrication of the drive units is extremely important. Our "Standard" recommended lubricant is Rockwell-Standard Specification 0-76, 0-76-A, 0-76-B or 0-76-D SAE 140 viscosity, multipurpose gear lubricant. Unusual operating conditions such as extremes in climatic temperatures may require lubricants of "Optional" viscosities. However, experience has shown that the use of an SAE 140 viscosity grade lubricant will result in longer gear life. Refer to Field Maintenance Manual No. 1, "Lubrication", for detailed information.

Since Rockwell-Standard lubricant specifications are periodically revised, always refer to Field Maintenance Manual No. 1 for current complete lubricant specifications and applications.

- A. Fill axle housing to the correct level with specified lubricant.
- B. Lubricate universal joint.
- C. Jack up both rear wheels and operate vehicle in high transmission gear at approximately 25 to 30 miles per hour for five minutes to assure satisfactory lubrication of all parts of the carrier assembly.

Do not operate with one wheel jacked up. Operation in this manner will result in overheating the differential spider with resultant galling or shearing of the spider pins.

Both wheel brakes should be free to allow both wheels to rotate at approximately the same speed.

New and Reconditioned Axle Service.

The original rear axle lubricant should be drained at the end of the drive-away or before the maximum of 3,000 miles prior to placing the vehicle in regular service. Drain the lubricant initially used in the assembly following reconditioning at the same interval. Completely drain the lubricant while the unit is warm.

Fill axle housings to bottom of level hole with specified lubricant with the vehicle level.

Regular Axle Service.

Refer to Field Maintenance Manual No. 1, "Lubrication", for recommended service interval.

Completely drain the lubricant while the unit is warm.

Some newer model axles have a smaller tapped and plugged hole located near and below the housing lubricant level hole. This smaller hole has been provided for the use of a lubricant temperature indicator only and should not be used as a fill or level hole.

Magnetic Drain Plugs.

Magnetic drain plugs perform the vital function of trapping small metallic particles that circulate in the lubricant, through the gears and bearings, causing rapid wear and premature failure. The magnet must be strong enough to firmly hold the particles under service conditions. We recommend plugs with elements having a minimum pick-up capacity of 2 pounds of low carbon steel in plate or flat bar form. See Plug section in Field Maintenance Manual No. 1.

Spare clean plugs should be kept on hand for replacement at regular intervals. The change schedule can easily be established by periodic plug examination.

Front Axle.

DISASSEMBLY. (ILLUS. 4-47)

1. Remove the Steering Knuckle.

To remove the steering knuckle assembly from the axle center, use the following procedures:

- A. Jack up the front end of vehicle so that tires clear floor. Block up securely at this position and remove jacks.

CAUTION

DO NOT ATTEMPT TO DISASSEMBLE OR PERFORM STEERING KNUCKLE REPAIRS WITH VEHICLE SUPPORTED BY JACKS ONLY.

- B. Remove the hub cap from hub. Then, remove jam nut, wheel bearing adjusting nut and lock washers from knuckle spindle.
- C. Remove the outer wheel bearing cone.
- D. Remove wheel and hub assembly.
- E. Remove brake air chambers on units equipped with air brakes, or hydraulic lines on units equipped with hydraulic brakes.

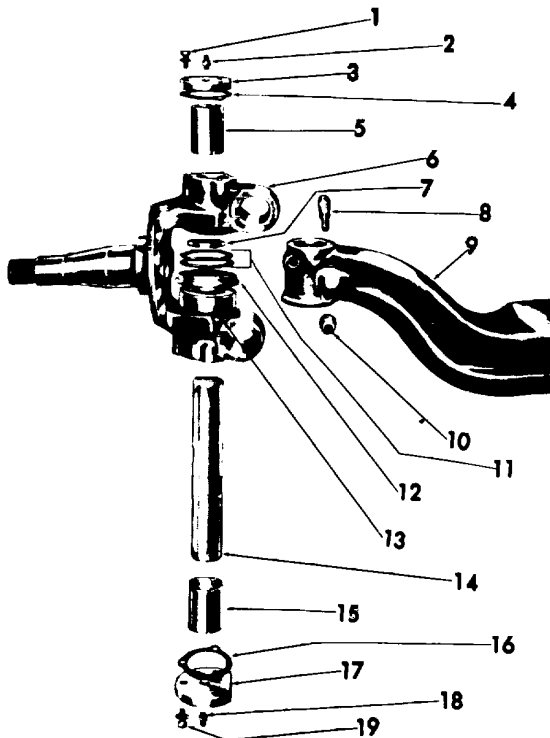

- 1. Capscrew & Lock Washer
- 2. Grease Fitting
- 3. Upper Steering Knuckle Cap
- 4. Gasket
- 5. Upper Knuckle Pin Bushing
- 6. Steering Knuckle
- 7. Upper Grease Seal
- 8. Draw Key
- 9. Axle Center
- 10. Draw Key Nut
- 11. Shims
- 12. Lower Seal & Gasket Assembly. (If Req'd)
- 13. Thrust Bearing & Gasket Assembly. (If Req'd.)
- 14. Knuckle Pin
- 15. Lower Knuckle Pin Bushing
- 16. Gasket
- 17. Lower Steering Knuckle Cap
- 18. Grease Fitting
- 19. Capscrew & Lock Washer

SEALED KNUCKLE PIN

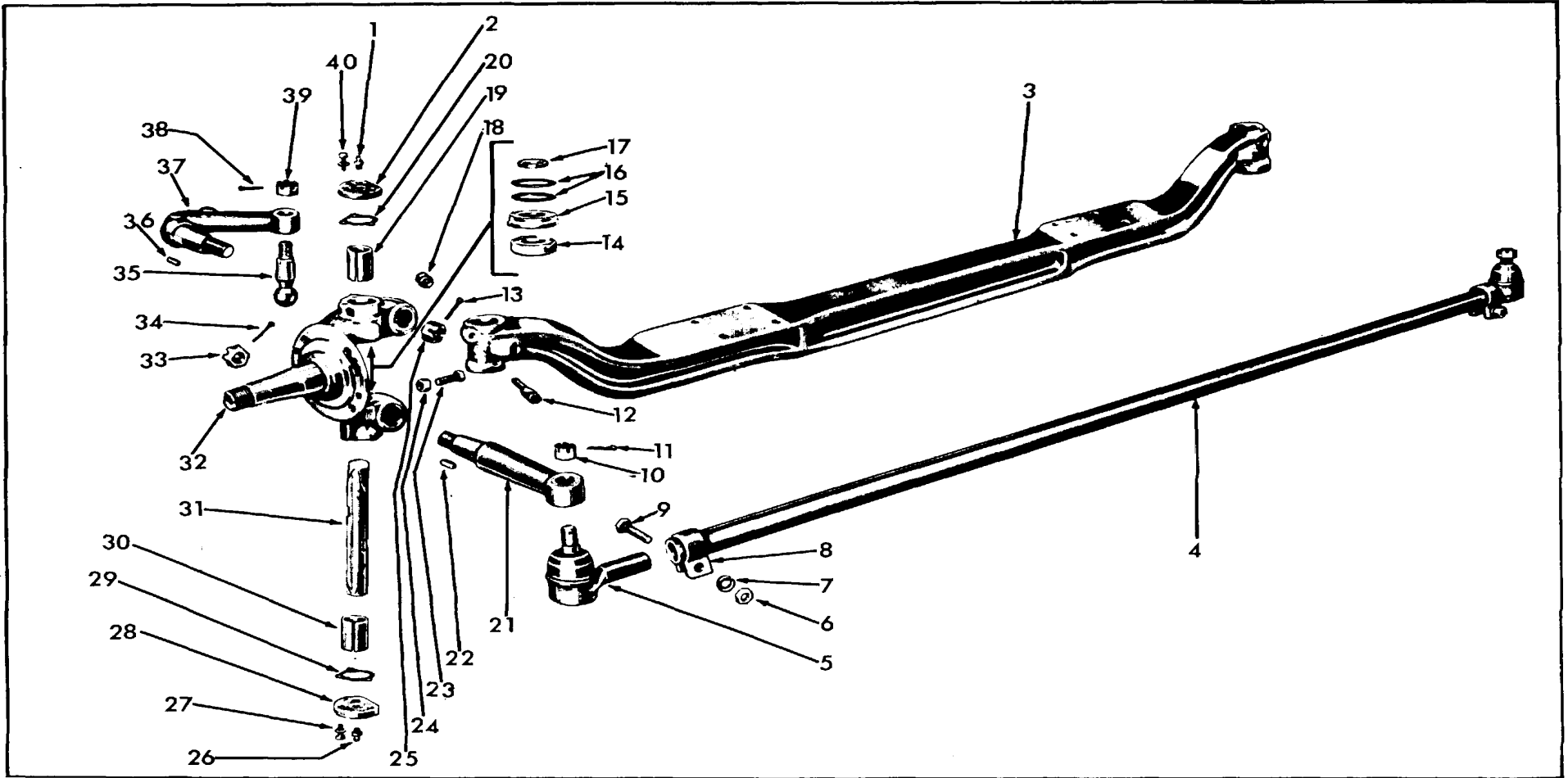

- | | | | |
|-------------------------|---|----------------------------|----------------------------|
| 1. Grease Fitting | 11. Cotter Pin | 21. Cross Tube Arm | 31. Knuckle Pin |
| 2. Steering Knuckle Cap | 12. Draw Key | 22. Cross Tube Arm Key | 32. Steering Knuckle |
| 3. Axle Center | 13. Cotter Pin | 23. Stop Screw | 33. Cross Tube Arm Nut |
| 4. Cross Tube Assembly | 14. Thrust Brg. & Gasket Assembly (If Req'd.) | 24. Lock Nut | 34. Cotter Pin |
| 5. Tie Rod End Assembly | 15. Lower Seal & Gasket | 25. Steering Arm Nut | 35. Steering Arm Ball |
| 6. Clamp Nut | 16. Shims | 26. Grease Fitting | 36. Steering Arm Key |
| 7. Lock Washer | 17. Upper Seal | 27. Capscrew & Lock Washer | 37. Steering Arm |
| 8. Clamp | 18. Draw Key Nut | 28. Steering Knuckle Cap | 38. Cotter Pin |
| 9. Bolt | 19. Bushing | 29. Gasket | 39. Steering Arm Ball Nut |
| 10. Tie Rod End Nut | 20. Gasket | 30. Bushing | 40. Capscrew & Lock Washer |

Illustration 4-47. Front Axle.

F. Remove brake assembly from steering knuckle if brake service is required.

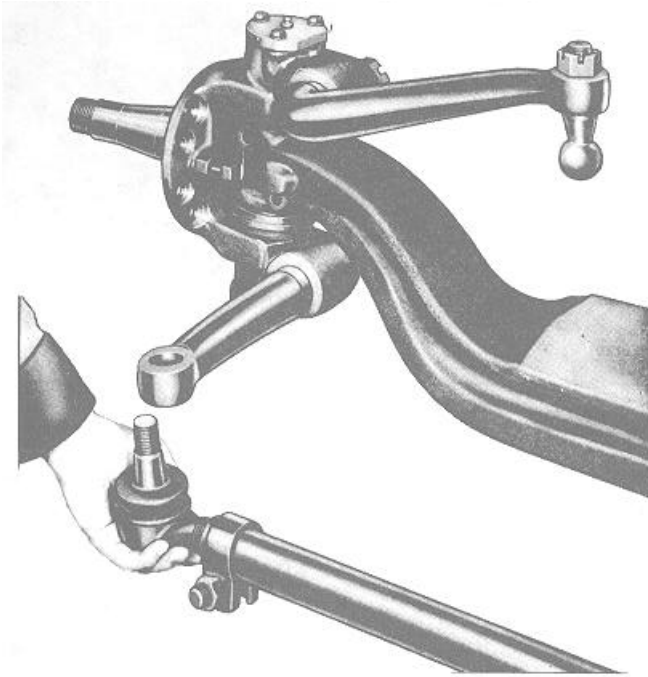

G. Remove tie rod end nut and disassemble cross tube assembly from cross tube arm.

H. Remove cross tube arm nut, and steering arm nut and disassemble cross tube arm and steering arm from knuckle.

NOTE

IT IS NOT NECESSARY TO REMOVE CROSS TUBE ARM OR STEERING ARM FROM KNUCKLE UNLESS SERVICE IS NECESSARY.

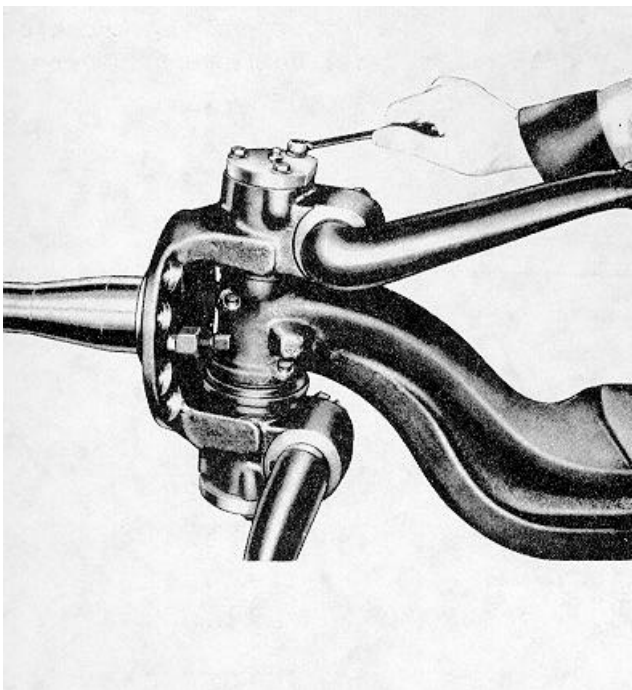

J. Remove steering knuckle cap capscrews, caps and gaskets from top and bottom of knuckle. Some models may employ an integral gasket in the lower seal and thrust bearing.

- K. Remove draw key nut if used, and tap out knuckle pin draw keys from the small end using a suitable drift.

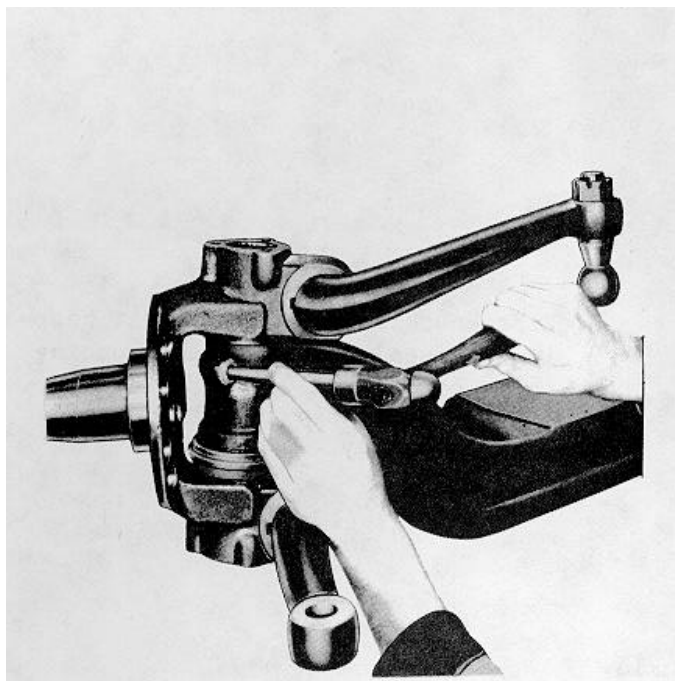

CAUTION

DO NOT STRIKE THESE HARDENED STEEL PIECES DIRECTLY WITH A STEEL HAMMER.

- L. Use a bronze drift and tap knuckle pin out of axle center and steering knuckle.

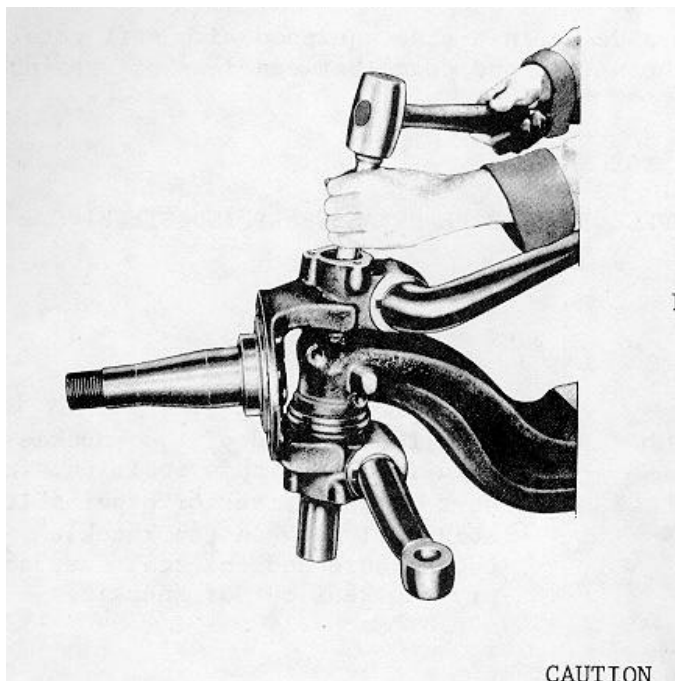

CAUTION

DO NOT STRIKE THESE HARDENED STEEL PIECES DIRECTLY WITH A STEEL HAMMER.

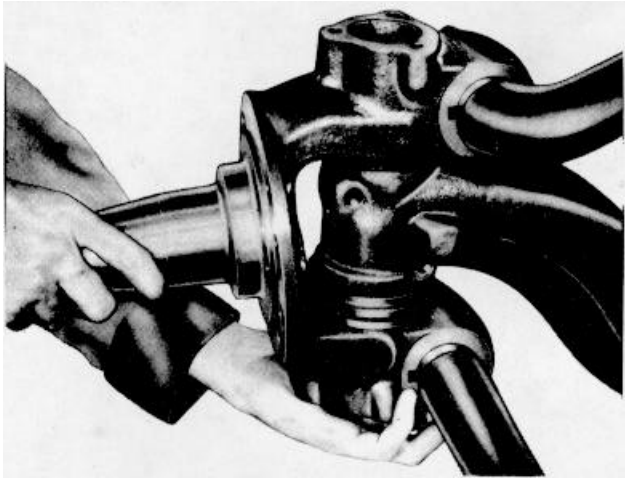

- M. Lift knuckle assembly, thrust bearing and seal assembly, and spacing shims off of axle center. Retain shims, thrust bearing, and seal for reassembly.

2. Remove Upper Seal from Steering Knuckle.

With the steering knuckle assembly removed from the axle center, inspect the upper grease seal for tears, rips and deterioration. Do not attempt to remove the seal from the steering knuckle unless replacement is necessary. If seal must be removed, follow these procedures:

- A. Place steering knuckle bottom side up in a vise equipped with soft metal jaws. Position upper knuckle boss (top end down) between Jaws of vise and lock securely.

NOTE

TO FACILITATE POSITIONING KNUCKLE IN VISE BRAKE ASSEMBLY AND STEERING ARM MUST BE REMOVED.

- B. With the top end of the knuckle held firmly in this position, insert a screwdriver or other suitable tool between the knuckle counterbore and the seal case and pry the seal out of knuckle.
- C. Remove knuckle from vise for inspection.

CLEANING.

Parts having ground and polished surfaces such as knuckle pins, knuckle pin sleeves, bearings and spindles, should be cleaned in a suitable solvent such as

kerosene or diesel fuel oil.

NOTE

GASOLINE SHOULD BE AVOIDED. DO NOT CLEAN THESE PARTS IN A HOT SOLUTION TANK OR WITH WATER AND ALKALINE SOLUTIONS SUCH AS SODIUM HYDROXIDE, ORTHOSILICATES OR PHOSPHATES.

Drying.

Parts should be thoroughly dried immediately after cleaning. Use soft, clean, lintless, absorbent paper towels or wiping rags free of abrasive material, such as lapping compound, metal filings or contaminated oil. Bearings should never be dried by spinning with compressed air.

Corrosion Prevention.

Parts that have been cleaned, dried, inspected and are to be immediately reassembled should be coated with light oil to prevent corrosion. Spindles, knuckle pins or sleeves that are to be stored for any length of time should be treated with a good rust preventative and wrapped in oiled paper and boxed to keep dry and clean.

INSPECT.

It is impossible to overstress the importance of careful and thorough inspection of steering knuckle components prior to reassembly. Thorough visual inspection for indications of wear or stress, and the replacement of such parts as are necessary will eliminate costly and avoidable front end difficulties.

Steering Knuckle and Knuckle Pin.

- A. Inspect the steering knuckle thrust bearing, wheel bearing cones and cups. Replace if rollers or cups are worn, pitted or damaged in any way. If wheel bearing cups are to be replaced, remove from hubs with a suitable puller. Avoid the use of drift and hammers as they may easily mutilate cup bores.
- B. Inspect the steering knuckles and replace if indications of weakness or excessive wear is found.
- C. Check knuckle pin for excessive wear. Compare with correct specification.
- D. Check upper knuckle pin seal for rips, tears and excessive wear. Do not remove upper seal from steering knuckle counterbore unless replacement is necessary. If seal must be replaced, follow removal procedures.
- E. Remove lower knuckle pin seal from thrust bearing case and inspect seal for wear, rips and tears.
- F. Check thrust bearing and lower seal gaskets for wear. Some axles may employ an integral gasket in the lower seal or thrust bearing.
- G. Check knuckle pin bushings for flaking and galling. Compare with correct specification. Do not remove bushings from steering knuckle unless replacement is necessary.

NOTE

ANY INDICATION OF LOOSENESS IN THE TOTAL STEERING LINKAGE ARRANGEMNT UNDER NORMAL STEERING LOADS IS SUFFICIENT CAUSE TO IMMEDIATELY CHECK ALL PIVOT POINTS FOR WEAR, REGARDLESS OF ACCUMULATED MILEAGE. STEERING LINKAGE PIVOT POINTS SHOULD BE CHECKED EACH TIME THE AXLE ASSEMBLY IS LUBRICATED. IF ANY INDICATION OF LATERAL MOVEMENT IS FOUND, TIE ROD ENDS SHOULD BE REMOVED FOR INSPECTION. LOOSENESS AT THE STEERING LINKAGE PIVOT POINTS CAN BE VISUALLY DETECTED DURING MOVEMENT OF THE VEHICLE STEERING WHEEL IN DRY PARK POSITION.

Tie Rod End.

- A. Check seals visually for any indications of damage. Also check to make sure seal is securely seated on socket. If tie rod end has a grease fitting, replace damaged seals. Tie rod ends not having greasing provision should be replaced if seals are damaged or loose.

CAUTION

ROCKWELL-STANDARD DOES NOT RECOMMEND ATTEMPTS TO SALVAGE DAMAGED ENDS BY REPACKING AND REPLACING THE BOOT SEAL ON NON-GREASABLE ENDS.

- B. Check the turning torque value between the tie rod end assembly stud and the ball cavity. If torque value is less than five (5) inch pounds, the tie rod end assembly should be replaced. This is not to say the end assembly will fail at this point, but it can no longer provide the type of steering control designed into it once lateral movement develops between the stud and ball cavity.

REPAIRS.

- A. In the interest of safety and preserving the service life of front axle assemblies, Rockwell-Standard recommends that front axle assemblies NOT be repair welded. Repair welding can detract from the structural integrity of a component, particularly as to heat treated parts where the benefit of heat treatment may be nullified by the welding.

Since it can be extremely hazardous and detrimental to repair weld components of any kind, repair welding can be approved only where stringent controls are imposed and equipment, customarily located only at manufacturing facilities, is employed, so as to minimize the potentially detrimental effects of repair welding.

In deciding whether to repair or scrap any damaged part, always keep in mind that we as manufacturers, never hesitate to scrap any part which is in any way doubtful.

- B. Straightening of bent parts should be done cold. Various components are heat-treated and hot straightening would destroy some of the heat treatment.

Axle centers (that are bent no more than 1/2") may be straightened cold; if bent more than 1/2" they should be replaced.

- C. Bent steering arms, cross tube arms or steering knuckles should be replaced rather than straightened. (It is not necessary to remove steering arms and cross tube arms from the knuckle unless replacements are required).

REPLACEMENT OF STEEL BACKED BRONZE STEERING KNUCKLE BUSHINGS.

Service replacement of steering knuckle bushings can be accomplished with a suitable press, and a bushing removal and installation bar. The bar (shown in the sketch below) can be made from a piece of round bar stock which is ground with a step to serve as a pilot. The dimension of the "X" diameter should be 0.10" less than the specified bushing bore, and the dimension of the "Y" diameter should be 0.10" less than the steering knuckle bore. The pilot of this tool prevents collapse or distortion of bushing during installation. To facilitate the removal and the installation of knuckle bushings, follow these procedures:

- A. Press worn bushing out of knuckle with a removal and installation bar of appropriate size.
- B. Place new bushing on the small diameter of the bar and press it into the steering knuckle in three or more steps. This allows the bushing to align itself with the bore.

First, press bushing into knuckle approximately 1/8" and relieve press pressure, press bushing in another 1/2" and relieve press pressure. The bushing can now be pressed in until it is flush with the surface of the upper seal counterbore for the top, or with the inside surface of the lower knuckle boss for the bottom.

- C. To finish a bushing, either a burnishing bar or reamer must be employed. The dimensional limits of finished bushing must correspond to the correct specification for the desired axle.

Utilization of burnishing ball for this operation must be avoided, as it does not insure a true alignment between the two bushings.

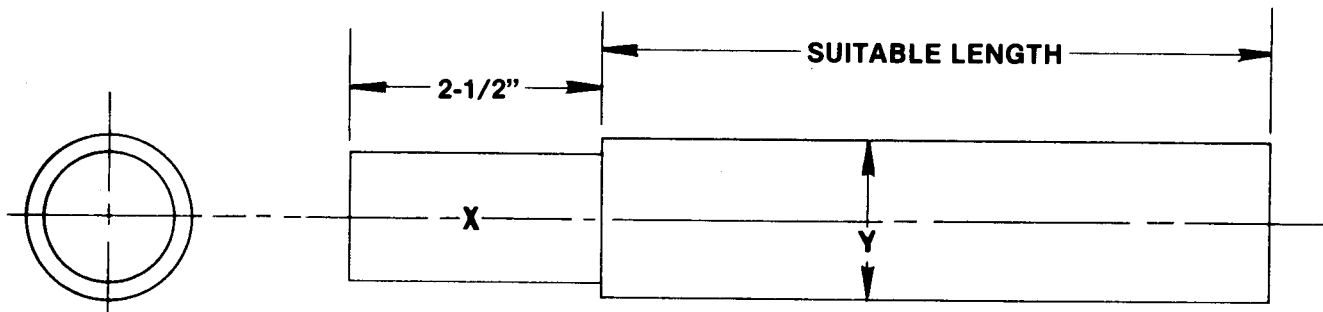

BUSHING REMOVAL AND INSTALLATION TOOL

Dimension "X" is 0.10" less than the bushing bore.
 Dimension "Y" is 0.10" less than the steering knuckle bore.

REASSEMBLY. (Table 4-3).

1. Grease Seal Installation.

It is impossible to overstress the importance of proper grease seal installation in both the top and bottom positions of the steering knuckle. Incorrect installation could result in premature lubricant contamination and a need for more frequent lubrication and overhaul service intervals. Therefore, for maximum, operating service from the front axle assembly grease seals should be installed by the following procedures.

2. Install Upper Grease Seal Installation.

If it was necessary to remove the upper seal from the steering knuckle, use the following to install a new seal.

- A. Place steering knuckle bottom side up in a vise equipped with soft metal protectors. Position upper knuckle boss (top end down) between Jaws of vise and lock securely.
- B. With the top end of the knuckle held firmly in this position, place the seal over the knuckle counterbore, with the rubber lip facing up.

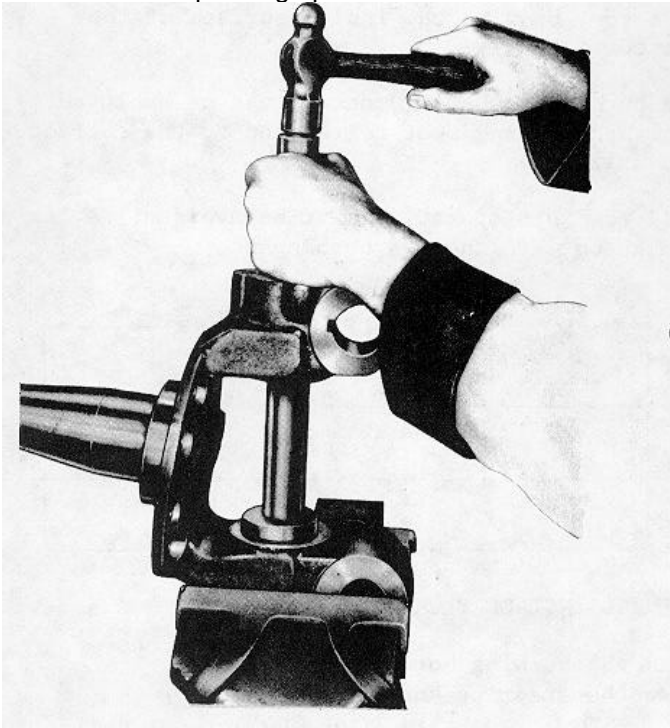

- C. Using a suitable sleeve and a bronze drift, tap the seal into the knuckle counterbore until it bottoms.

3. Install Thrust Bearing and Lower Seal Installation.

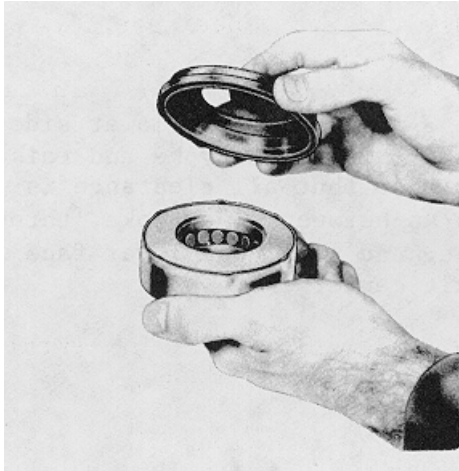

- A. Before attempting to install the thrust bearing and lower seal assembly on the steering knuckle, make certain the lower seal is positioned correctly over the thrust bearing retainer lip.

NOTE

TO FACILITATE CORRECT POSITIONING, HOLD THRUST BEARING WITH THRUST BEAR GASKET FACE DOWN. THEN, SNAP LOWER SEAL OVER THE THRUST BEARING CHAMFER SIDE AS SHOWN.

- B. With the knuckle pin hole in the axle center clean and dry, position and support the steering knuckle on the axle.

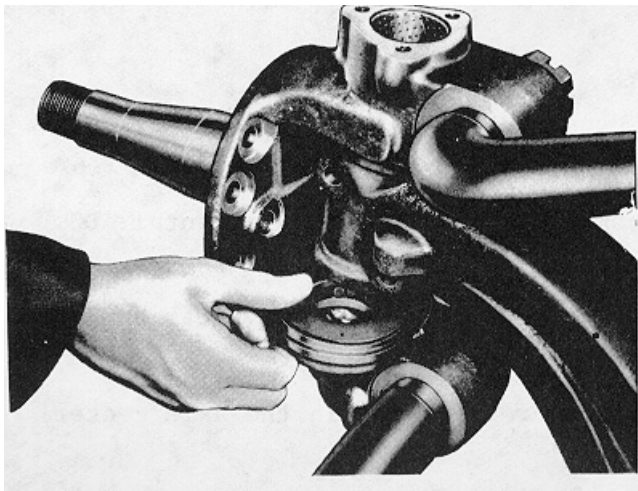

- C. With the seal positioned over the thrust bearing, slide the thrust bearing and lower seal assembly between the lower face of the axle center and the lower knuckle boss.

NOTE

THE BOTTOM SIDE OF THE THRUST BEARING MUST BE SEATED ON THE FACE OF THE LOWER KNUCKLE YOKE. THE LOWER SEAL MUST BE POSITIONED BENEATH THE BOTTOM FACE OF THE AXLE CENTER.

4. Install Knuckle Pin Installation.

- A. Align the knuckle pin holes of the steering knuckle, axle center, and thrust bearing and lower seal assembly.

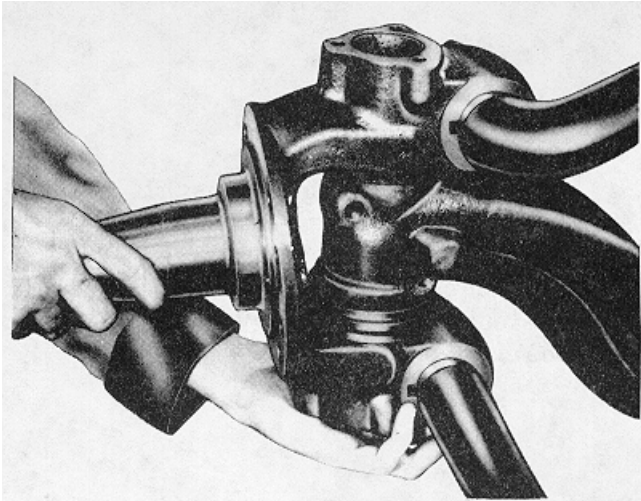

- B. Place a jack under the lower side of steering knuckle yoke and raise knuckle so that all clearance is taken up between lower yoke, thrust bearing and seal, and lower face of axle center end.

- C. Align knuckle pin flat (or flats) to mate with draw key holes, and tap knuckle pin through knuckle yoke, axle center and thrust bearing from top or bottom side.

CAUTION

DO NOT STRIKE THESE HARDENED STEEL PIECES DIRECTLY WITH A STEEL HAMMER.

- D. Install the draw keys so that the flat on the key mates with the corresponding flat on the knuckle pin.

NOTE

BEFORE SETTING THE DRAW KEY, CENTER KNUCKLE PIN TO EQUALIZE GAP BETWEEN UPPER AND LOWER GAP MOUNTING SURFACES.

Draw keys should be installed one from each side of the axle center. DO NOT INSTALL BOTH KEYS FROM THE SAME SIDE.

- E. On models employing threaded draw keys, install the draw key nuts and tighten to correct torque.

On models without threaded draw keys, secure each key in the axle center by prick punching edge of hole.

- F. Check the clearance between the top face of upper axle center end and lower face of upper knuckle pin boss.

Rockwell-Standard does NOT recommend measurement of clearance tolerances on steering knuckles with shim gauges. Measurement by shim gauges will tend to give false readings.

Procedure for measurement of end play with dial indicator is as follows:

1. Set up dial indicator graduated in thousandths with the mechanical clamp or magnetic base affixed to the knuckle spindle such that the knuckle can be turned freely.

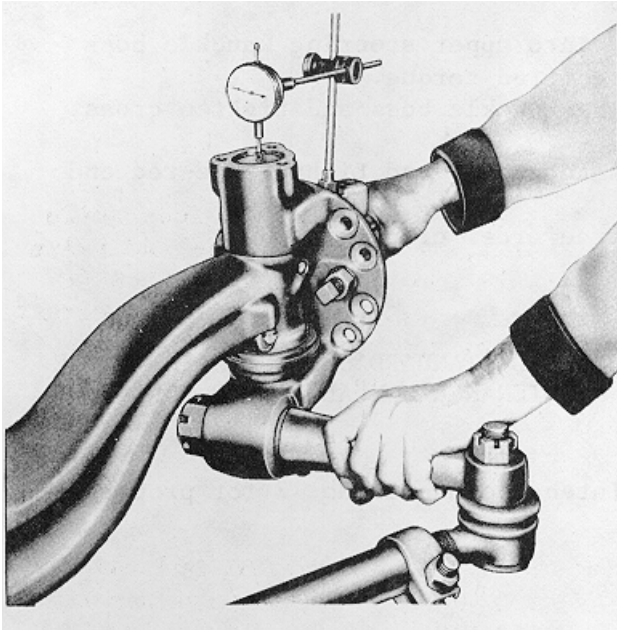

2. Place the dial indicator plunger on the exposed end of the knuckle pin such that its line of action is approximately parallel to the knuckle pin center line.

3. Zero the dial indicator.

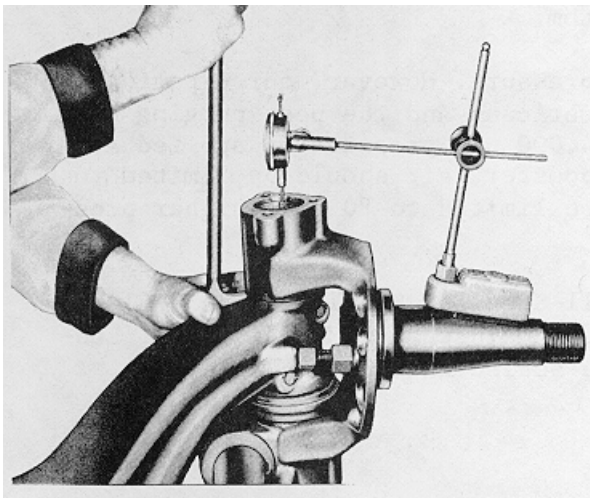

4. Using a suitable lever or block and lever, lift the knuckle and take the dial reading.

5. Turn the knuckle.
6. Repeat steps one through five for three knuckle positions.
7. Three steering knuckle positions are necessary to measure the end play with the dial indicator. The positions are: full right turn, full left turn and the straight ahead position.

NOTE

CURRENT SPECIFICATIONS ADD SHIMS AS REQUIRED TO MAINTAIN .005" MINIMUM TO .025" MAXIMUM END PLAY THRU FULL RANGE OF TURN. GROWTH THROUGH NORMAL WEAR MAY EXCEED THE SPECIFIED MAXIMUM BY .040".

5. Complete Reassembly.
 - A. Install gaskets and steering knuckle caps at top and bottom of steering knuckle bosses. Install capscrews and lockwashers and tighten to specified torque.
 - B. Install steering arm and ball assembly into upper steering knuckle boss and tighten steering knuckle nut to specified torque.
 - C. Install cross tube arm to lower steering knuckle boss and tighten cross tube arm nut to specified torque.
 - D. Assemble cross tube assembly and cross tube arm, and tighten tie-rod end nut to correct torque.
 - E. Install wheel and hub assembly in reverse order of disassembly.

NOTE

IF BRAKES REQUIRE SERVICE, REFER TO ROCKWELL-STANDARD'S FIELD MAINTENANCE MANUAL NO. 4 FOR CAM BRAKES, OR FIELD MAINTENANCE MANUAL NO. 4R FOR STOPMASTER BRAKES.

- F. Refer to Rockwell-Standard's Field Maintenance Manual No. 2 for proper Wheel bearing adjustment.

LUBRICATION.

Vehicle must be removed from blocks and jacks for knuckle pin lubrication to assure purging of grease. Force grease through the top and bottom lube fittings until grease purges through the shim gap when greasing the top and through the thrust bearing seal lip when greasing the bottom.

It is not necessary to exceed 4,000 psi pump pressure. However, our experience indicates that the base distribution of new lubricant and the best purging of old lubricant is obtained when approximately 4,000 psi pressure is applied at the grease gun nozzle. Thus, using a 40 to 1 booster, air should be limited to 100 psi; using a 50 to 1 booster, air should be limited to 80 psi. Higher pressures are not recommended.

The particular grease used should meet Rockwell-Standard Specification 0-617-A or optional 0-617-B in Rockwell-Standard's Field Maintenance Manual No. 1, Lubrication". Recommended lube intervals for the sealed knuckle pin is 24,000 miles.

TABLE 4-3. TORQUE VALUES

LOCATION	DIAMETER	NO. THREADS	TORQUE - MINIMUM	LB. FT. MAXIMUM
*Tie rod end nut torque.	9/16"	18	42	55
	5/8"	16	60	85
	5/8"	18	60	85
	3/4"	16	90	125
	7/8"	14	165	230
	1"	14	250	350
	1 1/8"	12	350	490
*Tie rod clamp bolt (torque values for fasteners using lockwire or cotter pins)	5/16"	24	10	15
	3/8"	24	25	35
	7/16"	20	20	30
	1/2"	20	40	50
	5/8"	18	50	60
Tie rod clamp bolt (torque values for fasteners using locknuts)	5/16"	24	6	8
	3/8"	24	16	20
	7/16"	20	33	40
	1/2"	20	40	50
	5/8"	18	45	55
*Steering arm ball nut	5/8"	16	60	85
	5/8"	18	60	85
	3/4"	16	90	125
	7/8"	14	165	230
*Steering arm nut	7/8"	14	260	370
	1"	14	390	545
	1 1/8"	12	560	785
	1 1/4"	12	770	1075
	1 1/2"	12	1370	1900
Draw key nut	3/8"	24	30	45

*Assemble nut in accordance with chart shown. Use wrench torque given to line up cotter pin hole. Do not back off.

Universal Joints and Drive Shafts

DISASSEMBLY '

1. Remove the two snap rings.
2. Get a block of soft metal with a hole large enough for the bearing to pass through.
3. Place the round bearing over the hole and hammer on the opposite bearing with a soft metal punch until the body of the spider hits the inside forks of the yokes. It may be necessary to tap the outside fork of the yoke with a hammer until the bearing pops out.
4. Repeat the procedure for the other bearing, then remove the spider.
5. Insert the spider into the bearing holes in the forks of the yokes.

ASSEMBLY

6. Insert the bearings into the holes in the forks.
7. Put the assembly in a vise and press the bearings together until the bearings are flush with the forks.
8. Assemble the snap rings in the snap ring grooves. The bearings may have to be tapped inward enough so the snap ring groove is in a position to receive the snap rings. After the snap rings are in place, tap the outside of the yoke near the bearings to draw the snap rings against the machined inner surface of the yoke arms.

INSTALLATION

9. The first operation is to attach the fitting yokes to the two shafts to be connected. Care should be used when doing this, so as not to nick or bend the flanges to which the bearings are fastened. Then the yoke retaining nut is tightened to prevent it coming off the shaft.
10. The next operation is to bring one end of the universal joint and shaft up against one of the fitting yokes. It will be noted that one of the bearings is inserted in the keyway in the yoke with the male arced surface pilot of the bearing, resting on the female pilot of the yoke. Due to the fact that there are cork packings between each of the bearings and the trunnions on which they fit, this cork packing must be compressed a certain amount, before it is possible to enter the male arced surface of the other bearing with the yoke pilot on the opposite side.
11. This should be done by clamping the two opposite bearings with a "C" clamp. Then push the bearings into the yoke pilot and keyway. Do not attempt to put the bolts through into the bearing until both of the bearings have found their seat on the yoke surface. The bolts are then inserted through the yoke and screwed into the bearing. It will be noted that the

pair of bearings at each end of the shaft that are to assemble to the end yokes, are held in place by means of a weld wire.

12. The weld wire has no effect on the universal joint action and need not be removed. Rather it should remain in place to hold the bearings on the spider trunnions should the universal joint have to be disassembled. Then tighten the four bolts securely. After one end of the shaft has been put in place, the shaft can be compressed in the slip joint to permit raising the other end of the shaft and then, coming forward against the yoke member proceed exactly the same as stated above.
13. Should it be necessary to disassemble the joint for instance to replace a spider or bearing-it is only necessary to remove the eight bolts (4 per each yoke), compress the shaft assembly in the slip joint and remove the spider and the four bearing assemblies.
14. It may be that some of the bearings are tight in their respective pilots and key seats, which will make it necessary to tap the top of the bearing slightly, in order to release it. Then, the spider and bearing assembly can be replaced in part or as a complete unit.
15. When installing a double universal joint assembly, it is important that both of the universal joints operate at equal angles. It is also important that the slip yoke and the yoke welded to the tube are in the same plane.

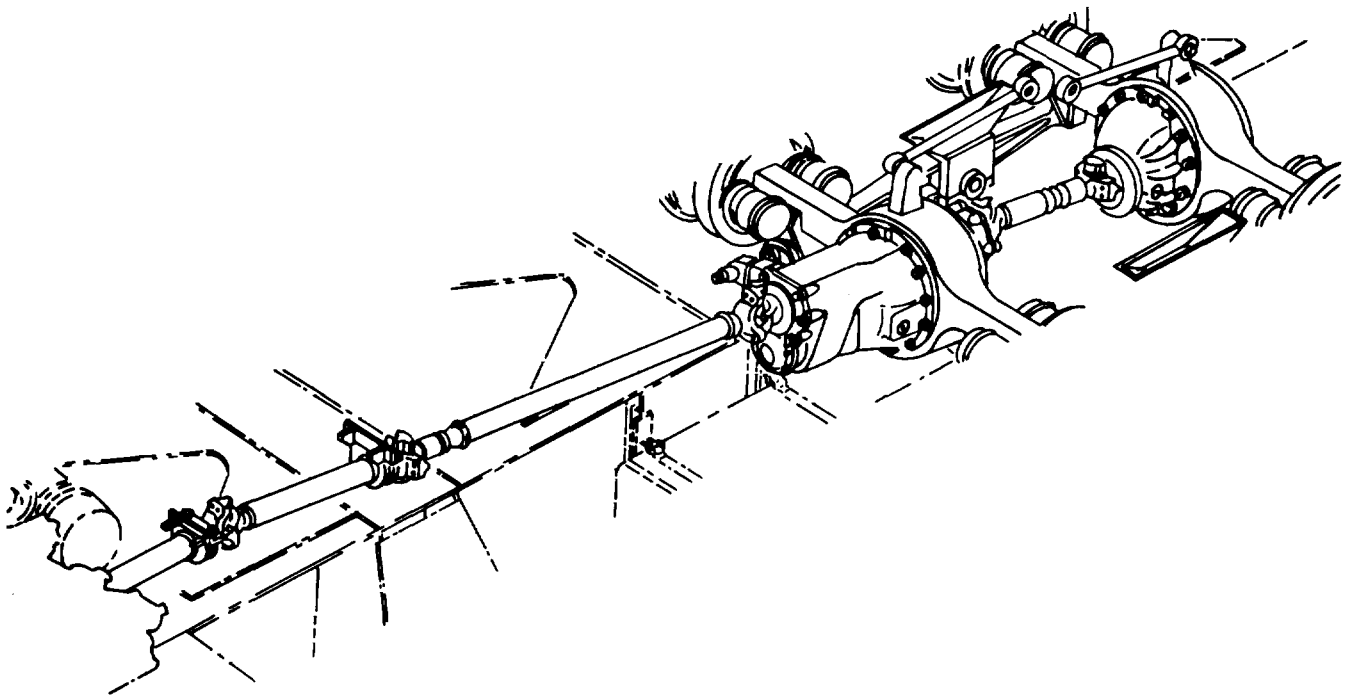

LUBRICATION.

Universal joints requiring a grease lubricant should be lubricated with any good grade of "O" chassis lubricant.

Grades 1 and 2 may be required for use in hot weather and heavy duty service. good grade of 140 mineral oil is also approved. The lubricant should be a high N melting point fine fibre grease.

The interval between lubrications depends on the types of service. An interval of 400 hours between lubrications is generally satisfactory for normal service. A 100 hour interval is recommended for heavy duty service.

When subjected to extremely severe conditions, more frequent lubrication may be required.

Lubrication must be done with a low pressure hand type grease gun or a high pressure gun with a low pressure adapter only. High pressure will rupture the cork seals.

Front Suspension. (Reyco)

INSTALLATION (Illus. 4-48).

The illustration shows the Front Suspension and specifies torque values to be applied.

Rear Suspension. (Hendrickson)

INSTALLATION (Illus. 4-49).

The illustration shows the Rear Suspension, and specified torque values to be applied.

Toe-In and Synchronization of Steering Axles.

ALIGNMENT. (Illus. 4-50).

Equipment.

1. Toe-in Alignment Gage.
2. Eight (8) Foot Straight Edge.

TOE-IN ADJUSTMENT. (Illus. 4-50).

1. Scribe a horizontal line on the tire tread of each of the front steering wheels. Rotate wheels until these marks are to the front of the carrier.
2. Place toe-in gauge at front of tires at the scribed marks. Set scale to zero.
3. Rotate wheels so scribe marks are to the rear. Place gauge at rear of wheel and set pointer on toe-in gauge; (Both readings should be taken with gauge at same height from ground).
4. Reading on scale is amount of toe-in or toe-out of wheels; (Greater distance at rear of wheel than at front is indication of toe-in).
5. Make necessary adjustment to obtain 1/8" toe-in and recheck results.
6. Tighten both tie-rod clamps.
7. Repeat above procedure for toe-in of axle #2.

STEER CYLINDER ALIGNMENT.

1. Position wheels straight and check that the two steering cylinders are at the center of their travel. (Approximately 6 inches extended).
2. Adjust as required by loosening clamp at the shaft end of each cylinder.

Axle Synchronization. (Illus. 4-50).

1. After toe-in adjustment is completed, allow wheels to rest in a level surface.
2. Place a straight edge against the hubs of the left side wheels. Steer manually until front axle is straight. (Distance from straight edge to curb side edge of rim to be the same on-both the left and right hand side of the carrier).
3. Measure distance from straight edge to a point on the forward part of the rim of axle #2.
4. Move straight edge to right hand wheels and place against the hubs. Measure distance as in item #3.

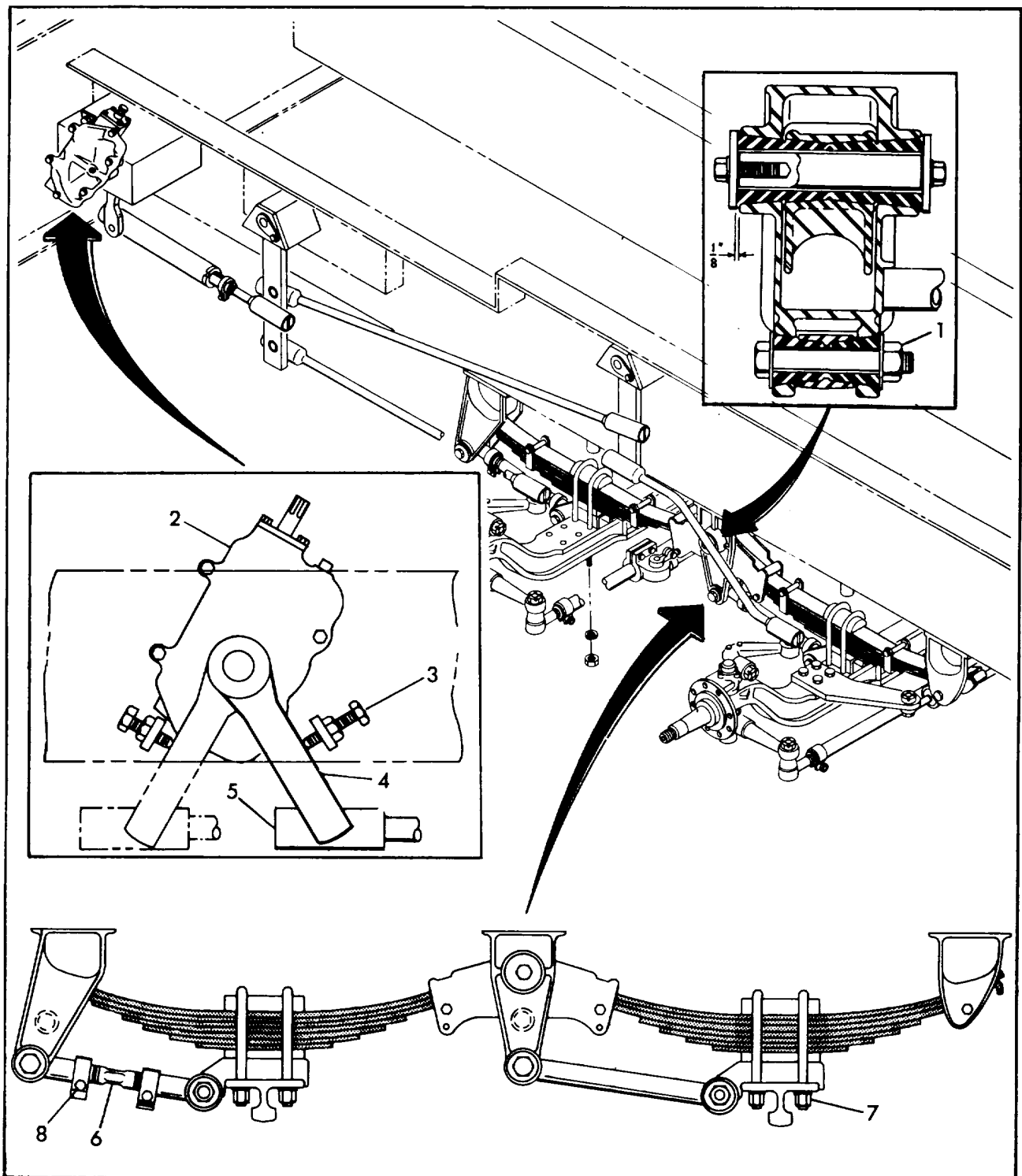

1. Bolt Torque Arm (Torque 200 ft. lbs - 8 places)
2. Steer Gear
3. Adjustment Bolt
4. Pitman Arm
5. Steer Control Valve
6. Torque Arm
7. Nut (Torque 300 ft lbs - 16 places)
8. Nut (Torque 80 ft lbs. - 4 places)

Illustration 4-48. Front Suspension.

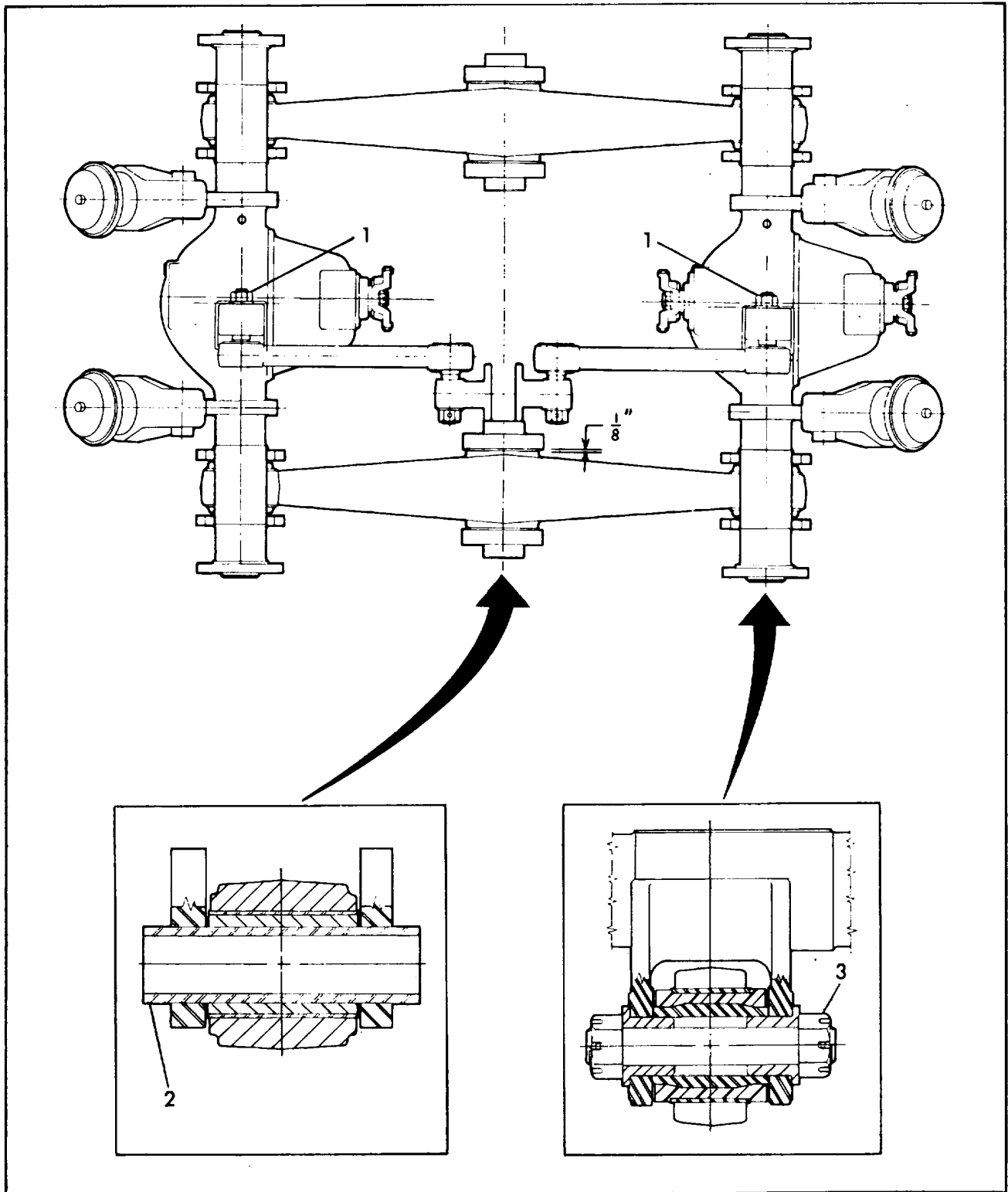

1. Locknut (Torque 175-200 ft. lbs)
2. Center Tube Lock (4). Check after first 1,000 miles and check every 10,000 miles.
3. Beam to axles Bolts (4). After first 1,000 miles and check every 10,000 miles.

Illustration 4-49. Rear Suspension.

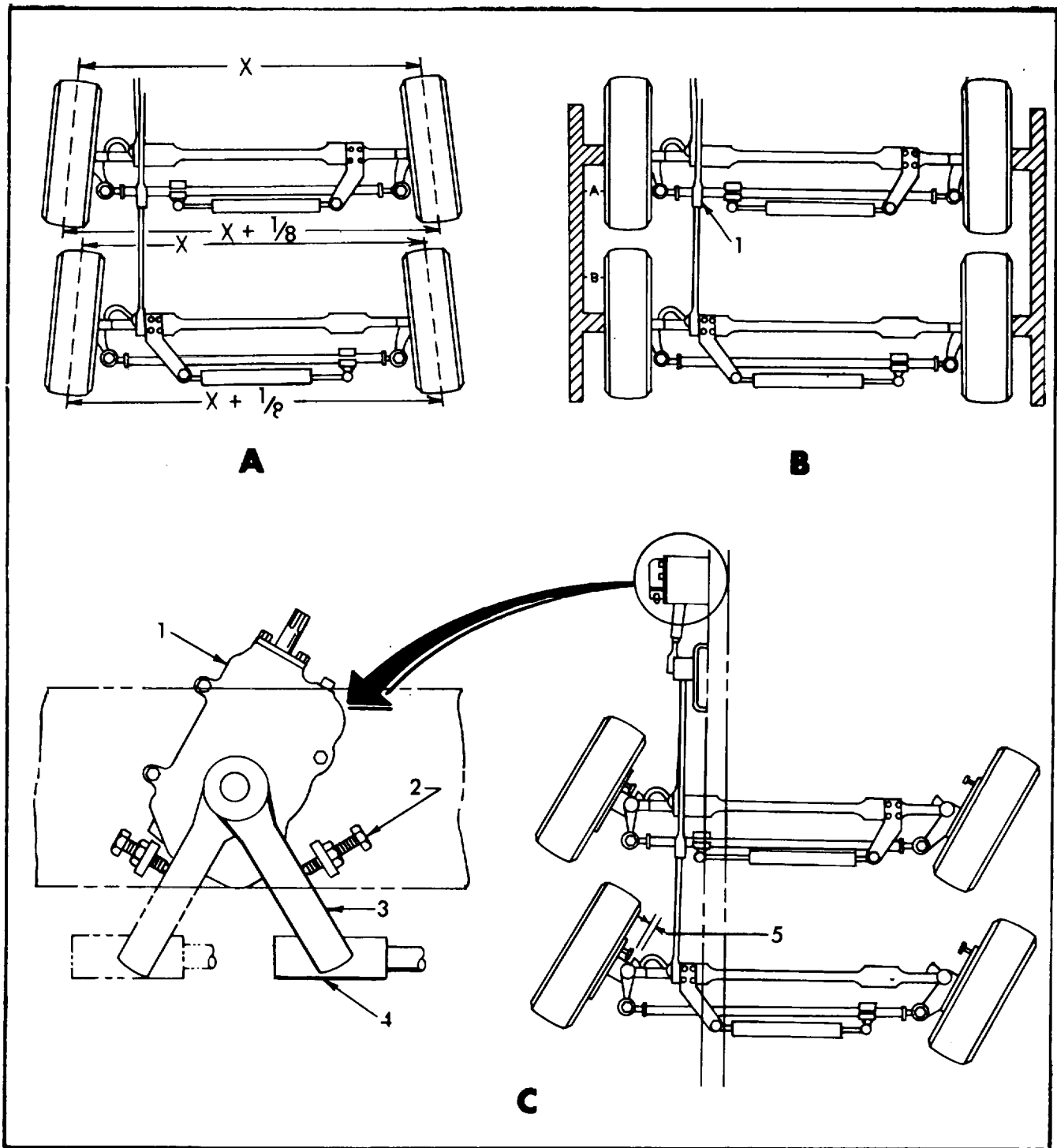

A. Toe-In Alignment

B. Axle Synchronization
1. Adjustable Drag Link

C. Axle Stop Adjustment
1. Steering Gear Box
2. Pitman Arm (Stop Adjustment)
3. Pitman Arm
4. Drag Link
5. 1/16" min. (Typical)

Illustration 4-50. Alignment.

5. Adjust the drag link between the frame mounted control arms until distances measured in (3) and (4) are the same.

AXLE STOP ADJUSTMENT. (Illus. 4-50).

1. With wheels straight, check that the Pitman Arm on the steering gear box is at the center of its range of travel. Remove and reposition on splined shaft if required.
2. Turn wheels full right until turning is stopped by either tie rod hitting the axle. Remove axle stop adjusting bolts, if necessary, to allow tie rod to hit.

NOTE

IT IS NECESSARY FOR THE TIE RODS TO HIT IN LIEU OF THE NORMAL AXLE STOPS IN ORDER TO OBTAIN FULL TURNING RADIUS.

3. Adjust the stop at the steering gear box until it contacts the Pitman Arm. Then, turn adjustment one additional turn, or as required to assure steering motion is stopped at the gear box and not by binding at the axle.
4. Turn wheels full left until stopped by the tie rod hitting and repeat (3) to adjust the other Pitman Arm adjustment at the steering gear box.
5. Check that the steering cylinders do not bottom-out when the wheels are turned either extreme right or extreme left.

TORQUE ARM ADJUSTMENT.

1. Locate the center point on the hubs of the front wheels (Within 1/16" of actual center).
2. Measure distance between the front and rear hubs on each side. These distances shall be the same.
3. Adjust front or rear torque arms as appropriate to correct.

NOTE

OF THE FOUR (4) TORQUE ARMS, TWO ARE ADJUSTABLE AND BOTH INSTALLED ON THE LEFT SIDE.

Troubleshooting.

This section of this manual should be read only after careful reading of the preceding section.

Procedure for Defining Complaints and Diagnosing Troubles.

Since power steering systems function basically alike, troubles are common regardless of how the basic units are arranged.

A thorough and orderly troubleshooting procedure will help you define power steering complaints and diagnose the troubles more surely and more quickly. Trouble shows up in various ways but by following good, thorough procedure you can eliminate many possibilities and immediately narrow down the cause of the trouble. Just like a doctor, you must know where and what the trouble is before you can correct it.

As a service man you will usually be confronted with complaints in three general areas:

1. Hard steering.
2. External leakage.
3. Undesired steering actions other than hard steering. (Shimmy, wander, over-steer, etc.).

This manual will not give detailed instructions on how to make repairs and adjustments. Use your regular service manuals for repairs and adjustments.

In troubleshooting complaints on hydraulic power steering, avoid guess work and try to make definite determinations. Make a thorough diagnosis first, that is, define the complaint as thoroughly as possible.

Diagnosis requires observing symptoms and making tests or checks to establish the cause of the trouble. Try to visualize what is occurring. For certain trouble certain symptoms should be looked for.

General Diagnosis.

The first step is to get a good account or description of the trouble or complaint from the driver. Ask the driver:

1. How does the steering act?
2. Does it act this way all the time?
3. Does it occur on only one direction (right or left turn or straight ahead)?
4. Under what conditions does it usually occur?
5. Is it accompanied by an unusual noise?

Since verbal description and interpretation can vary widely it is better to have the driver demonstrate exactly what he is complaining about. If you are still unable to define the complaint, ask him to accompany you and drive the vehicle yourself.

Perform actions in which the driver said trouble occurred. Try other steering action, too, to give you a complete and accurate definition of the trouble. You may want to try these:

1. Turn steering wheel while standing or moving slowly. (Not standing with vehicle loaded--hydraulic power may not be sufficient).
2. Steer on both directions while moving.
3. Turn steering wheel rapidly one or two turns--in both directions.
4. Observe action when traveling straight ahead.

This should give you a good understanding of the complaint.

The next step is to determine the cause of the trouble and how to remedy it.

General Inspection.

For common symptoms of trouble, make a general inspection of the system and check for conditions such as:

1. Low oil supply in reservoir.

2. Air in oil circuit. (Bubbles, foaming).
3. Loose belt, or glazed condition of belt.
4. Linkage binding or loose (sockets and connections).
5. Tire conditions, pressure.

NOTE
LOOK FOR THE SIMPLE THINGS FIRST.

For specific diagnosis and symptoms of hard steering, external leakage, and undesired steering actions see the following pages.

Hard Steering.

Hard steering is a complaint that needs considerable attention because there are numerous symptoms and causes.

Hard steering simply means the driver is not getting hydraulic power assistance that he normally should expect; however, there may be causes where the driver is expecting easier steering than the system was designed to produce.

Hard steering certainly can be demonstrated. Therefore, make sure whether or not hard steering exists.

It first should be proved to be actually hard steering before doing any troubleshooting for it.

Hard steering with a power steering system means either

1. The hydraulic power section is not creating sufficient steering force.
2. Or, the driver must overcome excessive friction (binding) in the mechanical section to actuate the control valve to apply the hydraulic power.

If the hydraulic section is not creating sufficient force, it may be because:

1. It does not develop maximum pressure.
2. Too much friction (binding) in the system beyond the point of power application (the valve) must be overcome by the power force.
3. The front end weight is excessive, the pressure is low, etc.

Briefly, the causes of hard steering may be due to hydraulic or mechanical trouble, or both, and outside factors such as excessive front end weight, etc.

The more common causes of hard steering are:

1. Pump belt slipping or broken.
2. Fluid level low.
3. Lack of sufficient oil pressure.
4. Lack of sufficient oil flow.
5. Air in oil circuit.
6. Low tire pressure.
7. Binding friction in the system (somewhere between the steering wheel and front wheels).

- a. Linkage (bent, loose or tight connections).
- b. Steering knuckles, spindles, pins and bushings.
- c. Lack of lubrication (linkage, steering gear, spindles).
- d. Steering gear column (misaligned).
- e. Steering gear adjustment (too tight).

Hard Steering Occurrences and Causes.

While Parking.

1. Belt Slippage.
2. Lack of sufficient hydraulic pressure.
3. Lack of sufficient oil flow.
4. Low tire pressure.
5. Too much friction in system (bind, lack of lubrication).
6. Overload on front wheels.

Existing All The Time. (While driving as well as while parking).

Causes are the same as while parking, but more severe.

Occurring Only Part of The Time.

1. Belt slippage.
2. Lack of hydraulic pressure.
3. Air in circuit (interferes with constant pressure and oil flow).
4. Loose or tight linkage connections.
5. Improper steering gear adjustment (shim pack on lever shaft). i.
6. Changes in load, tires, road surface, temperature of oil.
7. Parts shifting on their mountings to new locations, cab shift, binds.

Noticeable When Trying to Steer Fast.

Lack of sufficient oil flow for the speed of steering attempted (low engine rpm or belt slippage could be the cause).

Occurring In One Direction--Right or Left.

1. Bent cylinder piston rod.
2. Bind in mechanical section.
3. Mechanical interference preventing valve spool travel in one direction (such as jacket tube ends interfering with axial movement of wheel tube - at steering wheel upper end and at adjusting nut lower end - if valve is integral with steering gear).
4. Off-center adjustment of valve IF the control valve is Ross HP70 type. (Normal spool travels the same in each direction).

Noticeable At Certain Steering Wheel Positions.

Mechanical binding. May be in steering gear adjustment or elsewhere in linkage.

"Lumpy" Feeling. (Momentary spots of hard steering--not smooth).

1. Indicates a delay in power application. (Can be caused by excessive free play in mechanical parts).
2. Air in the oil (aeration) is the first thing to suspect.
3. Loose joints or linkage connections.
4. Lack of sufficient oil flow.
5. Low oil supply.

"Jerks" or "Surges" in Steering Action.

1. Loose belt (slipping intermittently).
2. Insufficient oil flow.

Accompanied by Abnormal Noises (Growl).

1. Air in the circuit.
2. Mechanical trouble in pump.
3. Low oil supply.

Other Causes of Hard Steering.

1. Valve spool sticking.
2. Valve out of adjustment.
3. Valve loose on mounting.
4. Bind in power cylinder (bent rod, broken piston or piston rings).
5. Lack of lubricant in valve actuator unit.
6. Steering wheel tube bent or sprung.
7. Bind in wheel tube bearing caused by tight clamp over bearing.

Hard Steering Remedies.

Belt Slippage.

1. Belt squeal is evidence of belt slippage.
2. Belt may be so loose that the pump output is very low.
3. Belt may be only semi-loose and only fails to turn pump when there is a heavy steering demand for hydraulic force. (Belt and pump pulley can often be seen to stop momentarily, when someone steers).
4. A belt in good condition and properly tensioned can be made to slip if the engine is accelerated rapidly while steering pressure is maintained. This action very likely hastens belt stretching and glazing.
5. Belt glazing can cause slippage. An anti-glaze application may be helpful or slightly roughen pulley belt groove.
6. The remedy may be a replacement of the belt followed by regular checking of belt tension.

Lack of Sufficient Hydraulic Pressure.

Do not trust the pressure the pump is producing unless you check the pressure with a gage.

First make sure the oil supply in the reservoir is not low.

Install a pressure gage in the line from the pump to the control valve.

CAUTION

THE GAGE AND PIPE MUST BE OF SUCH CONSTRUCTION THAT THEY WILL SAFELY WITHSTAND THE MAXIMUM PRESSURE THE PUMP CAN PRODUCE.

DO NOT DISCONNECT ANY HOSE CONNECTIONS UNTIL YOU HAVE THOROUGHLY CLEANED OFF ALL DIRT AND PROMPTLY PLUG THE PORT HOLES TO PREVENT DIRT FROM ENTERING.

With engine running at recommended idle, watch pressure developed as someone tries to steer standing still, first in one direction and then in the other.

Consult your service manual for the specified pump relief pressure, maximum.

If the maximum relief valve pressure is reached before reaching the end of piston rod travel, it is certain the pump is developing full hydraulic pressure, also that the control valve is functioning properly and pressurizing the power cylinder; therefore, the trouble is not in the hydraulic circuit. Check the other causes of hard steering which are listed. If, however, the maximum relief valve pressure is not reached and steering is hard, the system is not developing full power. This may be due to malfunctioning of the pump, valve, or cylinder. Determine which is at fault.

First check the pump. Install a shut-off valve in the pump-to-valve outlet line and locate it next to the pressure gage and between it and the valve.

CAUTION

THE SHUT-OFF VALVE MUST BE A HIGH PRESSURE TYPE TO WITHSTAND THE MAXIMUM PRESSURE THE PUMP CAN PRODUCE. AN ORDINARY PLUMBING VALVE SHOULD NOT BE USED.

With the shut-off valve open there is no restriction of flow from the pump.

Close the shut-off valve to test the ability of the pump to produce maximum pressure.

With the engine running at recommended idle speed, gradually close the shut-off valve.

CAUTION

DO NOT LEAVE SHUT-OFF VALVE CLOSED FOR MORE THAN 15 SECONDS. YOU MAY CAUSE QUICK HEATING OF OIL TO A HIGH DEGREE WHICH CAN CAUSE DAMAGE TO THE PUMP, OIL SEALS, HOSES, AND FILTER IN RESERVOIR.

If the gage shows the specified maximum pressure, the pump is producing the required pressure. If not, it may be due to a loose belt, or the pressure relief valve may be sticking open, or the pump may be in need of repairs. If the belt is not loose or glazed, disassemble the pump and inspect. See pump inspection.

When it is certain the pump is producing the required maximum pressure, next test the valve for pressurizing the cylinder. Disconnect one of the hoses at one of the cylinder ports and cap the end of the hose and plug to the cylinder port, but first clean off the dirt and make sure no dirt gets into the port holes.

Have shut-off valve open.

To test the pressure in both hoses connecting the valve to the cylinder, apply steering effort at the steering wheel.

With engine running at recommended idle speed, watch pressure as someone tries to steer in both directions while standing still.

Remember not to hold at maximum relief pressure very long. The pump can be damaged by overheating.

If maximum pressure is not attained, this condition indicates there is internal valve leakage past the restricting control edges of the valve spool or severe external leakage past the seals. The valve should be disassembled and inspected.

When a valve has been scored or seized it should be replaced. Polishing of much extent will destroy the very close fit necessary between the spool and the body. A valve spool must move freely and without sticking to operate properly. Dirt, burrs, etc., cannot be tolerated in a valve.

If the valve tests okay, there may be internal leakage or bind in the power cylinder or binding in the steering system, or insufficient oil flow.

The cylinder should be disassembled and inspected. Look for scored wall, broken piston ring, bent or scored piston rod and binding by the linkage.

Insufficient Oil Flow.

In most systems a flow in excess of just maintaining pressure is needed for desired speed of steering. If it is possible to steer slowly with enough hydraulic power to steer with ease, but a lack of power and hard steering is experienced when trying to steer faster, the problem may be one of insufficient oil flow.

Common Causes are:

1. Fitting leaks-at seats, threads, seals.
2. Hose leaks-worn or burst, bad joints, pin holes.
3. O-ring seals-worn, cut damaged, split, flats, taken set, dirt under seal, cooked by excessive oil temperature. (O-rings should be soft and pliable).
4. Reservoir spilling--may be too full, filter out of place, filter charred, oil may be overheated.

Check filter. Swinging dipstick may have rubbed opening in the filter elements which allows unbaffled stream of oil to shoot directly at the filler cap and out the breather. A swinging dipstick may loosen the rivet which holds the vent baffle and dipstick in the cap. In time, the rivet, baffle and dipstick may fall into the reservoir leaving a hole in the cap out of which oil can readily spill. As oil is sprayed out of the reservoir, the level drops sufficiently to allow the outlet to pump to be only partially covered as the oil slushes around. This produces aeration and frothing which forces more oil out of the cap.

The filter must be replaced as frequently as necessary to be sure it is doing its function as a filter of the oil.

Be sure the spring is staying in place and holding down the filter in its proper position.

Undesired Steering Actions Other Than Hard Steering.

Wander.

This is abnormal tendency to stray away from course set by driver.

Common causes:

1. Incorrect front end alignment.
2. Broken Spring.
3. Tight steering gear or linkage.
4. Loose spring shackles.
5. Unequal tire pressure.

Drift.

This is tendency to self steer toward right or left (pulls to one side) on a flat road with no crown or cross wind.

Common causes:

1. Dragging' brake.
2. Tight or dry wheel bearing.
3. Unequal tire pressure.
4. Incorrect front end alignment.
5. Steering control valve not centering. $\frac{1}{4}$
6. Bent frame.

Oversteer.

This is tendency to get more steering action than required. Some call it "drive".

Probable causes:

1. Excessive friction in steering system.
2. Steering control valve not centering.

Shimmy.

This refers to front wheels vibrating wildly and without control. Sometimes it occurs only at certain speeds or after striking a hard bump. (System chatter sometimes is started by front wheel shimmy).

Common causes:

1. Low speed shimmy.
 - a. incorrect front end alignment.
 - b. Loose linkage connections.
 - c. Loose wheel bearings.
 - d. Worn knuckle pins or bushings.
 - e. Weak or broken springs.

2. High speed shimmy.
 - a. Unequal tire pressure.
 - b. Wheels or tires eccentric or out of balance.
 - c. Badly and unevenly worn tires.
 - d. Any of the causes for low speed shimmy.

NOTE

DRIVER HABITS CAN INFLUENCE THE COMPLAINTS. THESE COMPLAINTS, EXCEPT FOR SHIMMY, ARE OFTEN IDENTIFIED ERRONEOUSLY, ONE FOR THE OTHER. LOOK FOR THE SAME THINGS WHICH CAUSE THE SAME TROUBLES WITH MANUAL STEERING.

System Chatter.

System chatter is sometimes induced by front wheel shimmy.

When chatter is a complaint, first make sure the system is stable by checking every connecting part of the steering system for correct adjustment and tightness and no lash. (Refer to loose or too tight linkage connections).

Check for front end stability, particularly if shimmy also occurs. The front end must be as stable as with manual steering, or more so. When system and front end are stable, and chatter persists, replacement of control valve may effect sufficient changes to correct the condition.

Recovery.

Front wheels usually return after a turn to the straight ahead position. This is called recovery.

NOTE

ON SOME POWER STEERING INSTALLATIONS, THE RECOVERY MAY BE SLOWER THAN FOR MANUAL STEERING.

In a power steering system, any friction that tends to keep the valve spool from returning to center, or friction that resists the return of the parts back to straight ahead can stop recovery unless manually helped by driver.

Eliminate friction and binding in order to improve recovery.

1. Tight ball sockets and other linkage connections.
2. Bent piston rod, broken piston or rings.
3. Tight knuckle pins, bushings.
4. Bind in wheel tube or wheel tube bearing.
5. Spool in valve sticking (not centering).
6. Steering gear adjusted too tight.

Insufficient caster can be cause of lack of recovery.

Air in Oil Circuit.

Air in the circuit can be due to low oil supply in the reservoir which will cause pump to suck air in with the oil.

It can be due to air leaks into the circuit elsewhere.

A leaky pump shaft seal can allow air to enter the system.

If installation has "separate reservoir"--look for "kinked" intake hose. This will cause excessive vacuum pull on pump intake seal.

For bleeding the air from the oil, see bleeding instructions.

If the air cannot be bled out, the cause of the air in the circuit must be determined and corrected.

Filling and Air Bleeding Procedure for Power Steering Systems.

Most power steering systems today must in essence be self-bleeding of air, provided sufficient oil is available in the system so that the air may be replaced by oil without further air entering the circuit. Some systems in use will eliminate air much more rapidly than others with no special precautions or aid. The following suggestions are intended to expedite the filling and air bleeding of the circuit.

1. If the system has been completely drained of oil (or the cylinder empty):
 - a. Fill reservoir "full"
 - b. Start engine but be ready to add oil as soon as the engine is started and is running at idle.
 - c. Maintain a "full" reservoir by adding oil as necessary for a minute or so without turning the steering wheel. This allows the large air bubbles in the lines, etc., to escape.
 - d. Slowly steer the wheels avoiding any abrupt changes of speed or pressure. (To be done with engine idling). Add oil as necessary to maintain a "full" oil level. Four or five turns of the road wheels (stop to stop) are generally enough to eliminate most of the air from the cylinder.

NOTE

AT THIS POINT, SOME SYSTEMS WILL HAVE ELIMINATED PRACTICALLY ALL THE AIR FROM THE SYSTEM, WHILE OTHERS WILL RETAIN A GREAT DEAL OF AIR IN THE OIL, GENERALLY IN FORM OF VERY SMALL BUBBLES AS EVIDENCED BY CLOUDY OR CREAMY APPEARANCE TO THE OIL. IF THE OIL IS CLEAR AND THE STEERING IS NORMAL, ADJUST OIL LEVEL IN RESERVOIR TO RECOMMENDED LEVEL AND SECURE THE SYSTEM. IF THERE IS ANY DOUBT OR IF THE OIL SHOWS AIR TO BE PRESENT, PROCEED AS FOLLOWS:

- e. Allow the engine to run at 1000 to 1500 rpm's for a few minutes, steering the system from stop to stop about once every minute. (Intermittent steering action allows the air to form rather large bubbles in the cylinder which are easier to expel from the oil when they reach the reservoir). Continue this procedure until the oil is clear, adjust oil to recommended level and secure system.

2. If the system has been partially drained of oil: (valve, pump, reservoir, lines but not cylinder).
 - a. Fill reservoir to recommended level.
 - b. Start engine and run at idle, adding oil to reservoir to closely maintain recommended oil level.
 - c. After several minutes, steer gently and slowly from stop to stop at first with engine idling and as the oil clears at moderately higher speeds.
 - d. When the oil clears, adjust oil to recommended level and secure system.

General Notes.

1. Loosening fitting connections at the cylinder or valve generally does not aid in air elimination from the circuit.
2. It is always desirable to have the cylinder fitting connections on top to aid in purging the air from the system. If necessary, and if possible, rotate the cylinder ports to the top for bleeding. This may be helpful in some stubborn cases.
3. When a system contains a large amount of air, as during the filling cycle, an attempt to steer will result in the pump building up pressure in the system which compresses the air. Several interesting, and sometimes disagreeable, things may result from this air in the circuit:
 - a. There will be a time delay in building up pressure due to the compression of the air and this will show up as a "hump" or "lump" when rapidly changing steering directions.
 - b. Rapid steering action results in pressure surges and may cause overflow of the oil to spout from the reservoir in geyser fashion.
 - c. If the pump is stopped, oil may also gush from the reservoir due to decompression of the air.
 - d. Attempts to steer with large amounts of air present may result in erratic action or "chatter".
4. In general, when filling the circuit, try to avoid churning small air bubbles into the system by keeping enough oil in the reservoir so the pump does not suck in air and pump it along with the oil. Small bubbles require the longest bleeding time.
5. If the system will not bleed itself and the oil remains aerated, the suction line from the pump may be the cause of the trouble due to a leak, (broken, cracked line, loose fittings, etc.).
6. Always fill the reservoir to the level recommended.

Pump Inspection.

In some pumps the pressure relief valve and the flow control valve are separate, and in some, these valves are in a single unit. These valves must be free of dirt and stickiness. Check for leaky pump shaft seal (causes oil aeration).

A hydraulic pump requires finely machined surfaces and closely fitted mating parts to maintain sealing for pumping.

Check for scoring or damage to teeth, rotor and vanes. Check clearances.

Follow service manual for the specific make and model of pump being serviced.

Clean Work Conditions.

If it is necessary to disassemble any of the component parts, make sure that a clean work bench or table is used (a piece of wrapping paper makes an excellent clean disposable top).

Outside dirt should be cleaned off before disconnecting hoses. Port holes should be plugged immediately after disconnecting hoses and before removing from the vehicle.

Finish cleaning off outside dirt before placing on work bench--especially the pump, valve, cylinder.

Parts should be cleaned in clear, clean solvent and blown dry with clean air. Keep each part separate to avoid nicks, burrs. Avoid wiping valve and pump parts with cloth since lint may actually cause the sticking of closely fitted parts.

NOTE

NEVER STEAM CLEAN HYDRAULIC STEERING ASSEMBLIES.

Do not force or abuse closely fitted parts--damage is probable.

Steer Gear.

Ball Thrust Bearing on Cam.

ADJUSTMENT.

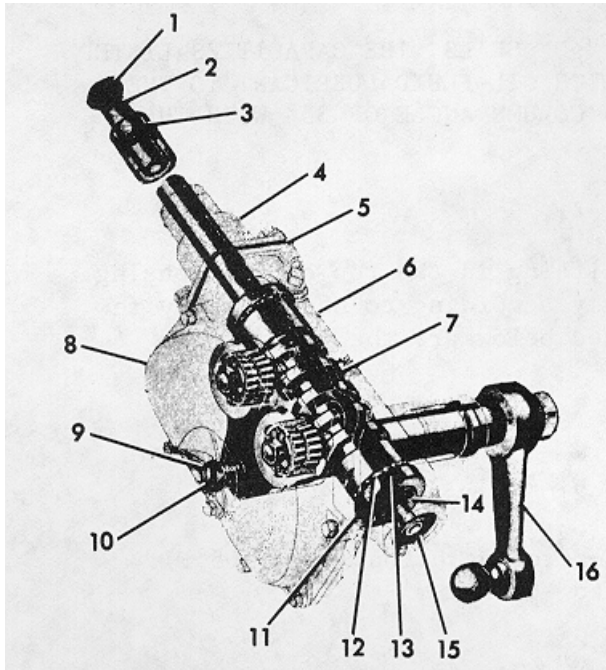

1. Wheel Tube
2. Jacket Tube Gearing
3. Jacket Tube
4. Upper Cover
5. Adjusting Shims
6. Housing
7. Cam
8. Side Cover
9. Lock Nut
10. Adjusting Screw
11. Ball Cup
12. Balls
13. Cone
14. Retaining Ring
15. End Cover and Oil Seal Tube
16. Steering Arm and Ball Assembly

When making adjustments free the steering gear of all load, preferable by disconnecting the drag link from the steering arm, and loosen the instrument board bracket clamp on steering gear jacket tube.

If the ball thrust bearings on the cam must be adjusted, make this adjustment before making the side adjustment.

1. Adjust to a barely perceptible drag but allow the steering wheel to turn freely (with the thumb and forefinger lightly gripping the rim). Before making this adjustment loosen the housing side cover adjusting screw (9, 10) to free the studs in the cam groove. To adjust, unscrew the four cap screws and move up the housing upper cover (4) to permit removal of shims (5). Shims are of .002 in., .003 in., and .010 in. thickness. Clip and remove a thin shim or more as required. Tighten all four capscrews. Draw down tight. Test adjustment and if necessary remove or replace shims until adjustment is correct (3 to 8 inch pounds rolling torque).

- a. Assembly of Replaceable Cam Bearing Unit. Use extreme care to assure that cam bearing O.D., thrust faces for locating cones, and cones are clean, free of nicks and burrs. (The two cones must seat flat).

Proper assembly consists of: cone (13) (against cam), balls (12), ball cup (11), and retaining ring (14).

LUBRICATION.

The steering gear housing should be kept full of lubricant. Lubricate through the uppermost filler hole in top of steering gear housing.

CAUTION

AVOID HIGH PRESSURE FILLING, TO PREVENT "BLOWOUT" OF SEALS. THE CAPACITIES LISTED BELOW ARE BASED ON STANDARD GEAR MODELS FILLED WITH OIL-FLUID LUBRICANT TO THE TOP OF FILLER HOLE WHEN THE GEAR IS MOUNTED AT A COLUMN ANGLE OF 350 WITH THE HORIZONTAL.

The Steering Gear capacity is 4.25 lbs.

Lubricate through the pipe plug filler hole or fitting in the top of the housing. Keep housing full by adding lubricant periodically according to usage--every few thousand miles or at least spring and fall. Listed below are the recommended lubricants:

1. Cam and Lever Steering Gears
 - A. S.A.E. 90 per Ross Specification 045165
 - B. S.A.E. 90 per Military Specification MIL-L-2105B
Grease per Ross Specification 045088
Military specification MIL-L-1032A for sub-zero operation (0° to -65°F).
Mobil fluid 300 for sub-zero operation(0° to -65°F).
2. Hydraulic Section
 - A. Automatic transmission fluid
 1. Type "A" suffix "A"
 2. Type "F"
 3. Dexron

Aniline Point.

The above oils should have an aniline point between 175°-225° (test method ASTM Test No. D611). The aniline point affects the stability (swell or shrinkage of the oil resistance compound in oil seals).

Non-Corrosive Lubricants and Hydraulic Oils.

The above lubricants and hydraulic oils are to be of a non-corrosive type, such that continued exposure to water vapor will not have a detrimental corrosive effect on any steering or hydraulic motor components.

NOTE

LUBRICATE BALLS, AFTER ASSEMBLY, WITH LIGHT OIL.

Minimum Backlash of Typical Studs in Cam Groove.

ADJUSTMENT.

Adjust so that a very slight drag is felt through the mid-position when turning the steering wheel slowly from one extreme position to the other. Backlash of studs in the groove shows up as backlash at steering wheel and at ball on steering arm.

The groove is purposely cut shallower, therefore narrower, in the mid-position angle of travel of each stud (see illustration) to provide close adjustment where usually the straight ahead driving action takes place. It also makes this close adjustment possible after normal wear occurs.

Therefore, adjust through the mid-position. Do not adjust in position off mid-position as backlash at these points is normal and not objectionable.

To adjust, tighten side cover adjusting screw (10) until adjustment is correct and tighten the locknut (9) to hold it. Then give the gear a final test.

Secure the gear at all points loosened prior to making the adjustment. Also check tightness of mounting bracket bolts and nuts, and of steering arm on lever shaft and the nut lockwasher. With all support brackets clamped tight, turn steering wheel to see if any binding exist. If so, the column is probably out of alignment and need correcting. (Refer to Column Alignment).

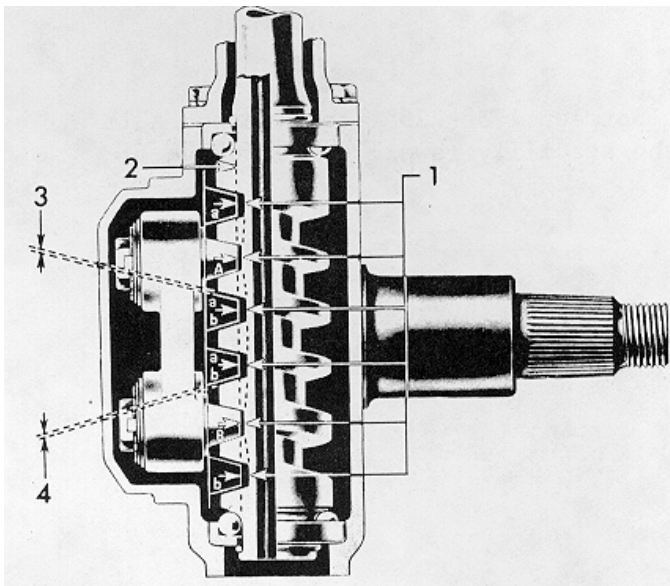

NOTES

Gear (Studs A & B) shown at Mid-Position of Travel.

A shows various Positions of Stud A on Turns.

B shows various Positions of Stud B on Turns.

Adjust through the Mid-Position.

1. Bottom of Groove Note Variation Shallower lower at A & B.
2. Path of Studs
3. Permissible Lash in Positions
4. Off Mid-Position

LUBRICATION.

The steering gear housing should be kept full of lubricant. Lubricate through the uppermost filler hole in top of steering gear housing.

CAUTION

AVOID HIGH PRESSURE FILLING, TO PREVENT "BLOWOUT" OF SEALS. THE CAPACITIES LISTED BELOW ARE BASED ON STANDARD GEAR MODELS FILLED WITH OIL-FLUID LUBRICANT TO THE TOP OF FILLER HOLE WHEN THE GEAR IS MOUNTED AT A COLUMN ANGLE OF 350 WITH THE HORIZONTAL.

The Steering Gear capacity is 4.25 lbs.

Lubricate through the pipe plug filler hole or fitting in the top of the housing. Keep housing full by adding lubricant periodically according to usage--every few thousand miles or at least spring and fall. Listed below are the recommended lubricants:

1. Cam and Lever Steering Gears
 - A. S.A.E. 90 per Ross Specification 045165
 - B. S.A.E. 90 per Military Specification MIL-L-2105B
Grease per Ross Specification 045088

Military specification MIL-L-1032A for sub-zero operation (0° to -65°F).

Mobil fluid 300 for sub-zero operation (0° to -65°F).

2. Hydraulic Section
 - A. Automatic transmission fluid
 1. Type "A" suffix "A"
 2. Type "F"
 3. Dexron

Aniline Point.

The above oils should have an aniline point between 175°-225° (test method ASTM Test No. D611). The aniline point affects the stability (swell or shrinkage of the oil resistance compound in oil seals).

Non-Corrosive Lubricants and Hydraulic Oils.

The above lubricants and hydraulic oils are to be of a non-corrosive type, such that continued exposure to water vapor will not have a detrimental corrosive effect on any steering or hydraulic motor components.

POWER STEERING SYSTEM.

Hydraulic Pump.

REMOVAL. (Illus. 4-51).

Removal of the pump is obvious. Therefore no removal procedures are given.

DISASSEMBLY. (Illus. 4-52).

1. Clean unit thoroughly with solvent, kerosene, or other non-corrosive cleaning fluid, which will not affect rubber components.
2. Scribe a line across the three sections of the pump to act as a guide in reassembly.
3. Remove the six hex screws (3), and two cap screws (2). Remove the key (23) from the drive shaft. (Four hex screws in "D" series).
4. Remove the front cover (5) by lightly tapping the flange with a soft metal hammer.
5. The center section (12) will remain attached to either the front cover (5) or back cover (21). Place the drive gear (13) into the unseparated sections, and while holding the center section (12), tap lightly to separate. Be careful to avoid cocking on the dowel pins (7).
6. Remove wear plate (10) and thrust plate (22).
7. Mark the front cover island next to the pressure vent hole in the heat shield (9), gasket (8), and V-seal (6) to act as a guide in reassembly. The location of this vent hole determines pump rotation.
8. Use a small diameter wire (a paper clip will do) to remove the phenolic heat shield (9), the paper compound gasket (8) and the rubber "V" seal (6). Discard these parts and replace when pump is reassembled.
9. Remove both "O" rings (11) and discard. They also should be replaced.
10. Do not remove shaft seal (1) in the front cover (5) unless it is damaged or leaking. If seal is to be replaced, use great care not to damage the seal recess or bearing. Heating cover in an oven to 250OF will reduce the press fit.
11. If flow control is defective replace as a cartridge.
12. If R/V is defective replace as complete R/V unit.

INSPECTION.

Drive and Driven Gear Assemblies.

Inspect shafts for roughness in the bearing and sealing areas. Measure for wear. Minimum acceptable .4998" in "D", .7492" in "H" and .9365" in "M". 5J surface finish maximum.

Inspect keyway, keys or splines for damage or excessive wear.

Inspect the gear end faces, outside diameter and teeth for roughness and score marks. The O.D. of the "D" gears must be 1.7140" minimum and the "M" gears 2.1047" minimum. For minimum gear widths see table

Size	"D" Series Minimum Gear Width	Size	"H" Series Minimum Gear Width	Size	"M" Series Minimum Gear Width
D05	.1875"	H20	.3624"	M06	.6883"
D07	.2770"	H25	.4531"	M07	.8605"
D09	.3463"	H31	.5663"	M09	1.0756"
D11	.4309"	H39	.7079"	M11	1.3446"
D14	.5412"	H49	.8849"	M14	1.6807"
D17	.6655"	H62	1.1072"		
D22	.8597"	H77	1.3840"		
D27	1.0562"				

Be sure snap rings are secure; break any sharp edges on the sides of the gears.

Gears and shafts are available only as assemblies. One gear assembly may be replaced separately if the other is in good condition.

Depress the seal pressurizing valve (15), (16), (17) and (18) in the driven gear assembly to be sure there is some resistance but movement is free. ("H" and "M" only).

Front Cover and Back Cover Assemblies.

If any bearing bore diameter exceeds .5015" in the "D" Series, .7518" in the "H" Series, or .9394" in the "M" Series, the cover should be discarded. Bearings are not supplied separately.

Replace the shaft seal (1) only if it shows excessive wear or cracking.

Check all internal threads for damage.

Bearings must be below the cover faces and show no signs of contact with snap rings on gear shafts.

If bearings are scored, rough, or show signs of heat discoloration, the cover assemblies should be replaced.

Center Section.

Inspect the wall of gear bore diameters for excessive wear or score marks. The center section gear bores will show signs of wear on the inlet side of the pump. A wear ridge will develop at the end of the gear bore where the thrust plate is located. This wear ridge should not exceed 1/32".

Lightly lap the faces to remove any nicks or burrs. Do not break inside edges.

Wear Plate and Thrust Plate.

Inspect bronze wear surfaces for excessive roughness or heat discoloration. If wear ridges exceed .0005", discard and replace.

General.

The following parts should be replaced at every major overhaul: Wear Plate (10), Thrust Plate (22), Fiber Heat Shield (9), Paper Gasket (8), "V" Seal (6), and O-Rings (11). The shaft seal (1) should be replaced only when necessary.

REASSEMBLY.

1. All parts must be thoroughly cleaned prior to reassembly by dipping in solvent and brushing to remove all traces of contamination. Pump should be assembled in a dirt free area.
2. Install shaft seal (1), if it was removed, in front cover with the spring loaded lip facing inward. Force seal into place, using a flat steel rod slightly smaller in diameter than the O.D. of the seal. This will permit the tool to enter the seal recess and bottom the rotary seal on the stop. (The front cover (5) must be backed up on a smooth, clean surface to prevent damaging its face).

The load to force seal into place should be applied exactly in line with the housing seal bore to prevent bending the seal steel retainer, and/or scoring the seal housing bore.

3. Install the "V" Seal (6), the gasket (8), and heat shield (9) into the front cover cavity as follows: The small vent hole through all of these parts shall be in line and positioned next to the scribe mark on the island previously made during disassembly. This position locates the vent holes on the outlet side of the pump.

The lips on the V seal shall face toward the cavity and be tucked into the groove with the aid of a dull tool to prevent damage to the rubber surface.

A small screw driver can be used.

The gasket shall be pressed firmly toward the bottom of the cavity with the thumbs so as to insure all of its perimeters are completely within the groove to avoid interference with subsequent assembly.

The heat shield shall be firmly pressed toward the bottom of the cavity with the thumbs to provide sufficient spacer for the wear plate.

4. Install o-ring (11) into the groove provided in front cover face. Oil the o-ring and stretch it slightly, if necessary, so that it will remain in its groove.
5. Install the wear plate (10) with the bronze surface against the gears and the small vent hole in line with the hole in the heat shield. Press the wear plate. The wear plate shall be sufficiently within the oval cavity so that it is axially retained.
6. Install drive gear (13) and driven gear (14) assemblies into the front cover. Apply oil to the shaft at the drive end to prevent damage to the shaft seal caused by sharp edges on the drive shaft passing through the shaft seal. An oil coated shaft, rotated slowly, will usually cause no damage to the seal. Check to see that the shaft seal lip and spring is not pushed out by the shaft.
7. Check wear plate to insure it is still seated into its oval cavity and install the center section (12) over the gears until it engages the wear plate. Center

section must be positioned so that the previously scribed lines on the housing exteriors are in line with those scribed on the front cover. The small slot located midway between the bores should align with the small vent hole in wear plate. The face containing the slot shall be in contact with the wear plate.

Then, install dowel pins (7) and add a generous amount of clean oil into the gear cavities. Rotate gears to distribute the oil.

8. Position the thrust plate (22) on top of the gears in the center section, with the bronze face toward the gears. The open side should be toward the inlet.
9. Install o-ring (11) into its back cover face groove. Oil the o-ring, the cover face, and the bearings. Install the back cover so that the scribe marks are in line with the marks on the center section and front cover.
10. The housing retaining screws shall be alternately tightened to 190-210 in. lbs. on the "D" Series, 190-210 in. lbs. on the "H" Series and 355-375 in. lbs. on the "M" Series.

Add a generous amount of clean oil into both ports to insure the pump is adequately lubricated. Rotate the drive shaft to distribute the oil and check for freedom of shaft rotation. Shaft shall be free to rotate with the help of a short wrench (100 in. lbs. maximum).

TESTING.

After pump has been reinstalled run 2-3 minutes before pressurizing. Try to apply pressure gradually for an additional five minutes, but do not pressurize for longer than 5 seconds at a time.

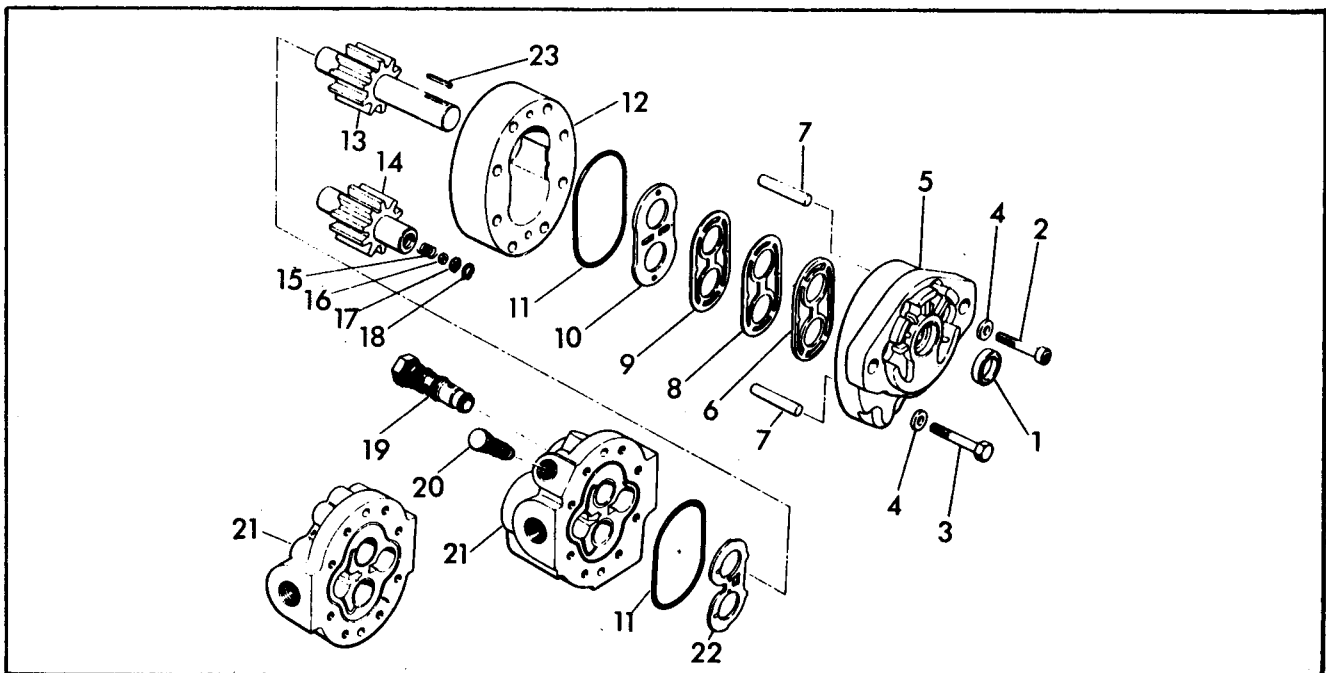

- | | | | | |
|----------------|--------------------|---------------------------|------------------------------|-----------------------------|
| 1. Shaft Seal | 7. Dowel Pins | 13. Drive Gear Assembly | 18. Snap Ring (H&M only) | 22. Thrust Plate (H&M only) |
| 2. Cap Screws | 8. Gasket | 14. Driven Gear Assembly | 19. Flow Control | 23. Key (Where Required) |
| 3. Hex Screws | 9. Heat Shield | (includes 15, 16, 17, 18) | ("H" Flow Divider Pump only) | |
| 4. Washers | 10. Wear Plate | 15. Spring (H&M only) | 20. Relief Valve | |
| 5. Front Cover | 11. "O" Rings | 16. Plate (H&M only) | ("H" Flow Divider Pump only) | |
| 6. V-Seal | 12. Center Section | 17. Ring (H&M only) | 21. Back Cover | |

Illustration 4-51. Power Pump Disassembly

TROUBLE SHOOTING.

Listed below are some troubles that may occur to the Power Steering System.

TROUBLE	PROBABLE CAUSE	REMEDY
1. Noisy pump	<ul style="list-style-type: none"> a. Low oil supply b. Oil too heavy, (i.e. viscous) c. Air leak in inlet line d. Partly blocked inlet line 	<ul style="list-style-type: none"> a. Fill reservoir. b. Change to proper viscosity. c. Check plumbing. d. Check for foreign object and/or clean.
2. Foaming oil	<ul style="list-style-type: none"> a. Pump cavitation b. Water in the oil 	<ul style="list-style-type: none"> a. See 1a, 1b, 1c, 1d. b. Check reservoir and/or heat exchange.
3. Pump or oil Overheating	<ul style="list-style-type: none"> a. Oil supply too thin b. Oil supply contaminated c. Pump cavitating d. Pump drive shaft excessively e. Pump drive shaft axially loaded by driving shaft (Prime Mover) f. System relief valve bypassing 	<ul style="list-style-type: none"> a. Drain & fill with proper viscosity oil. b. Drain, clean filter, & fill with clean oil. c. See 1a, 1b, 1c, 1d. d. Check alignment. misaligned with pump driven shaft. e. Check for clearance at ends of shafts, for shaft misalignment or worn driving keys, keyways or splines. If pulley drive check for belt alignment. f. Check relief valve setting (see 4c).
4. Low flow	<ul style="list-style-type: none"> a. Pump cavitating b. Foaming oil c. Relief valve leaks or set too low d. Speed too low e. Oil too hot 	<ul style="list-style-type: none"> a. See 1a, 1b, 1c, 1d. b. See 2a, 2b. c. Check relief valve for foreign particles. d. Check prime mover speed. e. Check temperature (see 3a, 3b, 3c, 3d, & 3e).
5. Failure to build	<ul style="list-style-type: none"> a. Defective Relief Valve pressure b. Low oil supply 	<ul style="list-style-type: none"> a. Check and reset or replace. b. Fill reservoir.

INSTALLATION.

Installation is the reverse of removal.

Steering Control Valve.

REMOVAL. (Illus. 4-13).

Removal of the Control Valve is obvious. Therefore no removal procedures are given.

DISASSEMBLY.

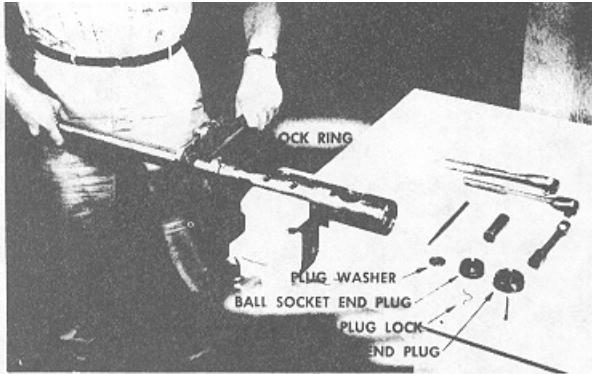

1. To disconnect the valve, remove the plug lock and end plug. Remove the ball socket end plug lock and the socket end plug. The valve can now be removed from the steering arm of the vehicle. Disconnect the other end of the drag link from the steering arm. Hold the valve in a vise for disassembly. Clamp only in the center of the housing as this is the heavier section. The lock ring has been crimped into a notch in the drag link adapter. Straighten the ring, then remove the adapter with a pipe wrench.

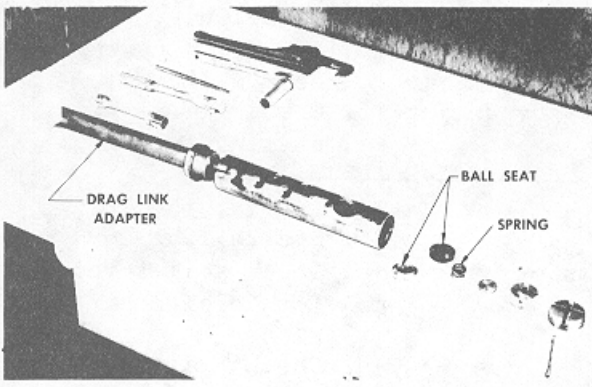

2. The ball socket must be disassembled before the body can be removed from the housing. Place a punch into oil passage hole in the piston to hold the piston from turning. Remove the nut from the ball socket end of the piston. This requires a 3/4" hex socket and a 4" extension. Remove the ball socket and ball socket bearing.

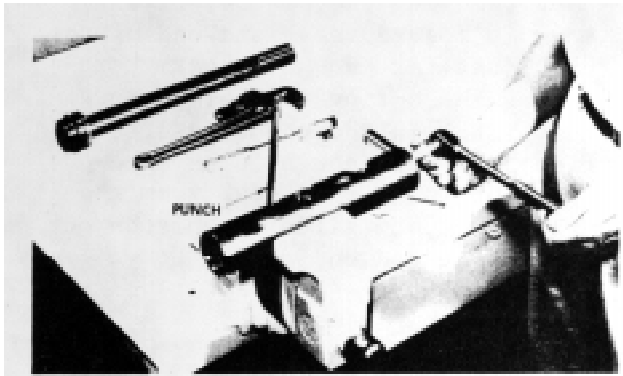

3. The valve body assembly can now be removed from the housing. The housing contains a snap ring that provides a stop for the valve body. It is not necessary to remove this snap ring.

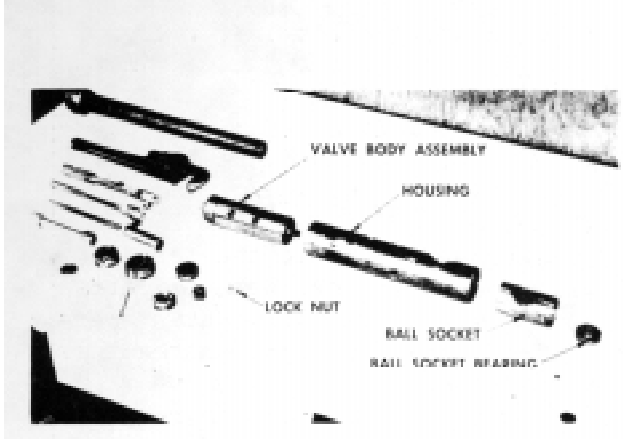

4. To disassemble the valve body and piston, hold it in a vise. Place a punch in the oil passage hole in the piston to keep it from turning and remove the nut from the gland end of the piston with a 3/4" hex socket. Remove the washer. Hold the piston in the body and remove the gland, the two reaction rings and the spacer. Do not try to remove the gland and piston together as the o-ring seals on the piston will be damaged in doing so.

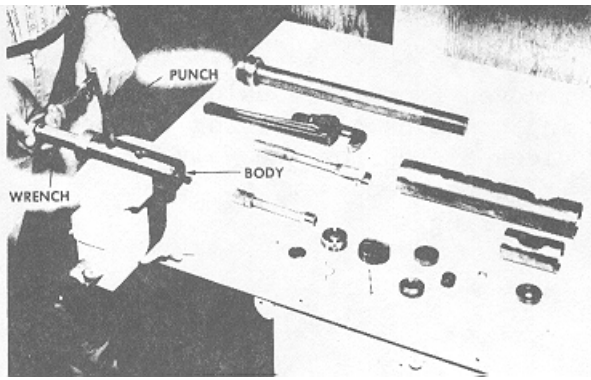

5. When removing the piston, first move it toward the gland end of the body just far enough to permit removing the o-ring seal. Then move the piston in the opposite direction just far enough to permit removing the o-ring seal from the other end. Now slide the piston out from the gland end of the body.

Inspection and Reconditioning.

Clean and wash all parts thoroughly in solvent or kerosene. Handle the parts separately and carefully to avoid damaging the finished surfaces. Wear of parts such as piston, reaction rings and valve body is negligible as these parts operate in circulating oil. It is impractical for a field service shop to attempt to measure wear. Therefore a careful visual inspection of all parts is most important.

Examine the surfaces of the piston and the bore of the body for scoring or damage that may have been caused by foreign matter in the fluid. Parts that are badly scored and scratched should be replaced. Light scratches can be removed by polishing with fine crocus cloth. Do not "round-off" or chamfer the port edges of the piston or body. These edges should remain sharp to insure proper sealing. If they are broken the result would be excessive leakage and reduced hydraulic power.

O-ring seals should be examined carefully for damage. If surface is rough or cut it should be replaced.

REASSEMBLY.

Reassemble is opposite of disassemble.

INSTALLATION.

1. Place the ball seat in the ball socket and assemble the valve over the ball stud on the vehicle steering arm. Assemble the ball seat, spring and ball socket end plug. Tighten the end plug until it "bottoms", then back it off until the nearest set of holes in the socket line up with the slot in the end plug to permit installing the plug lock.
2. Attach the hydraulic lines to the valve ports. The front cover illustration shows the valve porting lines should be attached to the same ports from which they were originally removed.
3. When installing the valve housing end plug, particular attention should be given to positioning it properly. The plug provides a stop to limit and control the outward stroke of the valve piston. There should be 1/16 of an inch (.062) maximum gap between the end of the ball socket and the face of the end plug, when the valve piston is in a neutral and centered position.

To obtain the proper end plug position, proceed as follows:

After the power steering system is installed complete, fill the reservoir to the specified level with the type of oil recommended. Start the engine to allow the hydraulic fluid to circulate through the system. Have the front axle jacked up so the wheels clear. Turn the wheels to full right and full left a few times to allow the power cylinder and the lines to fill. Check the fluid level in the reservoir and refill if necessary.

Increase the engine speed to about 750 or 800 RPM. The pressure in the hydraulic system will automatically center the valve piston in neutral position.

Turn the housing end plug inward until there is 1/16 of an inch gap between the two end plugs. This dimension can be measured by inserting a feeler gage shim (.062 width) between the plugs through the inspection hole in the valve housing. Remove the gage and continue turning the end plug inward until the nearest set of holes in the housing line up with the slot in the end plug to permit installing the end plug lock.

The end plug lock should snap securely in place. If it has been distorted, bend the ends of it away from the circular section. This will permit the lock to fit tightly.

4. If the valve is to be installed when it is not possible to operate the engine for hydraulic power, such as described in the preceding paragraph, then the following procedure will apply to make the end plug adjustment:

Assemble the valve on the steering arm ball stud and assemble the ball socket end plug as described in the first paragraph of the installation instructions.

Move the valve so the valve piston and ball socket travel inward. Hold the valve against the stop and turn the housing end plug inward until there is 1/8 of an inch (.125) gap between it and the ball socket end plug. Insert a gage (.125 width) between the plugs through the inspection hole in the housing to check the measurement. Now remove the gage and continue turning the end plug inward until the nearest set of holes in the housing line up with the slot in the end plug to permit installing the end plug lock.

It is important that the end plug adjustment is properly made to assure that it provides for a stop when the ball socket moves outward. This eliminates the possibility of placing tension on the valve piston when the valve is actuated during steering operation.

Always provide a dust shield to cover the ball socket opening.

A lubrication fitting is provided for the valve ball socket and stud. Lubricate as regularly as vehicle chassis lubrication servicing.

Before placing the vehicle in operation, recheck all line fittings on the valve, power cylinder and pump. Check the end plug in the ball socket on the drag link and on the power cylinder rod. The end plugs should be adjusted properly. First, turn the plug in as far as possible then back it off about one-eighth of a turn to provide a minimum of clearance.

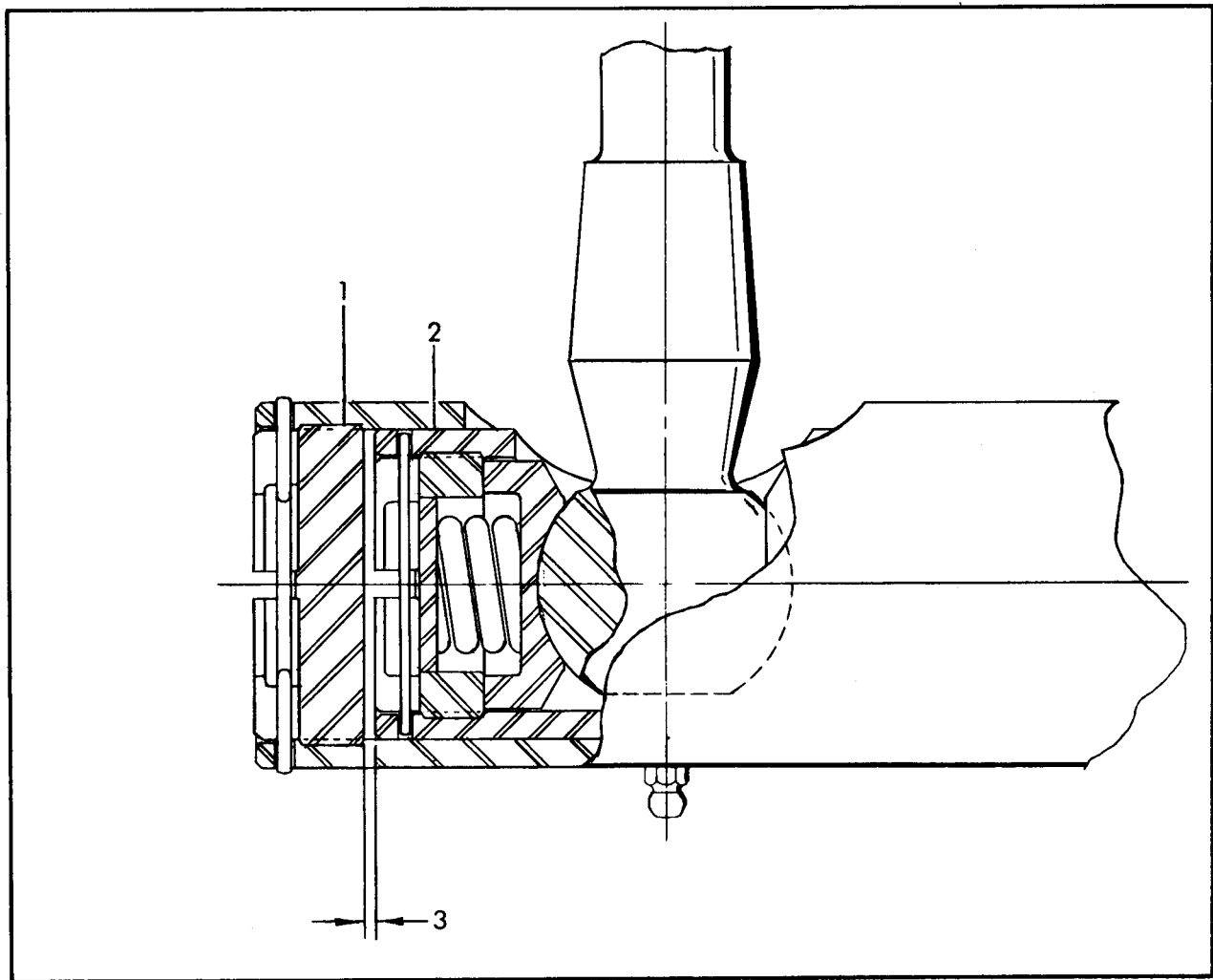

1. End Plug

2. Ball Socket

3. .060 Gap Max. Value
Piston in Neutral Position

Illustration 4-52. Steer Control Valve Adjustment

Trouble - No recovery, from turn to straight ahead.

CAUSE

1. Low pump output
2. Piston in steering valve sticking, (prevents centering)
3. Ball stud adjustment too tight
4. Steering linkage too tight
5. Insufficient wheel caster
6. Steering gear too tight (out of adjustment)

REMEDY

1. Check pump output and replace if necessary.
2. Disassemble valve and inspect for sticking.
3. Adjust for proper clearance.
4. Readjust.
5. Readjust per manufacturers specifications.
6. Readjust per manufacturers specifications.

Trouble - Excessive Lost Motion at Steering Wheel.

CAUSE

1. Loose ball socket connections or other linkage connections.
2. Excessive back-lash in steering gear
3. End plug on steering valve not properly positioned

REMEDY

1. Tighten and readjust.
2. Readjust per manufacturers specifications.
3. Make adjustment as outlined in service instructions.

Trouble - Noise.

CAUSE

1. Pump drive belt out of adjustment
2. Low oil level
3. Air in system
4. Worn pump
5. Hydraulic hose lines in direct contact with vehicle frame or sheet metal

REMEDY

1. Adjust.
2. Refill system.
3. Bleed system by loosening fitting on power cylinder to let air escape. Check all fitting connections for tightness.
4. Repair or replace.
5. Insulate lines from frame contact with rubber grommets.

Trouble - Steering Shimmy or Chatter.

CAUSE

1. Loose ball socket connections or other linkage connections.
2. Wheels out of balance
3. Excessive caster
4. Excessive back-lash in steering gear
5. Loose pump belt
6. Area of valve reaction rings too low

REMEDY

1. Tighten and readjust.
2. Balance.
3. Correct and have alignment of front end checked.
4. Readjust gear.
5. Adjust belt tension.
6. Select rings with greater area.

Cylinder.

REMOVAL. (Illus. 4-13).

Removal of the Cylinder is obvious. Therefore no removal procedures are given.

DISASSEMBLY. (Illus. 4-53).

Disassemble in accordance with the index numbers.

1. To service the cylinder, first remove the snap ring from the head.
2. Push the head into the cylinder about one-half inch or far enough to permit removal of the snap ring from cylinder tube.
3. By pulling the rod outward, the head, and piston and rod assembly can be removed as a unit. The head can now be removed from the rod.
4. The rod seal and washers can be removed from the head by taking out the retaining ring.
5. Examine the piston and piston rings for damage. These parts should be replaced if they are worn or badly scored.
6. If the piston is removed from the rod, the copper washer seal should be replaced with a new one.
7. Inspect the inner wall of the cylinder body for scoring. Light scratches on the wall can be removed by buffing with crocus cloth.
8. Examine the o-ring seal for cuts and abrasions on the outer surface that would cause leakage.
9. The rod seal assembly should be examined carefully for damage.
10. If the sealing edges of the neoprene ring are cut or worn, leakage will occur.
11. The nylon wedge ring and gland act as a rod scraper and if the edges are broken or "notched" foreign matter will enter the seal cavity.
12. Wash and clean all parts thoroughly in solvent or kerosene before reassembly.
13. Check the rear pin and universal block for wear. The pin should fit snugly when assembled in the cylinder base and universal block.

REASSEMBLY.

Lubricate all seals and parts with light oil before assembly.

Install the rings on the piston having the joints positioned opposite each other.

A standard ring compressor will be required for assembling the piston and rod assembly in the body.

Install the washers and rod seal assembly in the head and secure it with the snap ring.

Install the o-ring seal on the head.

When assembling the head into the body, move it slowly so the o-ring will not be damaged as it passes the port hole in the body.

Install the snap ring in the body. Pull the rod outward to force the head against

the snap ring.

Install the spiral lock ring on the head.

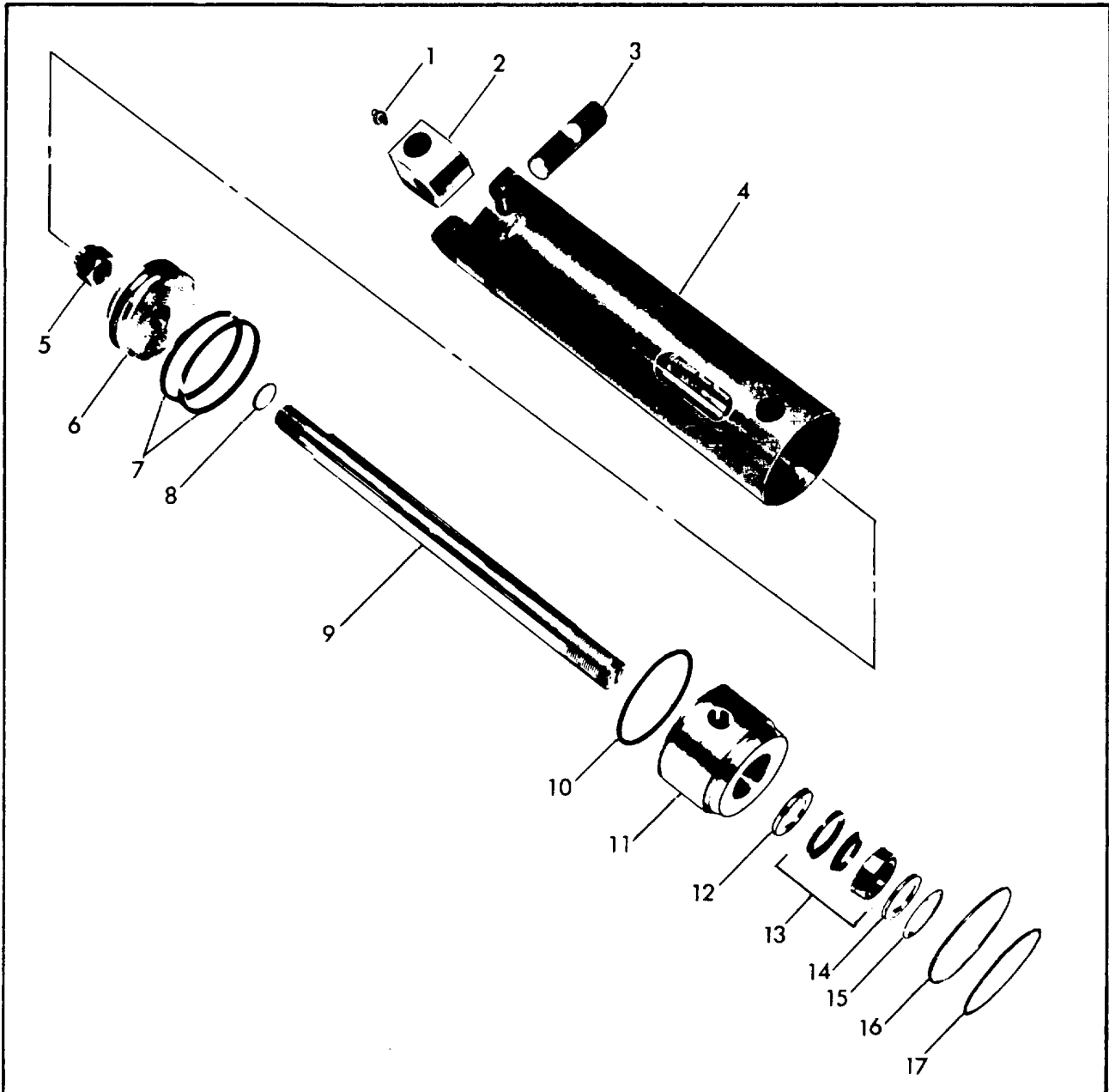

- | | | | |
|----|-----------------|-----|---------------|
| 1. | Lube Fitting | 10. | O-Ring |
| 2. | Universal Block | 11. | Cylinder Head |
| 3. | Pin | 12. | Washer |
| 4. | Body Assembly | 13. | D-W Seal |
| 5. | Nut | 14. | Washer |
| 6. | Piston | 15. | Snap Ring |
| 7. | Piston Rings | 16. | Snap Ring |
| 8. | Copper Washer | 17. | Snap Ring |
| 9. | Cylinder Rod | | |

Illustration 4-53. Steer Cylinder Disassembly.

Brakes. (Illus. 4-54 and 4-55).

MAINTENANCE AND TROUBLE ANALYSES.

Maintenance and trouble analysis charts for the brakes are specified in the above illustrations.

AIR SYSTEM.
Compressor.

REMOVAL. (Illus. 4-56).

Removal of the compressor is obvious. Therefore no removal procedures are given.

DISASSEMBLY. (Illus. 4-56).

1. Remove road dirt and grease from the exterior of the compressor with a cleaning solvent.
2. Before the compressor is disassembled, the following items should be marked to show their relationship when the compressor is assembled.
3. Mark both the front and rear end cover in relation to the crankcase.
4. Mark the drive end of the crankshaft in relation to the front end cover and the crankcase.

NOTE

A CONVENIENT METHOD TO INDICATE THE ABOVE RELATIONSHIPS IS TO USE A METAL SCRIBE TO MARK THE PARTS WITH NUMBERS OR LINES. DO NOT USE A MARKING METHOD THAT CAN BE WIPED OFF OR OBLITERATED DURING REBUILDING, SUCH AS CHALK. REMOVE ALL COMPRESSOR ATTACHMENTS SUCH AS GOVERNORS, AIR STRAINERS OR INLET FITTINGS, DISCHARGE FITTINGS AND PIPE PLUGS.

5. Mark the cylinder head in relation to the crankcase. Mark the base plate or base adapter in relation to the crankcase.
 1. Cylinder Head.
 - A. Remove the six cylinder head cap screws and tap the head with a soft mallet to break the gasket seal.
 - B. Remove the inlet valve springs from the head and inlet valves from their guides in the crankcase.
 - C. Remove inlet valve guides from around the inlet valve seats on the crankcase taking care not to damage seats.
 - D. Scrape off any gasket material from the cylinder head and crankcase.
 - E. Unscrew the discharge valve seats from the head and remove the discharge valves and springs.
 - F. Inspect the discharge valve seats for nicks, cracks, and excessive wear and replace if necessary.
 - G. Inspect discharge valve stops for wear and replace if excessive peening has occurred.
 - H. Determine if excessive peening has occurred, measure the discharge valve travel. Discharge valve travel must not exceed .057 inches.
 - I. Remove the discharge valve stops, support the machined surface of the cylinder head on an arbor press bed and gently press the stops from the top of the head and out the bottom.
 - J. Be sure to allow sufficient clearance for the stops between the press bed and the bottom of the cylinder head. The valve stop bores in the cylinder head must be inspected for excessive scoring. A new head body must be used if scoring is excessive.
 - K. Discard the inlet valves and springs, the discharge valves and springs and the discharge valve seats if defective.

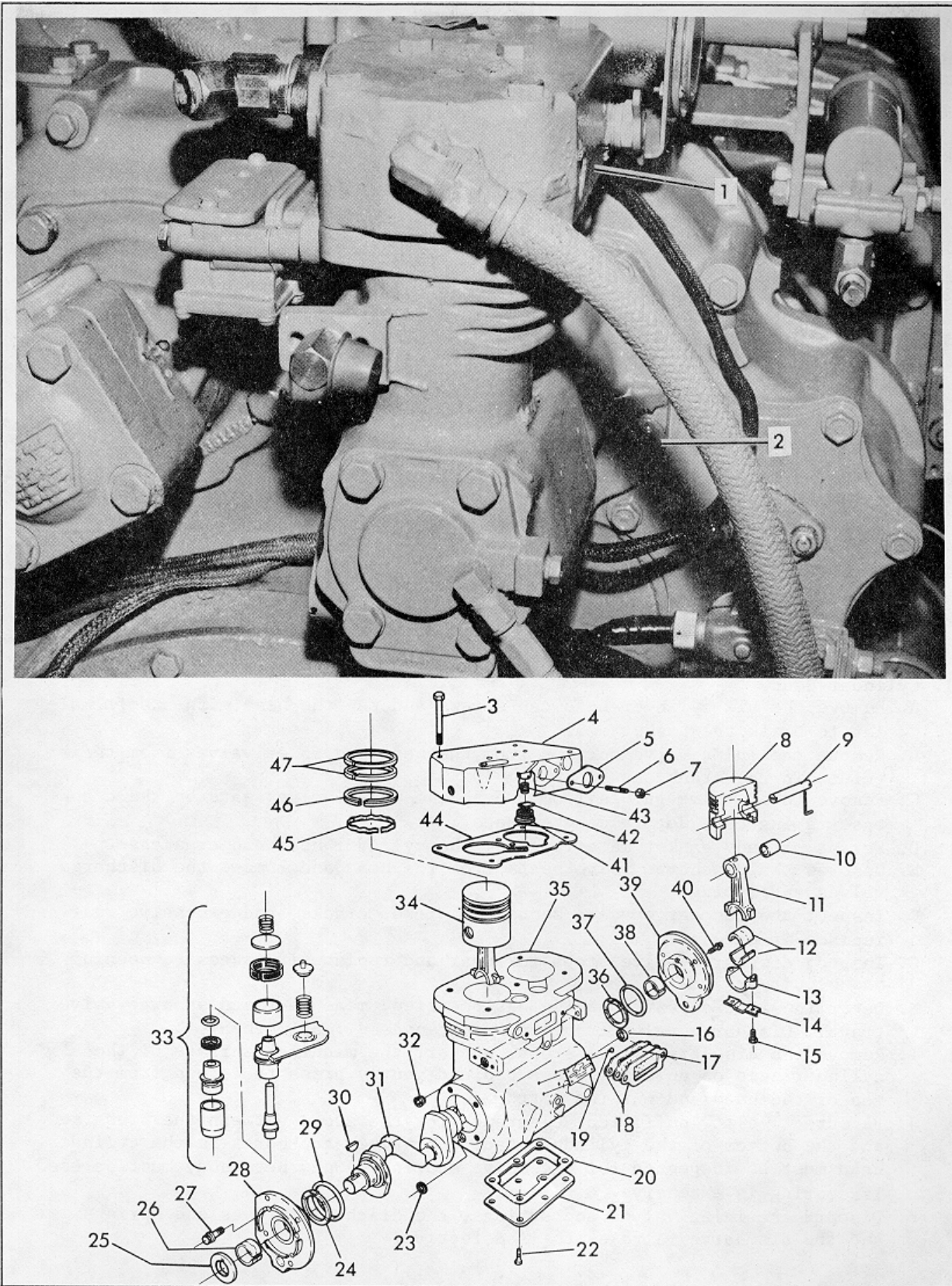

Illustration 4-56. Air Compressor Removal and Disassembly. (Sheet 1 of 2)

1. Compressor
2. Mounting Bolts
3. Bolt
4. Head
5. Gasket
6. Stud
7. Nut
- B. Piston Head
9. Wrist Pin
10. Bushing
11. Rod
12. Bushing
13. Rod Cap
14. Lockwasher
15. Bolt
16. Seal
17. Gasket
18. Gaskets
19. Rivet
20. Gasket
21. Cover Plate
22. Bolt
23. O-Ring
24. Ring
25. Seal
26. Bushing
27. Capscrew
28. End Plate
29. Seal
30. Key
31. Crankshaft
32. Plug
33. Unloader Mechanism
34. Piston
35. Block
36. Ring
37. Seal
38. Bushing
39. Mounting Plate
40. Capscrew
41. Discharge Valve
42. Valve Stop
43. Seat
44. Head Gasket
45. Piston Ring
46. Piston Ring
47. Piston Ring

Illustration 4-56. Air Compressor Removal and Disassembly. (Sheet 2 of 2)

2. Crankcase Base Plate or Adapter.
 - A. Remove the cap screws securing the base plate or base adapter. Tap with soft mallet to break the gasket seal.
 - B. Scrape off any gasket material from crankcase and plate or adapter.
3. Connecting Rod Assemblies.

NOTE

BEFORE REMOVING THE CONNECTING RODS, MARK EACH CONNECTING ROD AND ITS CAP. EACH CONNECTING ROD IS MATCHED TO ITS OWN CAP FOR PROPER BEARING FIT, AND THESE PARTS MUST NOT BE INTERCHANGED.

- A. Straighten the prongs of the connecting rod bolt lock strap and remove the bolts and bearing caps.
 - B. Push the piston with the connecting rods attached out the top of the cylinders of the crankcase.
 - C. Replace the bearing caps on their respective connecting rods.
 - D. Remove the piston rings from the pistons. If the pistons are to be removed from the connecting rods, remove the wrist pin lock wires and press the wrist pins from the pistons and connecting rods.
 - E. If the pistons are removed from the rod, inspect the bronze wrist pin bushing. Press out and replace the bushing if it is excessively worn.
 - F. Discard the piston rings and the connecting rod journal bearings. Discard the wrist pin bushings if they were removed.
4. Crankcase.
 - A. Remove the key or keys from the crankshaft and any burrs from the crankshaft where the key or keys were removed.

NOTE

THROUGH DRIVE COMPRESSORS MAY HAVE A CRANKSHAFT KEY AT BOTH ENDS.

- B. Remove the four cap screws securing front or drive-end end cover or flange adapter.
- C. Remove the end cover, taking care not to damage the crankshaft oil seal or front main bearing, if any.
- D. Remove both of the small seal rings from the crankcase, and the O-Ring from around the front end cover.
- E. Remove the four cap screws securing the rear end cover and remove the rear end cover taking care not to damage the rear main bearing, if any.
- F. Remove both of the small seal rings from the crankcase and the O-Ring from around the end cover.
- G. If the compressor has ball type main bearings, press the crankshaft and ball bearings from the crankcase, then press the ball bearings from the crankshaft.
- H. Remove the unloader spring, spring saddle, and spring seat from the inlet cavity of the crankcase, using long nose pliers.
- I. Remove the unloader plungers and guides.
- J. Cover the inlet cavity with a shop rag and apply air pressure to the governor mounting pad unloader port to blow the unloader pistons out of their bores and into the inlet cavity.

CLEANING.

All parts should be cleaned in a good commercial grade solvent and dried prior to inspection.

1. Cylinder Head.

Remove all the carbon deposits from the discharge cavities and all the rust and scale from the cooling cavities of the cylinder head body. Scrape all the foreign matter from the body surfaces and use shop air pressure to blow the dirt particles from all the cavities.

2. Crankcase.

Clean the carbon and dirt from the inlet and unloader passages. Use shop air pressure to blow the carbon and dirt deposits from the unloader passages.

3. Oil Passages.

Thoroughly clean all oil passages through the crankshaft, crankcase, end covers, and base plate or base adapter. Inspect the passages with a wire to be sure.

Blow the loosened foreign matter out with air pressure.

INSPECTION.

1. Cylinder Head Body.

Inspect the cylinder head for cracks or damage. Apply shop air pressure to one of the coolant ports with all others plugged, and check for leakage by applying a soap solution to the exterior of the body. If leakage is detected, replace the head.

2. End Covers.

Check for cracks and external damage. If the crankshaft main bearings are installed in the end cover, check for excessive wear and flat spots and replace them if necessary. If the compressor has an oil seal in the end cover, it should be replaced by pressing it out of the end cover.

3. Crankcase.

Check all crankcase surfaces for cracks and damage. On compressors where ball bearing main bearings are used the difference between the O.D. of the outer race and the I.D. of the crankcase hole should be .0000" to .0015" loose. This is to maintain the correct press fit. The crankcase must be replaced if the fit is too loose.

On compressors fitted with precision, sleeve main bearings, the difference between the O.D. of the crankshaft journal and the main bearing I.D. must not exceed .0065". If the clearance is greater than .0065", the end cover or main bearing must be replaced.

Check the unloader bore bushings to be sure they are not worn, rusted, or damaged. If these bushings are to be replaced, they can be removed by running a 1/8" pipe thread tap into the bushing, and inserting a 1/8" pipe threaded rod and pulling the bushing straight up and out. Do not use an easy-out for removing these bushings. If the inlet valve seats are worn or damaged, so they cannot be reclaimed by facing, they should be replaced. Cylinder bores which are scored or out of round by more than 0.001" or tapered more than 0.002" should be rebored or honed oversize. Oversized pistons and piston rings are available in 0.010", 0.020" and 0.030" oversizes. Cylinder bores must be smooth, straight, and round. Clearance between the cast iron pistons and cylinder bores should be between 0.002" minimum and 0.004" maximum.

4. Pistons.

Check the pistons for scores, cracks, or enlarged ring grooves; replace the pistons if any of these conditions are found. Measure each piston with a micrometer in relation to the cylinder bore diameter to be sure the diametral clearance is between 0.002" minimum and 0.004" maximum.

Check the fit of the wrist pins to the pistons and connecting rod bushings. The wrist pin should be a light press fit in the piston. If the wrist pin is a loose fit, the piston and pin assembly should be replaced. Check the fit of the wrist pin in the connecting rod bushing by rocking the piston. This clearance should not exceed .0007". Replace the wrist pin bushings if excessive clearance is found. Wrist pin bushings should be reamed to between .5314" and .5317" after being pressed into the connecting rods. Replace the used wrist pin lock wires

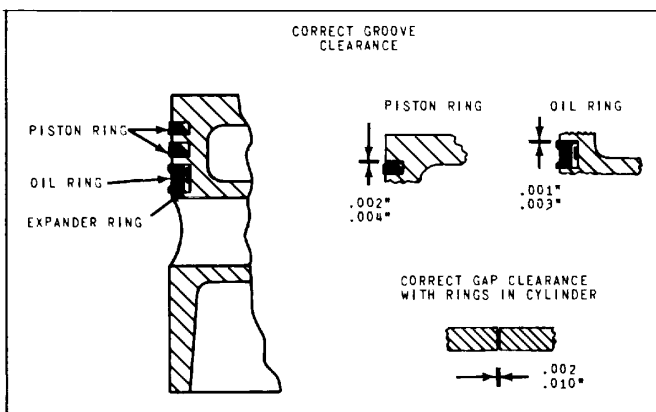

Check the fit of the piston rings in the piston ring grooves. Check the ring gap with the rings installed in the cylinder bores.

5. Crankshaft.

Check the crankshaft threads, keyways, tapered ends and all machined and ground surfaces for wear, scores, or damage. Standard crankshaft journals are 1.1250" to 1.1242" in diameter. If the crankshaft journals are excessively scored or worn or out of round the crankshaft must be replaced. Connecting rod bearing inserts are available in 0.010", 0.020" and 0.030" undersizes for compressors with reground crankshafts. Main bearing journals must be maintained so the ball bearings

are a snug fit. In crankshafts fitted with oil seal rings, the oil seal ring groove or grooves must not be worn. The ring groove walls must have a good finish and they must be square. Check to be sure the oil passages are open through the crankshaft.

6. Connecting Rod Bearings.

Used bearing inserts must be replaced. Connecting rod caps are not interchangeable. The locking slots of the connecting rod and cap should be positioned adjacent to each other. Clearance between the connecting journal and the connecting rod bearing must not be less than 0.0003" or more than 0.0021" after rebuilding.

REPAIRS.

1. Discharge Valves, Valve Stops and Seats.

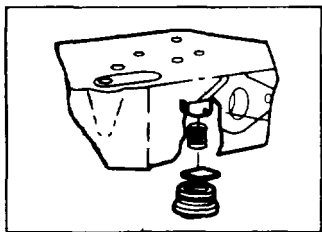

If the discharge valve seats merely show signs of slight wear, they can be dressed by using a lapping stone, grinding compound and grinding tool. If the discharge valve stops are to be replaced, an application of a sealer is required, such as "Loctite Retaining Compound #75". Be sure that the press fit between the discharge valve stop outside diameter and the valve stop bore in the cylinder head is a minimum of .0008" and a maximum of .0028". If this fit can not be maintained, a new cylinder head body must be used. Be sure to completely support the outside top of the cylinder head casting, while pressing in the replacement stops. Install the new discharge valve springs and valves. Screw in the discharge valve seats. Discharge valve travel should be between .041" to .057"

To test for leakage by the discharge valves, apply 100 pounds of air pressure through the cylinder head discharge port and apply a soap solution to the discharge valves and seats. A slight leakage in the form of soap bubbles is permissible. If excessive leakage is found, leave the air pressure applied and with the use of a fibre or hardwood dowel and a hammer, tap the discharge valves off their seats several times. This will help the valves to seat and should reduce the leakage. With the air pressure still applied at the discharge port of the cylinder head, check for leakage around the discharge valve stops exposed on the top of the cylinder head casting. No leakage is permitted.

2. Inlet Valves and Seats.

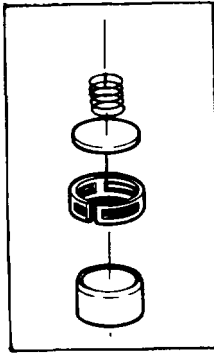

Inlet valves and springs should be replaced, if the inlet valve seats show signs of slight nicks or scratches. They can be redressed with a fine piece of emery cloth or by lapping with a lapping stone, grinding compound and grinding tool. If the seats are damaged to the extent that they cannot be reclaimed, they must be replaced. The dimension from the top of the cylinder block to the inlet valve seat should not exceed .113" nor be less than 0.101".

All torques specified in this manual are assembly torques and can be expected to fall off after assembly is accomplished. Do not retorquing after initial assembly torques fall.

To convert inch pounds of torque to foot pounds of torque, divide inch pounds by 12.

$$\frac{\text{inch pounds}}{12} = \text{foot pounds}$$

To convert foot pounds of torque to inch pounds of torque, multiply foot pounds by 12.

$$\text{foot pounds} \times 12 = \text{inch pounds}$$

1. Crankshaft.

CAUTION

ALL FLANGE MOUNTED COMPRESSORS MUST BE ASSEMBLED WITHOUT A GASKET BETWEEN THE CRANKCASE AND FLANGE ADAPTER AND SOME COMPRESSORS DO NOT REQUIRE GASKETS ON THE END COVER. INSTALL THE NEW CRANKCASE GASKETS ONLY WHERE THEY WERE REMOVED DURING DISASSEMBLY.

- A. If the compressor uses a ball type main bearing, press the ball bearing onto the correct end of the crankshaft.
- B. Position the ball bearing and the crankshaft in the crankcase, making sure the drive end of the crankshaft is positioned in the crankcase as marked before disassembly.
- C. Carefully press the crankshaft and ball bearing into the crankcase using an arbor press.
- D. In the case of compressors with a front ball bearing, place two small seal rings in the counter-sunk holes at the front of the crankcase, as well as an end cover gasket.
- E. Install the front end cover in the proper position as marked before disassembly, taking care not to damage the new oil seal.

NOTE

IN THE CASE OF COMPRESSORS WITH A REAR BALL BEARING, PLACE TWO SMALL SEAL RINGS IN THE COUNTER-SUNK AT THE REAR OF THE CRANKCASE. IN ONE CASE A GASKET IS USED AND IN ANOTHER A LARGE O-RING IS PLACED IN THE COUNTERBORE AT THE REAR OF THE CRANKCASE. THESE ARE IN ADDITION TO THE SEAL RINGS.

- F. Install the rear end cover in the proper position as marked before disassembly.

CAUTION

IN THE CASE OF COMPRESSORS WITH A SLEEVE BEARING EITHER FRONT OR REAR, PLACE THE TWO SMALL SEAL RINGS IN THE COUNTER-SUNK HOLES IN THE CRANKCASE. AN END COVER GASKET MUST NOT BE USED.

- G. Place the O-ring seal in the groove around the flange adapter or the end cover, and affix the thrust washer.
H. Install the flange adapter or end cover in the proper position as marked before disassembly, taking care not to damage the sleeve bearing.

NOTE

FOR CAST IRON FLANGE ADAPTERS, TORQUE THE FOUR 7/16" CAP SCREWS TO 38-45 FOOT POUNDS. FOR DIE CAST ALUMINUM END COVERS, TORQUE THE FOUR 7/16" CAP SCREWS TO 25-30 FOOT POUNDS. ALL END COVERS USING 5/16" CAP SCREWS OR STUD AND NUTS ARE TORQUED TO 15-18 FOOT POUNDS. FOR THROUGH DRIVE COMPRESSORS WITH A CAST IRON END COVER, TORQUE THE FOUR 7/16" CAP SCREWS TO 25-30 FOOT POUNDS.

1. Secure the flange adapter, front or rear end cover to the crankcase by tightening the four cap screws.
2. Pistons and Connecting Rods.

NOTE

IF NEW WRIST PIN BUSHINGS ARE TO BE USED, THEY SHOULD BE PRESSED INTO THE CONNECTING RODS SO THAT THE OIL HOLE IN THE BUSHING LINES UP WITH THE ONE IN THE ROD. THE NEW BUSHINGS SHOULD THEN BE REAMED OR HONED TO PROVIDE BETWEEN 0.0001" AND 0.0006" CLEARANCE ON THE WRIST PIN.

- A. Position the connecting rod in the piston and press in the wrist pin so the lockwire hole in the pin aligns with that of the piston.
- B. Install the new lockwire through piston and wrist pin and lock same by snapping the short end into the lockwire hole at the bottom of the piston.
- C. Install the piston rings in the correct location with the ring pipmarks up.
- D. Stagger the position of the ring gaps. Prelubricate the piston, piston rings, wrist pin and connecting rod bearings with clean engine oil before installing them in the compressor.
- E. Remove the connecting bolts and bearing cap from one connecting rod.
- F. Turn the crankshaft so that one of its connecting rod journals is in the downward, center position.

- G. Install the crankshaft journal bearing segments in the connecting rod and connect the rod cap.
 - H. Insert the connecting rod with piston through the top of the cylinder.
 - I. Position and attach the bearing cap to the connecting rod, making sure the bolt lock strap is positioned on the cap. Tighten the connecting rod bolts evenly and torque to 100-115 inch pounds or 8-9 foot pounds.
 - J. Bend the new lock strap prongs up against the hex head of the bolts.
 - K. Install the other connecting rod and piston in the same manner.
3. Unloader.

NOTE

A NEW UNLOADER KIT SHOULD BE USED WHEN REBUILDING. THE UNLOADER PISTONS IN THE KIT ARE PRELUBRICATED WITH A SPECIAL LUBRICANT PIECE NUMBER 239379 AND NEED NO MORE LUBRICATION.

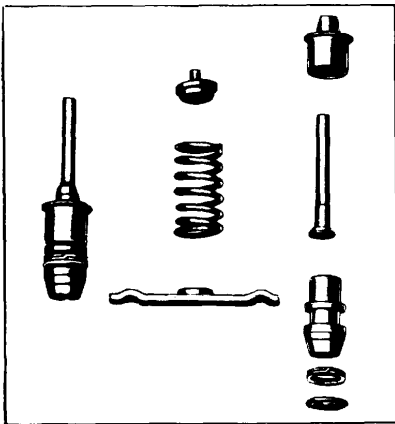

- A. Install the unloader pistons in their bores being careful not to cut the O-Rings or distort the backup rings.

- B. Position the unloader plungers in their guides and slip them in and over the tops of the pistons. Install the unloader spring seat in the crankcase inlet cavity; a small hole is drilled in the crankcase for this purpose.
 - C. Position the saddle between the unloader piston guides, so its forks are centered on the guides.
 - D. Install the unloader spring, making sure it seats over the spring seats both in the crankcase and on the saddle.
 - E. Position and install the inlet valve guides, then drop the inlet valves in their guides. There should be a loose sliding fit between the guides and valves.
4. Cylinder Head.
- A. Install the inlet valve spring in the cylinder head by applying a turning motion to the spring after it is in the head.

NOTE

THE TURNING MOTION SHOULD DIG THE SPRING WIRE INTO THE SPRING SEAT IN THE BOTTOM OF THE SPRING BORE IN THE HEAD. SHOULD THIS PROCEDURE FAIL AFTER REPEATED ATTEMPTS, USE A VERY SMALL QUANTITY OF GREASE TO HOLD THEM IN PLACE, JUST ENOUGH TO KEEP THE SPRINGS FROM FALLING OUT.

- B. Place the cylinder head gasket on the cylinder block.
 - C. Carefully align the cylinder head assembly on the block and install the cap screws, tightening them evenly to a torque of 25-30 foot pounds.
5. Base Plate or Base Adapter.
- A. Position the base plate or base adapter gasket on the crankcase and install the base plate or base adapter as marked before disassembly. Tighten the six cap screws securing the base plate or base adapter evenly to a torque of 38-45 foot pounds.

TESTING.

- 1. Compressor.

NOTE

IN ORDER TO PROPERLY TEST A COMPRESSOR UNDER OPERATING CONDITIONS, A TEST RACK FOR CORRECT MOUNTING, COOLING, LUBRICATING, AND DRIVING THE COMPRESSOR IS NECESSARY. SUCH TESTS ARE NOT COMPULSORY IF THE UNIT HAS BEEN CAREFULLY REBUILT BY AN EXPERIENCED PERSON. A COMPRESSOR EFFICIENCY OR BUILD-UP TEST CAN BE RUN WHICH IS NOT TOO DIFFICULT. AN ENGINE LUBRICATED COMPRESSOR MUST BE CONNECTED TO AN OIL SUPPLY LINE OF AT LEAST 15 POUNDS PRESSURE DURING THE TEST AND AN OIL RETURN LINE MUST BE INSTALLED TO KEEP THE CRANKCASE DRAINED.

- A. Connect to the compressor discharge port, a reservoir with a volume of 1500 cubic inches, including the volume of connecting line.

NOTE

WITH THE COMPRESSOR OPERATING AT 2100 R.P.M., THE TIME REQUIRED TO RAISE THE RESERVOIR(S) PRESSURE FROM 85 P.S.I. TO 100 P.S.I. SHOULD NOT EXCEED 5-7 SECONDS. DURING THIS TEST, THE COMPRESSOR SHOULD BE CHECKED FOR GASKET LEAKAGE AND NOISY OPERATION AS WELL, AS UNLOADER OPERATION AND LEAKAGE.

- B. Leakage past the discharge valves can be detected by removing the discharge line, applying shop air back through the discharge port and listening for escaping air.
- C. The discharge valves and the unloader pistons can be checked for leakage by building up the air system until the governor cuts out, then stopping the engine. With the engine stopped, listen for escaping air at the compressor intake.
- D. To pin-point leakage if noted, apply a small quantity of oil around the unloader pistons. If there is no noticeable leakage at the unloader pistons, the discharge valves may be leaking.

- E. If the compressor does not function as described above, or leakage is excessive, it is recommended that it be returned to the factory. If this is not possible, the compressor can be repaired, in which case, the following information should prove helpful.

LUBRICATION.

Since all Tu-Flo 501 Compressors are connected to the engine's pressurized oil system, a continuous flow of oil is provided to the compressor, which is eventually returned to the engine.

Oil is fed into the compressor in various ways, for example: through the rear end cover, the drive end of the crankshaft or through the front flange adapter. An oil passage in the crankshaft conducts pressurized oil to the precision sleeve main bearings and to the connecting rod bearings. Splash lubrication of the cylinder bores, connecting rod wrist pin bushings, and the ball type main bearings, on some models, is obtained as oil is forced out around the crankshaft Journals by engine oil pressure.

PREVENTIVE MAINTENANCE.

Every month, 300 operating hours or after each 10,000 miles depending on the operating conditions, experience and the type of strainer used, service the air strainer.

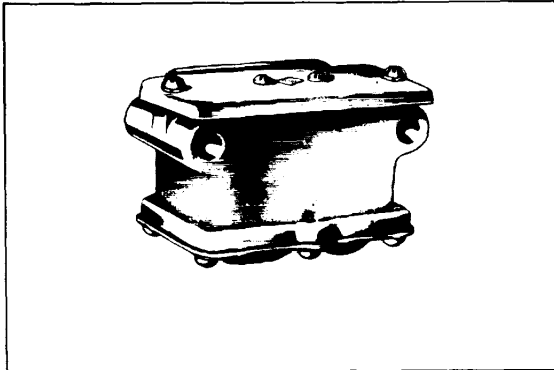

Remove and wash all of the parts. The strainer element should be cleaned or replaced. If the element is cleaned, it should be washed in a commercial solvent or a detergent and water solution. The element should be saturated in clean engine oil then squeezed dry before replacing it in the strainer. Be sure to replace the air strainer gasket if the entire air strainer is removed from the compressor intake.

EVERY 6 MONTHS, 1800 OPERATING HOURS OR AFTER EACH 50,000 MILES

Remove the discharge head fittings and inspect the compressor discharge port and discharge line for excessive carbon deposits. If excessive buildup is noted in either, the discharge line must be cleaned or replaced and the compressor checked more thoroughly paying special attention to the air induction system, oil supply and return system, and proper cooling. If necessary, repair or replace the compressor. Check for proper belt and pulley alignment and belt tension. Adjust if necessary paying special attention not to over tighten the belt tension.

Check for noisy compressor operation, which could indicate a worn drive gear coupling or a loose pulley. Adjust and/or replace as necessary. Check all compressor mounting bolts and retighten evenly if necessary. Check for leakage and proper unloader mechanism operation. Replace if defective in any way.

EVERY 24 MONTHS, 7200 OPERATING HOURS OR AFTER EACH 200,000 MILES.

Perform a thorough inspection as indicated below and depending upon the results of this inspection or experience, disassemble the compressor, clean and inspect all parts thoroughly, repair or replace all worn or damaged parts using only genuine Bendix replacements or replace the compressor with a genuine Bendix remanufactured unit.

IMPORTANT - Should it be necessary to drain the engine cooling system to prevent from freezing, the cylinder head of the compressor must also be drained.

GENERAL SERVICE CHECKS.

INSPECTION.

It is of the utmost importance that the compressor receives a clean supply of air. The air strainer must be properly installed and kept clean. If the compressor intake is connected to the engine air cleaner, supercharger, etc., these connections must be properly installed and maintained. Check the compressor mountings to be sure they are secure. Check the drive for proper alignment, belt tension, etc.

Inspect the oil supply and return lines. Be sure these lines are properly installed and that the compressor is getting the proper supply of oil, and just as important, that the oil is returning to the engine. Check the coolant lines to and from the compressor and see that the cooling fins on the crankcase are not clogged with dirt, grease, etc. Check the unloader mechanism for proper and prompt operation.

OPERATING TESTS.

Vehicles manufactured after the effective date of FMVSS 121, with the minimum required reservoir volume, must have a compressor capable of raising air system pressure from 85-100 P.S.I. in 25 seconds or less. This test is performed with the engine operating at maximum governed speed. The vehicle manufacturer must certify this performance on new vehicles with appropriate allowances for air systems with greater than the minimum required reservoir volume.

TROUBLESHOOTING

Compressor Fails to Maintain Adequate Pressure in the Air Brake System.

- Dirty intake strainer.
- Excessive carbon in compressor cylinder head or discharge line.
- Discharge valves leaking.
- Excessive wear.
- Drive belt slipping.
- Inlet valves stuck open.
- Excessive leakage of inlet valves.

TROUBLESHOOTING (continued)

Noisy Operation :

Loose drive pulley.
Excessive carbon in cylinder head or discharge line.
Worn or burned out bearings.
Excessive wear.

Compressor Passes Excessive Oil:

Excessive wear.
Dirty air strainer.
Excessive oil pressure.
Oil return line or passage to engine compressor crankcase flooded.
Oil seal ring in end cover excessively worn.
Back pressure from engine crankcase.
Piston rings improperly installed.

Compressor Does Not Unload:

Defective unloading piston grommet.
Unloading cavity plugged with carbon.
Unloading mechanism binding or stuck.

ELECTRICAL SYSTEM.

Batteries.

SPECIFIC GRAVITY TEST.

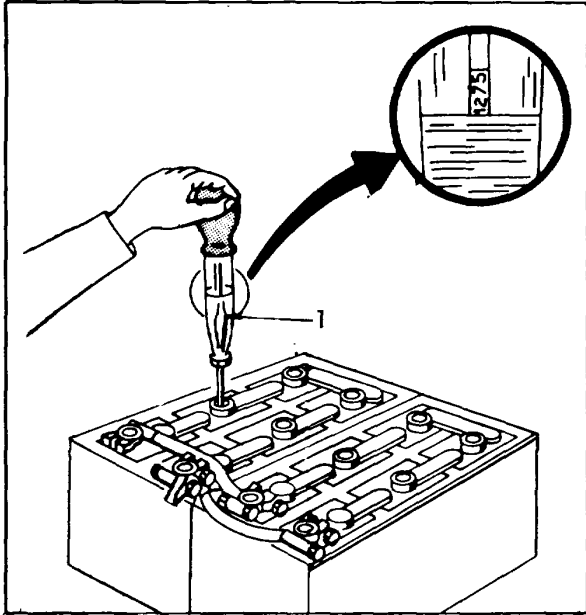

Specific gravity testing of the electrolyte determines the state of charge of each battery cell. Perform specific gravity check as follow:

1. Remove all vent caps from battery.
2. Using a hydrometer, check the specific gravity reading of each battery cell.
3. Reinstall battery vent caps.

NOTE

A SPECIFIC GRAVITY READING, IN ANY ONE CELL, OF 1.250 OR LESS, INDICATES THAT THE BATTERY REQUIRES CHARGING OR REPLACEMENT.

Adding Water to Batteries.

The water in the battery electrolyte solution evaporates at high temperatures or with excessive charging rates, therefore it may sometimes be necessary to add water to the battery. Add only clean, distilled water, as necessary, to bring the electrolyte level to 3/4-inch above the plate separators avoid overfilling the battery.

Cleaning Batteries.

The tops of the batteries, as well as the battery terminals and cable connectors, must be kept clean at all times. Clean the battery as follows:

WARNING

COVER ALL METAL AREAS OF CLEANING BRUSH WITH INSULATING TAPE PRIOR TO USE.

1. Tighten all vent caps and clean top of battery and terminals with a soft bristle brush dipped in an alkaline solution (ammonia) or a solution of bicarbonate of soda and water.
2. After foaming action of cleaning solvent stops, flush top of battery with clean water.
3. Coat terminals and cable connectors with a light coat of petroleum jelly, or equivalent.

Battery Ground Check.

A check of the battery ground connection can be made to assure the negative battery cable has a "solid" ground connection to the unit frame. Perform the check as follows:

1. Check that the negative battery cable is securely attached to the negative (-) battery terminal and the unit frame.
2. Connect the positive lead of a dc voltmeter to the unit frame close to the negative battery cable attach point.

NOTE

A DC VOLTMETER WITH A 15-VOLT SCALE (MINIMUM) SHOULD BE USED FOR THIS CHECK.

3. Connect the negative lead of the voltmeter to i.e. negative (-) terminal on the battery.
4. Motor the engine with the starter. The voltmeter should indicate "zero".
5. If a voltage reading is indicated on the voltmeter, clean and tighten the unit ground connection.
6. Disconnect voltmeter leads from battery and unit frame.

BATTERY SET REMOVAL.

WARNING

ASSURE CELL CAPS OF BATTERIES ARE SECURELY INSTALLED PRIOR TO BATTERY REMOVAL OR INSTALLATION.

KEEP BATTERIES UPRIGHT DURING REMOVAL OR INSTALLATION.

1. Disconnect positive (+) engine harness battery lead from positive (+) terminal of battery.
2. Disconnect battery paralleling cable from negative (-) and positive (+) terminals of respective batteries.
3. Disconnect negative (-) chassis ground cable from negative (-) terminal of battery.
4. Loosen attaching hardware and clamps securing batteries in battery compartment; remove batteries.

BATTERY SET INSTALLATION.

1. Position batteries in battery compartment; secure with clamps and attaching hardware.
2. Connect negative (-) chassis ground cable to negative (-) terminal of battery.
3. Connect battery paralleling cable to negative (-) and positive (+) terminals of respective batteries.
4. Connect positive (+) engine harness battery lead to positive (+) terminal of battery.

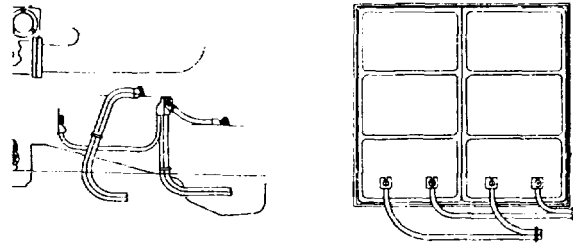

Typical 12-24 Volt Installation

Engine Instruments.

REMOVAL.

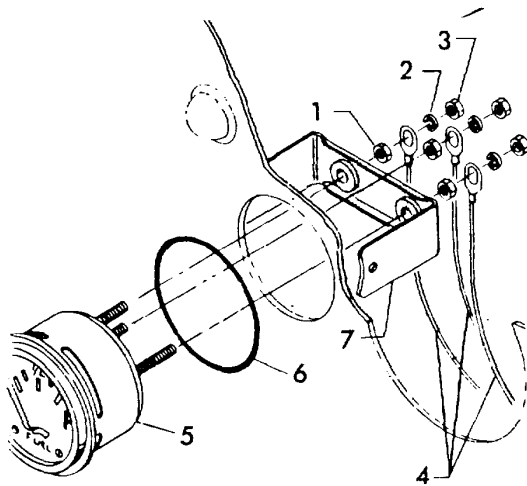

- | | |
|-------------------|---------------------|
| 1. Nut | 5. Fuel Gage |
| 2. Washer | 6. Gasket |
| 3. Nut | 7. Mounting Bracket |
| 4. Electric Leads | |

Engine Instruments.

WARNING

ASSURE BATTERIES ARE DISCONNECTED BEFORE PERFORMING ANY MAINTENANCE ON THE ELECTRICAL SYSTEM.

Remove attaching hardware to gain access to rear of instrument panel.

Remove hardware securing gage to instrument panel; remove gage.

Tag and disconnect electrical leads to gage; tape leads.

INSPECTION.

Examine gages for cracked and broken lenses. Check gage terminals and mounting studs for damage. Check wiring for damaged insulation or damaged terminals.

Engine Instruments - Installation. (Typical).

WARNING

ASSURE BATTERIES ARE DISCONNECTED BEFORE PERFORMING ANY MAINTENANCE ON THE ELECTRICAL SYSTEM.

1. Connect electrical leads as marked prior to removal.
2. Place gage into position on panel and secure with attaching hardware.
3. Secure instrument panel with attaching hardware.

FUNCTIONAL CHECK.

Start engine and observe indicators. (Refer to Operator's Handbook). Observe for proper functioning of selected indicator. Further troubleshoot as necessary, any system malfunction not corrected by repair or replacement of indicator or associated wiring.

Electric Switch.

REMOVAL.

WARNING

ASSURE BATTERIES ARE DISCONNECTED BEFORE PERFORMING ANY MAINTENANCE ON THE ELECTRICAL SYSTEM.

1. Remove attaching hardware to gain access to rear of console.
2. Remove hardware securing switch to console; remove switch.
3. Tag and disconnect electrical leads from switch; tape leads.

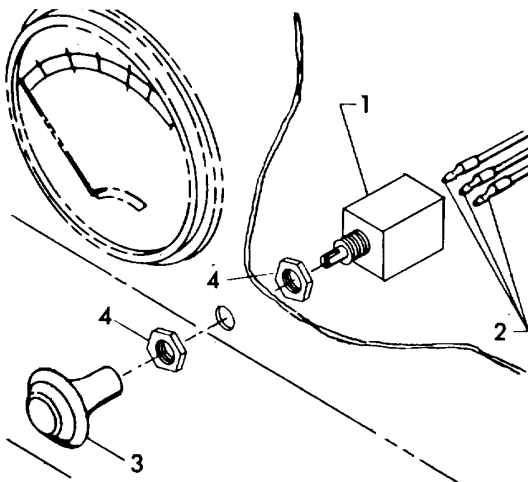

- | | |
|---------------------|---------|
| 1. Switch | 3. Knob |
| 2. Electrical Leads | 4. Nut |

Electrical Switch.

INSPECTION.

1. Visually check switch for evidence of cracks, damaged connections or other damage.
2. Check wiring for damaged insulation or damaged terminals.
3. Perform the following check to determine switch serviceability.
 - a. Using an ohmmeter or continuity light, check for continuity between switch terminals with switch in ON or activated position.
 - b. Position switch to OFF, ohmmeter should register zero (no continuity).

INSTALLATION.

Electrical Switch.

WARNING

ASSURE BATTERIES ARE DISCONNECTED BEFORE PERFORMING ANY MAINTENANCE ON THE ELECTRICAL SYSTEM.

1. Connect electrical leads as marked prior to removal.
2. Place switch into position on panel and secure with attaching hardware.
3. Secure instrument panel with attaching hardware.

Electrical Switch - Functional Check.

Operate switch as described in Operator's Handbook. Observe for proper function-

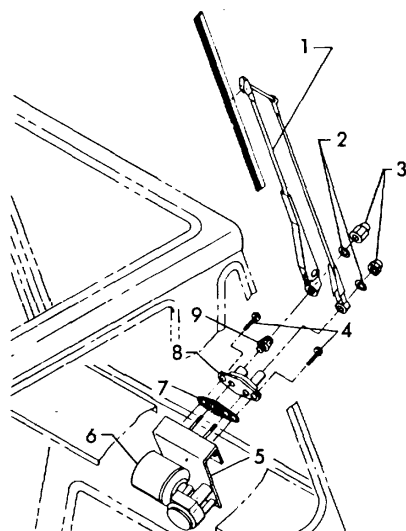

Windshield Wiper Assembly.'

REMOVAL.

WARNING

ASSURE BATTERIES ARE DISCONNECTED BEFORE PERFORMING ANY MAINTENANCE ON THE ELECTRICAL SYSTEM.

1. Tag and disconnect electrical leads to motor; tape leads.
2. Remove nuts and washers securing wiper arms; remove wiper arms.
3. Remove cap screws securing mounting plate to motor mounting bracket.
4. Remove serrated collar.
5. Remove motor and mounting bracket, mounting plate and gasket.

- | | | |
|------------|---------------------|---------------------|
| 1. Arm | 4. Screws | 7. Gasket |
| 2. Washers | 5. Mounting Bracket | 8. Mounting Bracket |
| 3. Nuts | 6. Motor | 9. Knob |

Windshield Wiper Assembly - Inspection.

Visually check motor housing for evidence of cracks or other damage. Check for excessive shaft end play indicating worn or damaged bearings. Inspect wiper blade for serviceability.

Windshield Wiper Assembly.

INSTALLATION

1. Install motor and mounting bracket, mounting plate and gasket in position.
2. Secure mounting plate to motor mounting bracket with attaching cap screws.

3. Install serrated collar.
4. Install wiper arms; secure with attaching washers and nuts.
5. Connect electrical leads to motor as marked prior to removal.

HEATER ASSEMBLY.

The heater assembly is installed to the rear of the operator's seat. Circulation of air is provided by a fan within the assembly controlled by a rotary switch on the console.

Heater Assembly.

REMOVAL.

WARNING

ASSURE BATTERIES ARE DISCONNECTED BEFORE PERFORMING ANY MAINTENANCE ON THE ELECTRICAL SYSTEM.

NOTE

A SUITABLE CONTAINER SHOULD BE AVAILABLE TO CATCH DRAWING COOLANT.

1. Disconnect electrical lead to motor; tape lead.
2. Loosen clamps securing hoses to heater pipes; remove hoses; plug hose openings.
3. Remove nuts securing heater assembly to cab; remove assembly.

DISASSEMBLY. (Illus. 4-57).

1. Remove hardware securing grill and cover to back plate.
2. Remove cover and heater core.
3. Loosen set screw securing fan blade to motor shaft; remove blade.
4. Remove hardware securing motor to back plate; remove motor.

REASSEMBLY.

1. Install motor on back plate; secure with attaching hardware.
2. Position fan blade on motor shaft; secure with set screw.
3. Assemble back plate, heater core, cover and grill together; secure with attaching hardware.

INSTALLATION.

1. Set heater assembly into position in cab; secure with attaching hardware.
2. Remove plugs from heater hoses; install hoses; secure with clamps.
3. Connect electrical lead to motor.

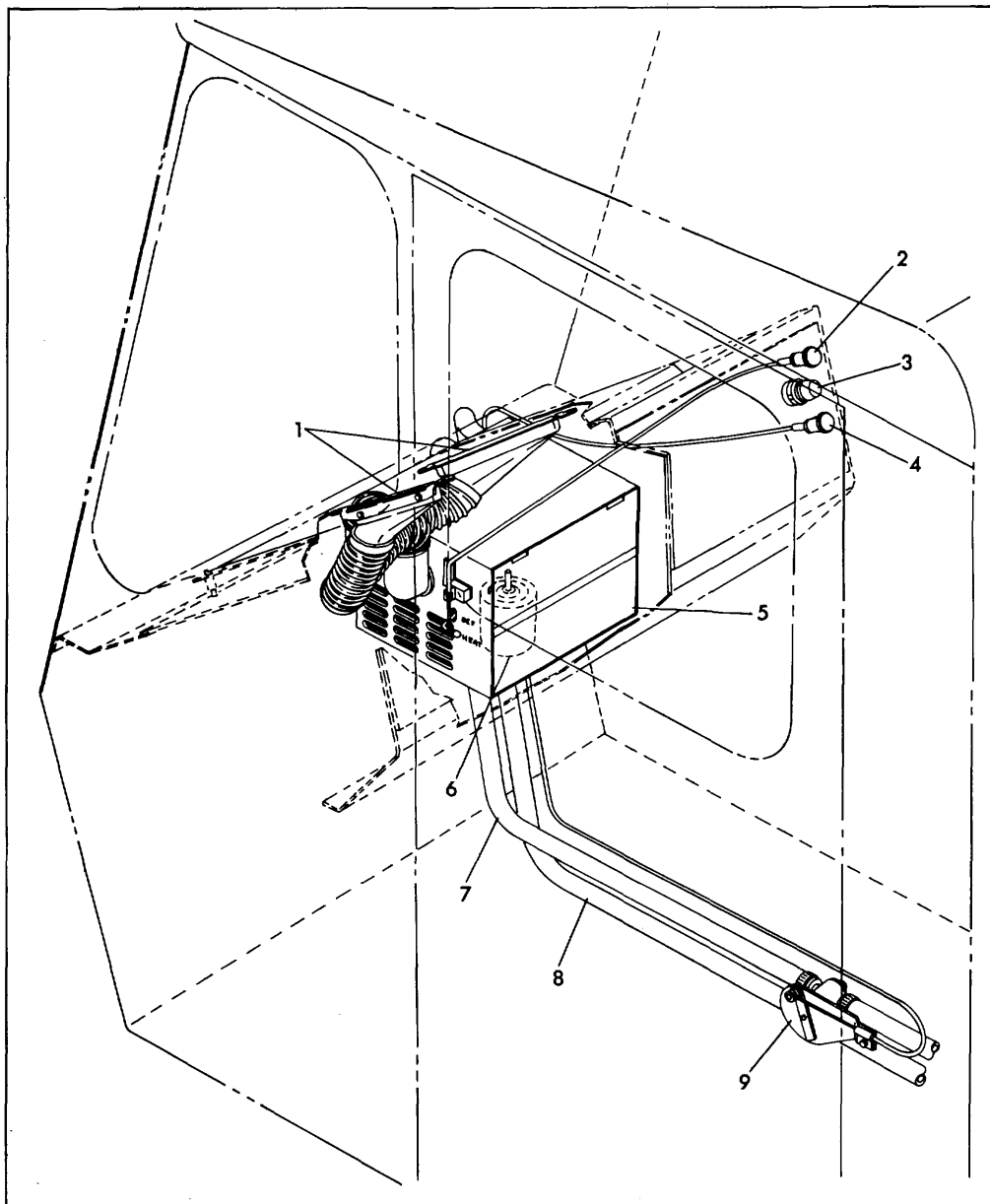

- | | | |
|--------------------------------|----------------------|-----------------------|
| 1. Defroster Outlets | 4. Heat Control Knob | 7. Inlet Hose |
| 2. Heat/Defroster Control Knob | 5. Heater Housing | 8. Outlet Hose |
| 3. Fan Switch | 6. Fan Motor | 9. Heat Control Valve |

Illustration 4-57. Heater Assembly

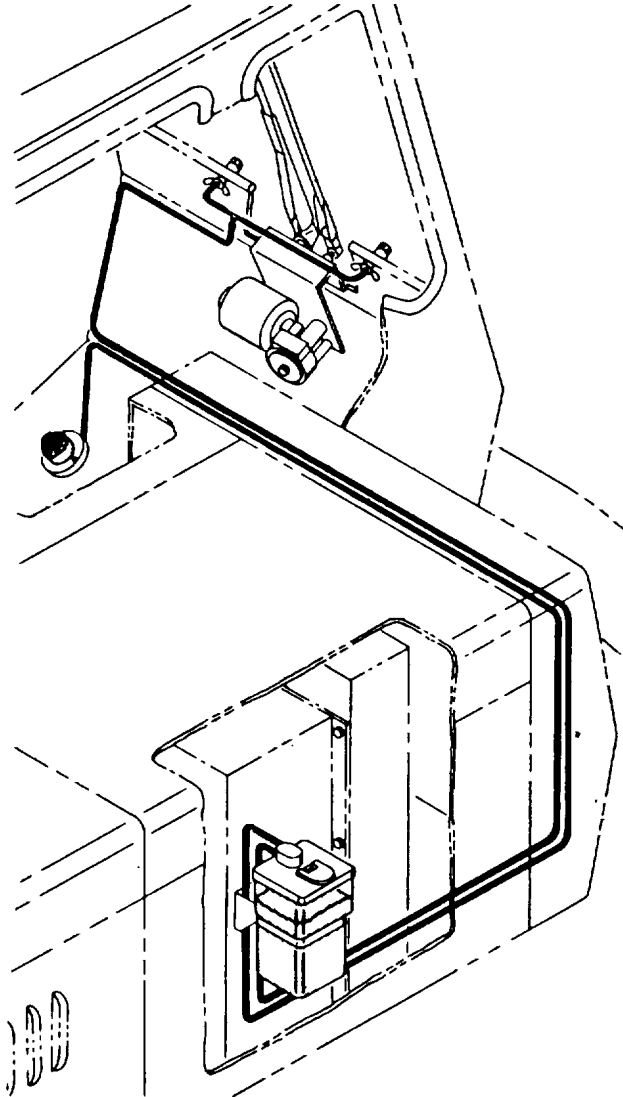

Windshield Washer System.

These units are air operated by depressing the bellows type foot pump located to the left of the steering column base. The amount of force applied by pressing down on the pump will determine the height of fluid projection on the windshield glass.

Maintenance.

These units require a minimum of attention, however the hose and piping should frequently be examined for deterioration, kinks or loose fittings.

The water projection nozzles can be adjusted to direct the fluid as desired. Care should be taken not to distort the nozzle when adjustment is made.

Use only anti-freeze type windshield washer fluid in the reservoir to prevent freezing and accumulation of sediment. The reservoir is located in the engine compartment.

Alcohol Evaporator System. (Illus. 4-23).

The consumption of alcohol will vary on different vehicles. The main determining factor on a properly installed and maintained unit is the percentage of time the compressor is in its loaded (compressing air) cycle. Being that the use of alcohol only occurs when the compressor is compressing air, good maintenance practice should be followed by keeping leakage within allowable limits, adjusting brakes, etc.

While it is difficult to advise what amount of alcohol each vehicle will use, we can set forth an example that can be used as a guide in determining if the alcohol evaporator is working properly.

Alcohol usage 30 cc to 70 cc (1 oz. to 2 oz.) per hour
(compressor continuously pumping)

Assuming a compressor on a highway tractor-trailer running for 12 hours will be loaded (compressing air) 20% of the total operating time of 12 hours or roughly 2.5 hours, by multiplying 70 cc (maximum usage of alcohol) by 2.5 hours, we have a usage of approximately 175 cc (approximately 1/3 to 1/2 pt. 1 pt. 474 cc) of alcohol in 12 hours. It can then be easily seen by additional calculations that if the compressor is operating a greater percentage of the time more alcohol will be used.

It is recommended that only pure methanol alcohol be used in the air brake system. Bendix-Westinghouse markets this alcohol under the name "Air Guard" or its equivalent in a correctly installed and maintained alcohol evaporator and proper draining of all reservoirs in the air brake system is the best insurance against air brake system freeze-ups.

PREVENTIVE MAINTENANCE.

1. Every three months, 900 operating hours, or 25,000 miles:
 - A. Check to be sure all fittings are tight and bubbles are present in the alcohol when compressor is compressing cycle. (If not operating properly, see troubleshooting guide).
2. Every six months, 1800 operating hours, or 50,000 miles:
 - A. If strainer is present, check to be sure it is clear. Clean or replace if necessary.
3. Every year, 3600 operating hours, or 100,000 miles:
 - A. Disassemble evaporator and check valve (if so equipped) clean all parts, replacing all gaskets and rubber parts.

TESTING.

With compressor in compressing cycle, bubbles should be evident in alcohol. If air bubbles are not present, check troubleshooting guide.

REMOVAL.

1. Disconnect connecting lines.
2. Remove mounting bolts.

INSTALLATION.

1. Determine proper kit to be installed (see "Installation of Alcohol Evaporators").
2. Select a location where alcohol evaporator will not be subjected to temperatures in excess of 120°F.
3. Mount Alcohol Evaporator.
4. Refer to installation instructions (furnished with kit) and install lines.(On standard kit and engine air cleaner induction kit, 3/16" line from compressor to evaporator should not be longer than five (5) feet).
5. After installation has been completed, fill the alcohol reservoir 2/3 full of alcohol.

CAUTION

IT IS IMPORTANT THAT THE CORRECT ALCOHOL BE USED. SEE SECTION ON "TYPE OF ALCOHOL TO BE USED".

6. Check to be sure Alcohol Evaporator is operating properly. See section "Testing For Serviceability".

FILLING.

1. Always use the filler plug. Frequent removal of the alcohol reservoir will cause possible deterioration of the gasket, which will allow leakage and affect performance. (AE-1 evaporator only).
2. Fill the reservoir 2/3 full. Be certain the proper alcohol is used. See section "Type of Alcohol To Be Used".

DISASSEMBLY, ASSEMBLY, CLEANING AND INSPECTION.

1. Carefully disassemble, noting order of removal of parts.
2. Wash all metal parts in solvent, wipe all rubber parts clean.
3. Inspect all parts, and replace all parts not considered serviceable.
4. Assemble parts, making certain new gaskets, rubber parts are properly installed.

TESTING OF REBUILT ALCOHOL EVAPORATOR.

Perform test outlined "Testing for Serviceability" section.

TROUBLE SHOOTING ALCOHOL EVAPORATORS

PROBLEM	POSSIBLE CAUSE	REMEDY
1. Alcohol Evaporator Does Not Operate.	1. Wrong kit installed	1. Install proper kit.

TROUBLE SHOOTING

PROBLEM	POSSIBLE CAUSE	REMEDY
<p>(Note: Proof that evaporator is functioning can be determined by: material, kinked, etc.)</p>	<p>1a. Kit is piped incorrectly</p> <p>1b. Lines restricted (foreign lines).</p> <p>1c. Alcohol evaporator filter clogged. (Standard and Engine Air Cleaner Induction Kit).</p> <p>1d. Leaky fittings, lines, jar cover gasket, or filler cap gasket.</p> <p>1e. 3/16" line from compressor to alcohol evaporator longer than five (5) feet (Standard Kit and Engine Air Cleaner Induction Kit only)</p> <p>1f. Compressor not in loaded (compressing air) cycle</p> <p>1g. Check valve stuck in closed position.</p> <p>Cleaner Induction Kit only)</p>	<p>1a. Check diagram for correct piping.</p> <p>1b. Clean or replace</p> <p>1c. Clean or replace filter material.</p> <p>1d. Tighten or replace necessary parts.</p> <p>1e. Line from compressor to alcohol evaporator should not be longer than five (5) feet. (Standard Kit and Engine Air Cleaner Induction Kit only).</p> <p>1f. By observing dash gauge, make certain compressor is in loaded (compressing air) cycle.</p> <p>1g. Replace necessary (Engine Air parts or complete check valve.</p>
<p>2. Excessive Use of Alcohol</p>	<p>2. Wrong kit installed. (i.e If a compressor receives its air through the engine air cleaner and a standard kit is installed without check valve, it is possible for alcohol to be drawn into the engine).</p> <p>2a. Leaky compressor unloader (Supercharge and Turbo-Charge Induction Kits only). Leaky unloader can cause alcohol to be "blown" into the engine intake.</p>	<p>2 Install proper kit.</p> <p>2a. Replace compressor unloader.</p>

TROUBLE SHOOTING

PROBLEM	POSSIBLE CAUSE	REMEDY
2. Excessive Use of Alcohol. (continued)	<p>2b. Evaporator is subjected to excessive temperature (Greater than 120°).</p> <p>2c. Check valve leaking or inoperative. (Engine Air Cleaner Induction Kit only).</p> <p>2d. Excessive system leak age (causing compressor to be in loaded compressing air cycle in excess of normal)</p> <p>2e. Choke fitting (Part No 245103) not used. (Supercharged and Turbo-Charged Induction Kits only)</p> <p>2f. Clogged air strainer (will cause excessive intake vacuum). (Standard Kit only).</p>	<p>2b. Relocate alcohol evaporator.</p> <p>2c. Replace necessary parts or complete check valve.</p> <p>2d. Check system leakage. Leakage should not be greater than 2 psi in one minute for single vehicles or 3 psi in one minute for tractor-trailer combinations (with brake released).</p> <p>2e. Install choke fitting (Part No. 245103) at compressor inlet.</p> <p>2f. Clean or replace air strainer element.</p>
3. Deposit of Residue in Valves from Alcohol	3. Wrong alcohol being used	3. Use only pure methanol alcohol. Bendix-Westinghouse "Air Guard" or equivalent.
4-370		

ADDENDUM A
1978 EPA NOISE ABATEMENT PROGRAM
(40 CFR PART 205)

This crane is affected by the 1978 EPA Noise Abatement Program. The following guidelines are provided to ensure compliance with the program.

1.0. Maintenance Noise Reduction Items General

- (a) Whenever maintenance is performed which affects any of the parts listed in the Grove Service Manual, then those parts affected shall be inspected to ensure no damage has occurred and that the installation has not been degraded.

NOTE

To ensure compliance with the Federal Regulations with respect to tampering; it is mandatory that parts replacement be made in accord with the parts listing shown in the Grove Service Manual.

1.1. Maintenance:

1.1.1. Periodic Maintenance To be performed at 60 day intervals.

- (a) Visually inspect all noise related parts, as shown in the parts listing of the Grove Service Manual, for indication of impending failure and improper installation.
- (b) With the system operating, check for exhaust gas leaks and abnormal movement in the system.
- (c) If a malfunction is detected, replace the failed part or correct the defect as required.

1.1.2. Malfunctions If the following defects are noted:

- (a) Noticeable increase in noise level.
- (b) Exhaust gas discharge at points other than the normal exhaust exit.

Then visually inspect the system to locate the problem and perform the required corrective action.

Tampering With Noise Control System Prohibited





Federal law prohibits the following acts or the causing thereof: (1) The removal or rendering inoperative by any person other than for purposes of maintenance repair, or replacement, of any device or element of design incorporated into any new vehicle for the purpose of noise control prior to its sale or delivery to the ultimate purchaser or while it is in use, or (2) the use of the vehicle after such device or element of design has been removed or rendered inoperative by any person.

Parts affected by the above statement follow. The part numbers are Grove's.

DETROIT ENGINE INSTALLATION

<u>P/N</u>	<u>NOMENCLATURE</u>
7-414-000242	6-71N Engine Assy.
7-364-000703	Horizontal Shaft
7-364-000702	Horizontal Shaft
7-364-000709	Propeller Shaft
7-642-000045	Muffler
7-258-000303	Weather Cap
7-910-004476	Exhaust Tube
7-304-000024	Air Cleaner
7-364-000714	Exhaust Pipe Connector
7-910-004477	Exhaust Tube

**ADDENDUM B
PARTS CATALOG
(CARRIER)**

DRIVE TRAIN GROUP 
AXLE GROUP 
FRAME GROUP 
CAB GROUP 
ENGINE GROUP 

B-1

INSTRUCTIONS FOR USING THIS PARTS CATALOG

The next few pages make up the Machine Component Index. This Index is a list of the component Part Numbers and their Descriptions which were used to build the crane Model and Serial Number recorded on this catalog.

Each part number listed under the Part Number column of the Index represents an installation arrangement of a group of parts, a schematic, a diagram or a particular assembly, depending on each number's word description.

Each parts list within this catalog is related to a ten-digit Part Number. The part number is located at the bottom of it's related parts list and also it's related illustration when the part number listing and illustration are on separate pages. These part numbers correspond with the Machine Component Index and are arranged in the same sequence. When ordering replacement parts use only those part numbers and word descriptions found on the parts list.

By referring to the Machine Component Index one can locate the major groups and the related parts breakdowns within these groups.

B-1.2

CARRIER

MACHINE COMPONENT INDEX

MODEL: TMS300-5

PART NUMBER	PART DESCRIPTION	ILLUSTRATION PAGE NUMBER
<u>DRIVE TRAIN GROUP</u>		
2-130-100113	DRIVE LINE INSTALLATION	B-3
7-364-000703	HORIZONTAL SHAFT	B-4
7-364-000702	HORIZONTAL SHAFT	B-5
7-364-000709	PROPELLER SHAFT	B-6
6-904-000076	FULLER TRANSMISSION ASSEMBLY - COMPLETE	B-7
7-904-000078	FULLER TRANSMISSION COMPONENTS: SHEETS 1 thru 15	B-8 thru B-20
<u>AXLE GROUP</u>		
6-049-000239	FRONT AXLE & STEERING ASSY & INST	B-24
7-490-000037	STEERING GEAR ASSEMBLY	B-28
7-049-000209	AXLE ASSEMBLY - FRONT	B-30, B-32
7-049-000210	AXLE ASSEMBLY - REAR	B-34, B-36
7-372-000872	STEER CYLINDER ASSEMBLY	B-38
7-601-000071	DRAG LINK & STEERING VALVE ASSEMBLY	B-39
6-049-000219	REAR AXLE ASSEMBLY & INSTALLATION	B-41
7-049-000297	AXLE ASSEMBLY - FRONT REAR	B-44 thru B-55
7-049-000298	AXLE ASSEMBLY - REAR REAR	B-56 thru B-65
7-364-000515	INNER AXLE SHAFT	B-66
SK 771046	REAR AXLE AIR SCHEMATIC	B-67
2-130-600069	POWER STEERING SCHEMATIC	B-68
6-970-000237	TIRE ASSEMBLY (FRONT) 11:00 X 20-14 PLY	B-69
6-970-000232	TIRE ASSEMBLY (REAR) 11:00 X 20-12 PLY	B-70
6-970-000237	SPARE TIRE & WHEEL ASSEMBLY	B-71
SK772208	SPARE TIRE HANGER INSTALLATION	B-72
SK772325	AXLE STOP INSTALLATION	B-73, B-74

MACHINE COMPONENT INDEX

MODEL: TMS300-5

PART NUMBER	PART DESCRIPTION	ILLUSTRATION PAGE NUMBER
<u>FRAME GROUP</u>		
2-130-100100	FRONT FENDERS & BATTERY BOX INSTALLATION	B-76
2-130-100026	REAR FENDER INSTALLATION	B-79
2-130-800042	FUEL TANK INSTALLATION	B-80
6-880-000100	HYD RESERVOIR ASSEMBLY & INSTALLATION	B-82
6-437-000057	OIL FILTER ASSEMBLY	B-84
6-581-000182	EXTERIOR LIGHTS & HORN INSTALLATION	B-86
2-147-600075	SUPPLY, PRESSURE & RETURN-HYD SCHEMATIC	B-88
7-926-000797	SEQUENCE VALVE	B-91
2-130-600067	AIR SYSTEM SCHEMATIC	B-92, B-93
6-880-000056	AIR TANK INSTALLATION	B-97
7-926-000608	SPRING BRAKE CONTROL VALVE	B-99
6-880-000116	POWER STEERING RESERVOIR INSTALLATION	B-101
2-147-600037	TUBE SUPPORT INSTALLATION	B-102
2-147-100011	MUD GUARD INSTALLATION	B-104
2-137-100128	ACCESS LADDER INSTALLATION	B-105
6-869-000307	JIB ACCESS LADDER INSTALLATION	B-106
SK772229	SLING BOX INSTALLATION	B-107
SK772264	PILE DRIVER SUPPORT PLATE STORAGE INST	B-108

B-1.4

MACHINE COMPONENT INDEX

MODEL: TMS300-5

PART NUMBER	<u>PART DESCRIPTION</u>	ILLUSTRATION PAGE NUMBER
<u>CAB GROUP (CARRIER)</u>		
SK771994	CAB ASSEMBLY & INSTALLATION	B-110
SK771982	CAB WELDMENT & ASSEMBLY	B-113
SK772243	WIRING HARNESS INSTALLATION	B-114
2-137-400009	ELECTRIC WINDSHIELD WIPER INSTALLATION	B-115
6-033-000153	WINDSHIELD WASHER INSTALLATION	B-116
6-798-000024	SEAT & SEAT BELT INSTALLATION	B-117
7-926-000644	DUAL BRAKE VALVE	B-120
SK772257	CAB DOOR ASSEMBLY	B-123
SK772270	INSTRUMENTS & LIGHTS INSTALLATION	B-124
SK771995	WIRING DIAGRAM	B-127
SK772410	REAR VIEW MIRROR INSTALLATION'	B-128
SK771944	SUN VISOR INSTALLATION	B-129
6-001-000345	ACOUSTICS INSTALLATION	B-130
<u>ENGINE GROUP (CARRIER)</u>		
2-130-800057	ENGINE & TRANSMISSION ASSY & INST (GMC 6-7IN & FULLER RTO-613T)	B-134
6-294-002174	WIRING DIAGRAM	B-139, B-140
7-372-000303	THROTTLE CYLINDER	B-141
6-372-001167	CLUTCH & SLAVE CYLINDER INSTALLATION	B-142
7-316-000007	CLUTCH ASSEMBLY	B-144
7-352-000027	SLAVE UNIT CONTROL	B-146
6-372-000742	SLAVE CYLINER ASSEMBLY	B-147
7-926-000542	FLOW CONTROL VALVE	B-148
6-352-000034	MASTER CONTROL UNIT	B-149
2-130-800035	QUICK START INSTALLATION	B-151
6-726-000076	RADIATOR & OIL COOLER INSTALLATION	B-152
2-130-800009	TRANSMISSION SHIFT INSTALLATION	B-154
2-130-800025	THROTTLE INSTALLATION	B-156

MACHINE COMPONENT INDEX

MODEL: TMS300-5

PART NUMBER	PART DESCRIPTION	ILLUSTRATION PAGE NUMBER
6-064-000024	BATTERY INSTALLATION	B-158
7-926-000806	RELAY VALVE	B-159
6-304-000053	EXHAUST SYSTEM INSTALLATION	B-160
6-304-000036	AIR CLEANER INSTALLATION	B-161
7-304-000024	AIR CLEANER ASSEMBLY	B-162
6-978-000505	WIRING HARNESS INSTALLATION	B-163
2-137-100138	ALCOHOL EVAPORATOR INSTALLATION	B-164, B-165
7-348-000062	ALCOHOL EVAPORATOR	B-166
7-926-000530	CHECK VALVE	B-167
6-722-000125	CONSTANT SPEED PUMP & MANIFOLD INST	B-168
7-722-000054	TWO SECTION PUMP ASSEMBLY	B-170
7-722-000085	PUMP DRIVE W/DISCONNECT	B-172
7-810-001415	PROPELLER SHAFT ASSEMBLY	B-174
2-147-800013	HYDRAULIC SUCTION TUBE INSTALLATION	B-175
6-294-002688	WIRING DIAGRAM (CARRIER)	
2-147-400084	ENGINE HOOD ASSEMBLY & INSTALLATION	B-176
6-294-001863	WIRING DIAGRAM	B-179
2-130-100095	CLUTCH MASTER CYLINDER & SLAVE CYLINDER	B-182
6-372-001169	HYDRAULIC LINE INSTALLATION	B-183, B-184
	MASTER CYLINDER ASSEMBLY	B-185
6-978-000481	WIRING HARNESS INSTALLATION	B-186
6-978-000446	WIRING HARNESS INSTALLATION	B-187
2-120-400007	FUSE & CONNECTOR PANEL ASSEMBLY	B-190

**ADDENDUM B
PARTS CATALOG
(CARRIER)**

DRIVE TRAIN GROUP

B-2 (B-2/1 Blank)

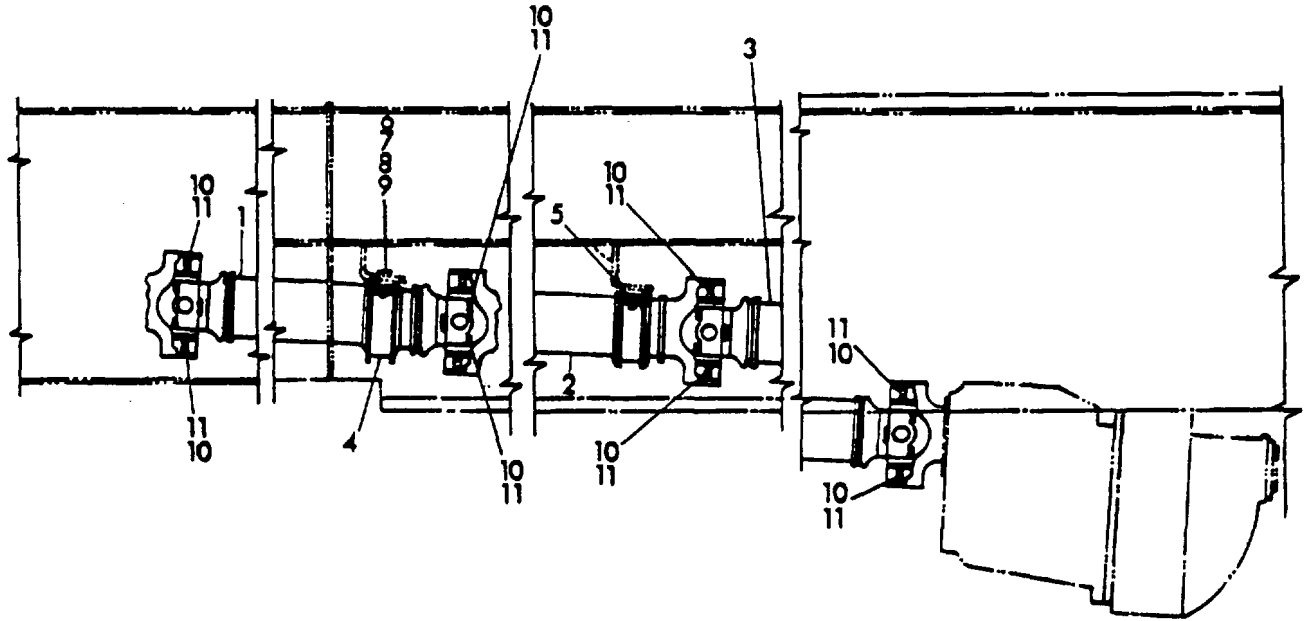

REF NO.	PART NUMBER	DESCRIPTION	NO. REQ 'D
DRIVE LINE INSTALLATION			
*1	7364000703	Shaft, Horizontal-----	1
*2	7364000702	Shaft, Horizontal-----	1
*3	7364000709	Shaft, Propeller -----	1
4	7069000129	Bearing, Drive Line Center -----	2
5	6705006026	Plate, Spacer -----	A/R
6	MS90725115	Bolt, Hex Head 1/2"13 N.C. x 2" Length - Grade 5 -----	4
7	MS2718318	Flatwasher .095 Thick x 17/32" I.D. x 1 1/16" O. D. Steel-----	4
8	MS5196714	Nut, Hex 1/2"13 N.C. Grade A-----	4
9	MS3569133	Nut, Jam 1/2"13 N.C. Grade A -----	4
10	MS3534048	Lockwasher 1/2" Heavy Spring Steel -----	16
11	7108182050	Screw, Hex Head Cap-----	16

A/R As Required

"Part numbers denoted by an asterisk identifies those descriptive items that comprise the anti tampering portion of 40 CFR Part 205 EPA noise regulation. Prior to replacement, refer to your service manual for a complete list of these items that meet the criteria and is consistent with the "list of tampering acts" published in your operators handbook."

If further clarification or questions arise, please advise.

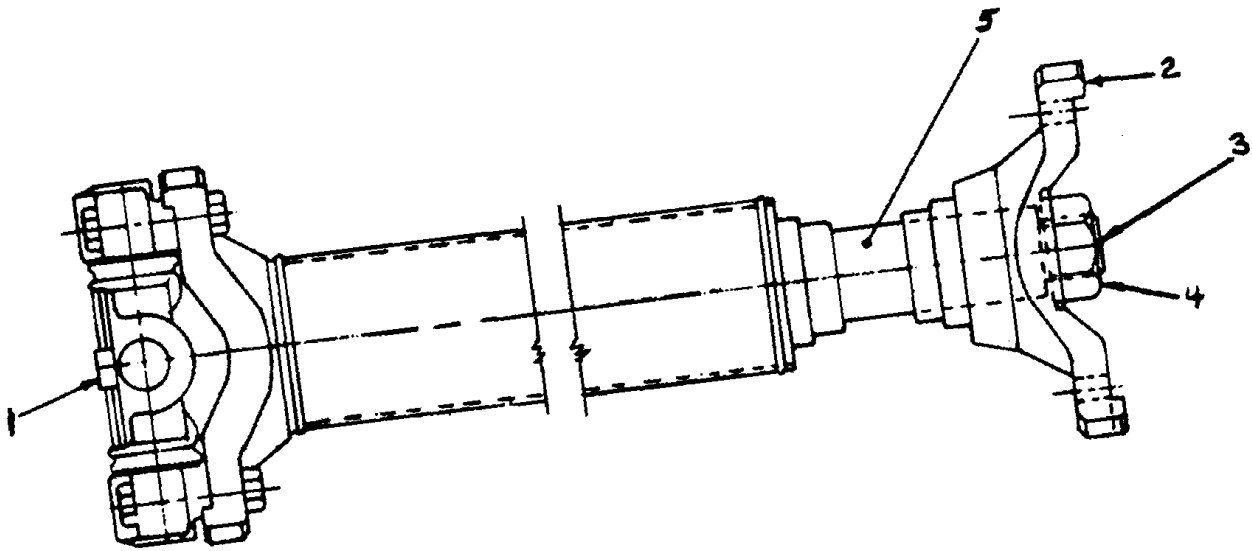

REF. NO.	PART NUMBER	DESCRIPTION	NO. REQ'D
		HORIZONTAL SHAFT	
	7-364-000703	Horizontal Shaft	
1	9-364100280	"U" Joint -----	1
2	9-274-100280	Flange -----	1
3	9-274-100281	Pin, Cotter -----	1
4	9-364-100101	Nut, Slotted -----	1
5	Not Serviced	Use Complete Assembly	

7-364-000703

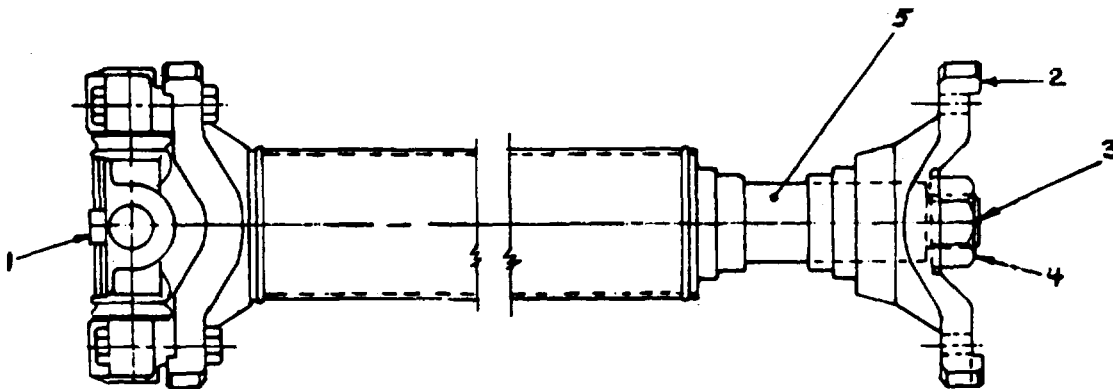

REF NO	PART NUMBER	NO.	DESCRIPTION	REQ'D
			HORIZONTAL SHAFT	
	7-364-000702		Horizontal Shaft	
1	9-364-100280		"U" Joint-----	1
2	9-274-100280		Flange-----	1
3	9-274-100281		Pin, Cotter-----	1
4	9-364-100101		Nut, Slotted-----	1
5	Not Serviced		Use Complete Assembly	

7-364-000702

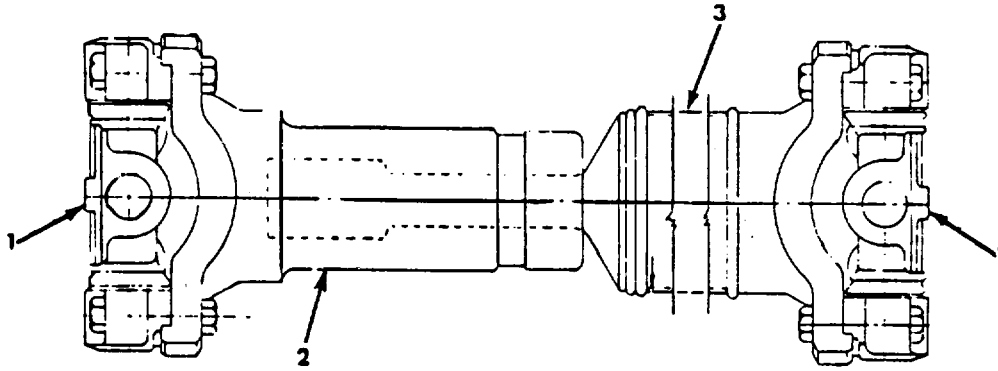

REF NO	PART NUMBER	NO.	DESCRIPTION	REQ'D
	7-364-000709		Propeller Shaft	
1	9-364-100280		"U" Joint-----	2
2	9-364-100281		Yoke -----	1
3	Not Serviced		Use Complete Assembly	

7-364-000709

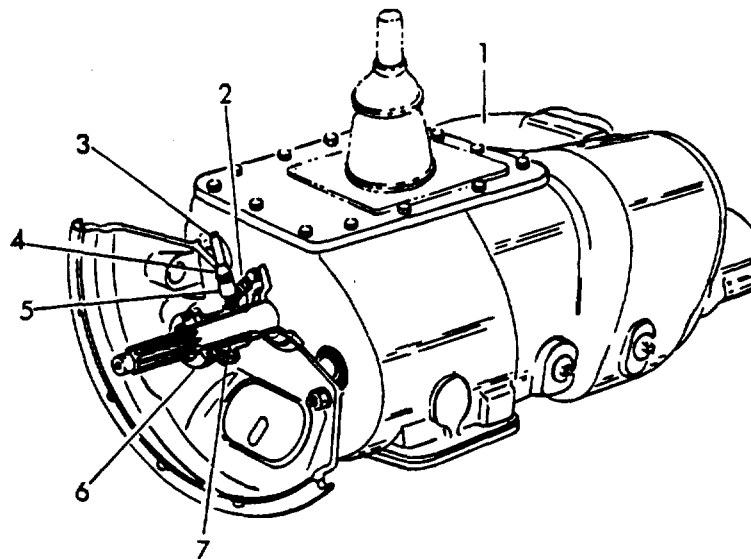

REF NO	PART NUMBER	NO.	DESCRIPTION	REQ'D
FULLER TRANSMISSION - RTO 613 W/RELEASE PARTS FOR L.R; 14-2 DPB CLUTCH				
1	7-904-000078		Fuller Transmission -----	1
2	7-834-000128		Spring-----	2
3	7-543-000674		Hose -----	1
4	7-444-000140		Coupling-----	1
5	6-650-010060		Nipple-----	1
6	7-069-000273		Bearing-----	1
7	7-270-000378		Carrier -----	1
				6-904-000076

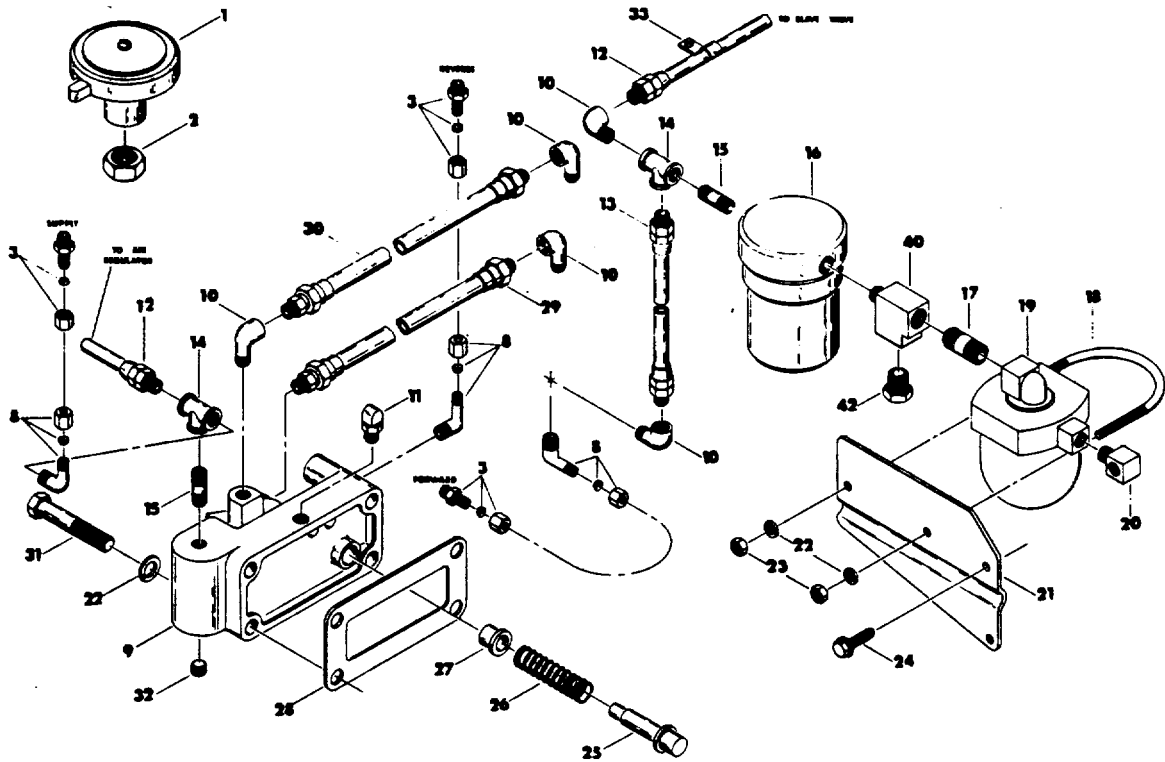

REF NO	PART NUMBER	NO.	DESCRIPTION	REQ'D
AIR SYSTEM				
1	9-904-103213		Selector Valve Assembly-----	1
2	9-904-102849		Nut-----	1
3	9-904-102073		Connector Assembly (3 Pieces)-----	3
5	9-904-102074		"O" Ring (Not Shown)-----	2
8	9-904-102051		Elbow Assembly (3 Pieces) -----	3
9	9-904-102069		Slave Valve Assembly -----	1
10	9-904-102070		Street Elbow-----	5
11	9-904-101905		Breather Valve-----	1
12	9-904-102112		Hose -----	1
13	9-904-102103		Hose -----	1
14	9-904-102050		Tee -----	2
15	9-904-102098		Pipe Nipple -----	2
16	9-904-102104		Air Regulator Valve-----	1
17	9-904-102095		Pipe Nipple -----	1
18	9-904-102093		"V" Bolt -----	1
19	9-904-102090		Air Filter Assembly-----	1
20	9-904-102091		Street Elbow-----	1
21	9-904-102094		Bracket -----	1
22	9-904-102067		Lockwasher -----	6
23	9-904-103370		Nut-----	2
24	9-904-102097		Capscrew -----	1
25	9-904-102064		Pin -----	1
26	9-904-102053		Spring-----	1
27	9-904-102066		Sleeve -----	1

REF. NO.	PART NUMBER	DESCRIPTION	NO. REQ'D
AIR SYSTEM			
28	9-904-102052	Gasket-----	1
29	9-904-102110	Hose -----	1
30	9-904-102111	Hose -----	1
31	9-904-102068	Capscrew -----	1
32	9-904-102113	Pipe Plug-----	1
33	9-904-102105	Clamp-----	1
40	9-904-102096	Tee -----	1
42	9-904-102089	Bushing-----	1

7-904-000078

Sheet 2 OF 15

B-9

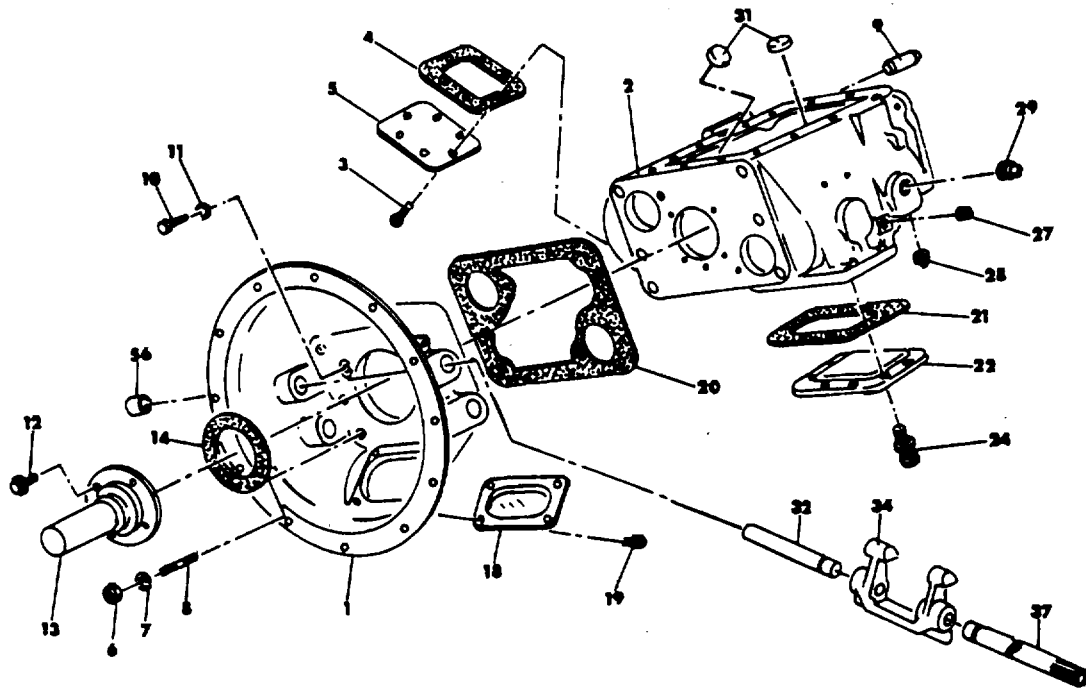

REF. NO.	PART NUMBER	DESCRIPTION	NO. REQ'D
MAIN HOUSING ASSEMBLY (CLUTCH)			
1	9-904-103371	Clutch Housing Assembly-----	1
2	9-904-101976	Case, (Transmission)-----	1
3	9-904-101881	Capscrew-----	6
4	9-904-101883	Gasket-----	1
5	9-904-101882	P.T.O Cover-----	1
6	9-904-101827	Nut-----	6
7	9-904-101828	Lockwasher-----	6
8	9-904-101934	Stud-----	6
9	9-904-101939	Dowel Pin-----	2
10	9-904-101257	Capscrew-----	2
11	9-904-101254	Lockwasher-----	2
12	9-904-101267	Capscrew-----	2
13	9-904-101962	Front Bearing Cover-----	1
14	9-904-101970	Gasket-----	1
18	9-904-101731	Hand Hole Cover-----	1
19	7-111-150450	Capscrew-----	4
20	9-904-101933	Gasket-----	1
21	9-904-102106	Gasket-----	1
22	9-904-102107	P.T.O Cover-----	1
24	9-904-103372	Capscrew-----	8
27	9-904-102083	Pipe Plug-----	1
28	9-904-102085	Pipe Plug-----	1
29	9-904-101887	Pipe Plug-----	1
31	9-904-102084	Magnet-----	2

7-904-000078

REF. NO.	PART NUMBER	DESCRIPTION	NO. REQ'D
		MAIN HOUSING ASSEMBLY (CLUTCH)	
32	9-904-102109	Pedal Shaft-----	1
34	9-904-102123	Release Yoke Kit-----	1
37	9-904-103226	Pedal Shaft-----	1
56	9-904-102661	Bushing-----	8

7-904-000078

Sheet 4 OF 15

B-11

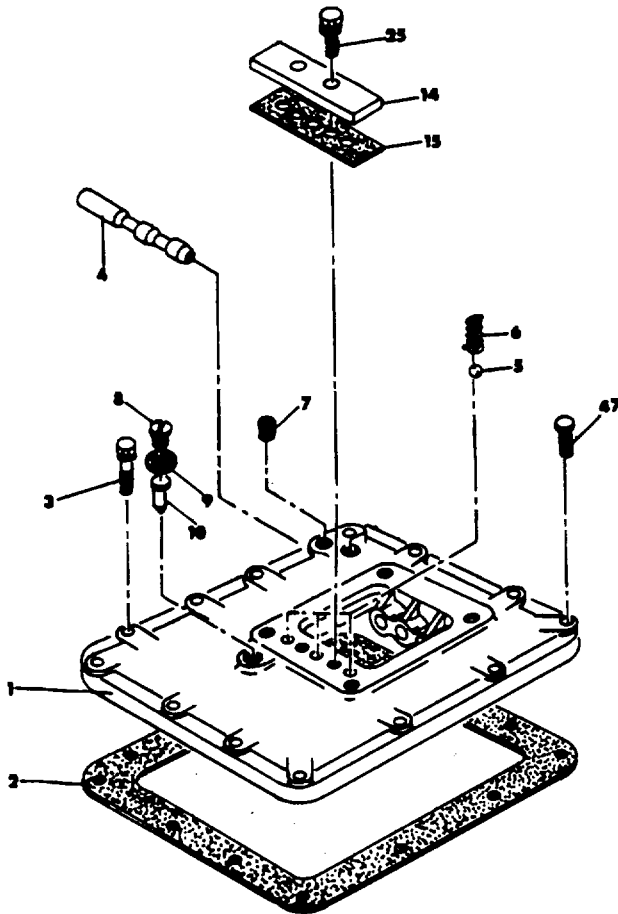
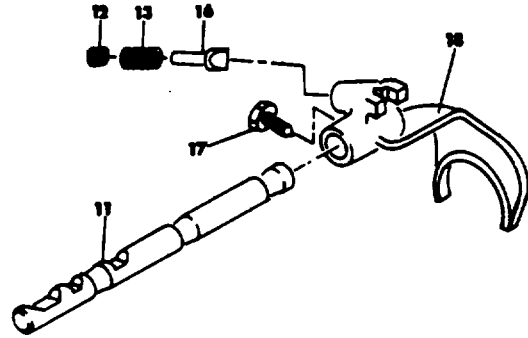
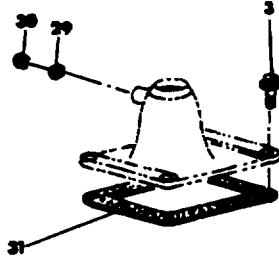

HOUSING ASSEMBLY

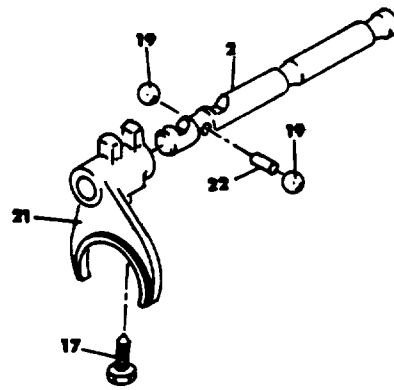

YOKES AND BARS ASSEMBLY

7-904-000078

Sheet 5 of 15

B-12

REF. NO.	PART NUMBER	DESCRIPTION	NO. REQ'D
		YOKES AND BARS ASSEMBLY	
1	9-904-103209	Shift Bar Housing -----	1
2	9-904-102080	Gasket-----	1
3	9-904-101267	Capscrew -----	14
4	9-904-102888	Air Valve Shaft-----	1
5	9-904-101261	Steel Ball-----	3
6	9-904-101262	Spring-----	3
7	9-904-102063	Pipe Plug-----	1
8	9-904-101892	Plug -----	1
9	9-904-101893	Gasket-----	1
10	9-904-102081	Pin-----	1
11	9-904-102054	Yoke Bar - Reverse -----	1
12	9-904-101895	Plug -----	1
13	9-904-102053	Spring-----	1
14	9-904-102078	Spring Cover-----	1
15	9-904-102079	Gasket-----	1
16	9-904-101898	Plunger-----	1
17	9-904-101263	Lockwasher -----	3
18	9-904-102055	Shift Yoke - Reverse -----	1
19	9-904-101878	Steel Ball-----	2
20	9-904-102056	Yoke Bar - 2nd Speed -----	1
21	9-904-102057	Shift Yoke - 2nd Speed-----	1
22	9-904-101720	Pin-----	1
23	9-904-102058	Shift Yoke - Direct -----	1
24	9-904-102059	Yoke Bar - Direct-----	1
25	9-904-101813	Capscrew -----	2
29	9-904-101861	Lockwasher -----	1
30	9-904-101862	Nut-----	1
31	9-904-101794	Gasket-----	1
47	9-904-101745	Capscrew -----	1

7-904-000078

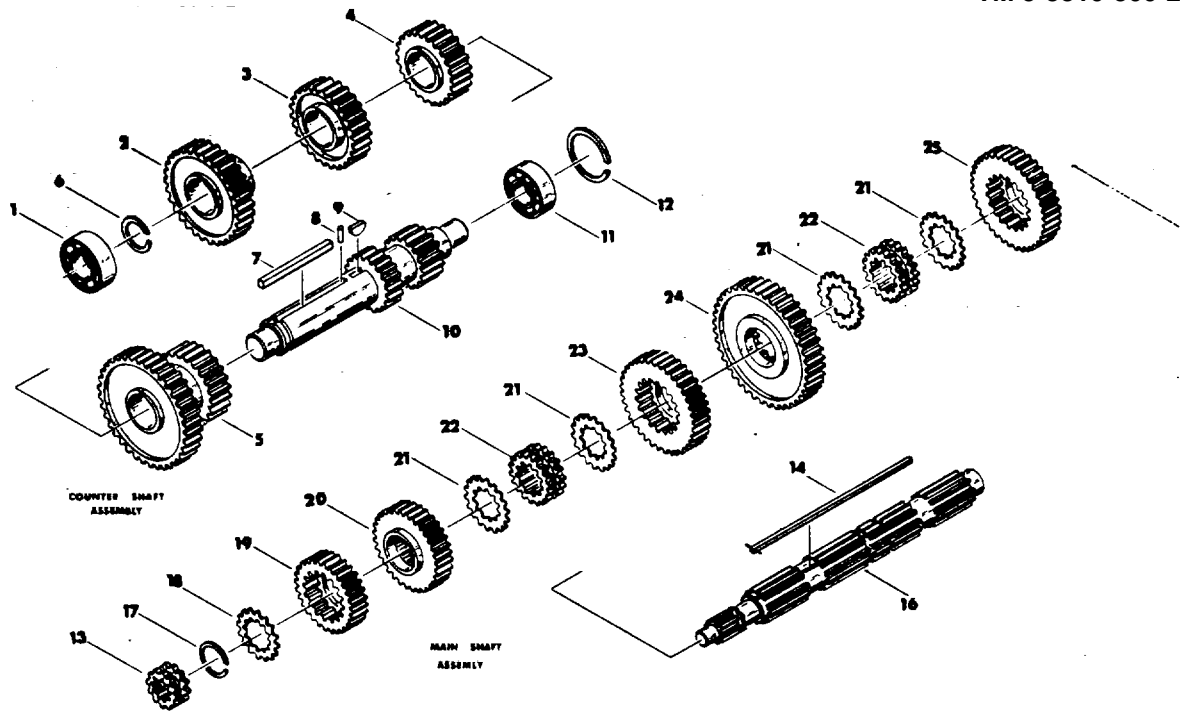

REF. NO.	PART NUMBER	DESCRIPTION	NO. REQ'D
MAIN SHAFT - COUNTERSHAFT			
1	9-904-101964	Bearing, C/S Front-----	2
2	9-904-101924	Gear, C/S D/G-----	2
3	9-904-103373	Gear, C/S 4th -----	2
4	9-904-101919	Gear, C/S 3rd-----	2
5	9-904-101977	Gear, C/S 2nd & P.T.O-----	2
6	9-904-101932	Snap Ring -----	2
7	9-904-101928	Key -----	2
8	9-904-101920	Rod/Pin-----	2
9	9-904-101978	Key -----	2
10	9-904-101979	Countershaft -----	2
11	9-904-101940	Bearing, C/S Rear -----	2
12	9-904-101938	Snap Ring -----	2
13	9-904-103374	Sliding Clutch -----	1
14	9-904-102129	Key & Pin Assembly-----	1
15	9-904-101975	Mainshaft -----	1
17	9-904-101926	Snap Ring -----	1
18	9-904-101925	Washer, .259 - .261 -----	1
	9-904-103375	Washer, .263 - .265 -----	1
	9-904-103376	Washer, .268 - .270 -----	1
	9-904-103377	Washer, .273 - .275 -----	1
	9-904-103378	Washer, .278 - .280 -----	1
19	9-904-103379	Gear M/S O/D -----	1
20	9-904-101922	Gear M/S 3rd -----	1
21	9-904-101921	Washer, .259 - .261 -----	4
	9-904-103380	Washer, .264 - .266 -----	4

REF. NO.	PART NUMBER	DESCRIPTION	NO. REQ'D
		MAIN SHAFT - COUNTERSHAFT	
	9-904-103381	Washer, .269 - .271 -----	4
	9-904-103382	Washer, .274 - .276 -----	4
	9-904-103383	Washer, .279 - .281 -----	4
22	9-904-102032	Sliding Clutch -----	2
23	9-904-102035	Gear, M/S, 2nd -----	1
24	9-904-102034	Gear, M/S, 1st -----	1
25	9-904-102031	Gear, M/S, Reverse -----	1
			7-904-000078

Sheet 8 OF 15

B-15

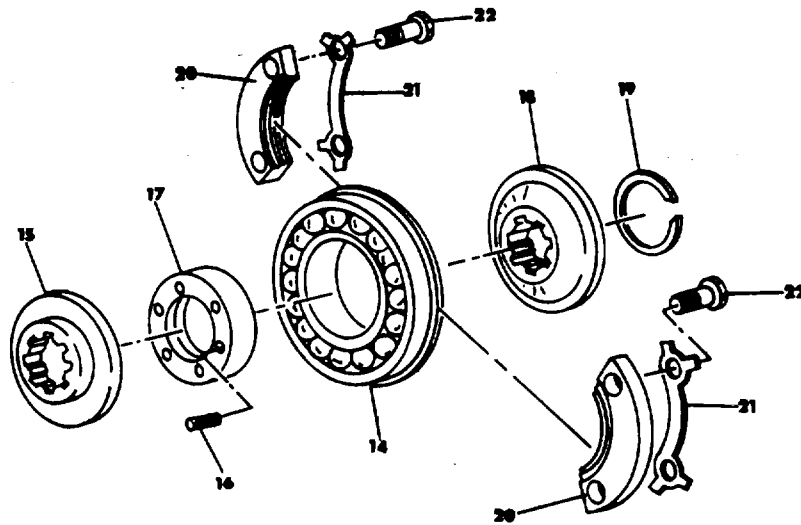

MAIN SHAFT BEARING ASSEMBLY

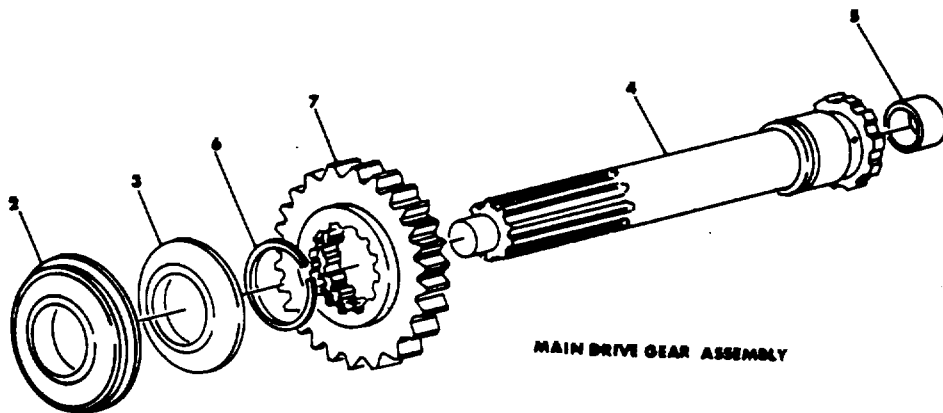

MAIN DRIVE GEAR ASSEMBLY

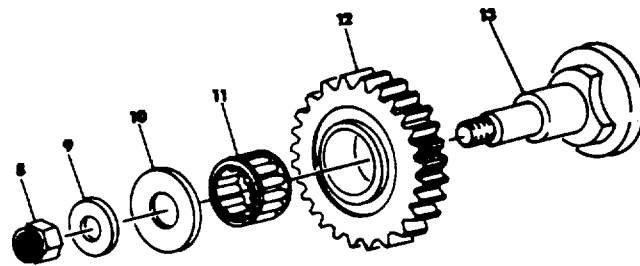

IDLER GEAR ASSEMBLY

REF. NO.	PART NUMBER	DESCRIPTION	NO. REQ'D
MAIN DRIVE, IDLER, BEARING ASSEMBLY			
2	9-904-101965	Bearing-----	1
3	9-904-101972	Spacer-----	1
4	Purchase Ass'y	Input Shaft-----	1
5	9-904-101974	Bushing-----	1
6	9-904-101973	Snap Ring-----	1
7	9-904-103385	Gear Main Drive-----	1
8	9-904-102042	Nut-----	2
9	9-904-102041	Washer-----	2
10	9-904-102038	Washer-----	2
11	9-904-102043	Bearing-----	2
12	9-904-102037	Gear, Idler-----	2
13	9-904-102124	Idler Shaft Kit-----	2
14	9-904-101941	Bearing-----	1
15	9-904-101980	Washer-----	1
16	9-904-101981	Spring-----	6
17	9-904-101982	Ring-----	1
18	9-904-101937	Retainer-----	1
19	9-904-101946	Snap Ring-----	1
20	9-904-101943	Retainer-----	2
21	9-904-101944	Lockwasher-----	2
22	9-904-101945	Capscrew-----	4
	9-904-103386	Input Shaft Assembly -(Consists of the Following)	
	9-904-103207	Snap Ring-----	1
	9-904-101974	Bushing-----	1
	Purchase Ass'y	Input Shaft-----	1

7-904-000078

Sheet 10 OF 15

B-17

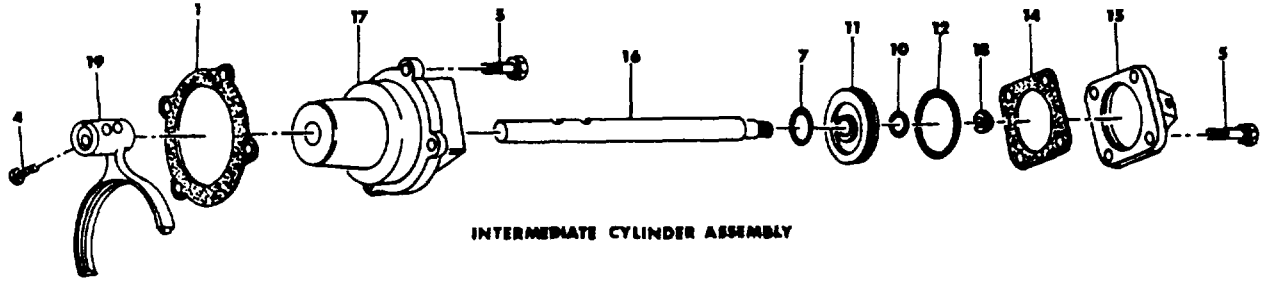
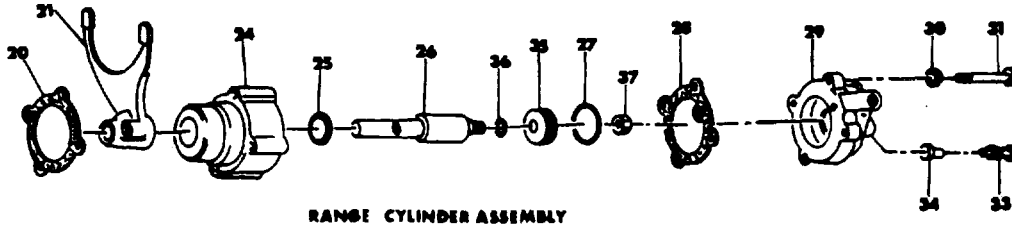

REF. NO.	PART NUMBER	DESCRIPTION	NO. REQ'D
CYLINDER ASSEMBLY			
1	9-904-102016	Gasket-----	1
4	9-904-102027	Bolt-----	2
5	9-904-101267	Capscrew-----	8
7	9-904-102013	"O" Ring-----	1
10	9-904-102011	"O" Ring-----	1
11	9-904-102012	Piston-----	1
12	9-904-102015	"O" Ring-----	1
14	9-904-102014	Gasket-----	1
15	9-904-102008	Cylinder Cover-----	1
16	9-904-102010	Yoke Bar-----	1
17	9-904-102017	Auxiliary Cylinder-----	1
18	9-904-102009	Nut-----	1
19	9-904-102022	Shift Yoke-----	1
20	9-904-101959	Gasket-----	1
21	9-904-101949	Shift Yoke-----	1
24	9-904-101960	Auxiliary Cylinder-----	1
25	9-904-101958	"O" Ring-----	1
26	9-904-103387	Yoke Bar-----	1
27	9-904-101983	"O" Ring-----	1
28	9-904-101961	Gasket-----	1
29	9-904-101989	Cylinder Cover-----	1
30	9-904-101861	Lockwasher-----	4
31	9-904-101993	Capscrew-----	4
33	9-904-101987	Plug-----	1

7-904-000078

REF. NO.	PART NUMBER	DESCRIPTION	NO. REQ'D
CYLINDER ASSEMBLY			
34	9-904-101988	Insert Valve-----	1
35	9-904-101984	Piston-----	1
36	9-904-103388	Gasket-----	1
37	9-904-101986	Nut-----	1
			7-904-000078

Sheet 12 OF 15

B-19

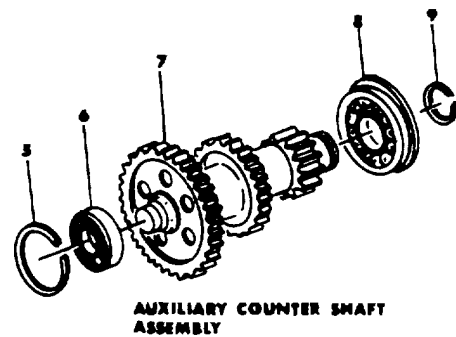
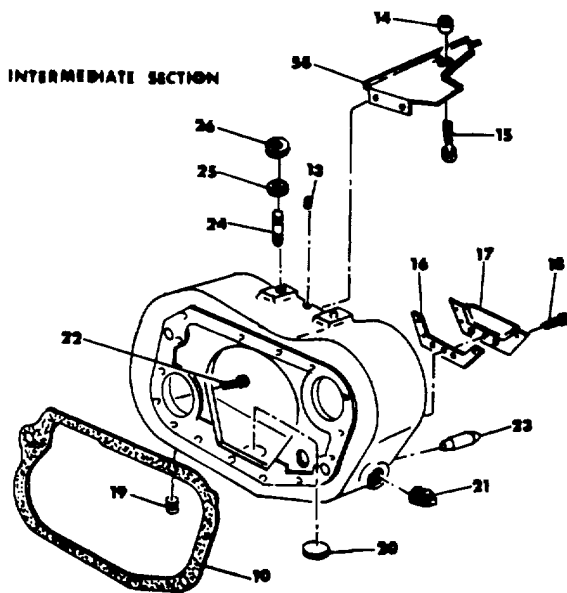
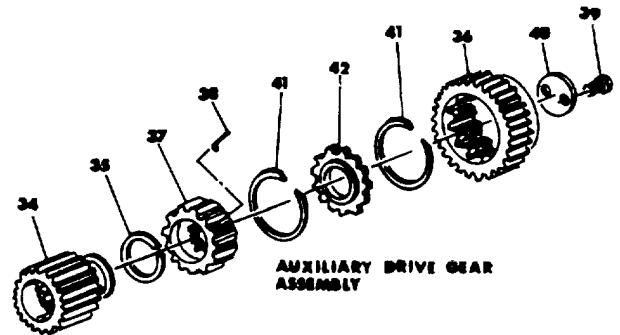
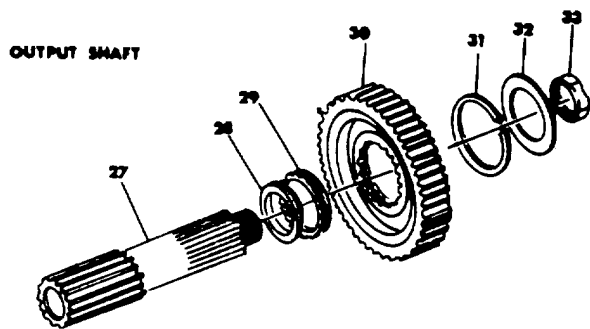
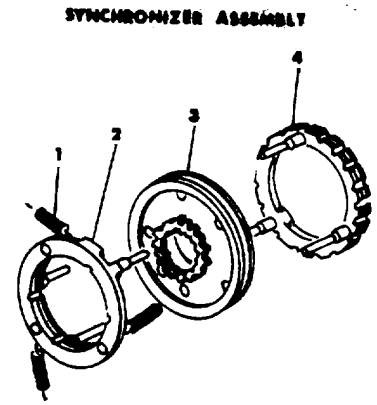
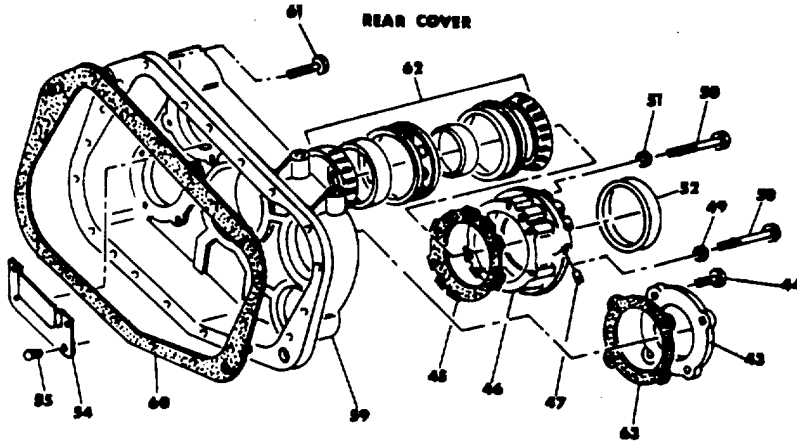

7-904-000078

REF. NO.	PART NUMBER	DESCRIPTION	NO. REQ'D
AUXILIARY ASSEMBLY			
1	9-904-102023	Spring-----	3
2	9-904-103389	Synchronizer High-----	1
3	9-904-101992	Sliding Clutch-----	1
4	9-904-102007	Synchronizer, Low-----	1
5	9-904-102036	Spacer-----	2
6	9-904-102049	Bearing-----	2
7	9-904-102044	C/S Assembly-----	2
8	9-904-102048	Bearing 2-----	2
9	9-904-102047	Snap Ring-----	2
10	9-904-102030	Gasket-----	1
11	9-904-101947	Case Housing-----	1
13	9-904-102100	Plug-----	1
14	9-904-102101	Spacer-----	1
15	9-904-102102	Capscrew-----	1
16	9-904-102086	Gasket-----	1
17	9-904-102088	Oil Reservoir Plate-----	1
18	9-904-102087	Drive Screw-----	4
19	9-904-102085	Pipe Plug-----	1
20	9-904-102084	Magnet-----	1
21	9-904-101887	Pipe Plug-----	1
22	9-904-102029	Capscrew 1 3/4"-----	4
	9-904-101942	Capscrew 1 1/2"-----	11
23	9-904-101939	Dowel-----	2
24	9-904-102099	Stud-----	2
25	9-904-101828	Lockwasher-----	2
26	9-904-101827	Nut-----	2
27	9-904-102001	Main Shaft-----	1
28	9-904-101997	Washer-----	1
29	9-904-101996	Spacer-----	1
30	9-904-101991	Gear, M/S, Low-----	1
31	9-904-101994	Snap Ring-----	1
32	9-904-101995	Washer-----	1
33	9-904-102002	Nut-----	1
34	9-904-101948	Gear, Auxiliary Drive-----	1
35	9-904-101950	Snap Ring-----	1
36	9-904-101951	Gear Mainshaft-----	1
37	9-904-101952	Sliding Clutch-----	1
38	9-904-102028	Retainer-----	1
39	9-904-102020	Bolt-----	2
40	9-904-102019	Retainer-----	1
41	9-904-102024	Snap Ring-----	2
42	9-904-102026	Washer-----	1
43	9-904-102046	Rear Bearing Cover-----	2
44	9-904-101813	Capscrew-----	8
45	9-904-102004	Gasket-----	1
46	9-904-101998	Rear Bearing Cover-----	1
47	9-904-101886	Bushing-----	1
49	9-904-102918	Gasket-----	1
50	9-904-101999	Capscrew-----	5
	9-904-102933	Capscrew-----	1
51	9-904-101256	Lockwasher-----	5

REF. NO.	PART NUMBER	DESCRIPTION	NO. REQ'D
AUXILIARY ASSEMBLY			
52	9-904-102003	Oil Seal-----	1
54	9-904-103211	Oil Reservoir Plate-----	1
55	9-904-103210	Drive Screw -----	4
58	9-904-103212	Oil Trough -----	1
59	9-904-102018	Rear Housing -----	1
60	9-904-102025	Gasket-----	1
61	9-904-101745	Capscrew -----	17
	9-904-101256	Lockwasher -----	2
	9-904-102021	Capscrew -----	2
62	9-904-102000	Bearing-----	1
63	9-904-102045	Gasket-----	2
64	9-904-103425	Sleeve, Speedo (Not Shown) -----	1
65	9-904-102146	Gear, Speedo - Drive (Not Shown)-----	1
66	9-904-102147	Gear, Speedo - Driven (Not Shown) -----	1

7-904-000078

Sheet 15 OF 15

B-22

**ADDENDUM B
PARTS CATALOG
(CARRIER)**

AXLE GROUP



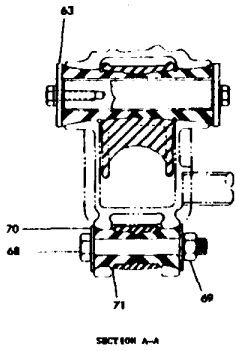
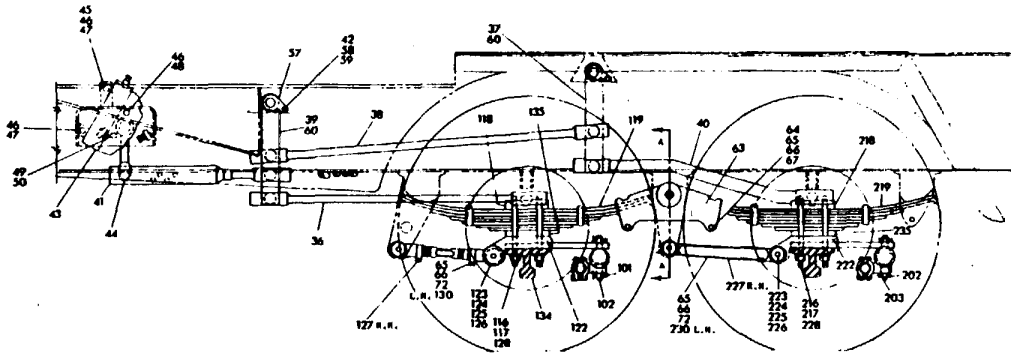

ITEMS NOT SHOWN:
75 AIR SYSTEMS SCHEMATIC

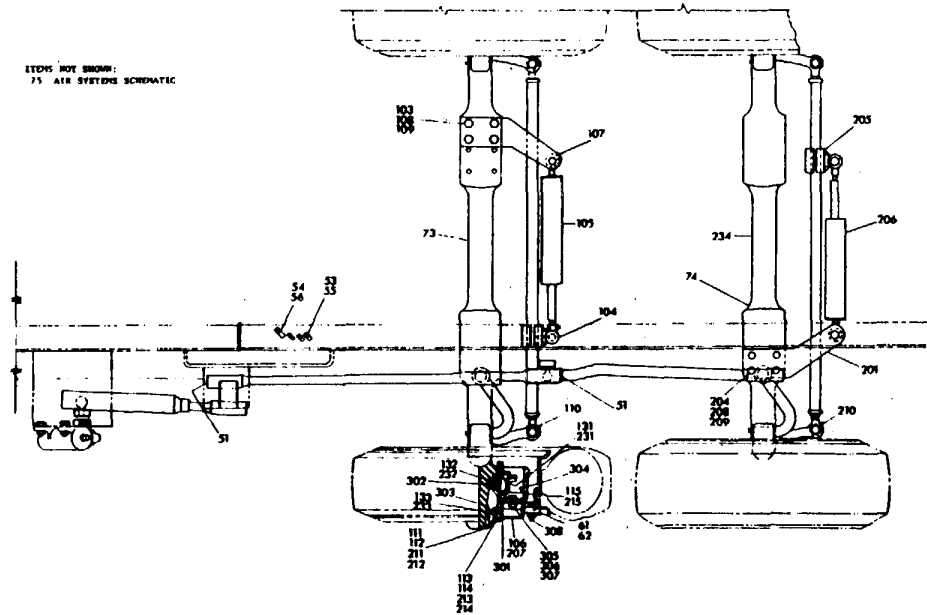

6-049-000239

REF. NO.	PART NUMBER	DESCRIPTION	NO. REQ'D
FRONT AXLE & STEERING ASSEMBLY & INSTALLATION WITH GARRISON DRAG LINKS			
36	7-601-000054	Drag Link Assembly	1
37	6-033-000159	Relay Arm Assembly	1
38	7-601-000052	Drag Link	1
39	6-033-000160	Relay Arm Assembly	1
40	7-601-000078	Drag Link Assembly-	1
41	7-601-000071	Drag Link & Control Valve	1
42	MS35338-46	Lockwasher - 3/8" Medium - Spring Steel	2
43	7-490-000037	Steering Gear Assembly	1
44	7-033-000092	Arm, Pitman.....	1
45	MS90725-164	Bolt, Hex Head - 5/8"-11 N.C. x 2" Length - Grade 1	1
46	MS35338-50	Lockwasher - 5/8" Medium - Spring Steel-----	4
47	MS51967-20	Nut, Hex - 5/8"-11 N.C. - Grade A.....	2
48	MS90725-162	Bolt, Hex Head - 5/8"-11 N.C. x 1 1/2" Length - Grade 1-	2
49	MS90725-115	Bolt, Hex Head - 1/2"-13 N.C. x 2" Length - Grade 1	2
50	MS35691-33	Nut, Jam- 1/2"-13 N.C. - Grade A.....	2
51	MS15003-2	Fititng, Grease - 1/8" N.P.T. Straight Ball Check.....	A/R
53	7-300-000102	Clamp, Tubing.....	3
54	7-300-000104	Clamp, Tubing.....	1
55	7-790-140853	Screw, Hex Washer Head Self-Tapping - 1/4"-20 N.C. x 1/2" Length.....	3
56	7-790-160853	Screw, Hex Washer Head. Self-Tapping - 3/8"-16 N.C. x 1/2" Length.....	1
57	6-810-001149	Shaft Weldment	2
58	MS90725-62	Bolt, Hex Head - 3/8"-16 N.C. x 1 1/4" Length - Grade 1	2
59	MS51967-8	Nut, Hex - 3/8"-16 N.C. - Grade A.....	2
60	6-207-242412	Bushing	4
61	7-300-000145	Clamp, Rim	24
62	7-660-221318	Nut, Heavy Hex.....	24
63	7-576-000295	Suspension Assembly Kit.....	2
64	7-099-000274	Capscrew--	6
65	7-659-000146	Nut, Hex-.....	8
66	7-949-000276	Lockwasher-.....	8
67	7-772-000101	Roller, Spring	6
68	7-099-000277	Bolt, Torque Arm	4
69	7-659-000147	Locknut.....	4
70	7-949-000277	Washer, Torque Arm Compression	8
71	7-199-001115	Bushing, Torque Arm	8
72	7-099-000276	Capscrew.....	2
75	2-147-6-00071	Air Syste Schematic - Front Axle - Not Shown	1

REF. NO.	PART NUMBER	DESCRIPTION	NO. REQ'D
FRONT AXLE & STEERING ASSEMBLY & INSTALLATION WITH GARRISON DRAG LINKS			
101		Pin, Cotter - 1/8" Diameter x 2" Length	2
102	7-826-000016	Socket, Vertical-----	2
103	MS35338-51	Lockwasher - 3/4" Medium - Spring Steel	4
104	7-300-000089	Clamp, Tie Rod-	1
105	7-372-000872	Cylinder, Steer	1
106	7-970-000366	Wheel & Drum Assembly-----	2
		(Consists of Items 301 Thru 308)	
107	2-137-1-00072	R.H. Support Weldment	1
108	MS90726-191	Bolt, Hex Head - 3/4"-16 N.F. x 3" Length - Grade 54	4
109	MS51968-23	Nut, Hex - 3/4"-16 N.F. - Grade A	4
110	MS15003-2	Fitting, Grease - 1/8" N.P.T. Straight Ball Check- --	6
111	7-794-000411	Gasket-----	2
112	7-258-000356	Cap, Hub	2
113	MS90725-31	Bolt, Hex Head - 5/16"-18 N.C. x 5/8" Length - Grade 1	12
114	MS35338-45	Lockwasher - 5/16" Medium - Spring Steel	12
115		Not Required	
116	7-659-000145	Nut, High Self-Locking	8
117	7-949-000275	Flatwasher	8
118	7-705-006341	Plate, Top U-Bolt.....	2
119	7-834-000122	Spring	2
122	7-798-000039	Seat, Axle2-.....	2
123	7-099-000277	Bolt, Torque Arm	2
124	7-659-000147	Locknut.....	2
125	7-949-000277	Washer, Torque Arm Compression	4
126	7-199-001115	Bushing, Torque Arm- --	4
127	7-033-000178	Torque Arm Rigid Front-.....	1
128	7-099-000275	U-Bolt	4
130	7-033-000180	Torque Arm Adjusting Assembly - Front-----	1
131	7-794-000429	Seal, Wheel Bearing Oil.....	2
132	7-069-000268	Cone, Inner Bearing-	2
133	7-069-000269	Cone, Outer Bearing.....	2
134	7-049-000209	Front Axle	1
135	7-910-003333	Spacer.....	2

6-049-000239 (C)

Sheet 2 of 4

B-26

REF. NO.	PART NUMBER	DESCRIPTION	NO. REQ'D
FRONT AXLE & STEERING ASSEMBLY & INSTALLATION WITH GARRISON DRAG LINKS			
201	2-137-1-00071	L.H. Support Weldment.....	1
202		Pin, Cotter - 1/8" Diameter x 2" Length	2
203	7-826-000016	Socket, Vertical.....	2
204	MS35338-51	Lockwasher - 3/4" Medium - Spring Steel	4
205	7-300-000089	Clamp, Tie Rod	1
206	7-372-000872	Cylinder, Steer	1
207	7-970-000366	Wheel & Drum Assembly	2
(Consists of Items 301 Thru 308)			
208	MS90726-191	Bolt, Hex Head - 3/4"-16 N.F. x 3" Length - Grade 5-	4
209	MS51968-23	Nut, Hex - 3/4"-16 N.F. - Grade A.....	4
210	MS15003-2	Fitting, Grease - 1/8" N.P.T. Straight Ball Check.....	6
211	7-794-000411	Gasket.....	2
212	7-258-000356	Cap, Hub.....	2
213	MS90725-31	Bolt, Hex Head - 5/16"-18 N.C. x 5/8" Length - Grade 1	12
214	MS35338-45	Lockwasher - 5/16" Medium - Spring ---	12
215		Not Required	
216	7-659-000145	Nut, High Self-Locking	8
217	7-949-000275	Flatwasher	8
218	7-705-006341	Plate, Top U-Bolt-----	2
219	7-834-000122	Spring	2
222	7-798-000039	Seat, Axle.....	2
223	7-099-000277	Bolt, Torque Arm	2
224	7-659-000147	Locknut.....	2
225	7-949-000277	Washer, Torque Arm Compression	4
226	7-199-001115	Bushing, Torque Arm	4
227	7-033-000179	Torque Arm Rigid Rear	1
228	7-099-000275	U-Bolt	4
230	7-033-000181	Torque Arm Adjusting Assembly - Rear.....	1
231	7-794-000429	Seal, Wheel Bearing Oil- -----	2
232	7-069-000268	Cone, Inner Bearing.....	2
233	7-069-000269	Cone, Outer Bearing.....	2
234	7-049-000210	Rear Axle	1
235	7-910-003333	Spacer.....	2
301	9-049-103406	Spider, Wheel.....	1 per Wheel
302	9-049-103407	Cup, Inner Bearing.....	1 per Wheel
303	9-049-102826	Cup, Outer Bearing.....	1 per Wheel
304	9-049-103409	Drum, Brake	1 per Wheel
305	9-049-103410	Bolt, Drum	6 per Wheel
306	9-049-103411	Flatwasher-----	12 per Wheel
307	9-049-103412	Locknut.....	6 per Wheel
308	9-049-103413	Stud, Rim	6 per Wheel

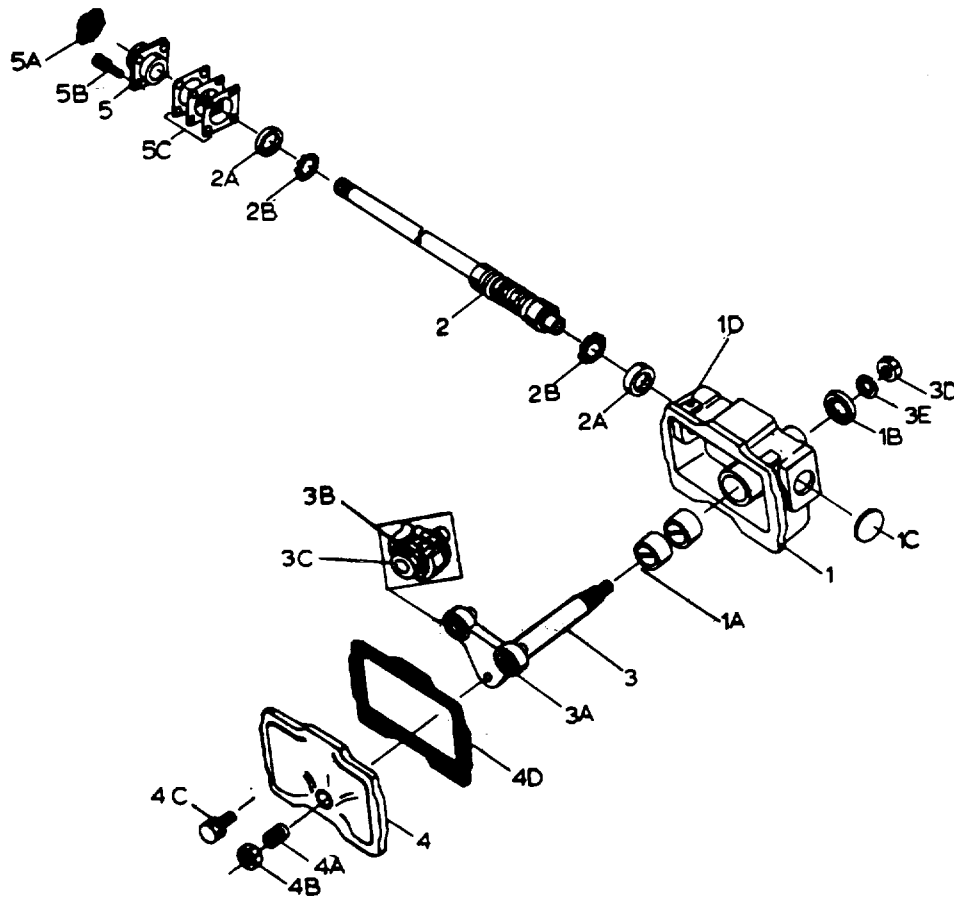

REF. NO.	PART NUMBER	DESCRIPTION	NO. REQ'D
		STEERING GEAR ASSEMBLY	
	7-490-000037	Steering Gear Assembly	
		<u>HOUSING GROUP</u>	
	9-490-100085	Housing Service Assembly (Includes Items #1, #1A, #1B, #1C & #1D)	1
1	N.S.S	Housing	1
1A	9-490-100005	Bushing	2
1B	9-490-100006	Seal, Oil.....	1
1C	9-490-100007	Plug	1
1D	9-490-100008	Plug, Vent	1

7-490-000037

REF. NO.	PART NUMBER	DESCRIPTION	NO. REQ'D
STEERING GEAR ASSEMBLY			
<u>CAM GROUP</u>			
	9-490-100086	Cam Service Assembly (Includes Items #2, #2A & #2B)	1
	9-490-100087	Cam Bearing Kit --	1
2	N.S.S	Cam	1
2A	N.S.S	Cup, Ball	2
2B	9-490-100011	Retainer Assembly.....	2
<u>LEVERSHAFT GROUP</u>			
	9-490-100088	Levershaft Service Assembly (Includes Items #3, #3A, #3B, #3C, #3D & #3E)	1
3	N.S.S	Levershaft	1
3A	9-490-100013	Bearing Assembly	Matched Pair
3B	9-490-100091	Washer, Star.....	1
3C	9-490-100092	Nut 1/2"-20.....	1
3D	9-490-100014	Nut 1 1/8"-12.....	1
3E	9-490-100015	Washer, Lock 1 1/8" Medium.....	1
<u>SIDE COVER GROUP</u>			
	9-490-100089	Side Cover Service Assembly (Includes Items #4, #4A, #4B, #4C & #4D)	1
4	9-490-100016	Cover, Side	1
4A	9-490-100017	Screw, Adjusting.....	1
4B	9-490-100018	Nut 1/2"-20.....	1
4C	9-490-100019	Screw 3/8"-16 x 1 1/2".....	6
4D	9-490-100020	Gasket -.....	1
<u>UPPER COVER GROUP</u>			
	9-490-100090	Upper Cover Service Assembly (Includes Items #5, #5A, #5B & #5C)	1
5	N.S.S	Cover, Upper	1
5A	9-490-100022	Seal, Oil.....	1
5B	9-490-100023	Screw, 3/8"-16 x 1 1/4" -a -	4
5C	9-490-100024	Shim - (.002)	3
	9-490-100025	Shim - (.003)	3
	9-490-100026	Shim - (.010)	3
	N.S.S - Not Sold Separately		

7-490-000037

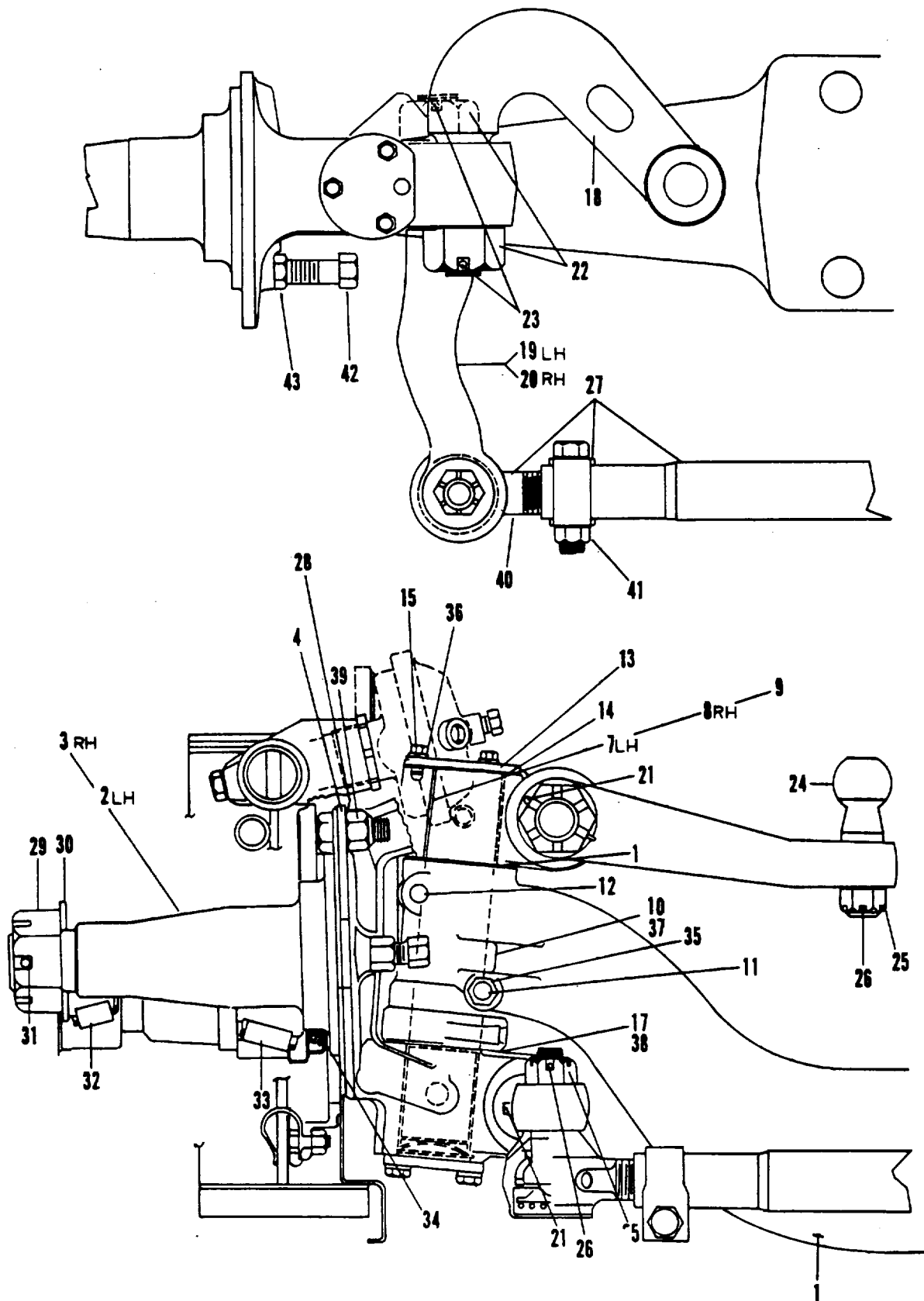

Sheet 1 of 4

7-049-000209

B-30

REF. NO.	PART NUMBER	DESCRIPTION	NO. REQ'D
	7-049-000209	Front Axle Assembly	
1	9-049-104179	Axle Center	1
2	9-049-103347	Steering Knuckle & Brake Assembly - L.H.....	1
3	9-049-103348	Steering Knuckle & Brake Assembly - R.H.	1
4	9-049-103349	Steering Knuckle & Dust Shield Bolt.....	1
7	9-049-103352	Steering Knuckle & Bushing Assembly - L.H.--.....	1
8	9-049-103353	Steering Knuckle & Bushing Assembly - R.H.....	1
9	9-049-103354	Bushing, Bronze	4
10	9-049-103355	Pin, Steering Knuckle.....	2
11	9-049-103356	Key, Draw - Lower	2
12	9-049-103357	Key, Draw - Upper	2
13	9-049-103358	Cap, Dust.....	4
14	9-049-103359	Gasket, Dust Cap	4
15	9-049-104180	Screw, Dust Cap	12
16	9-049-101794	Shim	2
16A	9-049-102569	Shim, Steering Knuckle.....	2
16B	9-049-101796	Shim - .010.....	2
16C	9-049-101795	Shim - .005.....	2
17	9-049-101802	Bearing, Thrust	2
18	9-049-103361	Arm, Steering	1
19	9-049-101811	Arm, Steering Cross-Tube - L.H.-----	1
20	9-049-101810	Arm, Steering Cross-Tube - R.H.....	1
21	9-049-101805	Key, Steering Cross-Tube.....	3
22	9-049-101806	Nut, Steering Cross-Tube	3
23	9-049-101807	Cotter, Steering Cross-Tube.....	3
24	9-049-104181	Ball - 1 3/4	1
25	9-049-104182	Nut, Steering Arm	1
26	9-049-101682	Cotter, Steering Arm-	3
27	9-049-103362	Cross-Tube & End Assembly	1
28	9-049-103828	Washer, Dust Shield	14
29	9-049-101835	Nut, Wheel Bearing.....	2
30	9-049-101836	Washer, Wheel Bearing.....	2
31	9-049-102572	Cotter, Wheel Bearing	2
32	7-069-000269	Cone, Outer	2
33	7-069-000268	Cone, Inner	2
34	7-974-000429	Oil Seal Assembly - Wheel Bearing	2
35	9-049-103365	Nut, Draw Key	4
36	9-188-100209	Lockwasher, Dust Cap.....	12
37	9-049-103367	Seal, Steering Knuckle.....	4
38	9-049-103368	Seal, Thrust Bearing.....	2
39	9-049-103369	Steering Knuckle & Dust Shield Nut.....	14
40	9-049-104185	Tie Rod End - L.H.....	1
40A	9-049-104186	Tie Rod End - R.H	1
41	9-049-101813	Clamp.....	2
41A	9-049-101814	Bolt.....	2
41B	9-049-101815	Nut.....	2
42	9-049-104183	Stopscrew.....	2
43	9-049-103001	Nut.....	2

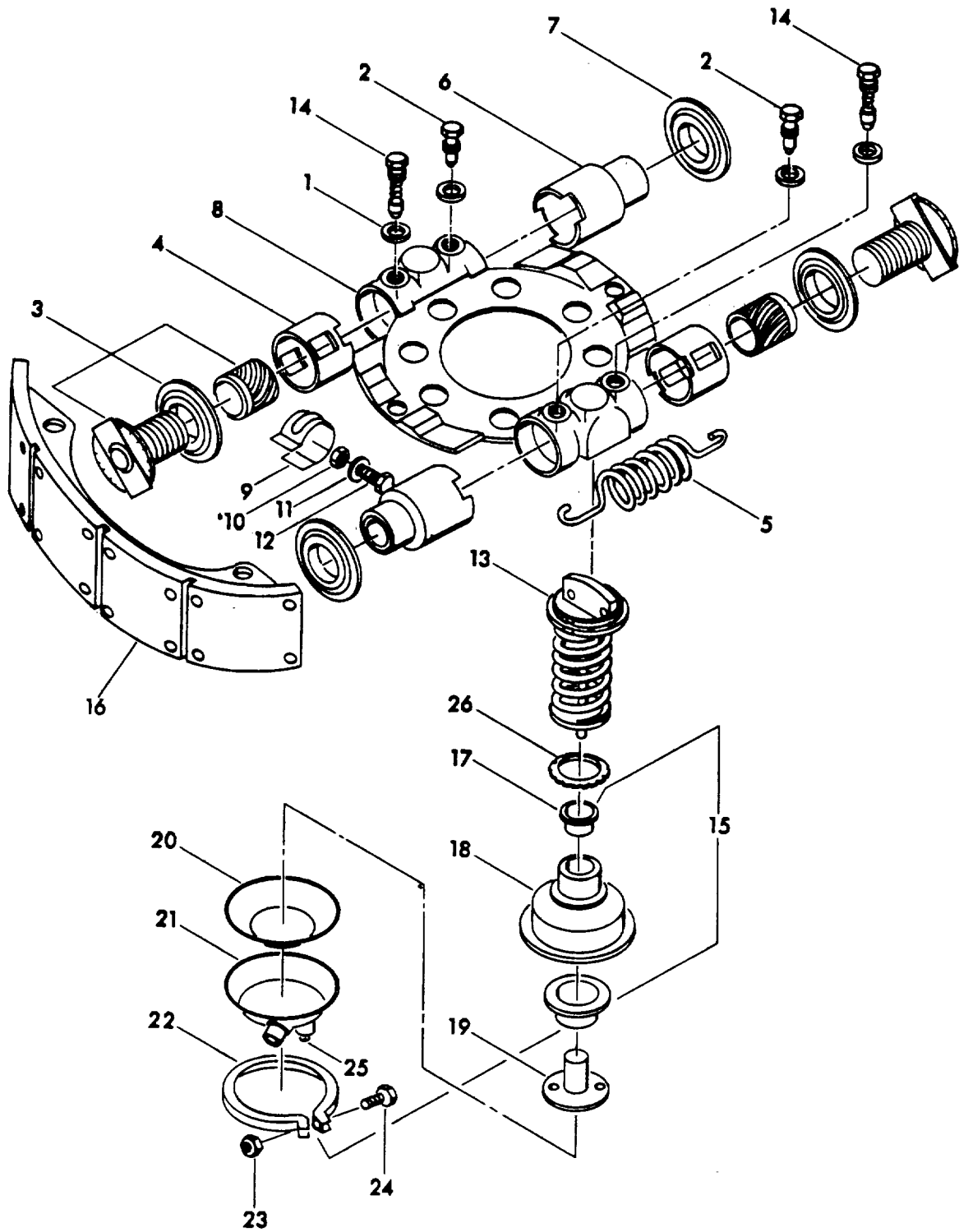

7-049-000209

REF. NO.	PART NUMBER	DESCRIPTION	NO. REQ'D
COMPLETE BRAKE ASSEMBLY			
1	9-049-101717	Washer-.....	4
2	9-049-101720	Guide-	2
3	9-049-103175	Actuator Assembly	2
4	9-049-103174	Plunger, Adjusting.....	2
5	9-049-101822	Spring, Return-.....	2
6	9-049-101722	Plunger, Anchor - L.H.....	2
6A	9-049-101723	Plunger, Anchor - R.H.	2
7	9-049-101713	Retainer Assembly	2
8	9-049-103370	Brake Spider Assembly - L.H.....	1
		(Includes Items 9, 10, 11 & 12)	
	9-049-103371	Brake Spider Assembly - R.H.	1
		(Includes Items 9, 10, 11 & 12)	
9	9-049-101709	Clip, Hold Down	2
10	9-049-102550	Nut, Hold Down Clip	2
11	9-049-101712	Washer, Hold Down Clip	2
12	9-049-101710	Capscrew, Hold Down Clip	2
13	9-049-101724	Wedge Assembly	2
14	9-049-103177	Guide Assembly.....	2
15	9-049-104184	Chamber Assembly	2
		(Consists of Items 17 thru 25)	
16	9-049-103373	Shoe Assembly	2
17	9-049-101731	Guide.....	2
18	9-049-104188	Non-Pressure Housing Assembly.....	2
19	9-049-104187	Diaphragm Plate Assembly	2
20	9-049-103376	Diaphragm	2
21	9-049-103377	Pressure Housing Assembly.....	2
22	9-049-103378	Ring, Clamp.....	2
23	9-049-104093	Nut.....	2
24	9-049-101758	Bolt.....	2
25	9-049-103379	Plug	2
26	9-049-101760	Nut, Collet.....	2

ITEMS NOT ILLUSTRATED

9-049-103380	Shield, Dust.....	2
9-049-101762	Lockwasher, Dust Shield	4
9-722-100511	Capscrew, Dust Shield	4
9-049-104189	Brake Lining & Rivet Kit.....	1
	(Contains Lining & Rivets for 2 Wheels)	
9-049-101763	Plug, Rubber - Dust Shield	4
9-049-104090	Plug, Rubber - Dust Shield	2

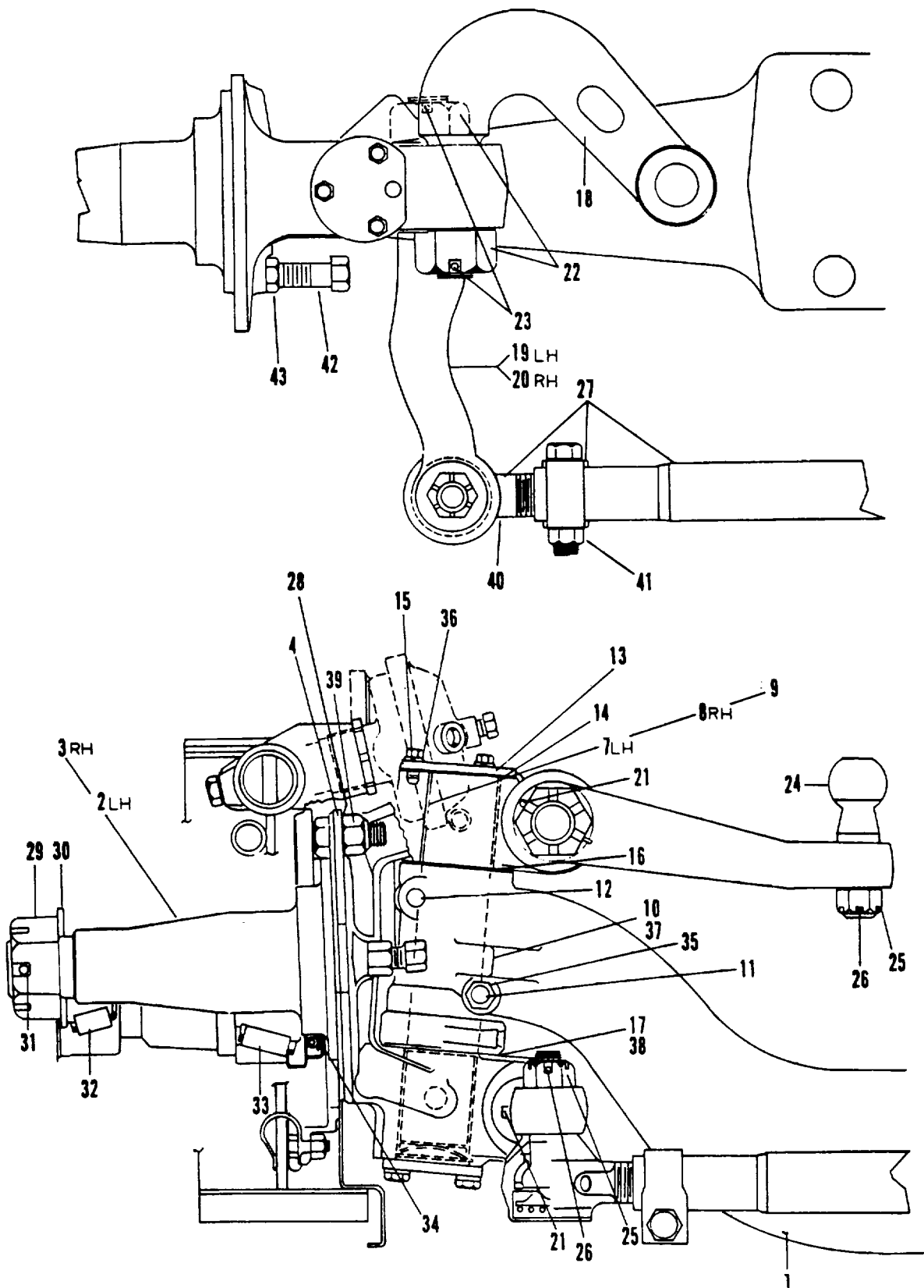

Sheet 1 of 4

7-049-000210

B-34

REF. NO.	PART NUMBER	DESCRIPTION	NO. REQ'D
COMPLETE FRONT AXLE ASSEMBLY			
	7-049-000210	Front Axle Assembly	
1	9-049-103346	Axle Center	1
2	9-049-103347	Steering Knuckle & Brake Assembly - L.H.....	1
3	9-049-103348	Steering Knuckle & Brake Assembly - R.H	1
4	9-049-103349	Steering Knuckle & Dust Shield Bolt.....	14
7	9-049-103352	Steering Knuckle & Bushing Assembly - L.H	1
8	9-049-103353	Steering Knuckle & Bushing Assembly - R.H.....	1
9	9-049-103354	Bushing, Bronze	4
10	9-049-103355	Pin, Steering Knuckle.....	2
11	9-049-103356	Key, Draw - Lower	2
12	9-049-103357	Key, Draw - Upper	2
13	9-049-103358	Cap, Dust.....	4
14	9-049-103359	Gasket, Dust Cap	4
15	9-049-104180	Screw, Dust Cap	12
16	9-049-101794	Shim.....	2
16A	9-049-102569	Shim, Steering Knuckle.....	2
16B	9-049-101796	Shim - .010.....	2
16C	9-049-101795	Shim - .005.....	2
17	9-049-101802	Bearing, Thrust	2
18	9-049-103361	Arm, Steering	1
19	9-049-101811	Arm, Steering Cross-Tube - L.H	1
20	9-049-101810	Arm, Steering Cross-Tube - R.H.....	1
21	9-049-101805	Key, Steering Cross-Tube.....	3
22	9-049-101806	Nut, Steering Cross-Tube	3
23	9-049-101807	Cotter, Steering Cross-Tube.....	3
24	9-049-104181	Ball - 1 3/4"	
25	9-049-104182	Nut, Steering Arm	1
26	9-049-101682	Cotter, Steering Arm.....	3
27	9-049-103362	Cross-Tube & End Assembly	1
28	9-049-103828	Washer, Dust Shield	
29	9-049-101835	Nut, Wheel Bearing.....	2
30	9-049-101836	Washer, Wheel Bearing-	2
31	9-049-102572	Cotter, Wheel Bearing	2
32	7-069-000269	Cone, Outer	2
33	7-069-000268	Cone, Inner	2
34	7-974-000429	Oil Seal Assembly - Wheel Bearing	2
35	9-049-103365	Nut, Draw Key	4
36	9-188-100209	Lockwasher, Dust Cap	12
37	9-049-103367	Seal, Steering Knuckle.....	4
38	9-049-103368	Seal, Thrust Bearing.....	2
39	9-049-103369	Steering Knuckle & Dust Shield Nut.....	14
40	9-049-104185	Tie Rod End - L.H.....	1
40A	9-049-104186	Tie Rod End - R.H	1
41	9-049-101813	Clamp.....	2
41A	9-049-101814	Bolt.....	2
41B	9-049-101815	Nut.....	2
42	9-049-104183	Stopscrew.....	2
43	9-049-103001	Nut.....	2

7-049-000210

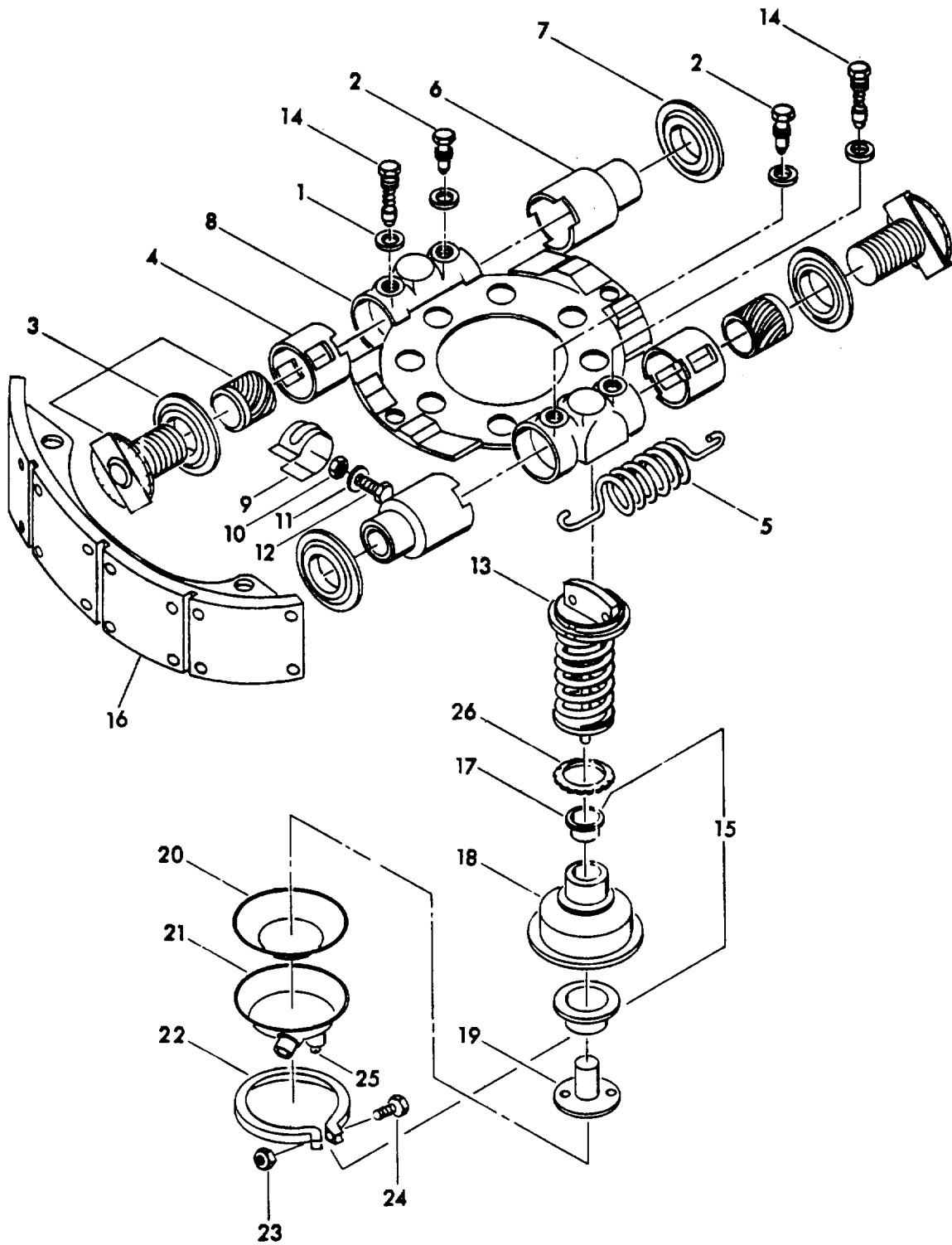

Sheet 3 of 4

7-049-000210

B-36

REF. NO.	PART NUMBER	DESCRIPTION	NO. REQ'D
COMPLETE BRAKE ASSEMBLY			
1	9-049-101717	Washer.....	4
2	9-049-101720	Guide.....	2
3	9-049-103175	Actuator Assembly.....	2
4	9-049-103174	Plunger, Adjusting.....	2
5	9-049-101822	Spring, Return.....	2
6	9-049-101722	Plunger, Anchor - L.H.....	2
6A	9-049-101723	Plunger, Anchor - R.H.....	2
7	9-049-101713	Retainer Assembly.....	2
8	9-049-103370	Brake Spider Assembly - L.H.....	1
		(Includes Items 9, 10, 11 & 12)	
	9-049-103371	Brake Spider Assembly - R.H.....	1
		(Includes Items 9, 10, 11 & 12)	
9	9-049-101709	Clip, Hold Down.....	2
10	9-049-102550	Nut, Hold Down Clip.....	2
11	9-049-101712	Washer, Hold Down Clip.....	2
12	9-049-101710	Capscrew, Hold Down Clip.....	2
13	9-049-101724	Wedge Assembly.....	2
14	9-049-103177	Guide Assembly.....	2
15	9-049-104184	Chamber Assembly.....	2
		(Consists of Items 17 thru 25)	
16	9-049-103373	Shoe Assembly.....	2
17	9-049-101731	Guide.....	2
18	9-049-104188	Non-Pressure Housing Assembly.....	2
19	9-049-104187	Diaphragm Plate Assembly.....	2
20	9-049-103376	Diaphragm.....	2
21	9-049-103377	Pressure Housing Assembly.....	2
22	9-049-103378	Ring, Clamp.....	2
23	9-049-104093	Nut.....	2
24	9-049-101758	Bolt.....	2
25	9-049-103379	Plug.....	2
26	9-049-101760	Nut, Collet.....	2

ITEMS NOT ILLUSTRATED

9-049-103380	Shield, Dust.....	2
9-049-101762	Lockwasher, Dust Shield.....	4
9-722-100511	Capscrew, Dust Shield.....	4
9-049-104189	Brake Lining & Rivet Kit.....	1
	(Contains Lining & Rivets for 2 Wheels)	
9-049-101763	Plug, Rubber - Dust Shield.....	4
9-049-104090	Plug, Rubber - Dust Shield.....	2

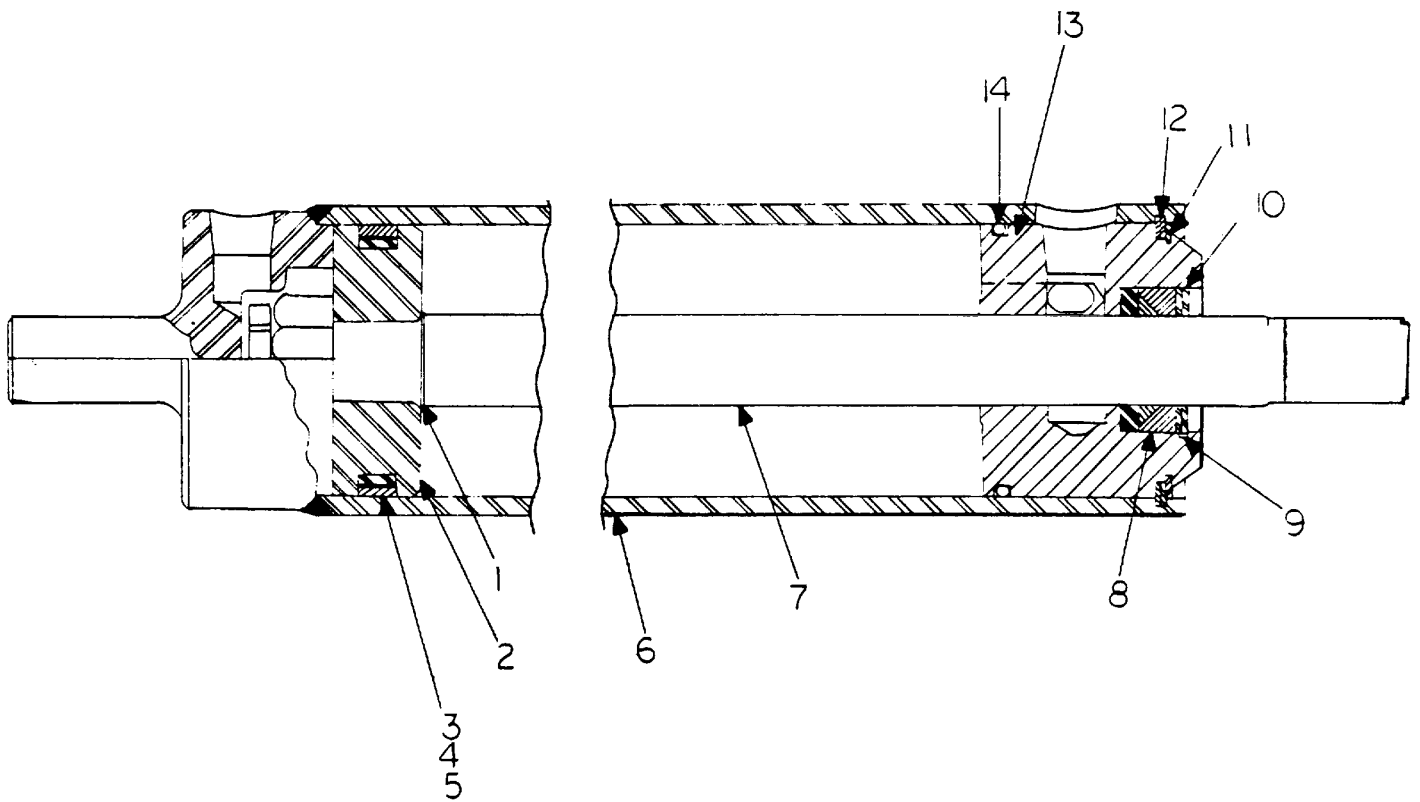

REF. NO.	PART NUMBER	DESCRIPTION	NO. REQ'D
		STEER CYLINDER ASSEMBLY	
	7-372-000872	Steer Cylinder Assembly	
* 1	9-372-100615	Seal	1
2	9-372-100652	Piston	1
* 3	9-372-100653	Ring, Piston	2
* 4	9-372-100654	Shim	1
* 5	9-372-100655	Seal	1
6	9-372-100656	Body	1
7	9-372-100657	Rod	1
* 8	9-372-100620	"D.W." Seal	1
9	9-372-100619	Washer	1
10	9-372-100621	Ring, Snap	1
11	9-372-100658	Ring, Snap	1
12	9-372-100659	Ring, Snap	1
13	9-372-100660	Head	1
* 14	9-372-100661	"O" Ring	1
	9-752-100135	Kit, Service	

*Items Included In Service Kit

7-372-000872

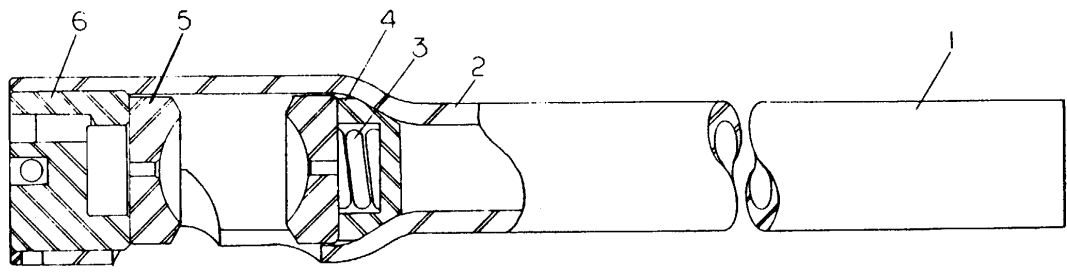

DRAG LINK

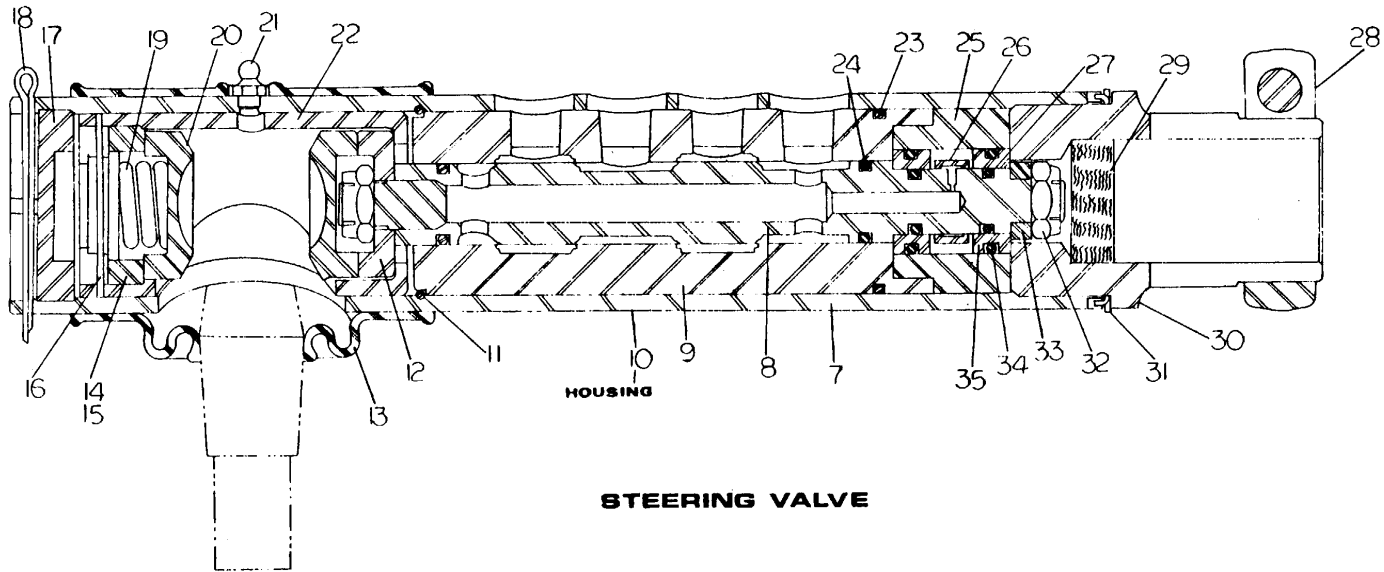

STEERING VALVE

7-601-000071

REF. NO.	PART NUMBER	DESCRIPTION	NO. REQ'D
DRAG LINK & STEERING VALVE ASSEMBLY			
	7-601-000071	Drag Link & Steering Valve Assembly	
1	9-926-101565	Drag Link Assembly (Includes Items #2, #3, #4, #5 and #6)	1
2	N.S.S.	Socket	1
3	9-926-101566	Spring	1
4	9-926-101567	Retainer	1
5	9-926-101568	Seat	2
6	9-926-101569	Plug, End	1
7	9-926-101570	Steering Valve Assembly (Includes Items #8 Thru #35)	1
8	9-926-101571	Piston.....	1
9	9-926-101333	Body.....	1
10	9-926-101335	Housing	1
11	9-926-101336	Ring, Retaining	1
12	9-926-101338	Bearing	1
13	9-926-101334	Shield, Dust.....	1
14	9-926-101341	Washer.....	1
15	9-926-101342	Plug, Socket.....	1
16	9-926-101343	Lock, Plug.....	1
17	9-926-101344	Plug, End.....	1
18		Pin, Cotter 1/8" x 3" - Steel	1
19	9-926-101340	Spring	1
20	9-926-101339	Seat, Ball.....	2
21	9-926-101345	Fitting, Lube	1
22	9-926-101337	Socket.....	1
23	9-926-101572	"0" Ring	1
*24	9-926-101332	"0" Ring	2
25	9-926-101329	Gland.....	1
26	9-926-101328	Spacer.....	1
*27	9-926-101330	"0" Ring	2
28	9-926-101321	Clamp.....	1
		(Consists of the Following Items)	
	MS90726-118	Screw, Cap 1/2"-20 x 2 3/4" - Grade 5.....	1
	MS35338-48	Lockwasher 1/2" Medium - Spring Steel	1
	MS51968-14	Nut, Hex 1/2"-20 - Grade A	1
29	9-926-101573	Plug, Felt.....	1
30	9-926-101322	Adapter	1
*31	9-926-101323	Ring, Lock	1
32	9-926-101324	Nut, Flexloc	2
33	9-926-101325	Washer.....	1
*34	9-926-101326	"0" Ring	2
35	9-926-101327	Ring, Reaction (.5 Sq. In.)	2
	9-926-101346	Kit, Valve Seal	

*These Items Included in Valve Seal Kit

N.S.S. - Not Sold Separately

Name Plate On Valve Specifies The Model And Ball Stud Position-And This Should Be Included When Ordering A Valve Assembly Or Housing

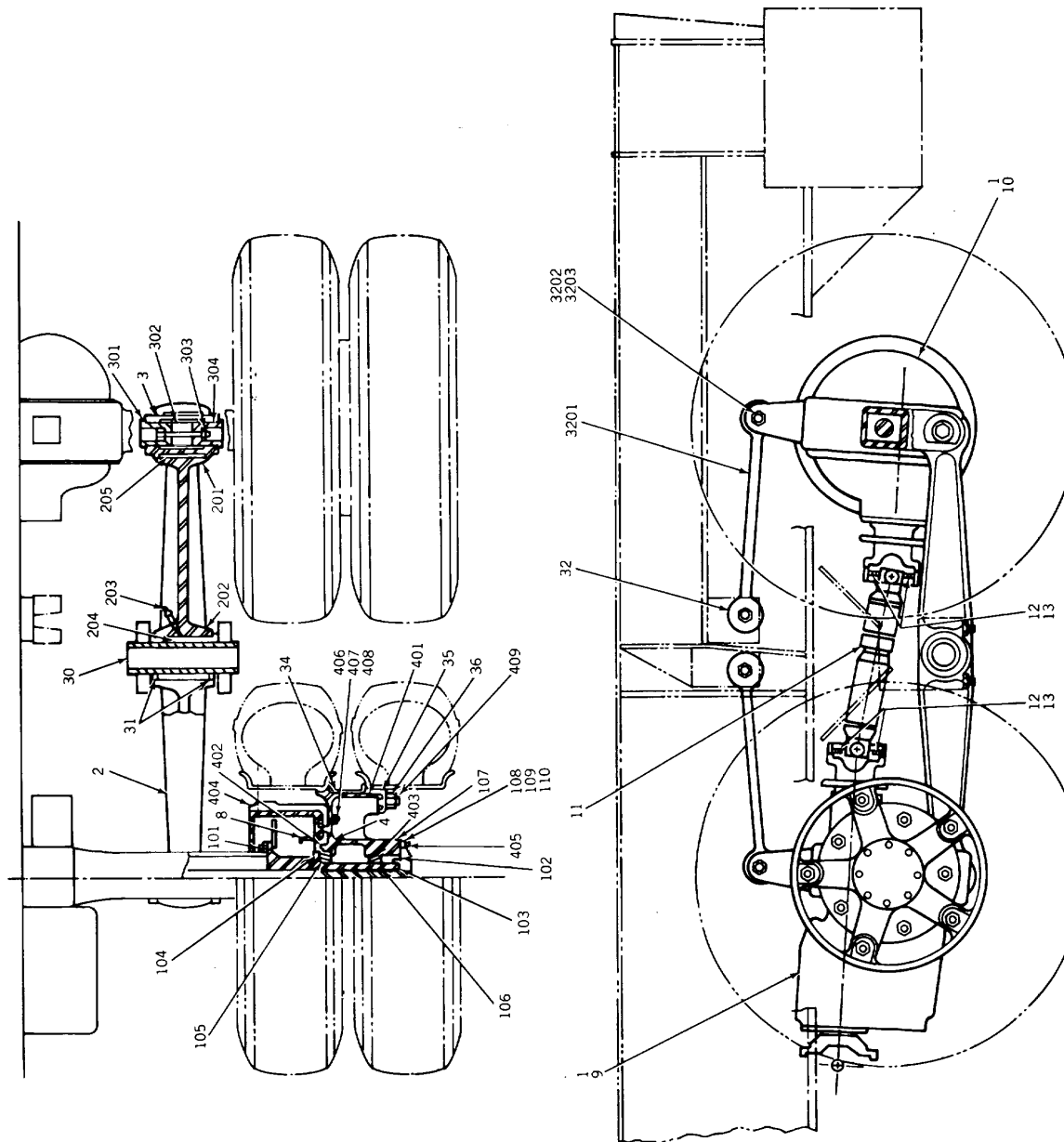

REF. NO.	PART NUMBER	DESCRIPTION	NO. REQ'D
REAR AXLE ASSEMBLY & INSTALLATION (ROCKWELL S.S.H.D.)			
1	7-576-000245	Loose Shipping Group.....	2
2	7-067-000010	Equalizing Beam Assembly.....	2
3	7-013-000267	Adapter, Beam End.....	4
4	7-970-000371	Wheel & Drum Assembly	4
8	7-970-000587	Grease Slinger	4
* 9	7-049-000214	Front Rear Axle Assembly - Rockwell S.S.H.D.	1
* 9A	7-049-000225	Front Rear Axle Assembly - Rockwell S.S.H.D.	1
* 9B	7-049-000297	Front Rear Axle Assembly - Rockwell S.S.H.D.	1
*10	7-049-000171	Rear Rear Axle Assembly - Rockwell S.S.H.D.....	1
*10A	7-049-000215	Rear Rear Axle Assembly - Rockwell S.S.H.D.....	1
*10B	7-049-000298	Rear Rear Axle Assembly - Rockwell S.S.H.D.....	1
11	7-364-000515	Inner Axle Shaft	1
12	MS35340-48	Lockwasher 1/2" Heavy - Steel.....	8
13	7-108-182050	Capscrew.....	4
30	7-822-000020	Sleeve, Beam Center	2
31	7-949-000192	Washer, Thrust	A/R
32	7-768-000310	Torque Rod Assembly.....	2
34	7-056-000061	Band, Spacer.....	4
35	7-300-000161	Clamp, Rim	20
36	7-660-221318	Nut, Heavy Hex.....	20
101	9-049-101605	Inner Oil Seal Assembly.....	2
102	9-049-101606	Outer Oil Seal Assembly.....	2
103	9-049-101607	Outer Wiper Assembly	2
104	9-049-101608	Inner Wiper Assembly	2
105	9-049-101609	Cone Inner	2
106	9-049-101610	Cone Outer	2
107	9-049-103126	Gasket.....	4
108	9-049-101547	Dowel	16
109	9-049-101548	Shake Proof Washer	16
110	9-049-101549	Nut	16
201	9-049-104096	Beam	1
202	9-049-101612	Seal	2

REF. NO.	PART NUMBER	DESCRIPTION	NO. REQ'D
REAR AXLE ASSEMBLY & INSTALLATION (ROCKWELL S.S.H.D.)			
203	9-049-102448	Alemite Fitting.....	1
204	9-270-101275	Center Bushing Assembly.....	1
205	9-270-101469	End Bushing Assembly.....	2
401	9-049-103553	Wheel Spider.....	1
402	7-794-000097	Inner Bearing Cup.....	1
403	7-794-000185	Outer Bearing Cup.....	1
404	9-049-103556	Brake Drum	1
405	9-049-101632	Drive Flange Stud	8
406	9-049-103410	Drum Bolt	5
407	9-049-103411	Flatwasher	10
408	9-049-103412	Locknut.....	5
409	9-049-101628	Rim Stud.....	5
3201	9-049-101618	Torque Rod	1
3202	9-049-101619	Locknut.....	2
3203	9-049-101620	Spacer	2

A/R - As Required

* Please Check M.C.I. For Axle Usage

Sheet 2 of 2

6-049-000219

B-43

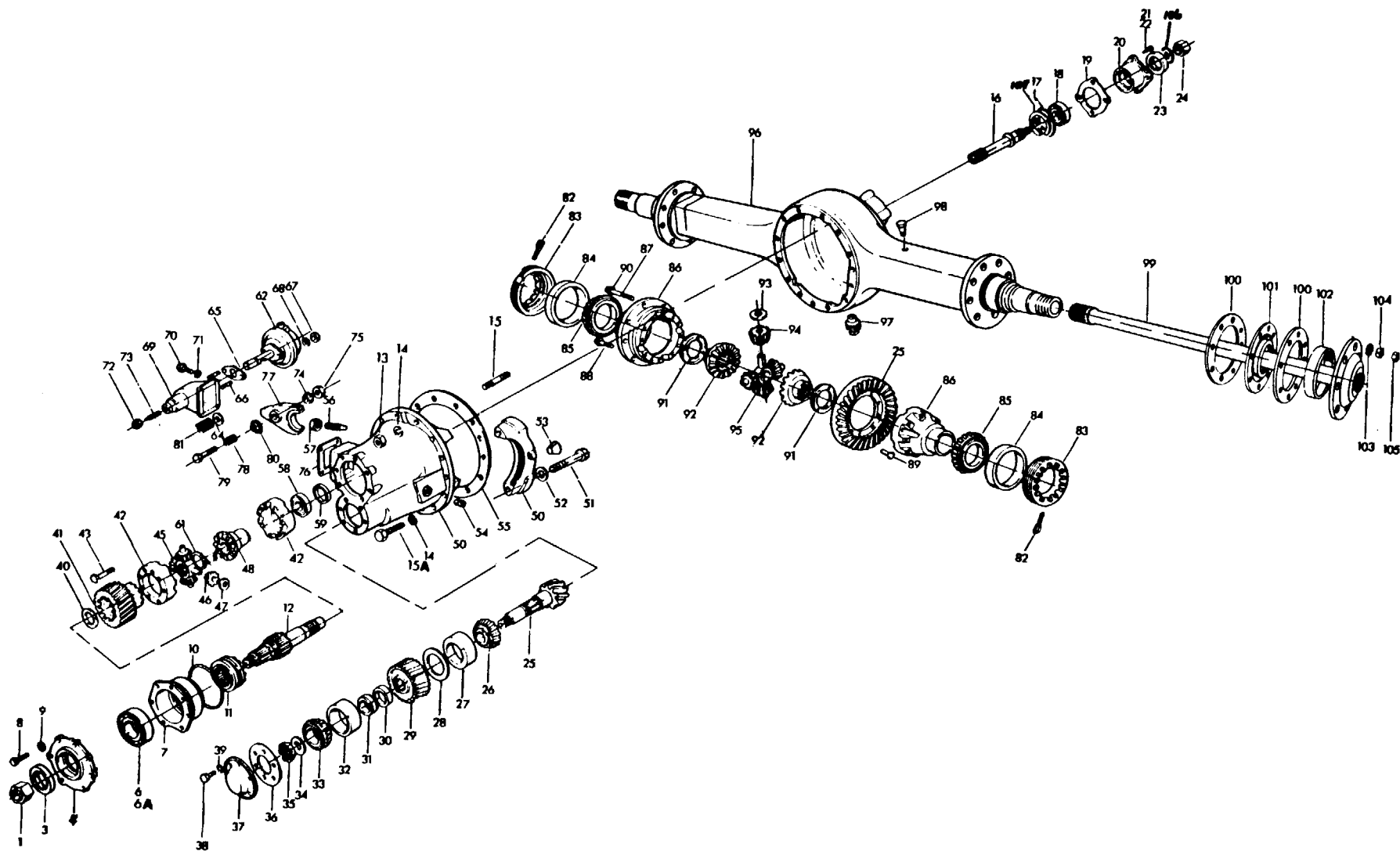

Sheet 1 of 12

7-049-000297

B-44

REF. NO.	PART NUMBER	DESCRIPTION	NO. REQ'D
	7-049-000297	Forward Rear Axle Assembly	
1	9-049-101515	Nut, Companion Flange	1
3	9-049-104376	Oil Seal Assembly.....	1
4	9-049-104005	Shim (.003).....	3
	9-049-104006	Shim (.005).....	2
	9-049-104007	Shim (.010).....	1
6	9-049-104004	Cup, Bearing	1
6A	9-049-103998	Cone, Bearing	1
7	9-049-104003	Cage Assembly	1
8	9-049-101466	Capscrew, Bearing Cage	7
9	9-049-101469	Washer, Bearing Cage.....	7
10	9-049-103154	"O" Ring, Bearing Cage	1
11	9-049-101473	Collar, Clutch	1
12	9-049-104377	Shaft, Input	1
13	9-049-102088	Nut, Carrier to Housing - Standard	5
	9-049-103965	Nut, Carrier to Housing - Heavy	1
14	9-049-101705	Lockwasher, Carrier to Housing	14
15	9-049-101558	Stud, Carrier to Housing - Short	3
	9-049-101560	Stud, Carrier to Housing - Long	2
15A	9-049-103753	Bolt, Carrier to Housing - Short	6
	9-049-103106	Bolt, Carrier to Housing - Long	2
16	9-049-104384	Shaft, Thru.....	1
17	9-049-104385	Thrust Washer	1
18	9-049-104386	Cup, Bearing	2
18A	9-049-104389	Cone, Bearing	2
19	9-049-101567	Gasket, Bearing Cage.....	1
20	9-049-104387	Bearing Cage Assembly - Includes Item 18	1
21	9-049-103754	Capscrew, Bearing Cage	4
22	9-049-103755	Washer, Bearing Cage.....	4
23	9-049-101570	Oil Seal Assembly.....	1
24	9-049-104388	Nut, Companion Flange	1
25	9-049-103766	Drive Gear & Pinion Assembly (6.14 Ratio).....	1
26	9-049-101536	Bearing, Drive Pinion Inner	1
27	9-049-101535	Cup, Drive Pinion Inner Bearing	1
28	9-049-101521	Shim (.003).....	4
	9-049-101522	Shim (.005).....	2
	9-049-101523	Shim (.010).....	4
29	9-049-101511	Gear, Drive Pinion.....	1
30	9-049-101519	Spacer, Outer Pinion Gear.....	1
31	9-049-103061	Spacer, Bearing Cone (.500)	A/R
	9-049-103062	Spacer, Bearing Cone (.501)	A/R
	9-049-103063	Spacer, Bearing Cone (.502)	A/R
	9-049-103064	Spacer, Bearing Cone (.503)	A/R
	9-049-103065	Spacer, Bearing Cone (.504)	A/R
	9-049-103066	Spacer, Bearing Cone (.505)	A/R
	9-049-103067	Spacer, Bearing Cone (.506)	A/R

REF. NO.	PART NUMBER	DESCRIPTION	NO. REQ'D
FORWARD REAR AXLE ASSEMBLY			
9-049-103068		Spacer, Bearing Cone (.507).....	A/R
9-049-103069		Spacer, Bearing Cone (.508).....	A/R
9-049-103070		Spacer, Bearing Cone (.509).....	A/R
9-049-103071		Spacer, Bearing Cone (.510).....	A/R
9-049-103072		Spacer, Bearing Cone (.511).....	A/R
9-049-103073		Spacer, Bearing Cone (.512).....	A/R
9-049-103074		Spacer, Bearing Cone (.513).....	A/R
9-049-103075		Spacer, Bearing Cone (.514).....	A/R
9-049-103076		Spacer, Bearing Cone (.515).....	A/R
9-049-103077		Spacer, Bearing Cone (.516).....	A/R
9-049-103078		Spacer, Bearing Cone (.517).....	A/R
9-049-103079		Spacer, Bearing Cone (.518).....	A/R
9-049-103080		Spacer, Bearing Cone (.519).....	A/R
9-049-103081		Spacer, Bearing Cone (.520).....	A/R
9-049-103082		Spacer, Bearing Cone (.521).....	A/R
9-049-103083		Spacer, Bearing Cone (.522).....	A/R
9-049-103084		Spacer, Bearing Cone (.523).....	A/R
9-049-103085		Spacer, Bearing Cone (.524).....	A/R
9-049-3103086		Spacer, Bearing Cone (.525).....	A/R
9-049-103087		Spacer, Bearing Cone (.526).....	A/R
9-049-103088		Spacer, Bearing Cone (.527).....	A/R
9-049-103089		Spacer, Bearing Cone (.528).....	A/R
9-049-103090		Spacer, Bearing Cone (.529).....	A/R
9-049-103091		Spacer, Bearing Cone (.530).....	A/R
9-049-103092		Spacer, Bearing Cone (.531).....	A/R
9-049-103093		Spacer, Bearing Cone (.532).....	A/R
9-049-103094		Spacer, Bearing Cone (.533).....	A/R
9-049-103095		Spacer, Bearing Cone (.534).....	A/R
9-049-103130		Spacer, Bearing Cone (.480).....	A/R
9-049-103131		Spacer, Bearing Cone (.481).....	A/R
9-049-103132		Spacer, Bearing Cone (.482).....	A/R
9-049-103133		Spacer, Bearing Cone (.483).....	A/R
9-049-103134		Spacer, Bearing Cone (.484).....	A/R
9-049-103135		Spacer, Bearing Cone (.485).....	A/R
9-049-103136		Spacer, Bearing Cone (.486).....	A/R
9-049-103137		Spacer, Bearing Cone (.487).....	A/R
9-049-103138		Spacer, Bearing Cone (.488).....	A/R
9-049-103139		Spacer, Bearing Cone (.489).....	A/R
9-049-103140		Spacer, Bearing Cone (.490).....	A/R
9-049-103141		Spacer, Bearing Cone (.491).....	A/R
9-049-103142		Spacer, Bearing Cone (.492).....	A/R
9-049-103143		Spacer, Bearing Cone (.493).....	A/R
9-049-103144		Spacer, Bearing Cone (.494).....	A/R
9-049-103145		Spacer, Bearing Cone (.495).....	A/R
9-049-103146		Spacer, Bearing Cone (.496).....	A/R
9-049-103147		Spacer, Bearing Cone (.497).....	A/R
9-049-103148		Spacer, Bearing Cone (.498).....	A/R
9-049-103149		Spacer, Bearing Cone (.499).....	A/R

REF. NO.	PART NUMBER	DESCRIPTION	NO. REQ'D
FORWARD REAR AXLE ASSEMBLY			
32	9-049-101518	Cup, Drive Pinion Outer Bearing.....	1
33	9-049-101517	Bearing, Drive Pinion Outer.....	1
34	9-049-101516	Washer, Drive Pinion.....	1
35	9-049-101515	Nut, Drive Pinion.....	1
36	9-049-101514	Gasket, Bearing Cover	1
37	9-049-101513	Cover, Drive Pinion Bearing	1
38	9-274-100104	Capscrew, Bearing Cover	6
39	9-049-101479	Washer, Bearing Cover	6
40	9-049-101512	Washer, Driven Gear Thrust	1
41	9-049-101520	Gear, Driven Input	1
42	9-049-104378	Differential Case Assembly	1
43	9-049-104379	Bolt Nut Kit	1
45	9-049-103999	Spider, Differential.....	1
46	9-049-101509	Pinion, Inter-Differential	4
47	9-049-101508	Washer, Thrust	4
48	9-049-104000	Gear, Differential Side	1
50	9-049-103995	Differential Carrier & Cap Assembly.....	1
51	9-049-101553	Capscrew, Bearing Cap	4
52	9-049-101554	Washer, Flat	4
53	9-049-101602	Pin, Dowel.....	4
54	9-049-101700	Plug, Filler	1
55		Gasket, - Use Silastic Gasket Material	
56	9-049-101498	Screw, Thrust Block	1
57	9-049-101497	Nut, Thrust Block.....	1
58	7-069-000183	Bearing Cone - Inner	1
59	7-794-000272	Bearing Cup - Outer	1
61	9-049-104380	Retainer, Snap Ring.....	2
62	9-049-104008	Air Shaft Assembly	1
64	9-049-101486	Washer, Shift Spring	1
65	9-049-101477	Gasket, Chamber to Housing	1
66	9-049-104061	Studs	2
67	9-274-100297	Nut	2
68	9-049-101475	Lockwasher	2
69	9-049-101481	Shift Fork Housing Assembly.....	1
70	9-049-103754	Capscrew.....	4
71	9-049-101479	Lockwasher	4
72	9-049-104381	Nut, Jam.....	1
73	9-049-104382	Screw, Stop	1
74	9-049-101493	Ball, Shift Fork Spring	1
75	9-049-103160	Nut.....	1
76	9-049-101500	Gasket, Shift Housing	1
77	9-049-101492	Shift Fork & Yoke Assembly.....	1
78	9-049-101488	Spring, Shift Fork.....	1
79	9-049-103156	Bolt	1
80	9-049-101491	Washer, Seat	1
81	9-049-101485	Spring, Shift	1

REF. NO.	PART NUMBER	DESCRIPTION	NO. REQ'D
FORWARD REAR AXLE ASSEMBLY			
82	9-049-103114	Cotter	2
83	9-049-103113	Nut, Adjusting Ring	2
84	9-049-103112	Cup, Bearing	2
85	9-049-103111	Cone, Bearing	2
86	9-049-103105	Differential Case Assembly - Includes Items #87, #88 & #90.....	1
87	9-049-104373	Bolt, Differential Case - Long	8
88	9-049-104374	Bolt, Differential Case - Short.....	4
89	9-049-103762	Bolt	12
89A	9-049-103001	Nut -	12
89B	9-049-101705	Washer	12
90	9-049-101705	Washer	12
91	9-049-102158	Washer, Thrust	2
92	9-049-104375	Gear, Differential Side	2
93	9-049-102160	Washer, Thrust	4
94	9-049-103109	Pinion, Differential	4
95	9-049-103108	Spider, Differential.....	1
96	9-049-104408	Axle Housing Assembly.....	1
97	9-049-101700	Drain, Magnetic	1
98	9-049-101572	Axle Housing Breather Assembly	1
99	9-049-104390	Shaft, Axle - L.H.	1
	9-049-104391	Shaft, Axle - R.H.....	1
100	9-049-103126	Gasket (2 Per Wheel)	4
101	9-049-101605	Seal, Oil (1 Per Wheel).....	2
102	9-049-101608	Wiper (1 Per Wheel).....	2
103	9-049-101548	Lockwasher (8 Per Wheel)	16
104	9-049-101547	Dowel (8 Per Wheel)	16
105	9-049-102088	Nut (8 Per Wheel).....	16
106	9-049-104393	Washer.....	1
107	9-049-104394	Spacer, Snap Ring (.155).....	1 A/R
107A	9-049-104395	Spacer, Snap Ring (.158)	1 A/R
107B	9-049-104396	Spacer, Snap Ring (.161).....	1 A/R
107C	9-049-104397	Spacer, Snap Ring (.164).....	1 A/R
107D	9-049-104398	Spacer, Snap Ring (.167).....	1 A/R
107E	9-049-104399	Spacer, Snap Ring (.170).....	1 A/R
107F	9-049-104400	Spacer, Snap Ring (.173)	1 A/R
107G	9-049-104401	Spacer, Snap Ring (.176)	1 A/R
107H	9-049-104402	Spacer, Snap Ring (.179)	1 A/R
107I	9-049-104403	Spacer, Snap Ring (.182)	1 A/R

ITEMS NOT ILLUSTRATED

9-049-103760	Bracket, Beam Hanger - L.H	1
9-049-103761	Bracket, Beam Hanger - R.H.....	1
9-049-101701	Bracket, Torque Rod - Upper.....	1
9-049-103159	Heat Indicator Plug Assembly	2

REF. NO.	PART NUMBER	DESCRIPTION	NO. REQ'D
FORWARD REAR AXLE ASSEMBLY			
9-049-103762		Bolt, Brake Attaching - Long (2 Per Wheel)	2
9-049-104014		Bolt, Brake Attaching - Short (6 Per Wheel).....	12
9-049-102036		Washer, Brake Attaching (16 Per Wheel)	32
9-049-103001		Nut, Brake Attaching (8 Per Wheel)	16
9-049-101703		Nut, OUtter Wheel Bearing.....	2
9-049-101702		Nut, Inner Wheel Bearing.....	2
9-049-101704		Washer, Wheel Bearing.....	2
9-049-104360		Complete Differential Carrier Assembly.....	1
9-049-104392		Yoke, Companion Rear	1
9-049-104383		Companion Yoke Assembly - Front Output	1
9-049-104009		Washer, Special	1
9-049-101606		Oil Seal - Outer Wheel	2
9-049-101607		Wiper, Oil Seal - Outer.....	2
9-049-101609		Cone, Inner Wheel	2
9-734-100120		Cone, Outer Wheel	2

A/R - As Required

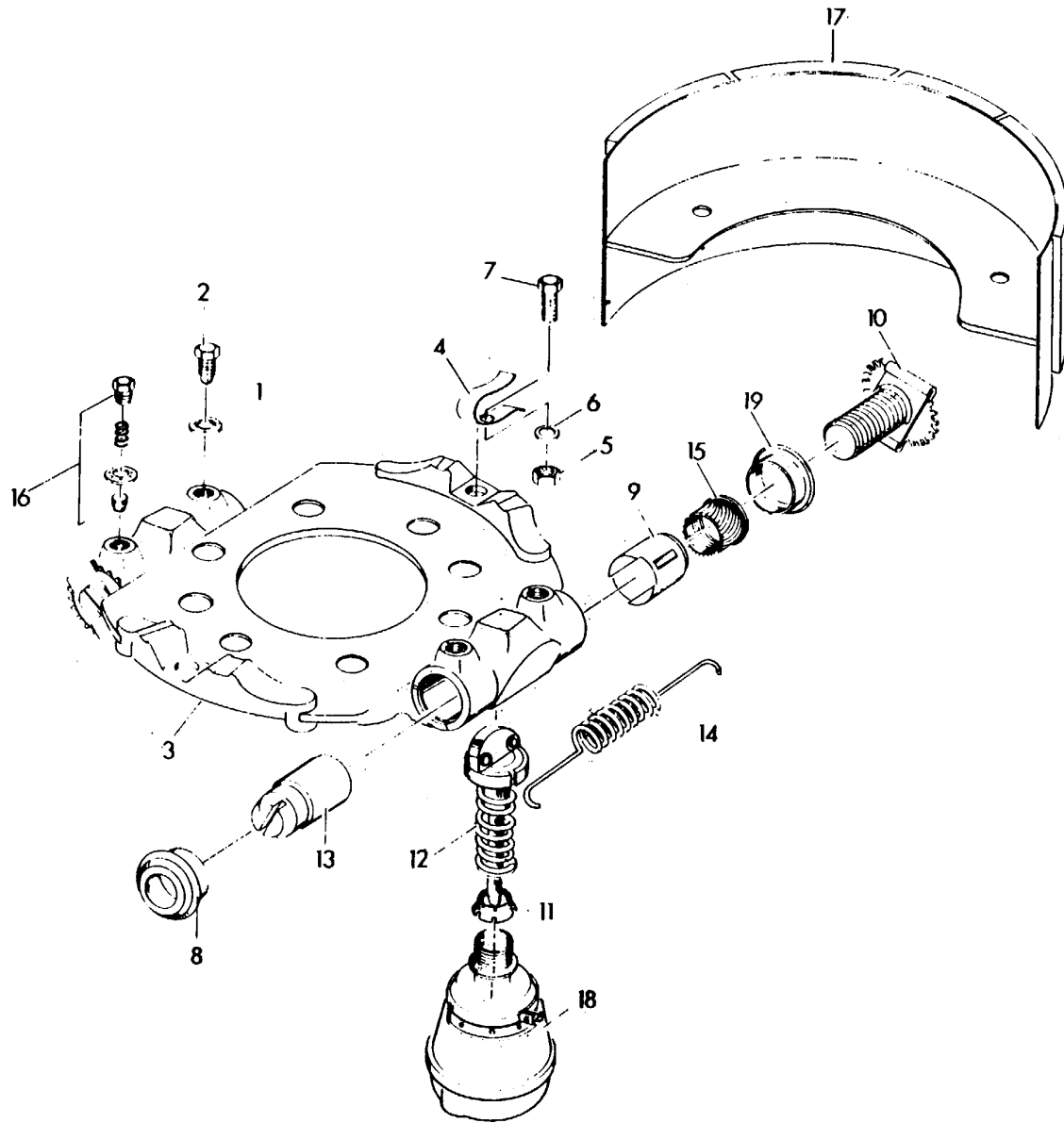

Sheet 7 of 12

REF. NO.	PART NUMBER	DESCRIPTION	NO. REQ'D
COMPLETE BRAKE ASSEMBLY - (15" x 7")			
	9-049-103772	Brake Assembly (L.H.)	
	9-049-103773	Brake Assembly (R.H.)	
1	9-049-101717	Gasket.....	4
2	9-049-101720	Guide, Plunger	2
3	9-049-103774	Spider, Brake.....	1
4	9-049-101709	Clip, Hold Down	2
5	9-049-102550	Nut, Hold Down	2
6	9-049-101712	Lockwasher, Hold	2
7	9-049-101710	Capscrew, Hold Down	2
8	9-049-101713	Retainer Assembly.....	2
9	9-049-103174	Plunger, Adjusting	2
10	9-049-103175	Adjusting Bolt Assembly	2
11	9-049-101760	Nut, Spanner	2
12	9-049-101724	Wedge Assembly	2
		(For individual parts breakdown see page #9 & #10)	
13	9-049-101722	Plunger, Anchor (L.H.).....	2
	9-049-101723	Plunger, Anchor (R.H.).....	2
14	9-049-101643	Spring, Shoe Return	2
15	9-049-103176	Actuator, Adjusting.....	2
16	9-049-103177	Adjusting Pawl Assembly	2
17	9-049-103775	Shoe & Lining.....	2
18	9-049-103776	Failsafe Chamber	1
	9-049-103777	Failsafe Chamber	1
		(For individual parts breakdown see page #11 & #12)	
19	9-049-103173	Seal	2
<u>ITEMS NOT ILLUSTRATED</u>			
	9-049-101763	Plug, Dust Cover	4
	9-049-101761	Shield, Dust	1
	9-722-100511	Capscrew, Dust Shield	4
	9-049-101762	Lockwasher, Dust Shield	4
	9-049-103778	Lining & Rivet Kit.....	1

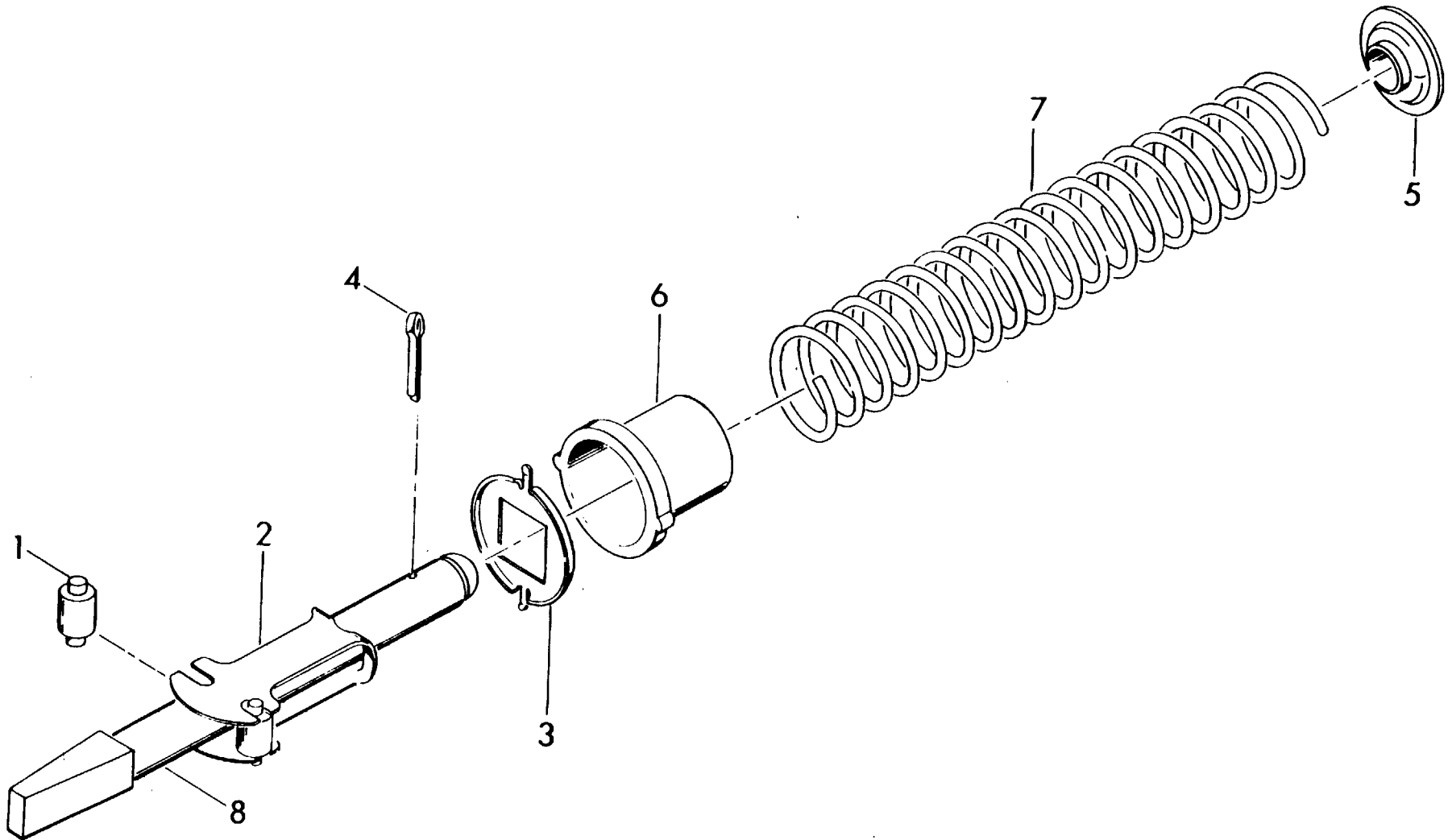

7-049-000297

Sheet 9 of 12

B-52

REF. NO.	PART NUMBER	DESCRIPTION	NO. REQ'D
		WEDGE ASSEMBLY	
	9-049-101724	Wedge Assembly	
1	9-049-101725	Roller, Wedge.....	4
2	9-049-101726	Cage, Roller.....	2
3	9-049-101728	Washer, Retaining	2
4	9-049-102551	Pin, Cotter.....	2
5	9-049-101730	Washer, Return Spring.....	2
6	9-049-101729	Boot.....	2
7	9-049-101727	Spring, Return.....	2
8	9-049-102560	Wedge	2

Sheet 10 of 12

7-049-000297

B-53

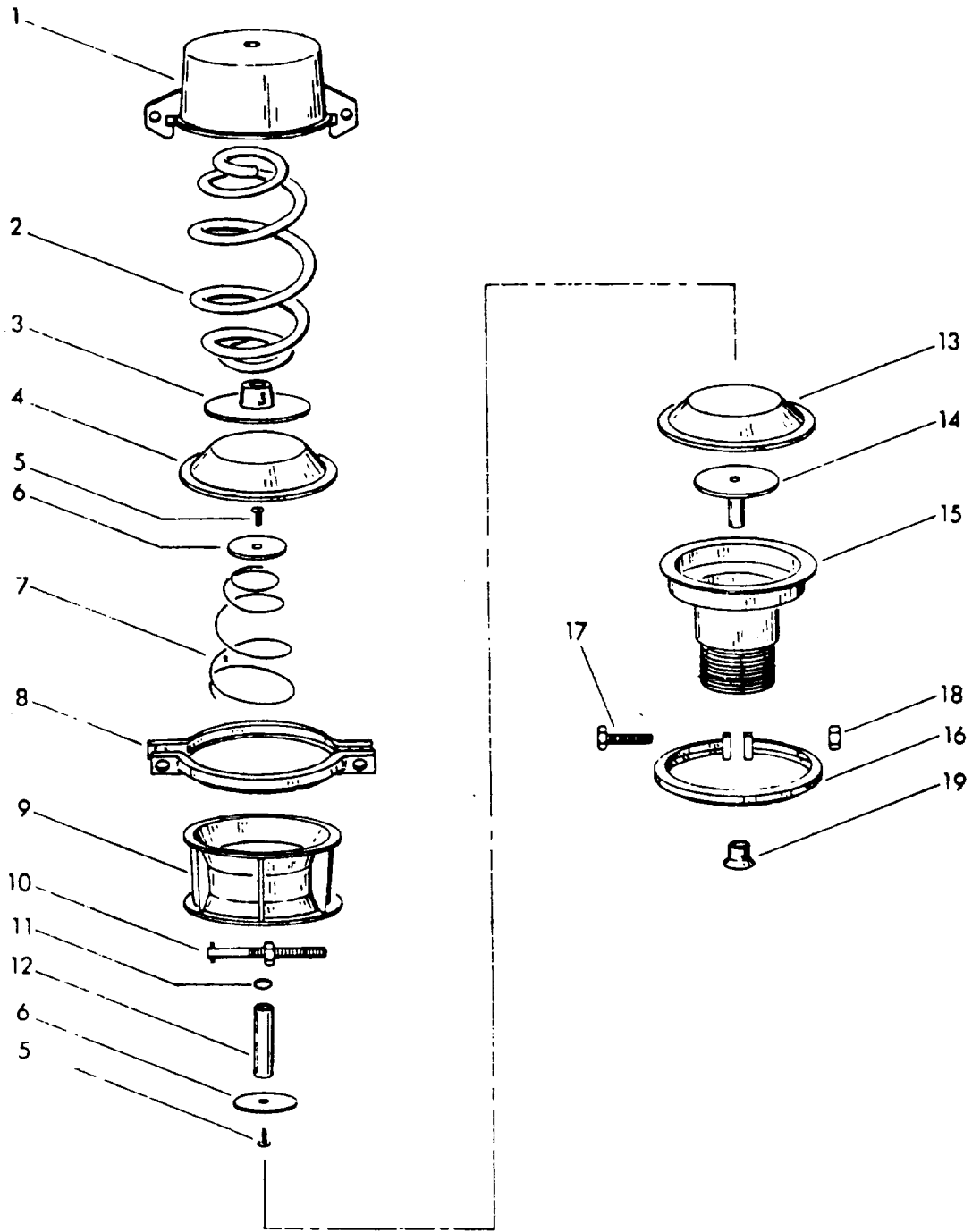

Sheet 11 of 12

7-049-000297

B-54

REF. NO.	PART NUMBER	DESCRIPTION	NO. REQ'D
FAILSAFE CHAMBER ASSEMBLY			
	9-049-104175	Failsafe Chamber Assembly	
	9-049-104174	Failsafe Chamber Assembly	
1	9-348-100149	Chamber	1
2	9-348-100150	Spring, Compression	1
3	9-348-100151	Plate, Pressure	1
4	9-348-100152	Diaphragm	1
5	9-348-100133	Screw, Nylok.....	2
6	9-348-100126	Plate.....	2
7	9-348-100130	Spring, Return.....	1
8	9-348-100153	Clamp Assembly.....	1
9	9-348-100154	Adapter	1
10	9-348-100148	Release Stud Assembly.....	1
11	7-755-114000	O-Ring	1
12	9-348-100155	Rod, Adapter Push	1
13	9-049-101754	Diaphragm	1
14	9-049-101755	Plate Assembly.....	1
15	9-049-101756	Housing, Non-Pressure	1
16	9-049-101757	Ring, Clamp	1
17	9-049-101758	Bolt.....	1
18	9-049-103189	Nut	1
19	9-049-101731	Guide	1

7-049-000297

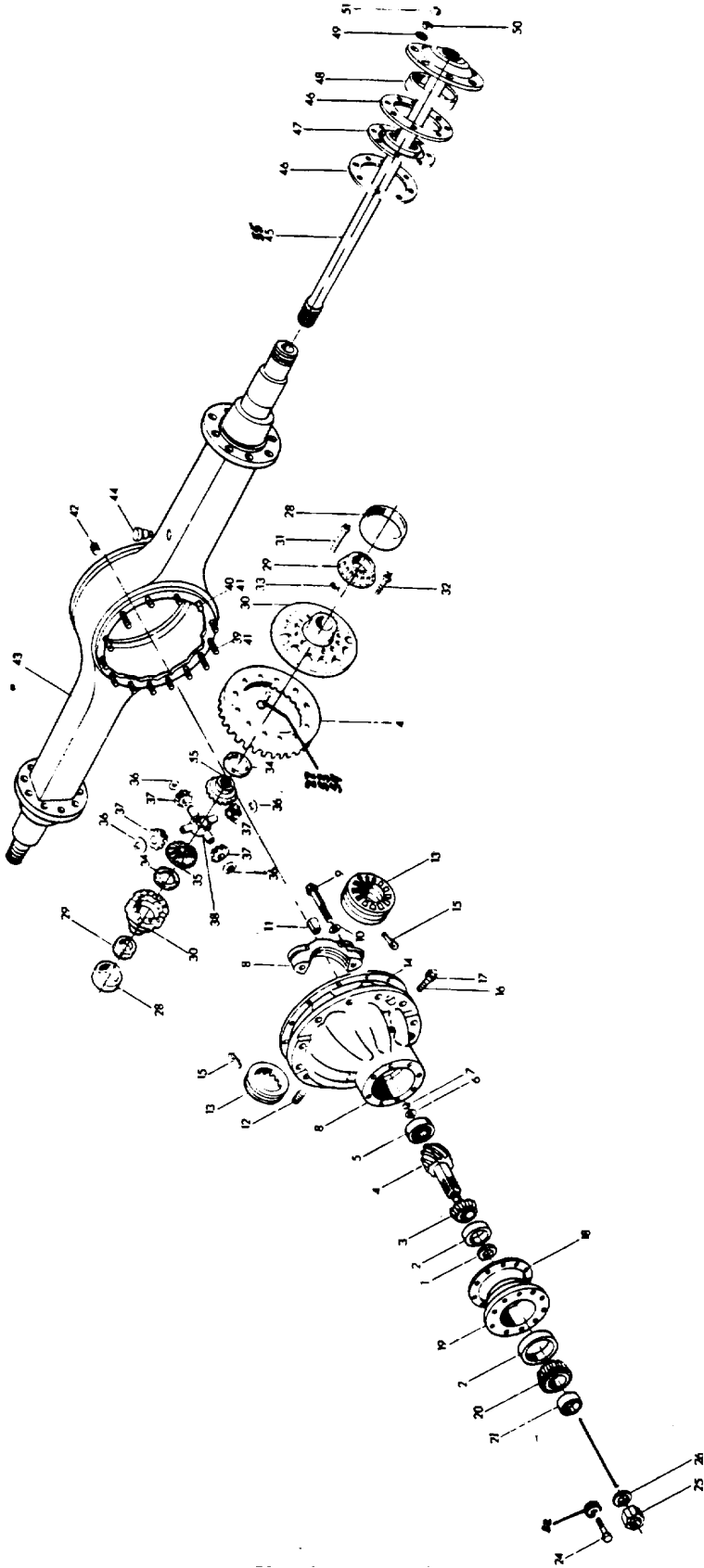

7-049-000298

REF. NO.	PART NUMBER	DESCRIPTION	NO. REQ'D
REAR AXLE ASSEMBLY			
	7-049-000298	Rear Axle Assembly	
1	9-049-103061	Spacer, Bearing Cone (.500).....	A/R
	9-049-103062	Spacer, Bearing Cone (.501).....	A/R
	9-049-103063	Spacer, Bearing Cone (.502).....	A/R
	9-049-103064	Spacer, Bearing Cone (.503).....	A/R
	9-049-103065	Spacer, Bearing Cone (.504).....	A/R
	9-049-103066	Spacer, Bearing Cone (.505).....	A/R
	9-049-103067	Spacer, Bearing Cone (.506).....	A/R
	9-049-103068	Spacer, Bearing Cone (.507).....	A/R
	9-049-103069	Spacer, Bearing Cone (.508).....	A/R
	9-049-103070	Spacer, Bearing Cone (.509).....	A/R
	9-049-103071	Spacer, Bearing Cone (.510).....	A/R
	9-049-103072	Spacer, Bearing Cone (.511).....	A/R
	9-049-103073	Spacer, Bearing Cone (.512).....	A/R
	9-049-103074	Spacer, Bearing Cone (.513).....	A/R
	9-049-103075	Spacer, Bearing Cone (.514).....	A/R
	9-049-103076	Spacer, Bearing Cone (.515).....	A/R
	9-049-103077	Spacer, Bearing Cone (.516).....	A/R
	9-049-103078	Spacer, Bearing Cone (.517).....	A/R
	9-049-103079	Spacer, Bearing Cone (.518).....	A/R
	9-049-103080	spacer, Bearing Cone (.519).....	A/R
	9-049-103081	Spacer, Bearing Cone (.520).....	A/R
	9-049-103082	Spacer, Bearing Cone (.521).....	A/R
	9-049-103083	Spacer, Bearing Cone (.522).....	A/R
	9-049-103084	Spacer, Bearing Cone (.523).....	A/R
	9-049-103085	Spacer, Bearing Cone (.524).....	A/R
	9-049-103086	Spacer, Bearing Cone (.525).....	A/R
	9-049-103087	Spacer, Bearing Cone (.526).....	A/R
	9-049-103088	Spacer, Bearing Cone (.527).....	A/R
	9-049-103089	Spacer, Bearing Cone (.528).....	A/R
	9-049-103090	Spacer, Bearing Cone (.529).....	A/R
	9-049-103091	Spacer, Bearing Cone (.530).....	A/R
	9-049-103092	Spacer, Bearing Cone (.531).....	A/R
	9-049-103093	Spacer, Bearing Cone (.532).....	A/R
	9-049-103094	Spacer, Bearing Cone (.533).....	A/R
	9-049-103095	Spacer, Bearing Cone (.534).....	A/R
2	9-049-101535	Cup, Drive Pinion Bearing	2
3	9-049-103170	Bearing, Drive Pinion Outer	1
4	9-049-104404	Drive Gear & Pinion Assembly	1
5	9-049-103057	Bearing, Pilot	1
6	9-049-103058	Retainer, Snap Ring	1
7	9-049-103059	Ring, Snap	1
8	9-049-103054	Differential Carrier & Cap Assembly	i
9	9-049-101553	Capscrew.....	4
10	9-049-101554	Washer	4
11	9-049-101602	Dowel.....	2

REF. NO.	PART NUMBER	DESCRIPTION	NO. REQ'D
REAR AXLE ASSEMBLY			
.12	9-049-101700	Plug, Filler	1
13	9-049-103113	Nut, Adjusting Ring	2
14		Gasket (Use Silastic Gasket Material)	
15	9-049-103114	Pin, Cotter	2
16	9-049-101498	Screw, Adjusting	1
17	9-049-101497	Nut, Adjusting Screw	1
18	9-049-103102	Shim (.003)	1
	9-049-103103	Shim (.005)	1
	9-049-103104	Shim (.010)	3
19	9-049-104405	Bearing Cage & Cup Assembly	1
20	9-049-101536	Bearing, Drive Pinion Inner	1
21	9-049-104406	Oil Seal Assembly.....	1
24	9-722-100512	Capscrew.....	8
25	9-049-104388	Nut, Flange	1
26	9-049-104393	Washer, Flange Nut.....	1
27	9-049-103762	Bolt.....	12
28	9-049-103112	Cup, Bearing.....	2
29	9-049-103111	Cone, Bearing.....	2
30	9-049-103105	Differential Case Assembly.....	1
	*	(Includes Items 131, #32 & #33)	
31	9-049-104373	Capscrew (Long)	8
32	9-049-104374	Capscrew (Short).....	4
33	9-049-101705	Washer	12
34	9-049-102158	Washer, Thrust	2
35	9-049-104375	Gear, Differential Side	2
36	9-049-102160	Washer, Thrust	4
37	9-049-103109	Gear, Pinion Spider	4
38	9-049-103108	Spider, Differential	1
39	9-049-103768	Capscrew (Long)	4
40	9-049-103753	Capscrew (Short).....	10
41	9-049-101705	Washer	14
42	9-049-101700	Plug, Magnetic.....	1
43	9-049-103769	Axle Housing Assembly	1
44	9-049-101572	Axle Housing Breather Assembly	1
45	9-049-104390	Shaft, Axle (R.H.).....	1
46	9-049-103126	Gasket (2 Per Wheel)	4
47	9-049-101605	Seal, Oil-Inner (1 Per Wheel)	2
48	9-049-101608	Wiper (1 Per Wheel)	2
49	9-049-101548	Lockwasher.....	16
50	9-049-101547	Dowel.....	16
51	9-049-101549	Nut	16
52	9-049-101980	Washer, Flat	8
53	9-049-101705	Washer	12
54	9-049-103001	Nut	12
55	9-049-104391	Shaft, Axle (L.H.)	1

7-049-000298

REF. NO.	PART NUMBER	DESCRIPTION	NO. REQ'D
REAR AXLE ASSEMBLY			
<u>ITEMS NOT ILLUSTRATED</u>			
	9-049-103760	Bracket, Beam Hanger (L.H.)	1
	9-049-103761	Bracket, Beam Hanger (R.H.).....	1
	9-049-101701	Bracket, Torque Rod (Upper)	1
	9-049-103159	Heat Indicator Plug Assembly.....	1
	9-049-103762	Bolt, Brake Attaching (2 Per Wheel)	4
	9-094-102036	Washer, Brake Attaching (16 Per Wheel)	32
	9-049-103001	Nut, Brake Attachine (8 Per Wheel)	16
	9-049-101703	Nut, Outer Wheel Bearing	2
	9-049-101702	Nut, Inner Wheel Bearing	2
	9-049-101704	Washer, Wheel Bearing	2
	9-049-104407	Complete Differential Carrier Assembly	1
	9-049-104392	Companion Yoke Assembly.....	1
	9-049-101606	Oil Seal (Outer Wheel)	2
	9-049-101609	Cone, Inner Wheel.....	2
	9-734-100120	Cone, Outer Wheel.....	2
	9-049-103765	Case & Nest Assembly	1
		(Includes #30, #32, #33, #34, #35, #36, #37 & #38)	
	9-049-104014	Bolt, Brake Attaching (6 Per Wheel)	12
	9-049-102416	Deflector, Slinger	1
	9-049-101607	Wiper (Outer Oil Seal)	1
			7-049-000298

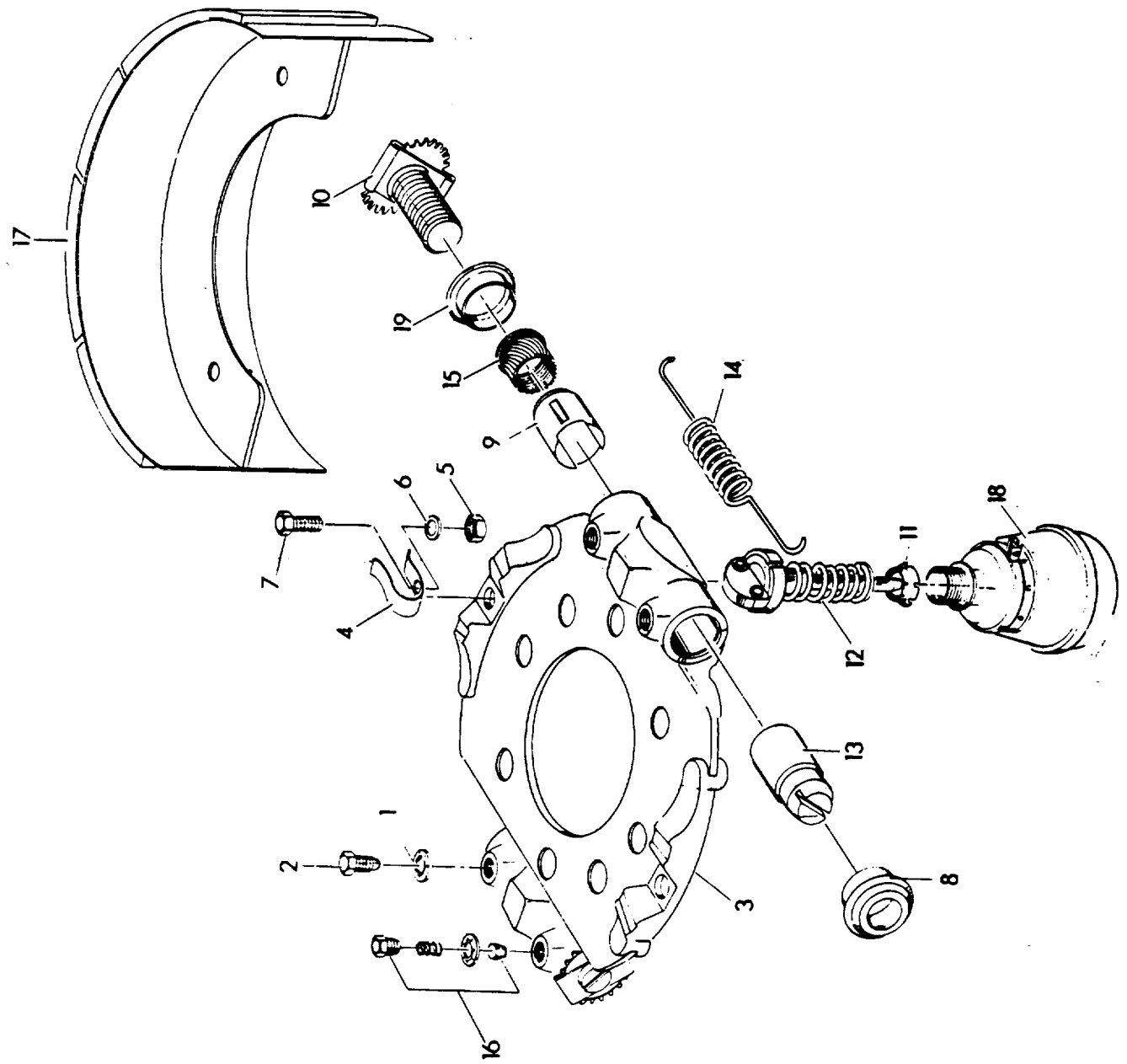

7-049-000298

REF. NO.	PART NUMBER	DESCRIPTION	NO. REQ'D
COMPLETE BRAKE ASSEMBLY - (15" x 7")			
	9-049-103772	Brake Assembly (L.H.)	
	9-049-103773	Brake Assembly (R.H.)	
1	9-049-101717	Gasket	4
2	9-049-101720	Guide, Plunger.....	2
3	9-049-103774	Spider, Brake	1
4	9-049-101709	Clip, Hold Down	2
5	9-049-102550	Nut, Hold Down.....	2
6	9-049-101712	Lockwasher, Hold Down.....	2
7	9-049-101710	Capscrew, Hold Down - -	2
8	9-049-101713	Retainer Assembly.....	2
9	9-049-103174	Plunger, Adjusting.....	2
10	9-049-103175	Adjusting Bolt Assembly	2
11	9-049-101760	Nut, Spanner.....	2
12	9-049-101724	Wedge Assembly.....	2
		(For individual parts breakdown see page #J7 & #8)	
13	9-049-101722	Plunger, Anchor (L.H.).....	2
	9-049-101723	Plunger, Anchor (R.H.)	2
14	9-049-101643	Spring, Shoe Return	2
15	9-049-103176	Actuator, Adjusting.....	2
16	9-049-103177	Adjusting Pawl Assembly.....	2
17	9-049-103775	Shoe & Lining	2
18	9-049-103776	Failsafe Chamber	1
	9-049-103777	Failsafe Chamber	1
		(For individual parts breakdown see page #9 & #10)	
19	9-049-103173	Seal.....	2
		ITEMS NOT ILLUSTRATED	
	9-049-101763	Plug, Dust Cover.....	4
	9-049-101761	Shield, Dust	1
	9-722-100511	Capscrew, Dust Shield	4
	9-049-101762	Lockwasher, Dust Shield	4
	9-049-103778	Lining & Rivet Kit.....	1

7-049-000298

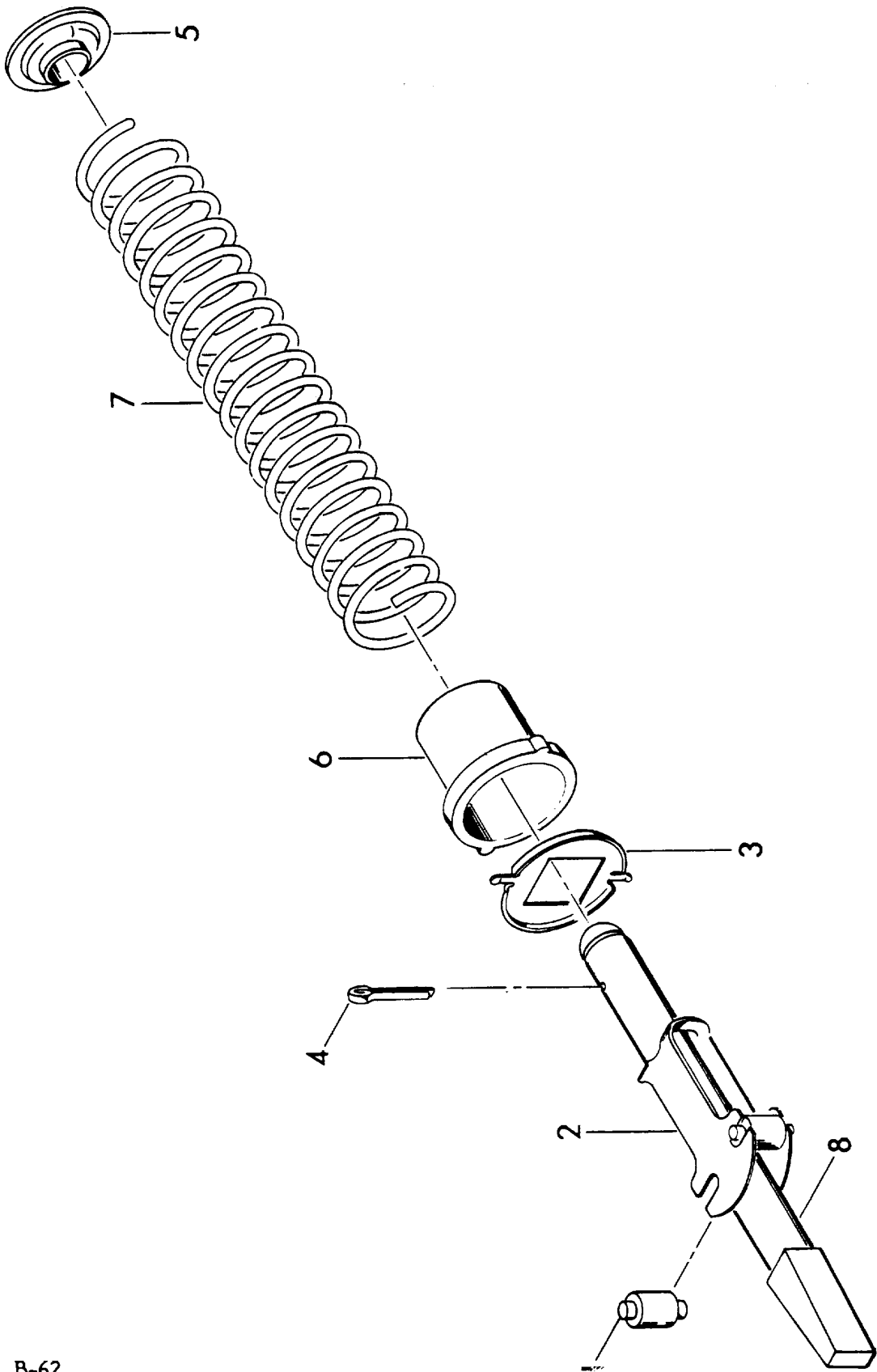

B-62
7-049-000298

REF. NO.	PART NUMBER	DESCRIPTION	NO. REQ'D
-------------	-------------	-------------	--------------

WEDGE ASSEMBLY

	9-049-101724	Wedge Assembly	
1	9-049-101725	Roller, Wedge	4
2	9-049-101726	Cage, Roller	2
3	9-049-101728	Washer, Retaining	2
4	9-049-102551	Pin, Cotter	2
5	9-049-101730	Washer, Return Spring	2
6	9-049-101729	Boot	2
7	9-049-101727	Spring, Return.....	2
8	9-049-102560	Wedge	2

7-049-000298

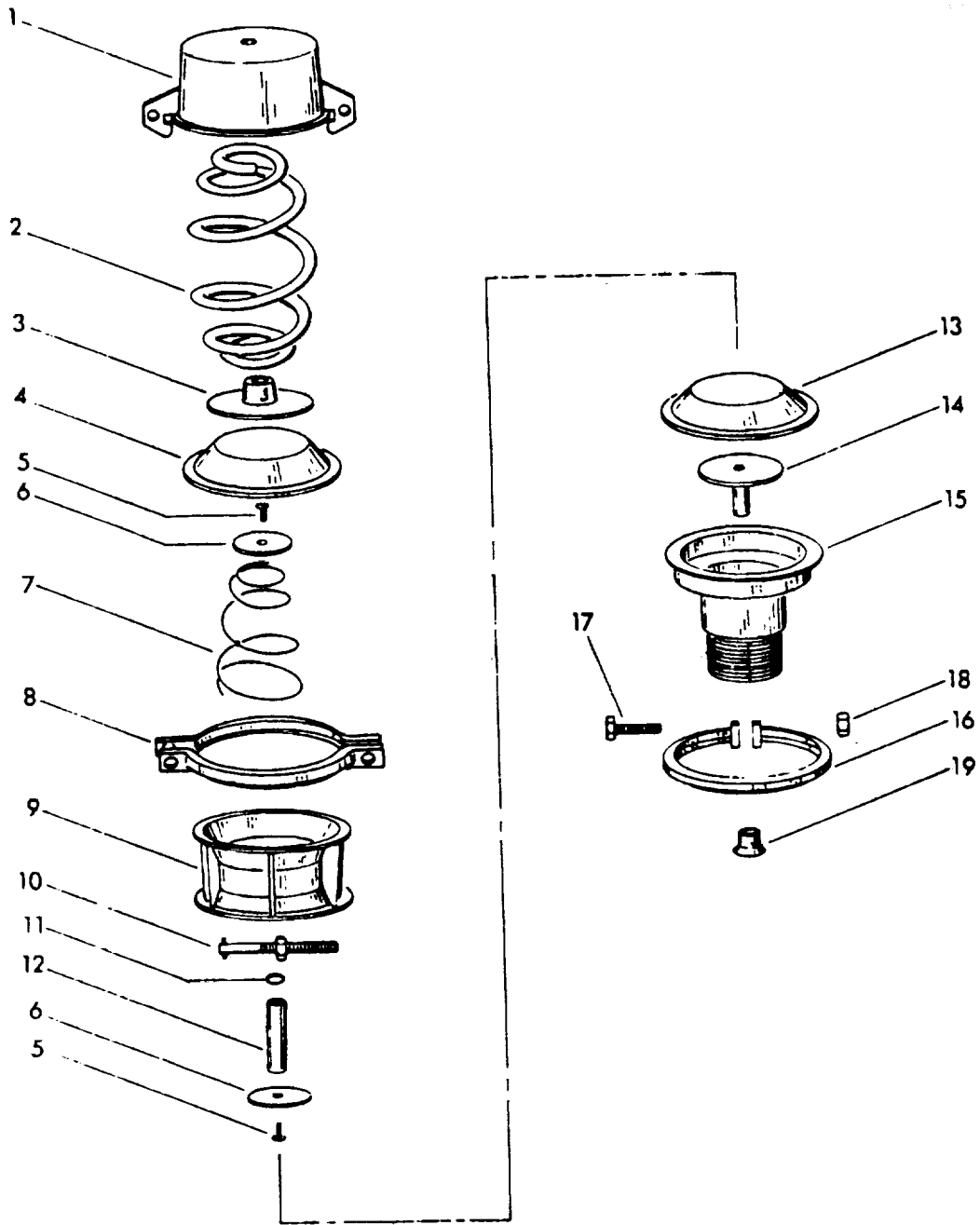

7-049-000298

REF. NO.	PART NUMBER	DESCRIPTION	NO. REQ'D
FAILSAFE CHAMBER ASSEMBLY			
	9-049-104175	Failsafe Chamber Assembly	
	9-049-104174	Failsafe Chamber Assembly'	
1	9-348-100149	Chamber	1
2	9-348-100150	Spring, Compression	1
3	9-348-100151	Plate, Pressure	1
4	9-348-100152	Diaphragm	1
5	9-348-100133	Screw, Nylok.....	2
6	9-348-100126	Plate.....	2
7	9-348-100130	Spring, Return.....	1
8	9-348-100153	Clamp Assembly.....	1
9	9-348-100154	Adapter	1
10	9-348-100148	Release Stud Assembly.....	1
11	7-755-114000	O-Ring	1
12	9-348-100155	Rod, Adapter Push	1
13	9-049-101754	Diaphragm	1
14	9-049-101755	Plate Assembly.....	1
15	9-049-101756	Housing, Non-Pressure	1
16	9-049-101757	Ring, Clamp	1
17	9-049-101758	Bolt.....	1
18	9-049-103189	Nut	1
19	9-049-101731	Guide	1

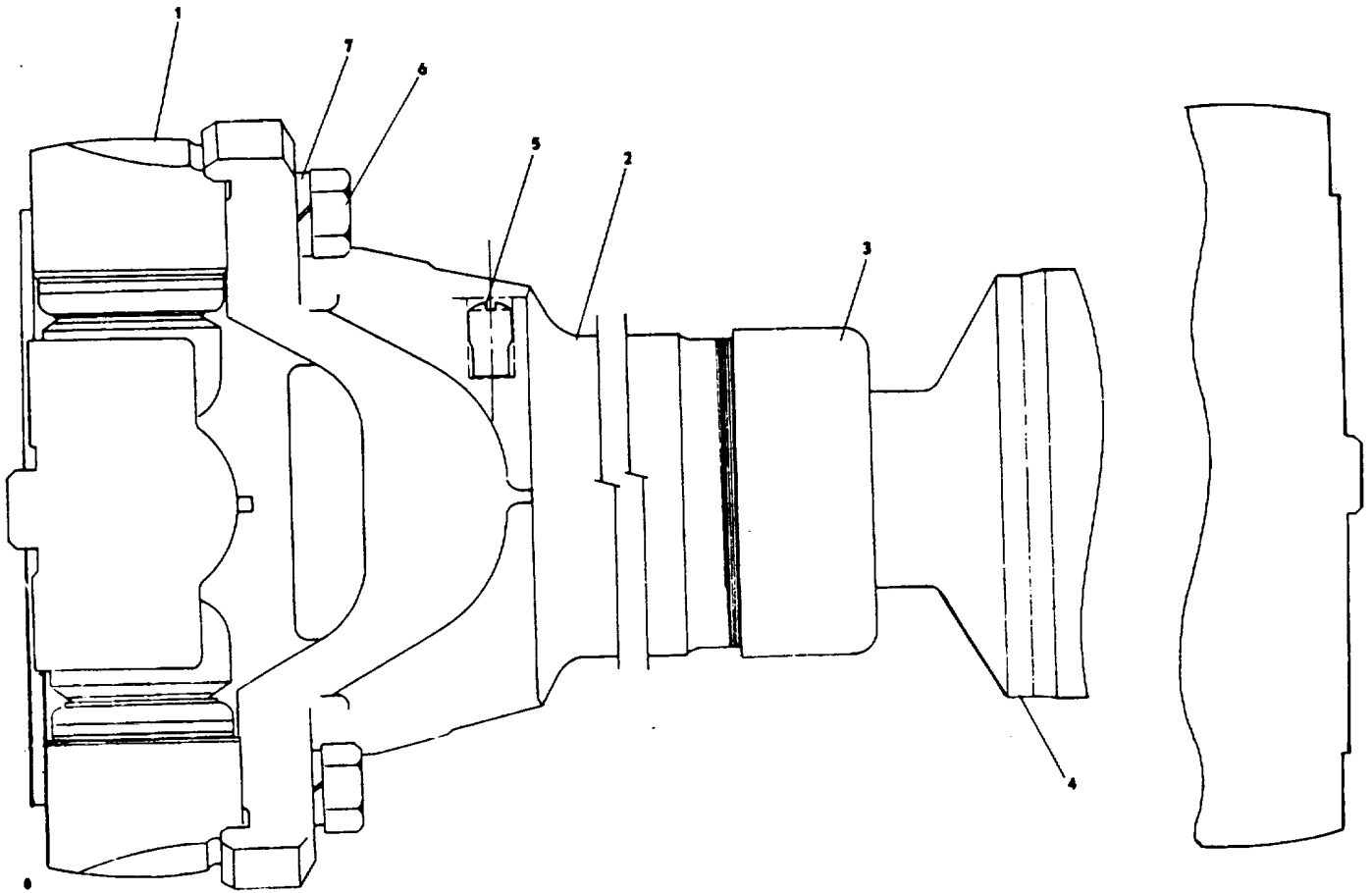

REF. NO.	PART NUMBER	DESCRIPTION	NO. REQ'D
INNER AXLE SHAFT			
1	9-364-100188	Group (U Joint)	2
2	9-364-100189	Plug.....	1
3	9-364-100190	Group.....	1
4	9-364-100191	Plug, Spline.....	1
5	9-364-100192	Plug, Oil	1
6	9-364-100193	Screw, Cap	8
7	9-364-100194	Washer, Lock	8

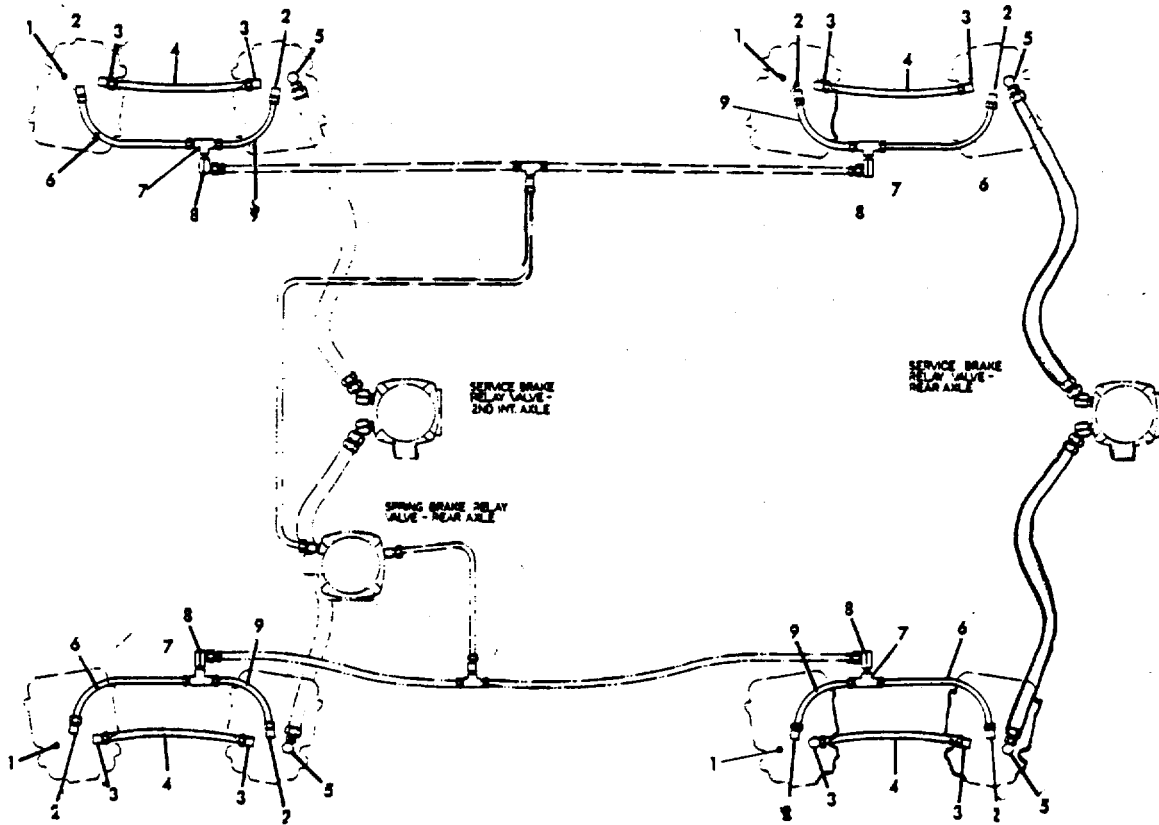

REF. NO.	PART NUMBER	DESCRIPTION	NO. REQ'D
REAR AXLE AIR SCHEMATIC			
1	7-444-030031	Plug, Hex Countersunk Head Pipe 3/8" N.P.T.	
		Cast Iron	4
2	7-446-060607	Elbow, Male	8
3	7-446-080607	Elbow, Male	8
4	6-911-081120	Tubing	4
5	7-445-060809	Adapter, Swivel.....	4
6	6-911-060960	Tubing -.....	4
7	7-446-060414	Tee, Branch	4
8	7-445-040604	Adapter, Swivel.....	4
9	6-911-061120	Tubing.....	4

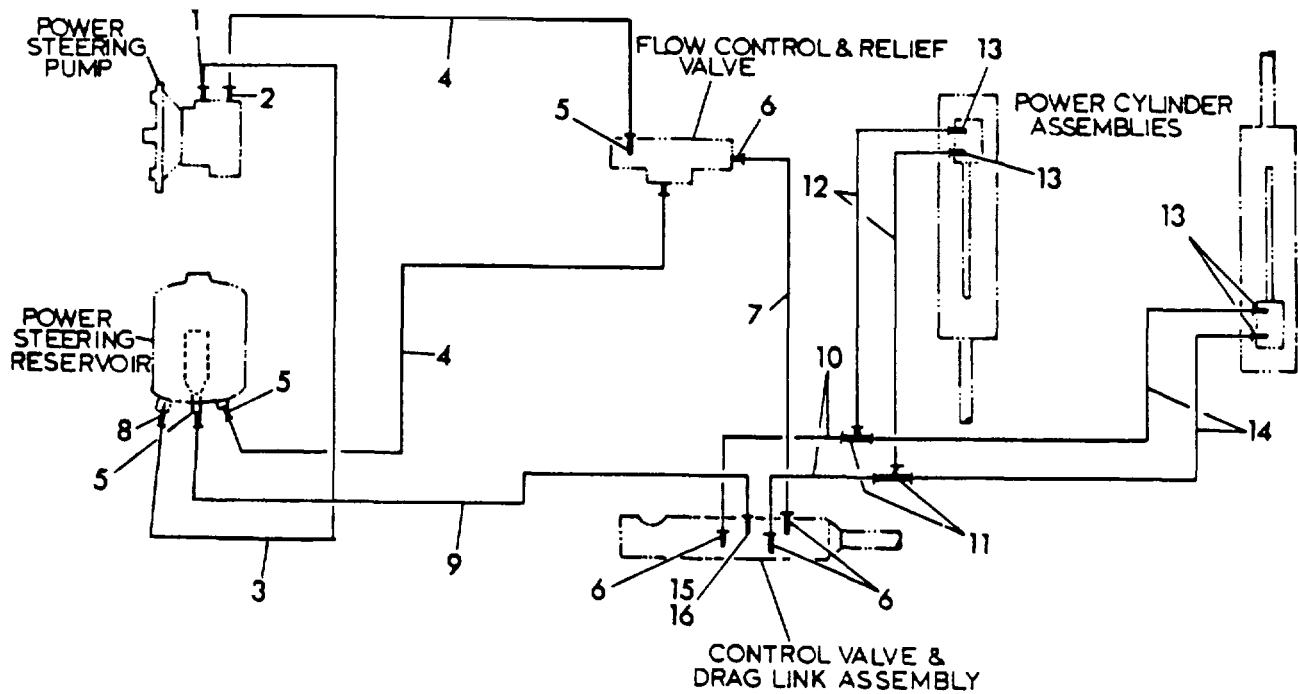

REF. NO.	PART NUMBER	DESCRIPTION	NO. REQ'D
----------	-------------	-------------	-----------

POWER STEERING SCHEMATIC - G.M.C. ENGINE

1	7-445-161601	Adapter, Swivel.....	1
2	7-445-080804	Adapter, Swivel.....	1
3	7-542-501809	Hose	1
4	7-542-301806	Hose	2
5	7-445-080809	Adapter, Swivel.....	3
6	7-445-060604	Adapter, Swivel.....	4
7	7-542-211611	Hose	1
8	7-445-161604	Adapter, Swivel.....	1
9	7-542-312606	Hose	1
10	7-542-208811	Hose	2
11	7-445-060614	Adapter, Swivel.....	2
12	7-542-203411	Hose	2
13	7-445-060609	Adapter, Swivel.....	4
14	7-542-205811	Hose	2
15	7-445-080804	Adapter, Swivel.....	1
16	7-445-060817	Connector, Reducing.....	1

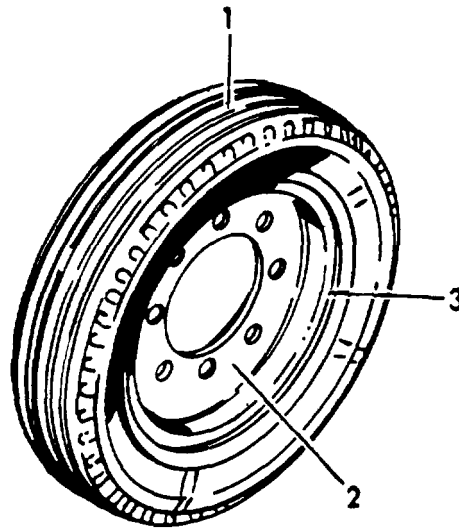

REF. NO.	PART NUMBER	DESCRIPTION	NO. REQ'D
TIRE & WHEEL ASSEMBLY - 11:00 x 20			
	6-970-000237	Tire & Wheel Assembly - General	
1	7-900-000112	Tire - 12 Ply	1
2	7-061-000034	Base, Rim	1
3	7-753-000337	Ring, Side	1
			6-970-000237

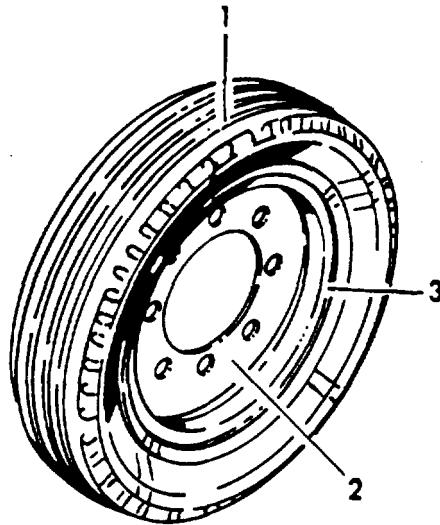

REF. NO.	PART NUMBER	DESCRIPTION	NO. REQ'D
TIRE & WHEEL ASSEMBLY - 11:00 x 20			
	6-970-000232	Tire & Wheel Assembly - General	
1	7-900-000097	Tire - 12 Ply	1
2	7-061-000034	Base, Rim	1
3	7-753-000337	Ring, Side	1
			6-970-000232

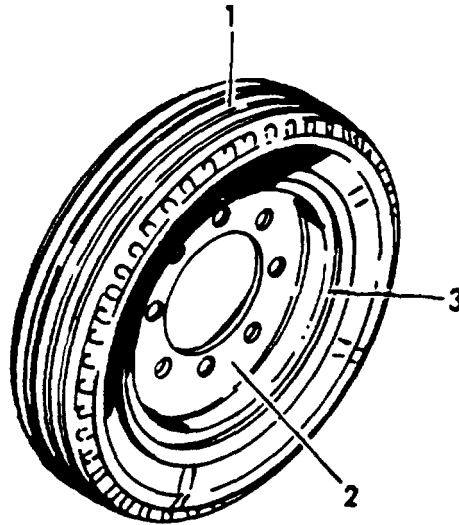

REF. NO.	PART NUMBER	DESCRIPTION	NO. REQ'D
TIRE & WHEEL ASSEMBLY - 11:00 x 20			
	6-970-000237	Tire & Wheel Assembly - General	
1	7-900-000112	Tire - 12 Ply	1
2	7-061-000034	Base, Rim	1
3	7-753-000337	Ring, Side	1
			6-970-000237

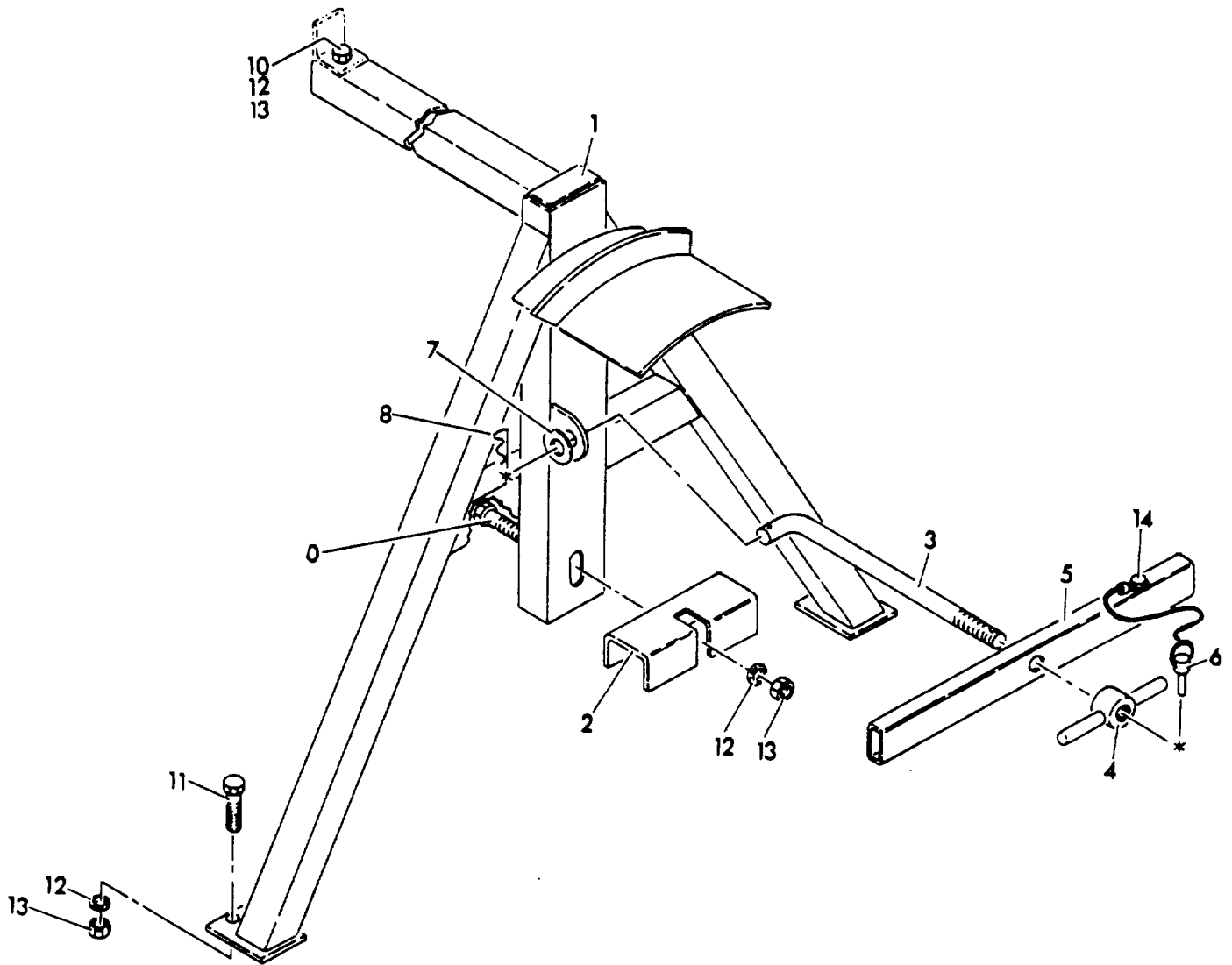

REF. NO.	PART NUMBER	DESCRIPTION	NO. REQ'D
----------	-------------	-------------	-----------

SPARE TIRE HANGER INSTALLATION

1	SK 772234	Spare Tire Hanger Weldment.....	1
2	6-846-000101	Spare Tire Holder Back Stop Weldment	1
3	SK 772241	Bolt.....	1
4	6-659-000138	Spare Tire Holder Nut Weldment	1
5	6-531-000041	Holder	1
6	7-689-000288	Pin, Detent Ball-Lok.....	1
7	MS27183-24	Flatwasher 2" O.D. x 13/16" I.D. x .148 Thick - Steel.....	1
8	7-689-000053	Pin, Clip	1
10	MS90725-119	Bolt, Hex Head 1/2"-13 N.C. x 3" Lg. Grd.I.....	2
11	MS90725-113	Bolt, Hex Head 1/2"-13 N.C. x 1 1/2" Length - Grade 1.....	2
12	MS35338-48	Lockwasher 1/2" Medium - Spring Steel.....	4
13	MS51967-14	Nut 1/2"-13 N.C. - Grade A.....	4
14	7-790-06053	Screw, Hex Washer Head Self-Tapping #6-32 x 3/8" Length.....	1

SK 772208

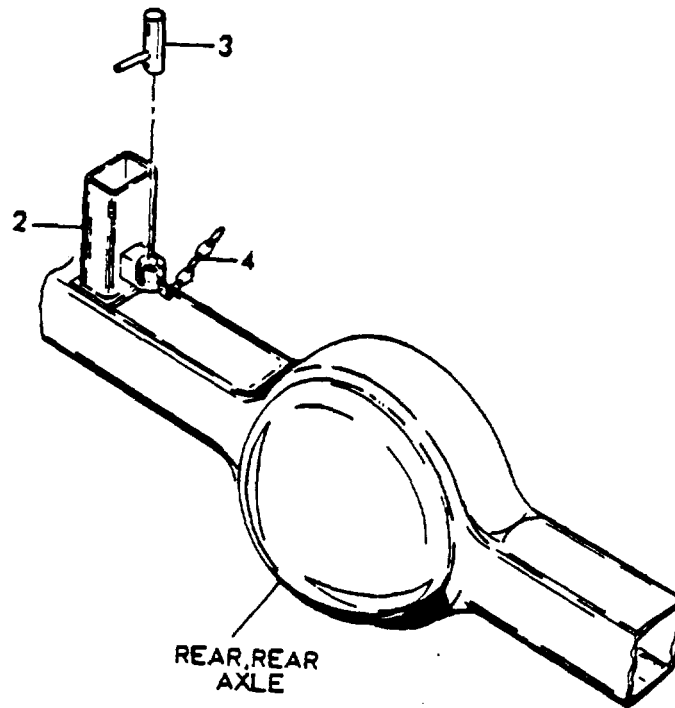

REF. NO.	PART NUMBER	DESCRIPTION	NO. REQ'D
AXLE STOP INSTALLATION			
1	SK 772323	Plate.....	2
2	SK 772308	Axle Stop Weldment	2
3	SK 772311	Handle Weldment	2
4	SK 772324	Chain	2

SK 772325

B-73/(B-73,1 Blank)

**ADDENDUM B
PARTS CATALOG
(CARRIER)**

FRAME GROUP

B-73.2

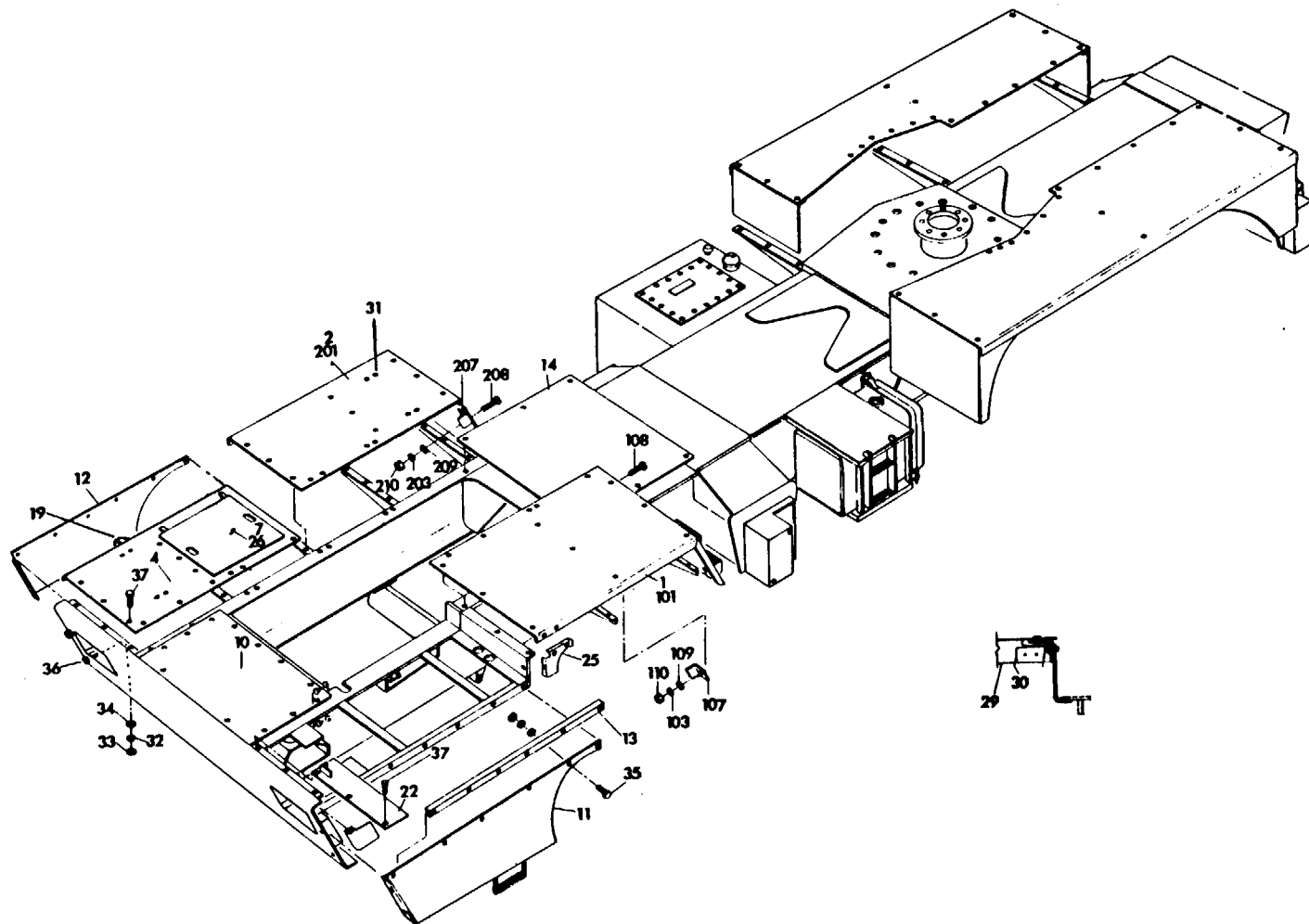

2-130-1-00100

B-74

REF. NO.	PART NUMBER	DESCRIPTION	NO. REQ'D
FRONT FENDERS & BATTERY BOX ASSEMBLY & INSTALLATION			
1	2-130-1-00057	L.H. Front Fender Weldment & Assembly - Consists of Items 101 Thru 110 -----	1
2	2-130-1-00058	R.H. Front Fender Weldment & Assembly - Consists of Items 201 Thru 210-----	1
4	2-130-1-00101	R.H. Front Fender & Battery Box Weldment -----	1
7	6-637-000008	Moulding -----	1
10	6-258-000397	Cover, Front -----	1
11	4-130-1-00051	Skirt, L.H. Fender-----	1
12	4-130-1-00147	Skirt, R.H. Fender -----	1
13	4-130-1-00057	Angle-----	1
14	4-130-1-00089	Decking, Frame -----	1
19	4-177-1-00243	Angle, Support -----	1
22	4-130-1-00056	Plate, Front Fill-----	1
25	4-130-1-00068	Plate, Corner-----	1
26	2-177-1-00101	Cover Weldment-----	1
29	6-030-001211	Angle-----	1
30	6-030-001212	Angle-----	2
31	7-242-000019	Button, Plug-----	8
32	MS35338-44	Lockwasher 1/4" Dia. - Medium - Spring Steel -----	41
33	MS51967-2	Nut, Hex 1/4"-20 N.C. - Grade A -----	41
34	MS27183-9	Flatwasher 1/4" Dia. - Type A - Steel -----	41
35	MS35751-15	Bolt, Square Neck 1/4"-20 x 3/4" Length - Grade 1 -----	23
36	MS35751-16	Bolt, Square Neck 1/4"-20 x 1" Length - Grade 1 -----	18
37	MS24629-59	Screw, Self-Drilling 1/4"-20 x 3/4" Length - Grade 1 -----	26
(B)			
101	4-130-1-00087	L.H. Front Fender -----	1
103	MS35338-44	Lockwasher 1/4" Dia. - Medium - Spring Steel -----	9
107	4-137-1-00352	Clip -----	3
108	MS35751-15	Bolt, Round Head Short Neck 1/4"-20 N.C. x 3/4" Length - Grade 1-----	9
109	MS27183-9	Flatwasher 1/4" Dia. - Type A - Steel-----	9
110	MS51967-2	Nut, Hex 1/4"-20 N.C. - Grade A-----	9
(F)			
201	4-130-1-00086	R.H. Front Fender 1	
203	MS35338-44	Lockwasher 1/4" Dia. - Medium - Spring Steel -----	9

REF. NO.	PART NUMBER	DESCRIPTION	NO. REQ'D
FRONT FENDERS & BATTERY BOX ASSEMBLY & INSTALLATION			
207	4-137-1-00352	Cip -----	3
208	MS35751-15	Bolt, Round Head Short Neck 1/4"-20 N.C. x 3/4" Length - Grade 1-----	9
209	MS27183-9	Flatwasher 1/4" Dia. - Type A - Steel-----	9
210	MS51967-2	Nut, Hex 1/4"--20 N.C. - Grade A -----	9

(F)

2-130-1-00100

Sheet 2 of 2

B-76

REF. NO.	PART NUMBER	DESCRIPTION	NO. REQ'D
REAR FENDER INSTALLATION			
1	6-431-000034	L.H. Fender Weldment & Assembly -----	1
2	2-130-1-00047	R.H. Fender Weldment & Assembly -----	1
9	MS35751-15	Bolt, Round Head Square Neck - 1/4"-20 N.C x 3/4" Lg. - Grade 1 -----	30
10	MS27183-9	Flatwasher - 1/4" Diameter - Type A - Steel -----	30
11	MS35338-44	Lockwasher - 1/4" Diameter - Medium - Spring Steel -----	30
12	MS51967-2	Nut, Hex - 1/4"-20 N.C. - Grade A -----	30

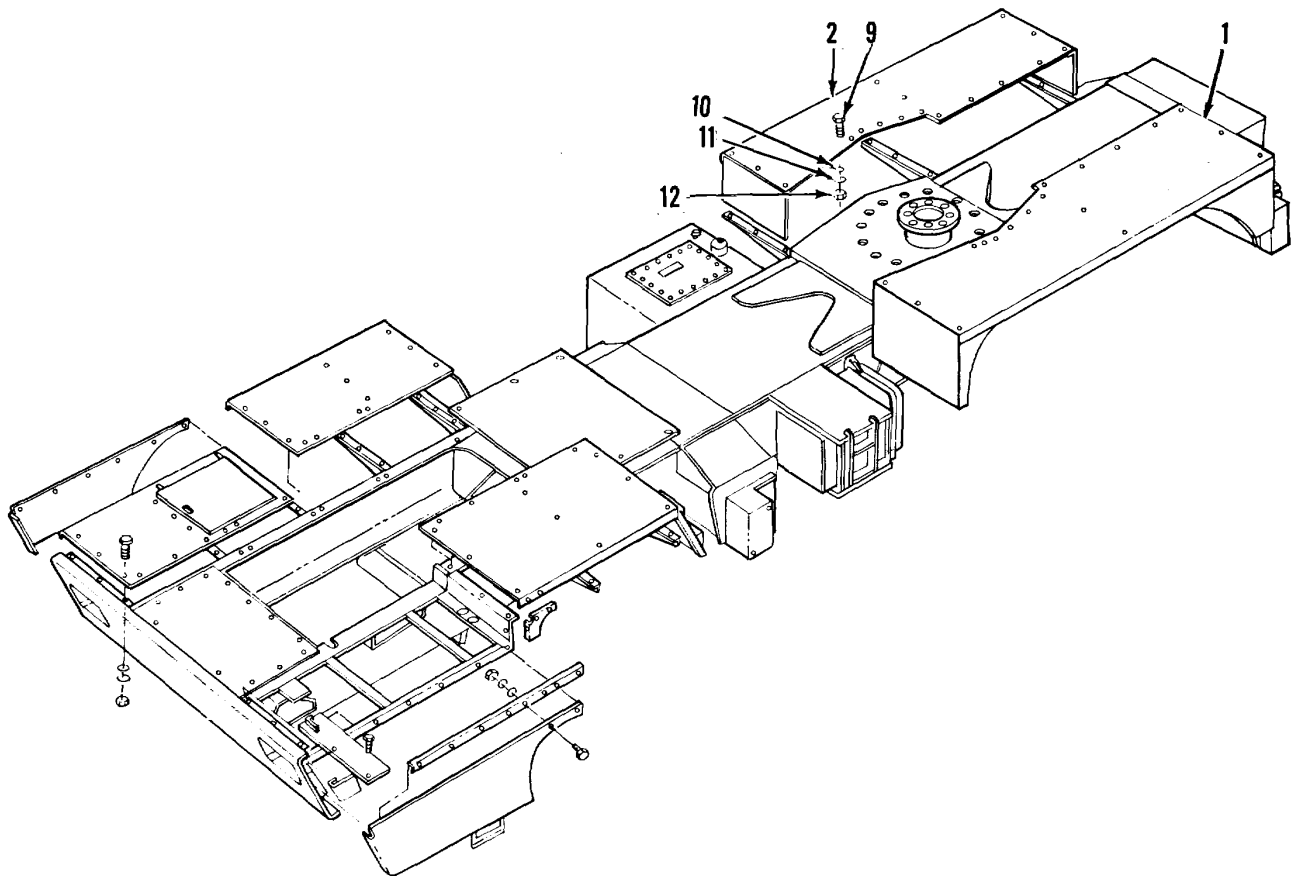

2-130-1-00026

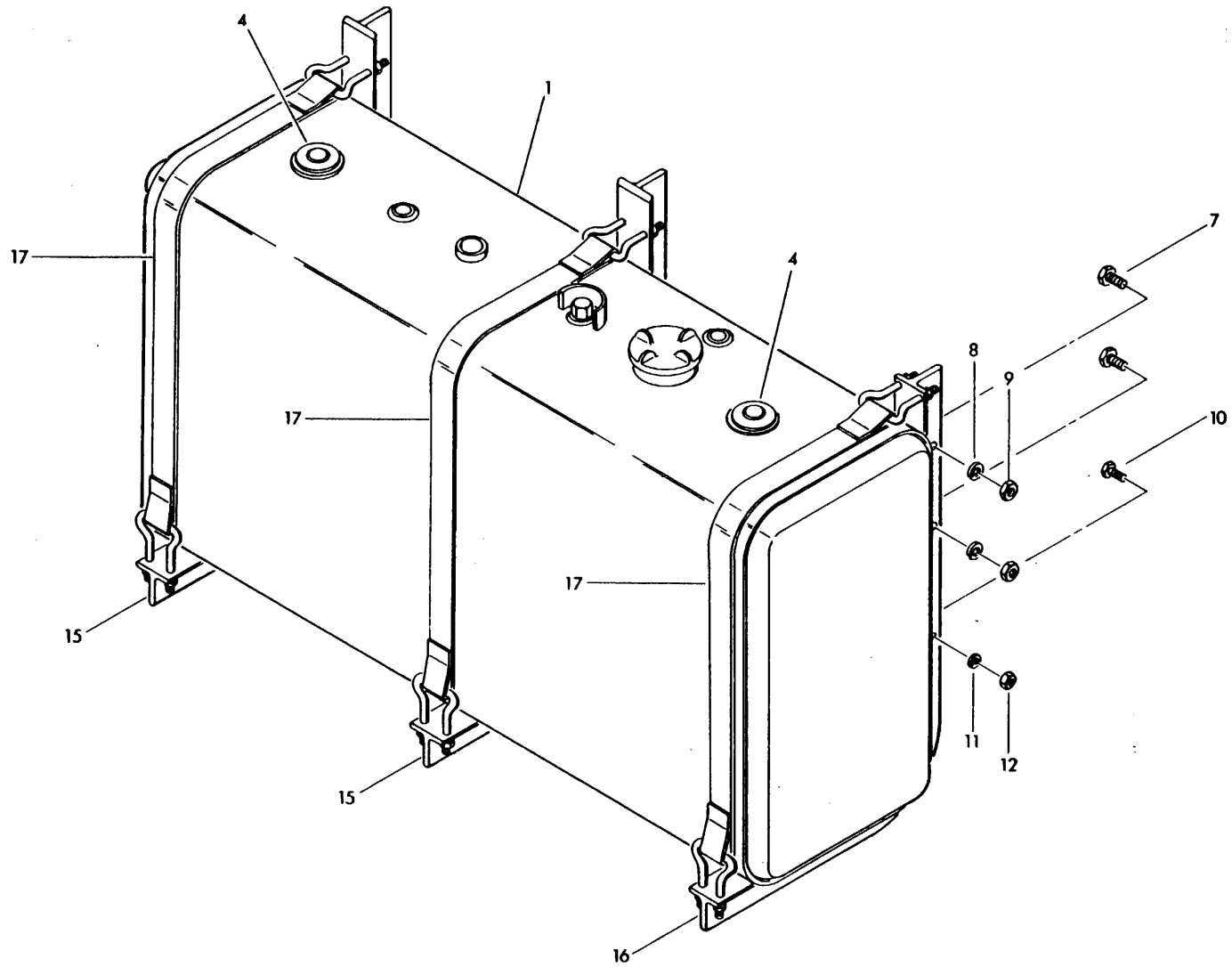

6-294-001140

B-78

REF. NO.	PART NUMBER	DESCRIPTION	NO. REQ'D
FUEL TANK INSTALLATION			
1	7-880-000029	Fuel Tank-----	1
4	4-150-8-00085	Sender, Fuel Level-----	2
7	MS90725-162	Bolt, Hex Head 5/8"-11 N.C. x 1 1/2" Lg. - Grade 1-----	6
8	MS35338-50	Lockwasher 5/8" Medium Spring Steel-----	6
9	MS51967-20	Nut, Hex 5/8"-11 N.C. - Grade A -----	6
10	MS90725-113	Bolt, Hex Head 1/2"-13 N.C. x 1 1/2" Lg. - Grade 1-----	3
11	MS35338-48	Lockwasher 1/2" Medium Spring Steel-----	3
12	MS51967-14	Nut, Hex 1/2"-13 N.C. - Grade A -----	3
15	7-184-000630	Bracket Assembly -----	2
16	7-184-000629	Bracket Assembly -----	1
17	7-850-000112	Strap Assembly -----	2

6-294-001140
2-130-8-00042 (C)

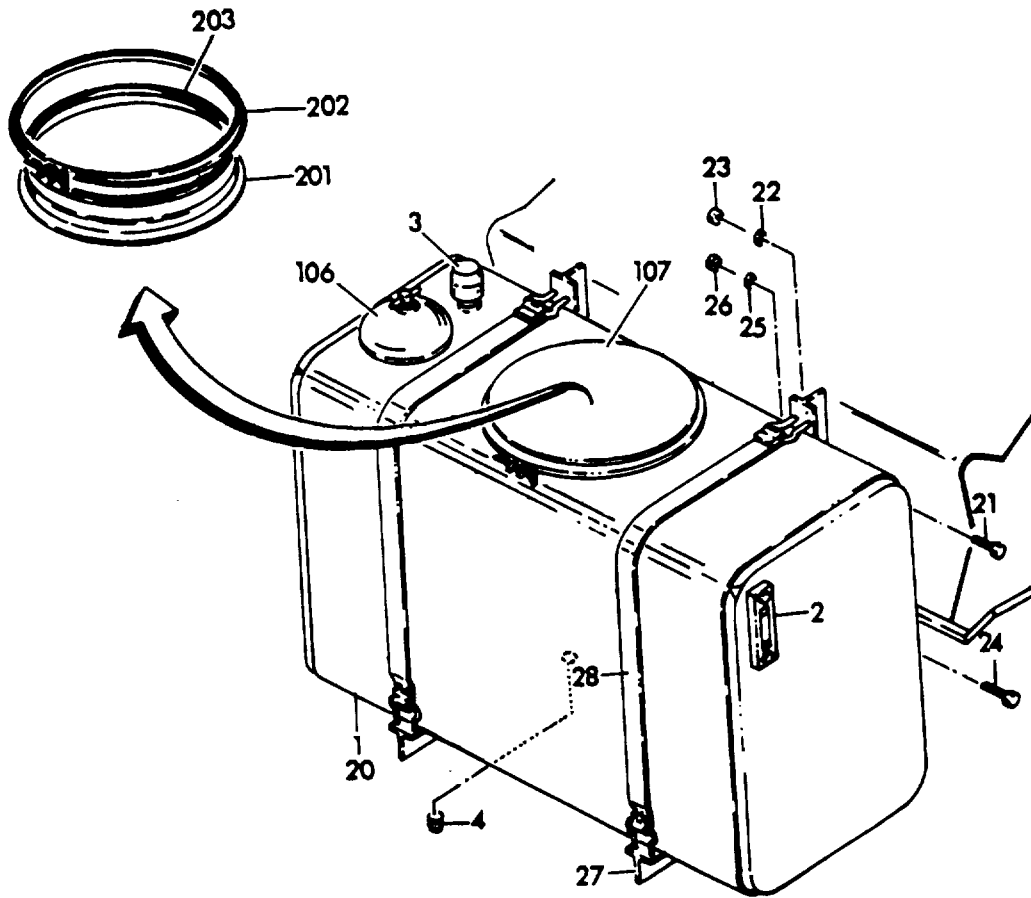

HYDRAULIC RESERVOIR ASSEMBLY & INSTALLATION

1	6-880-000099	Hydraulic Reservoir Weldment-Consist of Items 106 & 107 -----	1
2	7-486-000628	Gauge, Oil Level-----	1
3	7-258-000063	Cap, Breather-----	1
4	7-709-000072	Plug, Magnetic Pipe-----	1
20	6-880-000101	Hydraulic Reservoir Assembly-Consist of Items 1 thru 4-----	1
21	MS90725-113	Bolt, Hex Head 5/8"-11 N.C. x 1 1/2" Length-Grade 1 -----	4
22	MS 35338-50	Lockwasher 5/8" Medium-Spring Steel-----	4
23	MS 51967-20	Nut, Hex 5/8"-11 N.C.-Grade A -----	4
24	MS90725-113	Bolt, Hex Head 1/2"-13 N.C. x 1 1/2" Length-Grade 1 -----	2
25	MS35338-48	Lockwasher 1/2" Medium-Spring Steel -----	2
26	MS51967-14	Nut, Hex 1/2"-13 N.C.-Grade A-----	2
27	7-184-000817	"T" Bar Bracket-----	2
28	7-850-000129	Strap Assembly -----	2

6-880-000100

REF. NO.	PART NUMBER	DESCRIPTION	NO. REQ'D
HYDRAULIC RESERVOIR ASSEMBLY & INSTALLATION			
106	6-437-000057	Filter, Sub-Assembly -----	1
107	7-258-000409	Cover Assembly - Consists of Items 201, 202 & 203 -----	1
201	9-437-100223	Cover -----	1
202	9-437-100224	"O" Ring-----	1
203	9-437-100225	Clamp Assembly-----	1

6-880-000100

Sheet 2 of 2

B-81

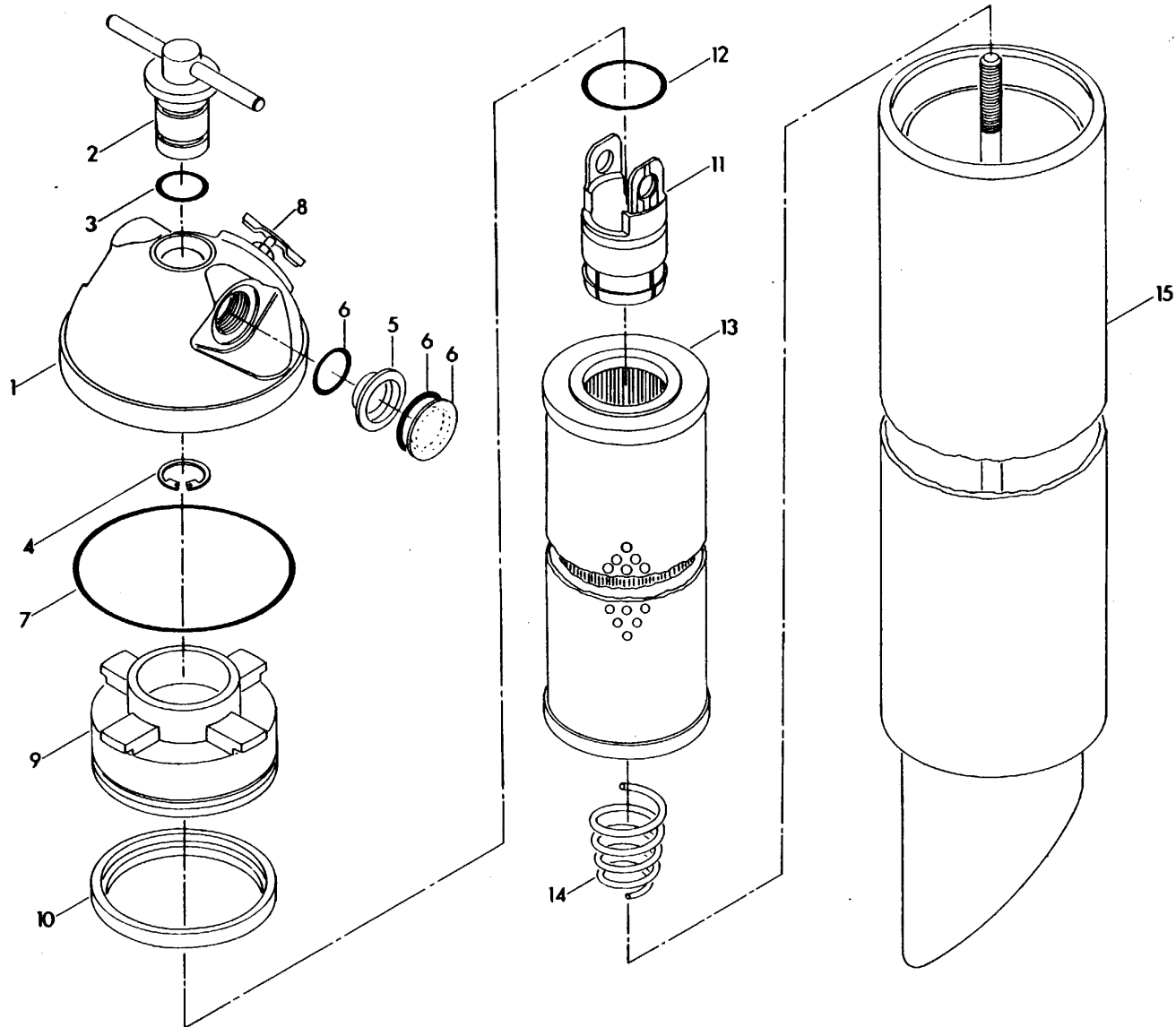

6-437-000057

B-82

REF. NO.	PART NUMBER	DESCRIPTION	NO. REQ'D
		HYDRAULIC OIL FILTER	
	6-437-000057	Hydraulic Oil Filter	
1	9-437-100141	Head Ass'y. (Includes Items 2 thru 8-----	1
2	9-437-100142	Nut Ass'y.-----	1
3	9-437-100143	O-Ring-----	1
4	9-437-100144	Ring, Retaining-----	1
5	9-437-100212	Window Ass'y. (Includes Item 6-----	1
6	9-437-100217	Window Ass'y. Kit-----	1
7	9-437-100150	O-Ring-----	1
8	9-437-100151	Valve, Bleed-- -----	1
9	9-437-100185	Baffle Ass'y. (Includes Item 10 -----	1
10	9-437-100215	Seal, Cup -----	1
11	9-437-100186	Indicator Ass'y; (By Pass ----- (Includes Item 12)	1
12	9-437-100155	O-Ring-----	1
13	9-437-100156	Element Ass'y -----	1
14	9-437-100157	Spring (25 P.S.I.)-----	1
15	9-437-100218	Body Ass'y. -----	1

6-437-000057

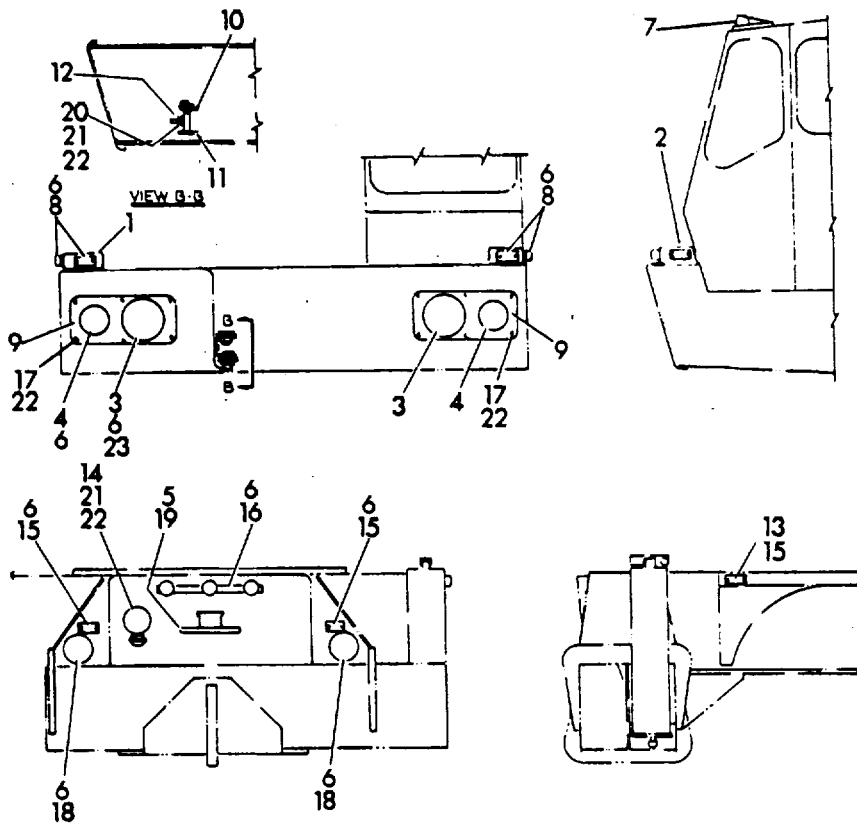

REF. NO.	PART NUMBER	DESCRIPTION	NO. REQ'D
EXTERIOR LIGHTS & HORN INSTALLATION			
1	6-184-000826	Bracket, R.H. Light -----	1
2	6-184-000825	Bracket, L.H. Light-----	1
3	7-581-000070	Headlight Assembly-----	2
	9-581-100023	Lamp -----	2
4	7-581-000069	Turnsignal -----	2
	9-581-100033	Bulb -----	2
5	MS24625-43	Screw, Truss Head Self-Tapping #10-16 x 1/2" Length -----	2
6	MS24629-48	Screw, Round Head Self-Tapping #10-24 x 3/4" Length -----	48
7	7-581-000072	Lamp, Identification -----	3
	7-581-000004	Bulb -----	3
8	6-581-000178	Light, Clearance & Marker -----	6
	7-581-000161	Clearance & Marker Light (Amber)-----	1 Per Ass'y.
	7-345-001831	Shur Plug -----	1 Per Ass'y.
	9-581-100036	Bulb -----	2 Per Ass'y.
9	4-177-1-00246	Plate, Mounting Headlight-----	2
10	7-025-000015	Horn, Hi-Tone -----	1
11	7-025-000005	Horn, Lo-Tone -----	1
12	7-750-000015	Relay, Horn -----	1
13	MS24629-47	Screw, Phillips Pan Head Self-Drilling #10 -24 N.C. x 5/8" Length -----	16

REF. NO.	PART NUMBER	DESCRIPTION	NO. REQ'D
EXTERIOR LIGHTS & HORN INSTALLATION			
14	7-581-000013	Light - Rear -----	1
	9-581-100030	Bulb -----	1
15	6-581-000177	Light, Clearance & Marker -----	4
	7-581-000162	Clearnace & Marker Light, Red -----	1 Per Ass'y.
	7-345-001831	Shur Plug -----	1 Per Ass'y.
	9-581-100036	Bulb -----	2 Per Ass'y.
16	7-581-000036	Lights, Triple Identification -----	1
	7-581-000004	Bulb -----	3
17	MS35206-280	Screw, Truss Head Machine 1/4"-20 N.C. x 5/8" Length - Grade 1 -----	12
18	7-581-000068	Light, Stop, Turn & Tail -----	2
	9-581-100035	Bulb -----	2
19	6-638-000115	Mount, License Plate -----	1
20		Nut, Hex 1/4"-20 N.C. - Grade A-----	4
21	MS90725-8	Bolt, Hex Head 1/4"-20 N.C. x 1" Length - Grade 1 -----	6
22	MS35338-44	Lockwasher 1/4" Medium - Spring Steel -----	18
23	MS35338-43	Lockwasher #10 Medium - Spring Steel -----	8

6-581-000182

Sheet 2 of 2

B-85

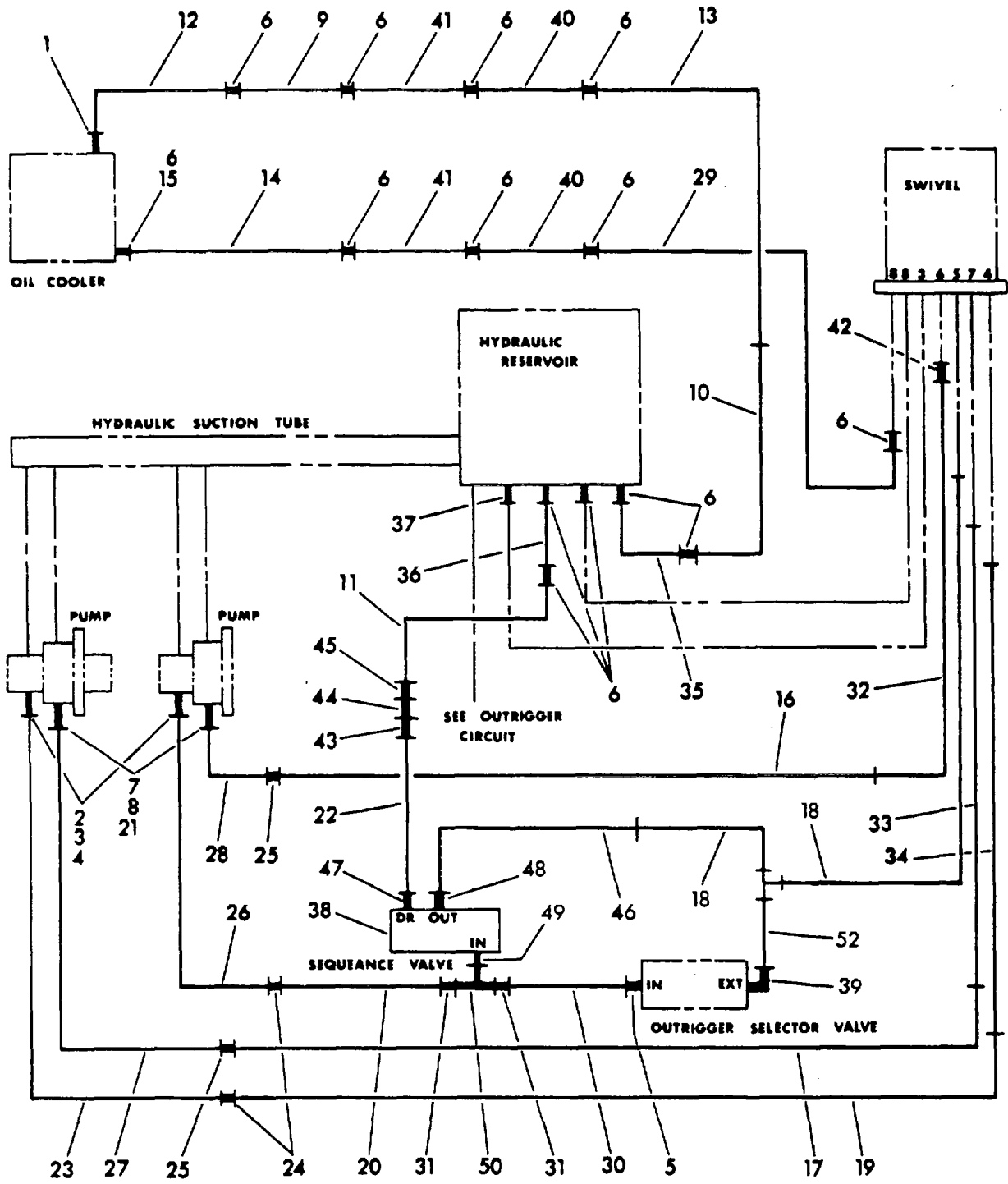

2-147-6-00075

REF. NO.	PART NUMBER	DESCRIPTION	NO. REQ'D
SUPPLY, PRESSURE & RETURN - HYDRAULIC SCHEMATIC			
1	7-445-242019	Adapter -----	1
2	MS90725-62	Bolt, Hex Head 3/8"-16 N.C. x 1 1/4" Length - Grade 5-----	8
3	MS35338-46	Lockwasher 3/8" Medium - Spring Steel -----	8
4	7-755-214000	"O" Ring-----	2
5	7-445-161443	Adapter-----	1
6	7-300-000035	Clamp, Hose -----	18
7	MS90725-87	Bolt, Hex Head 7/16"-14 U.N.C. x 1 1/4" Length - Grade 5-----	8
8	MS35338-47	Lockwasher 7/16" Medium - Spring Steel ----	8
9	6-540-705220	Hose -----	1
10	7-910-002796	Tube -----	1
11	7-910-002715	Tube -----	1
12	7-910-001005	Tube -----	1
13	7-910-002104	Tube -----	1
14	6-540-706420	Hose -----	1
15	7-910-001292	Tube -----	1
16	7-910-002797	Tube -----	1
17	7-910-002798	Tube -----	1
18	7-910-004252	Tube -----	1
19	7-910-002101	Tube -----	1
20	7-910-002103	Tube -----	1
21	7-755-222000	"O" Ring-----	2
22	7-910-003888	Tube -----	1
23	7-910-004063	Tube -----	1
24	7-445-161631	Adapter-----	2
25	7-445-202031	Adapter-----	2
26	7-910-004062	Tube -----	1
27	7-910-004064	Tube -----	1
28	7-910-004065	Tube -----	1
29	7-910-002102	Tube -----	1
30	7-910-002087	Tube -----	1
31	7-445-161219	Adapter-----	2
32	7-910-002100	Tube -----	1
33	7-910-002109	Tube -----	1
34	7-910-002098	Tube -----	1
35	6-540-700920	Hose -----	1
36	6-540-500910	Hose -----	1
37	7-300-000013	Clamp, Hose - -----	1
38	7-926-000797	Valve, Sequence-----	1
39	7-445-161445	Adapter, Swivel -----	1
40	6-540-705220	Hose -----	2
41	7-910-002242	Tube -----	2
42	7-445-161601	Adapter, Swivel -----	1
43	7-445-060819	Adapter-----	1
44	7-445-160850	Reducer-----	1
45	7-013-000292	Adapter-----	1
46	7-910-004253	Tube -----	1

REF. NO.	PART NUMBER	DESCRIPTION	NO. REQ'D
SUPPLY, PRESSURE & RETURN - HYDRAULIC SCHEMATIC			
47	7-445-060419	Adapter-----	1
49	7-445-121249	Nipple-----	1
50	7-445-121255	Tee -----	1
52	7-910-001868	Tube -----	1

2-147-6-00075 (A)

Sheet 2 of 2

B-88

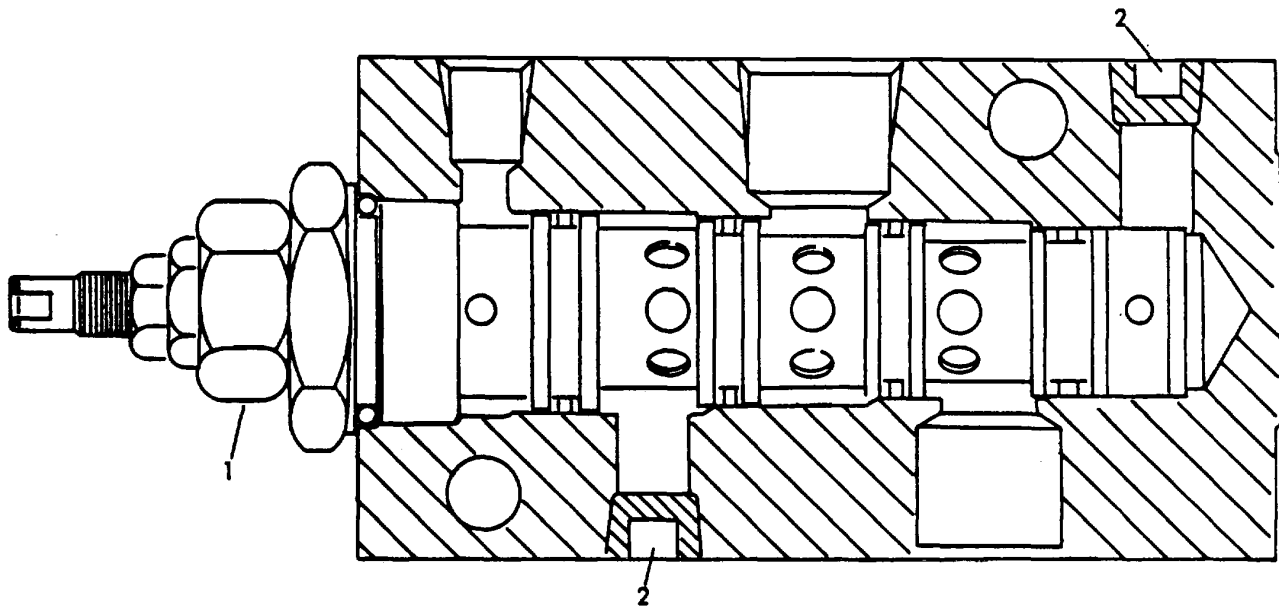

REF. NO.	PART NUMBER	DESCRIPTION	NO. REQ'D
		SEQUENCE VALVE ASSEMBLY	
	7-926-000797	Sequence Valve Assembly	
1	9-926-102359	Cartridge Assembly -----	1
2	9-926-102360	Plug, Pipe-----	2
	9-926-102361	Seal Kit-----	1

7-926-000797

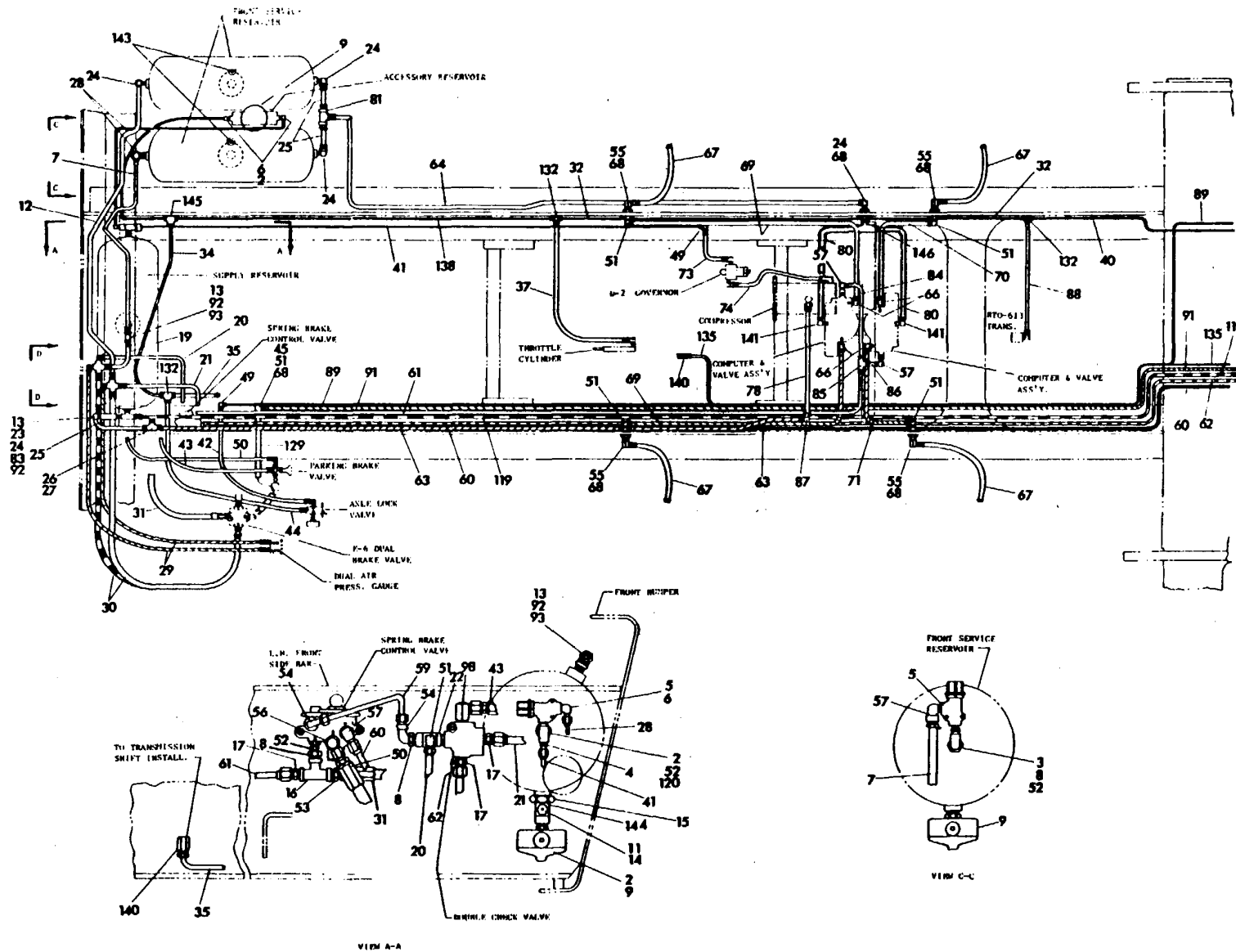

2-130-6-00067

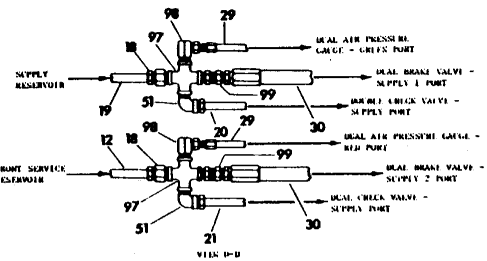
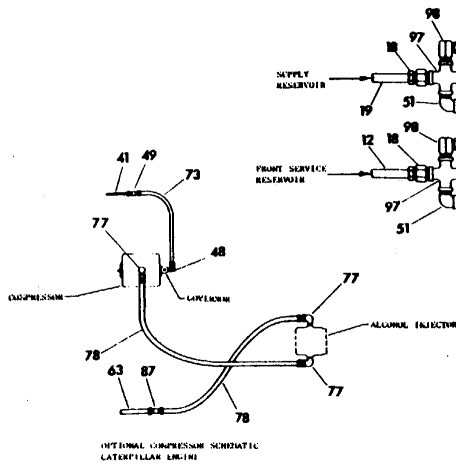
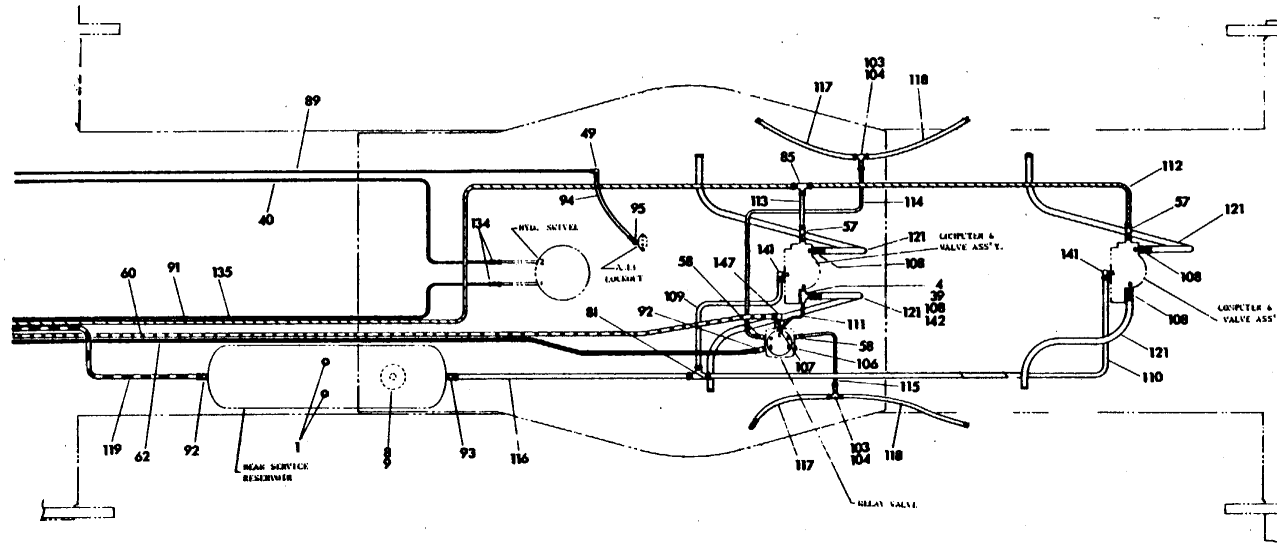

- CODE
- A SERVICE BRAKE PORT
 - B SERVICE PORT
 - C CONTROL PORT
 - D DELIVERY PORT
 - E EXHAUST PORT
 - S SUPPLY PORT
 - X BALANCE PORT
 - Z SPRING BRAKE PORT
 - R RESERVOIR PORT

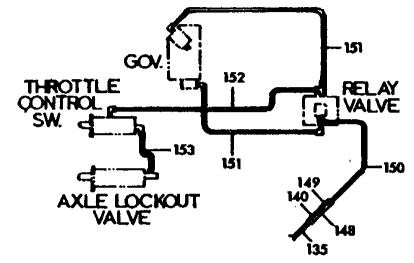

REF. NO.	PART NUMBER	DESCRIPTION	NO. REQ'D
AIR SYSTEM SCHEMATIC - G.M.C. ENGINE			
1	AN932-4	Plug, Hex Countersunk Head Pipe 3/8"- 18 N.P.T. -----	2
2	7-444-060256	Bushing, Hex Reducing -----	4
3	7-406-000180	Elbow, Street -----	1
4	7-446-040406	Connector, Male - -----	2
5	7-926-000487	Valve, Pressure Protection -----	2
6	7-446-060407	Elbow, Male - -----	3
7	6-911-084320	Tubing, Copper -----	1
8	7-444-040256	Bushing, Hex Reducing -----	3
9	7-926-000209	Valve, Auto-Drain -----	5
11	7-444-060356	Bushing, Hex Reducing - -----	1
12	6-911-105440	Tubing, Copper -----	1
13	7-888-000094	Tee, Male Branch -----	2
14	7-926-000210	Valve, Safety - -----	1
15	7-444-100656	Bushing, Hex Reducing - -----	1
16	7-888-000001	Tee -----	1
17	7-446-080806	Connector, Male - -----	3
18	7-446-100806	Connector, Male -----	2
19	6-911-102400	Tubing, Copper -----	1
20	6-911-081920	Tubing, Copper -----	1
21	6-911-081620	Tubing, Copper -----	1
22	7-888-000031	Tee, Service -----	1
23	7-926-000207	Valve, Single Check -----	1
24	7-446-100807	Elbow, Male - -----	5
25	6-911-100640	Tubing, Copper -----	3
26	7-446-100414	Tee, Female Branch -----	1
27	7-926-000273	Drain Cock -----	1
28	6-911-064000	Tube, Copper -----	2
29	7-542-008403	Hose -----	2
30	7-542-406015	Hose -----	2
31	7-542-204811	Hose -----	1
32	6-911-063300	Tube, Copper -----	1
34	6-911-062880	Tube, Copper -----	1
35	6-911-061920	Tube, Copper -----	1
37	AN932-3	Plug, Pipe - 1/4" Carbon Steel - -----	1
39	7-444-040256	Bushing, Hex Reducing -----	1
40	6-910-003378	Tube, Copper -----	1
41	6-910-001282	Tube, Copper -----	1
42	7-542-008403	Hose -----	1
43	7-542-109004	Hose -----	1
44	7-542-107604	Hose - -----	1
45	7-444-040356	Bushing, Hex Reducing -----	1
49	7-446-040404	Connector, Female -----	3
50	7-542-109004	Hose -----	1

2-130-6-00067

REF. NO.	PART NUMBER	DESCRIPTION	NO. REQ'D
AIR SYSTEM SCHEMATIC - G.M.C. ENGINE			
51	7-446-080807	Elbow, Male-----	8
52	7-445-040449	Nipple-----	3
53	7-445-080601	Adapter - ...-----	1
54	7-446-040407	Elbow, Male - -----	2
55	7-445-080604	Adapter-----	4
56	7-445-040404	Adapter-----	1
57	7-446-080407	Elbow, Male - -----	6
58	7-449-060807	Elbow, Male-----	3
59	6-911-040640	Tubing, Copper - -----	1
60	6-910-002758	Tubing, Copper - -----	1
61	6-911-088960	Tube, Copper-----	1
62	6-910-003109	Tubing, Copper - -----	1
63	6-911-108000	Tubing, Copper-----	1
64	6-911-109120	Tube, Copper-----	1
66	7-446-080807	Elbow, Male - -----	4
67	7-542-203611	Hose-----	4
68	7-364-000425	Adapter, Bulkhead-----	6
69	6-911-083720	Tubing, Copper - -----	2
70	6-911-084000	Tubing, Copper - -----	1
71	6-911-083360	Tubing, Copper - -----	1
73	7-542-001803	Hose-----	1
74	7-542-001803	Hose-----	1
78	7-543-000629	Hose-----	1
80	6-911-102400	Tubing, Copper-----	2
81	7-446-101002	Tee - -----	2
83	7-406-000172	Elbow, Male Pipe - -----	1
84	6-911-081120	Tubing, Copper - -----	1
85	7-446-080802	Tee-----	2
86	6-911-080480	Tube, Copper-----	1
87	7-446-100809	Elbow, Female-----	1
88	7-542-003003	Hose-----	1
89	6-910-002762	Tubing, Copper - -----	1
91	6-910-002760	Tubing, Copper - -----	1
92	7-446-081206	Connector, Male - -----	4
93	7-446-101206	Connector, Male - -----	2
94	7-542-003603	Hose-----	1
95	7-445-040409	Adapter-----	1
97	7-445-080856	Cross-----	2
98	7-445-080404	Adapter-----	3
99	7-445-080801	Adapter - -----	2
103	7-445-060655	Tee-----	2
104	7-446-060606	Connector, Male-----	2
106	AN932-6	Plug, Hex Countersunk Head Pipe 3/4"-14 N.P.T-----	1

2-130-6-00067

REF. NO.	PART NUMBER	DESCRIPTION	NO. REQ'D
AIR SYSTEM SCHEMATIC - G.M.C. ENGINE			
107	7-446-040207	Elbow, Male - -----	1
108	7-445-080809	Elbow, Swivel-----	4
109	6-911-102080	Tubing, Copper-----	1
110	6-911-105440	Tubing, Copper - -----	1
111	6-911-040800	Tubing, Copper - -----	1
112	6-911-085120	Tubing, Copper - -----	1
113	6-911-082240	Tubing, Copper-----	1
114	6-911-063600	Tubing, Copper-----	1
115	6-911-061440	Tubing, Copper - -----	1
116	6-911-103600	Tubing, Copper - -----	1
117	7-542-102405	Hose -----	2
118	7-542-103005	Hose -----	2
119	6-910-002761	Tubing, Copper-----	1
120	7-888-000033	Tee, Service - -----	1
121	7-542-303606	Hose -----	4
122	7-866-142140	Stud Weldment - -----	A/R
123	MS51967-2	Nut, Hex 1/4"-20 N.C. - Grade A -----	A/R
124	MS35338-44	Lockwasher 1/4" Medium - Spring Steel -----	A/R
125	7-300-000098	Clamp, Tubing - -----	A/R
126	7-300-000100	Clamp, Tubing - -----	A/R
127	7-300-000101	Clamp, Tubing -----	A/R
128	7-300-000102	Clamp, Tubing - -----	A/R
129	7-542-201811	Hose -----	1
132	7-446-060414	Tee, Female Branch - -----	3
134	7-446-060601	Union -----	2
135	6-910-001902	Tubing, Copper-----	1
138	6-911-067680	Tubing, Copper - -----	1
140	7-446-060404	Connector, Female-----	2
141	7-446-101206	Elbow, Male - -----	4
142	7-888-000031	Tee, Service - -----	1
143	AN932-3	Plug, Pipe Hex Countersunk 1/4"-18 N.P.T.- -----	2
144	7-888-000037	Tee, Service -----	1
145	7-446-060602	Tee, Union-----	1
146	7-446-100811	Tee, Male - -----	1
147	7-446-080406	Connector, Male -----	1
148	7-444-040250	Bushing, Hex Reducing -----	1
149	7-364-000641	Connector, Male -----	1
150	6-912-021200	Tube - -----	1
151	6-912-020240	Tube -----	2
152	6-912-023560	Tube -----	1
153	6-912-020340	Tube -----	1

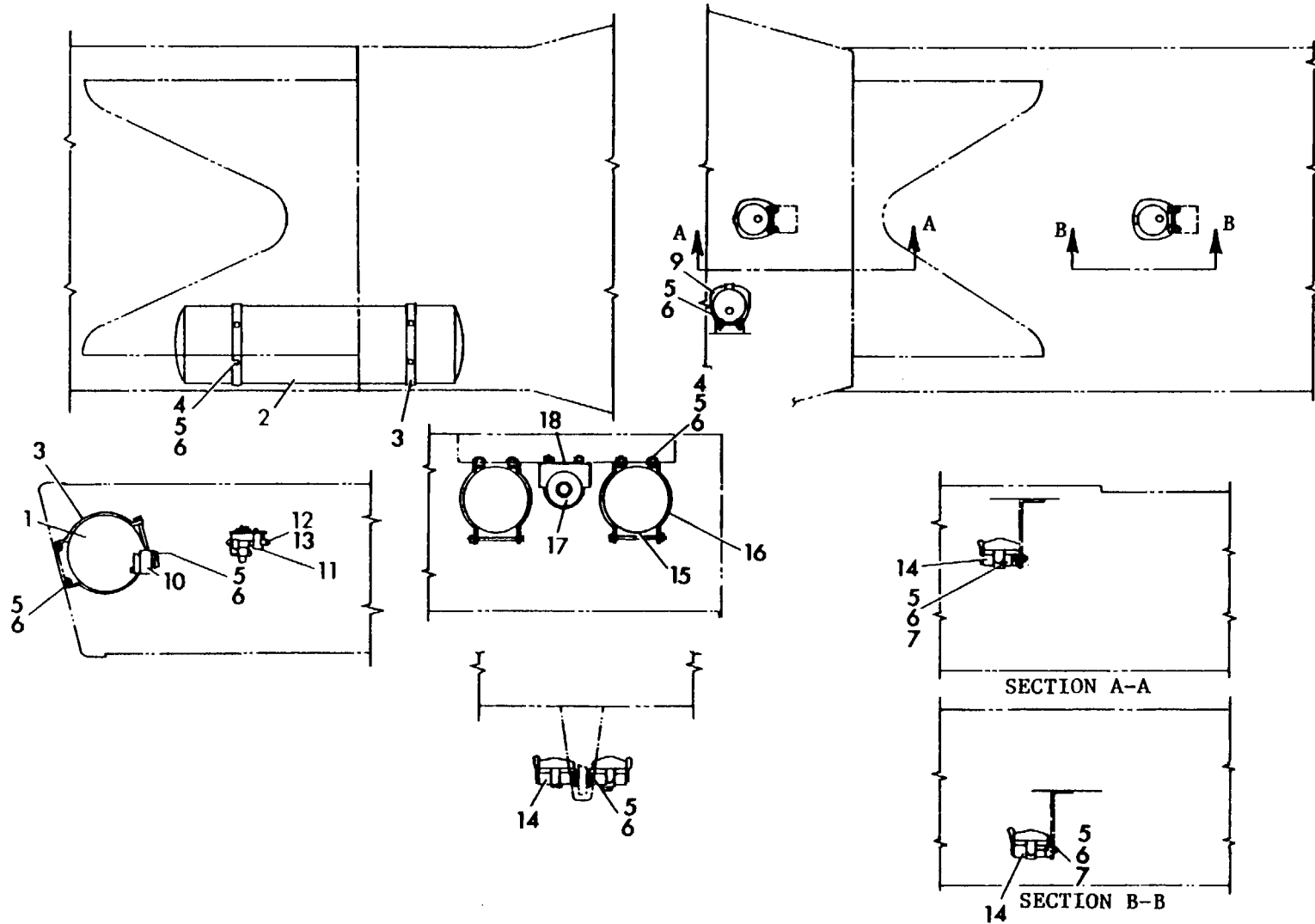

REF. NO.	PART NUMBER	DESCRIPTION	NO. REQ'D
AIR TANK INSTALLATION			
1	7-880-000018	Air Reservoir- -----	1
2	7-880-000019	Air Reservoir - -----	1
3	7-184-000189	Brackets -----	1
4	MS90725-60	Bolt, Hex Head - 3/8"-16 N.C. x 1" Lg. - Grade 1 -----	12
5	MS35338-46	Lockwasher - 3/8" Medium - Spring Steel -----	27
6	MS51967-8	Nut, Hex - 3/8"-16 N.C. - Grade A- -----	27
7	MS90725-62	Bolt, Hex Head - 3/8"-16 N.C. x 1 1/4" Lg. - Grade 1- -----	4
9	7-926-000631	Valve, Relay- - -----	1
10	7-926-000216	Valve, Double Check- - -----	1
11	7-926-000608	Valve, Spring Brake Control -----	1
12	MS35338-45	Lockwasher - 5/16" Medium - Spring Steel -----	2
13	MS51967-5	Nut, Hex - 5/16"-18 N.C. - Grade A -----	2
14	7-926-000619	Valve, Relay- -----	4
15	7-880-000011	Reservoir -... -----	2
16	7-184-000106	Bracket, Reservoir-----	4
17	7-880-000020	Reservoir- -----	1
18	7-300-000036	Clamp, Muffler -----	2

6-880-000056 (B)

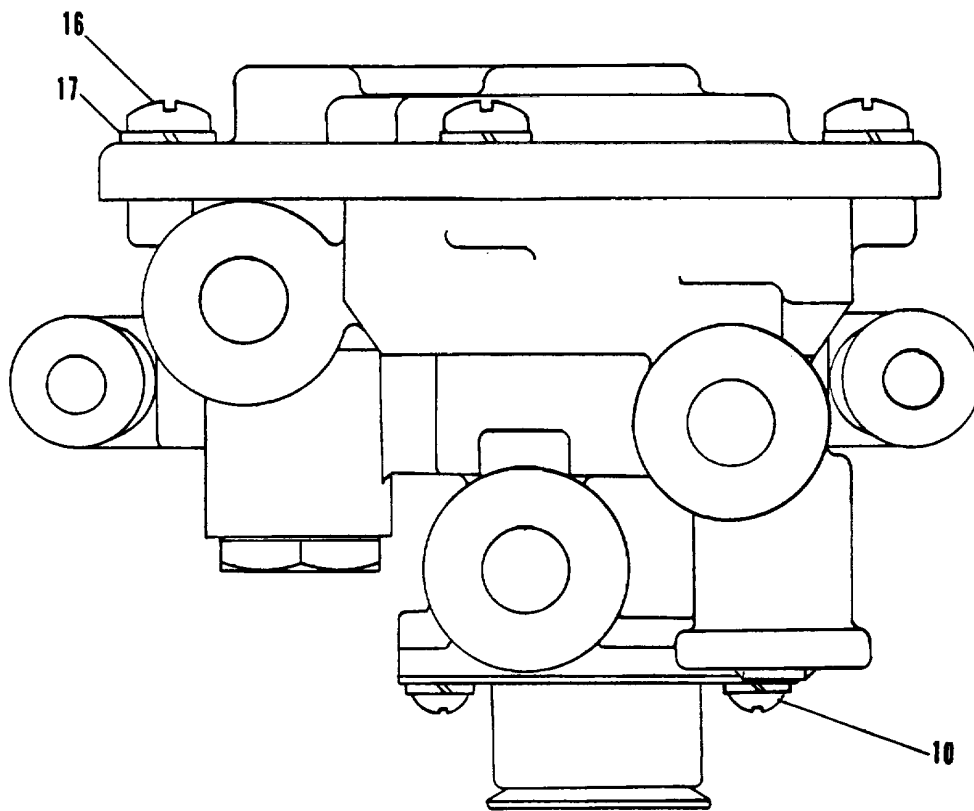
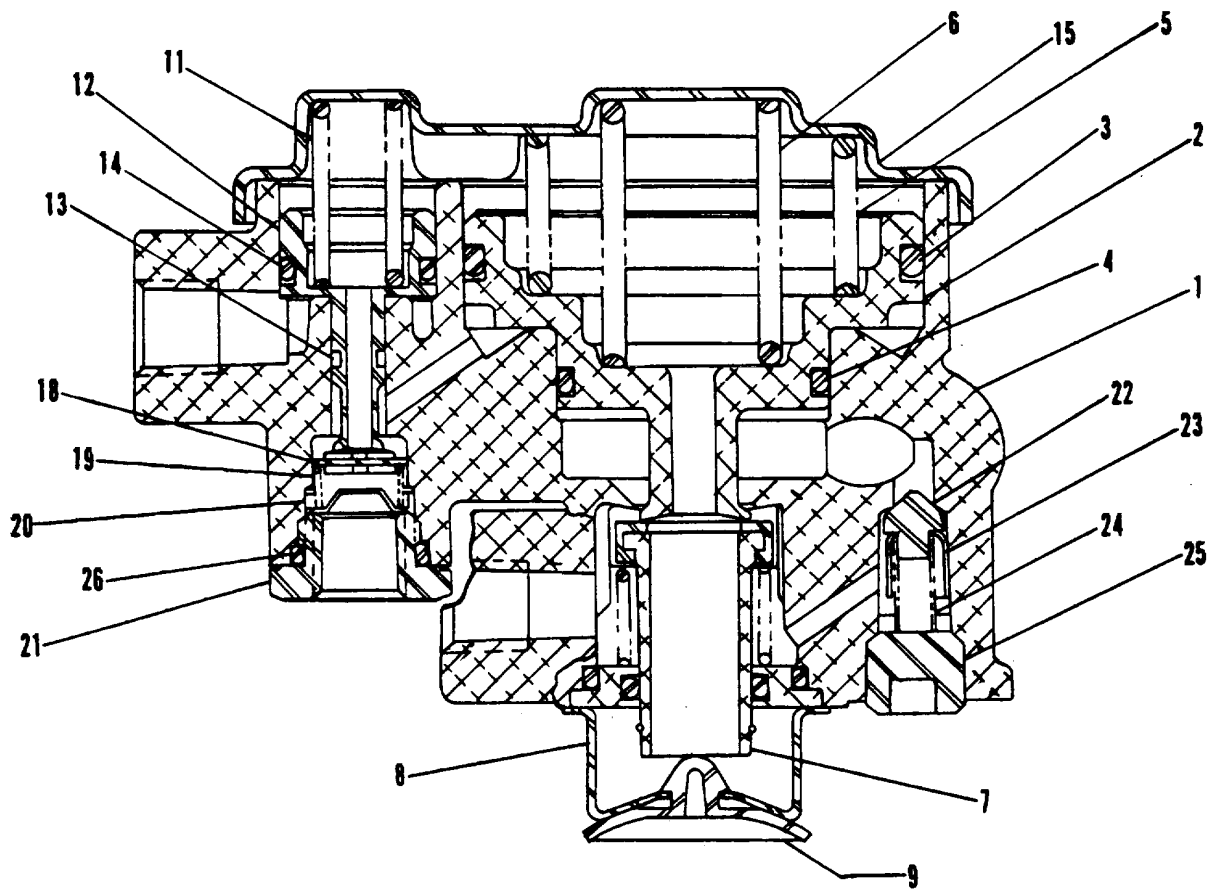

REF. NO.	PART NUMBER	DESCRIPTION	NO. REQ'D
		SPRING BRAKE VALVE ASSEMBLY	
	7-926-000608	Spring Brake Valve	
1	9-926-101637	Body -----	1
2	9-926-101638	Piston -----	1
*3	9-926-101639	"O" Ring - Large- -----	1
*4	9-926-101640	"O" Ring - Small -----	1
*5	9-926-101641	Spring, Piston -----	1
*6	9-926-101642	Spring, Piston -----	1
*7	9-926-101643	Inlet & Exhaust Valve Assembly -----	1
8	9-926-101305	Cover, Exhaust -----	1
*9	9-926-101304	Diaphragm- -----	1
10	9-926-101644	Screw, Machine w/Washer - -----	2
*11	9-926-101645	Spring, Piston -----	1
12	9-926-101646	Piston -----	1
*13	9-926-101647	"O" Ring - Small- -----	1
*14	9-926-101627	"O" Ring - Large - -----	1
15	9-926-101648	Cover- -----	1
16	9-926-101649	Screw- -----	4
17	9-332-100036	Lockwasher -----	4
*18	9-926-101650	Valve - Includes Insert -----	1
*19	9-926-101651	Spring, Valve- -----	1
*20	9-926-101652	Stop, Valve- -----	1
21	9-926-101653	Nut, Cap -----	1
*22	9-926-101654	Valve, Check- -----	1
23	9-926-101655	Guide, Spring- -----	1
*24	9-926-101656	Spring, Check Valve- -----	1
25	9-926-101657	Plug, Pipe- -----	1
*26	7-755-114000	"O" Ring- -----	1
	9-752-100183	Repair Kit	

*Items Included In Repair Kit

7-926-000608

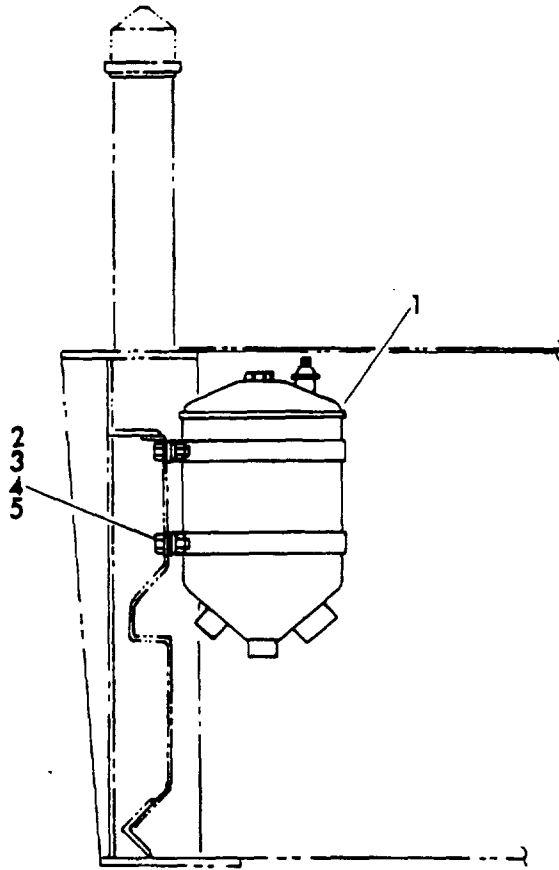

REF. NO.	PART NUMBER	DESCRIPTION	NO. REQ'D
POWER STEERING RESERVOIR INSTALLATION			
1	7-880-000102	Reservoir, Power Steering - -----	1
2	MS90726-58	Bolt, Hex Head 3/8"-24 N.F. x 3/4" Length - Grade 1 -----	4
3	MS27183-15	Flatwasher 7/16" I.D. x 1" O.D. x .083 thick - Steel -----	4
4	MS35338-46	Lockwasher 3/8" Medium - Spring Steel - -----	4
5	MS51968-8	Nut, Hex 3/8"-24 N.F. - Grade A - -----	4

6-880-000116

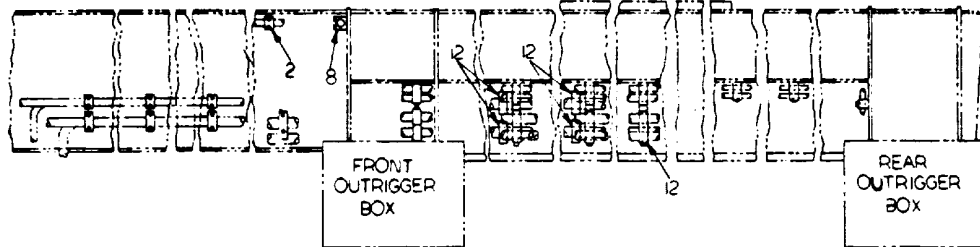
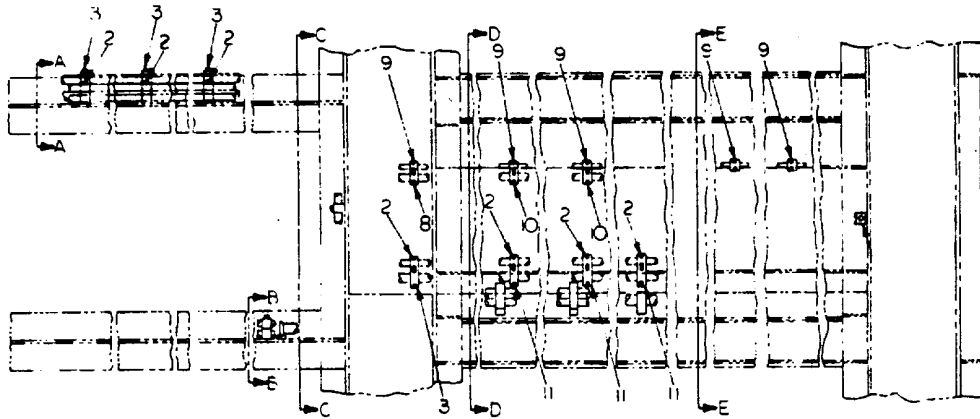
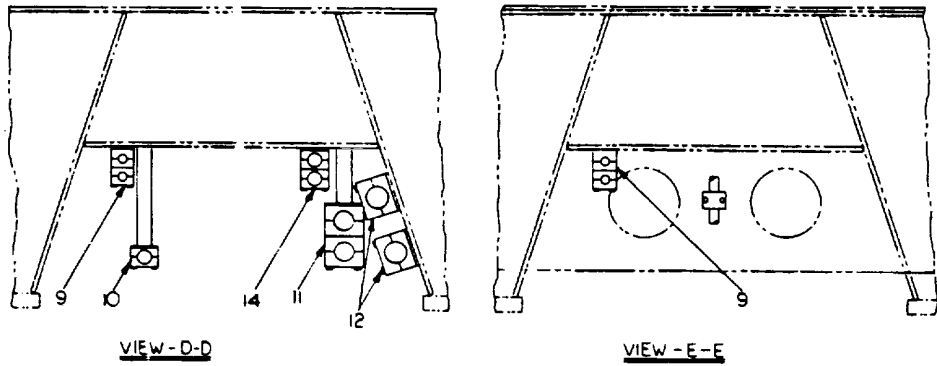
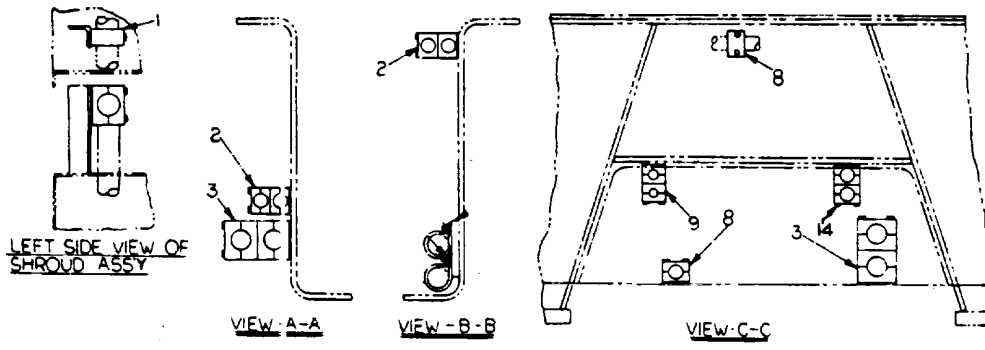

REF. NO.	PART NUMBER	DESCRIPTION	NO. REQ'D
TUBE SUPPORT INSTALLATION (CARRIER)			
1	2-137-6-00024	Tube Support Weldment-----	1
2	7-312-000041	Clip, Pipe - 1"-----	2
3	7-312-000032	Clip, Pipe - 1 1/4"-----	3
8	7-312-000027	Clip, Pipe - 1"-----	2
9	7-312-000039	Clip, Pipe - 5/8"-----	5
10	2-147-6-00035	Tube Support Weldment-----	2
11	2-147-6-00036	Tube Support Weldment-----	3
12	7-312-000026	Clip, Pipe - 1 1/2"-----	3
14	2-147-6-00048	Tube Support Weldment-----	4

2-147-6-00037 (D)

B-101

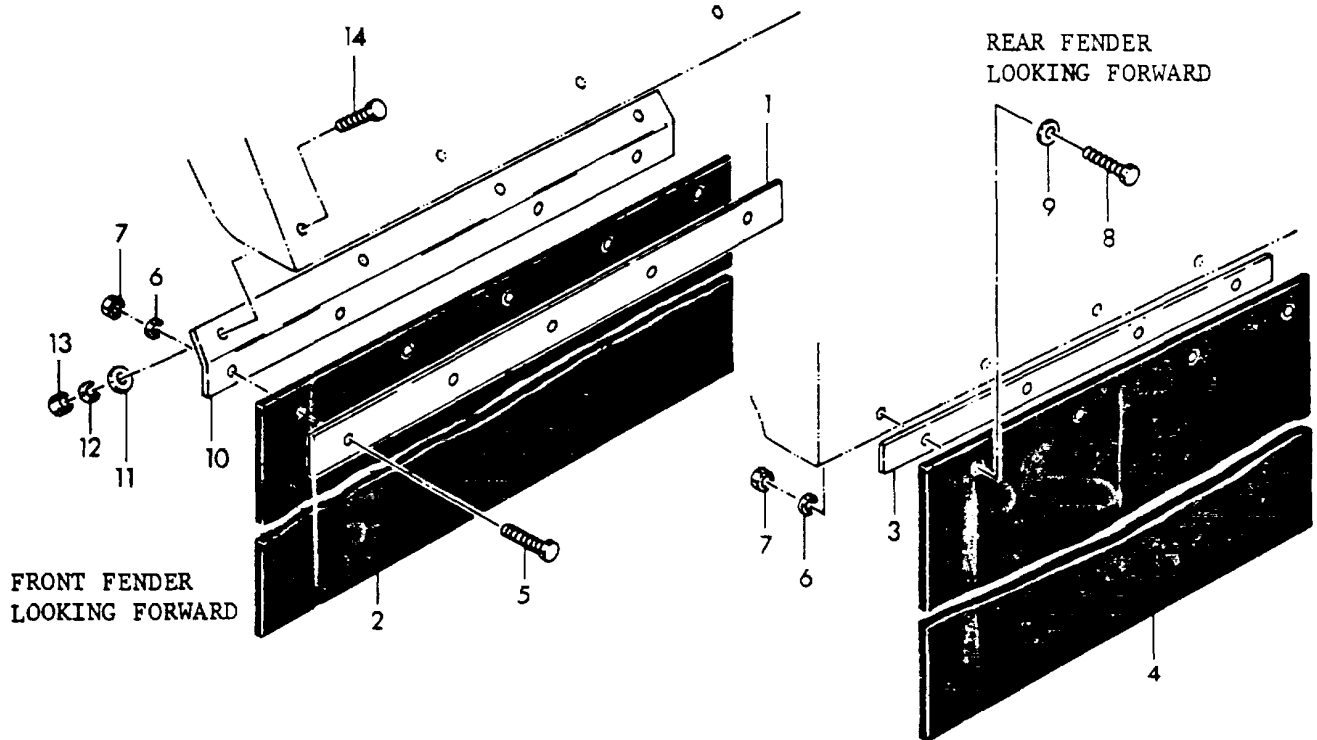

REF. NO.	PART NUMBER	DESCRIPTION	NO. REQ'D
MUD GUARD INSTALLATION			
1	4-147-1-00013	Plate-----	2
2	7-814-000126	Flap, Mud-----	2
3	4-137-1-00860	Retainer, Mud Flap-----	2
4	7-814-000115	Flap, Mud-----	2
5	MS90725-64	Bolt, Hex Head - 3/8"-16 N.C. x 1 1/2" Length - Grade 1 - -----	10
6	MS35338-46	Lockwasher - 3/8" Medium - Spring Steel -----	18
7	MS51967-8	Nut, Hex - 3/8"-16 N.C. - Grade A -----	18
8	MS90725-36	Bolt, Hex Head - 3/8"-16 N.C. x 1 1/4" Length - Grade 1- -----	8
9	MS27183-13	Flatwasher - 3/8" Wide - Steel -----	8
10	6-030-000946	Angle, Mounting-----	2
11	MS27183-13	Flatwasher - 3/8" I.D. x 7/8" O.D. x .083 Thick - Steel -----	8
12	SM35338-45	Lockwasher - 5/16" Medium - Spring Steel -----	8
13	MS51967-5	Nut, Hex - 5/16"-18 N.C. - Grade A-----	8
14	MS90725-36	Bolt, Hex Head - 5/16"-18 N.C. x 1 1/4" Length - Grade 1- -----	8

2-147-1-00011 (C)

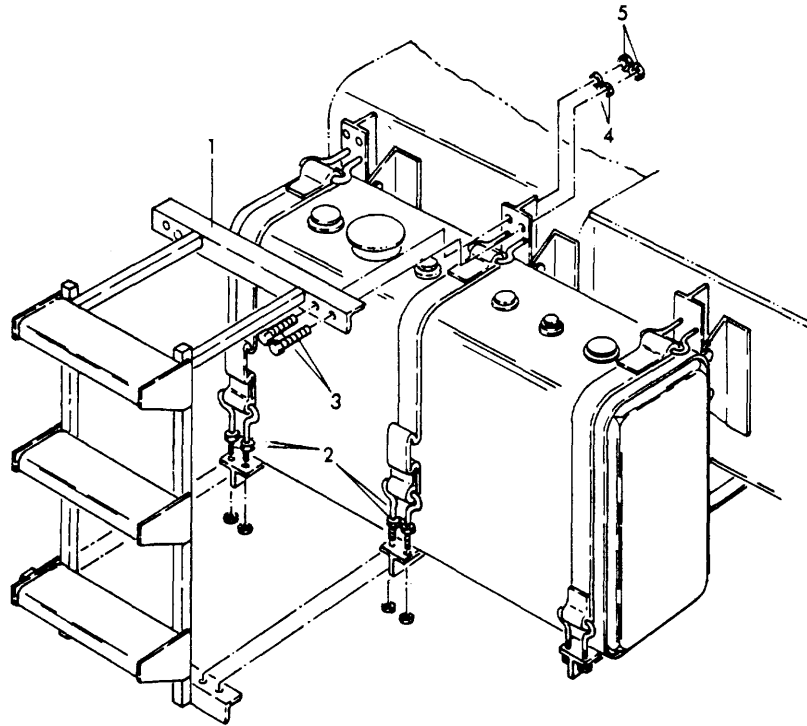

REF. NO.	PART NUMBER	DESCRIPTION	NO. REQ'D
		ACCESS LADDER INSTALLATION	
1	2-137-1-00075	Access Ladder Weldment-----	1
2	MS35691-29	Nut, Hex Jam - 7/16"-20 N.F. - Grade A -----	4
3	MS90725-87	Bolt, Hex Head - 7/16"-14 N.C. x 1 1/4" Length - Grade 1 -----	4
4	MS35338-47	Lockwasher - 7/16" Medium - Spring Steel-----	4
5	MS51967-11	Nut, Hex - 1/16"-14 N.C. - Grade A-----	4

2-137-1-00128

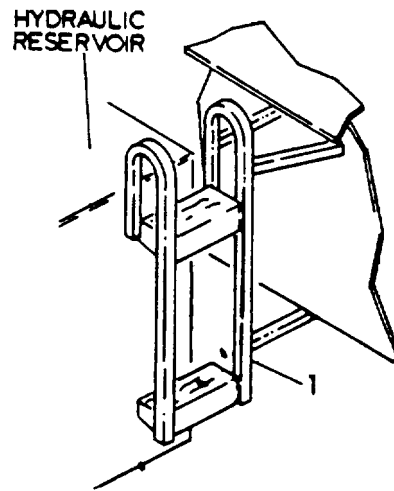

REF. NO.	PART NUMBER	DESCRIPTION	NO. REQ'D
ACCESS LADDER INSTALLATION			
1	6-869-000306	Access Ladder Weldment-----	1
			6-869-000307

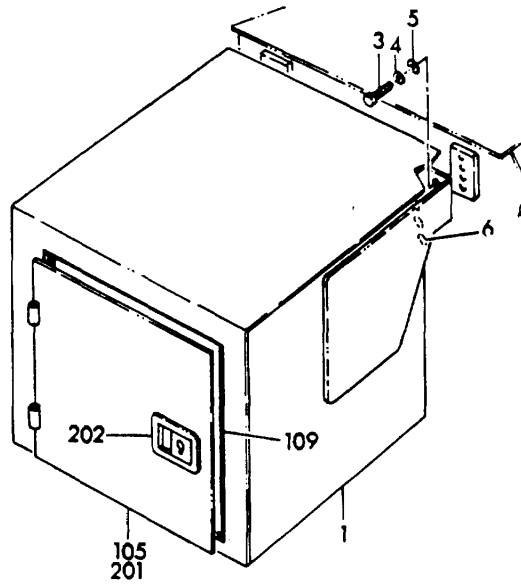

REF. NO.	PART NUMBER	DESCRIPTION	NO. REQ'D
SLING BOX INSTALLATION			
1	2-120-I-00203	Sling Box Weldment - Includes Item 3 105 & 109 -----	1
3	MS90725-59	Bolt, Hex Head 3/8"-16 N.C. x 7/8" Length - Grade 1 -----	8
4	MS35338-46	Lockwasher 3/8" Medium - Spring Steel -----	8
5	MS27183-13	Flatwasher 7/16" I.D. x 1" O.D. x .083 Thick - Steel -----	8
6	7-242-000015	Button, Plug -----	8
105	2-120-1-00071	Door Weldment - Consists of Items Z01 & 202-----	1
109	6-637-000007	Moulding-----	1
201	4-120-1-00204	Door -----	1
202	7-585-000099	Latch, Recessed-----	1

SK 772229

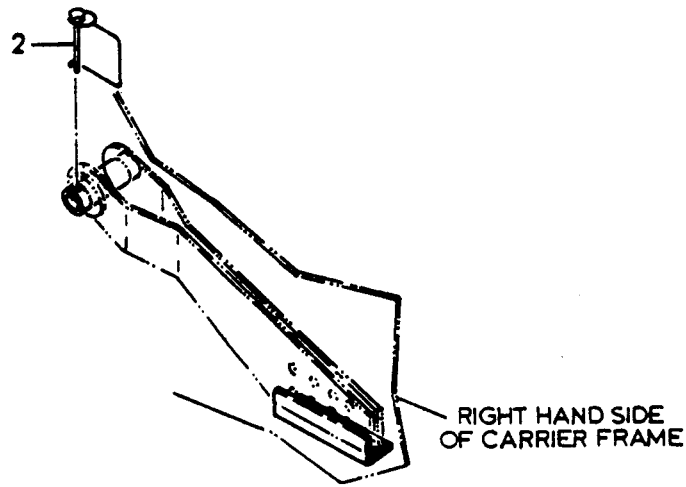

REF. NO.	PART NUMBER	DESCRIPTION	NO. REQ'D
PILE DRIVER SUPPORT PLATE STORAGE INSTALLATION			
2	7-689-000002	Pin, Lock-----	1
			SK 772264 (A)

ADDENDUM B
PARTS CATALOG
(CARRIER) CAB GROUP

B-107/(B-107.1 Blank)



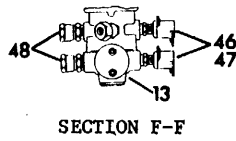
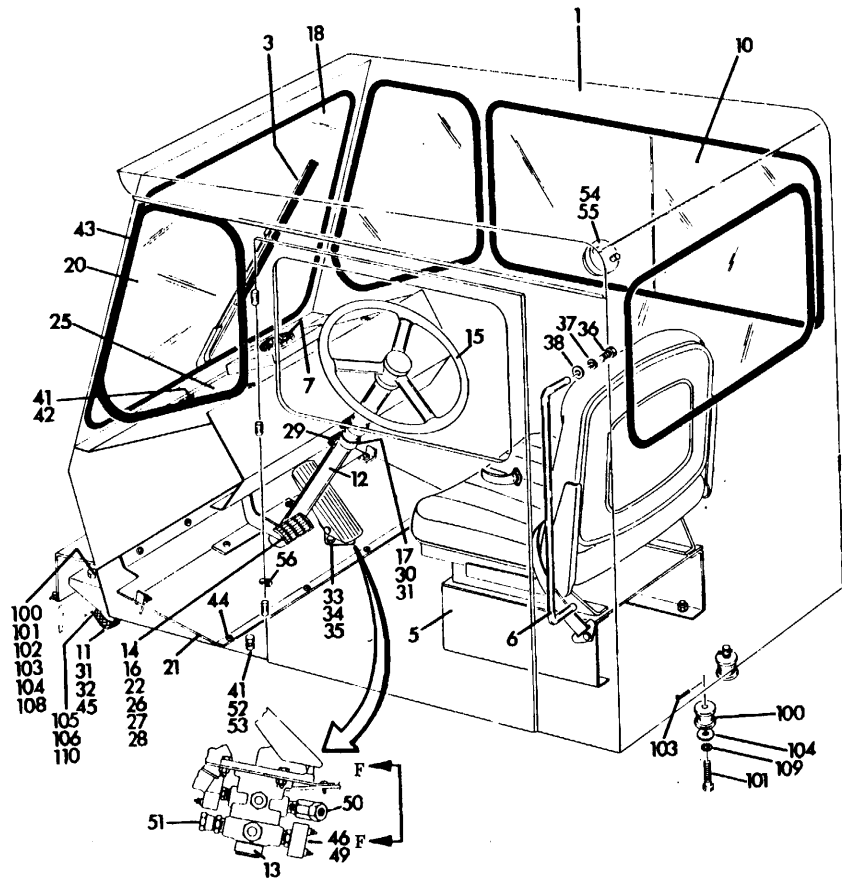

ITEMS NOT SHOWN
2 WIRING HARNESS INSTALLATION

SK 771994

B-107.2

REF. NO.	PART NUMBER	DESCRIPTION	NO. REQ'D
CAB ASSEMBLY & INSTALLATION			
1	SK 771982	Cab Weldment & Assembly-----	1
2		Wiring Harness Installation - See Separate Parts List ----	1
3		Electric Windshield Wiper Installation - See Separate Parts List	1
4		Windshield Washer Installation - See Separate Parts List	1
5		Seat & Seat Belt Installation - See Separate Parts List----	1
6	7-511-000099	Handrail, Grab-----	1
7	7-515-000015	Heater - Defroster -----	1
	7-345-001703	Plug - Shur -----	1
10	7-498-000243	Window Assembly-----	1
11	7-850-000046	Strap, Engine Ground -----	1
12	7-362-000010	Column Assembly -----	1
13	7-926-000644	Valve, Dual Brake -----	1
14	7-671-000009	Pad, Pedal -----	1
15	7-970-000124	Wheel, Steering -----	1
16	7-834-000015	Spring, Governor -----	1
17	7-850-000087	Strap, Steel-----	2
18	7-498-000203	Glass, Windshield -----	1
19	7-498-000216	Glass -----	1
20	7-498-000196	Glass -----	2
21	4-120-4-00098	Board, Toe -----	1
22	2-120-4-00037	Pedal Weldment -----	1
25	4-147-4-00049	Bracket, Fan -----	1
26	6-689-000157	Pin, Clevis -----	1
27	6-200-090506	Bushing -----	1
28	MS24665-457	Pin, Cotter 5/32" x 1 1/4" Lg. - Steel -----	1
29	6-705-006236	Shim -----	A/R
30	MS90725-60	Bolt, Hex Head 3/8"-16 N.C. x 1" Lg. Grd. 1-----	4
31	MS35338-46	Lockwasher 3/8" Medium - Spring Steel -----	5
32	MS27183-14	Flatwasher 13/32" I.D. x 13/16" O.D. x .065 Thick - Steel	2
33	MS90725-34	Bolt, Hex Head 5/16"-18 N.C. x 1" Lg. Grd.1-----	3
34	MS35338-45	Lockwasher 5/16" Medium - Spring Steel -----	3
35	MS51967-5	Nut, Hex 5/16"-18 N.C. - Grade A-----	3
36	MS90725-109	Bolt, Hex Head 1/2"-13 N.C. x 1" Lg. Grd. 1-----	2
37		Lockwasher 1/2" Medium - Spring Steel -----	2
38	MS27183-18	Flatwasher 17/32" I.D. x 1 1/16" O.D. x .095 Thick - Steel	2
41	MS35338-44	Lockwasher 1/4" Medium - Spring Steel -----	10
42	MS35206-277	Screw, Round Head Machine 1/4"-20 N.C. x 3/8" Length - Grade 1-----	4
43	6-637-003041	Weatherstrip -----	1

REF. NO.	PART NUMBER	DESCRIPTION	NO. REQ'D
CAB ASSEMBLY & INSTALLATION			
44	7-791-141250	Screw, Hex Head Acorn Washer Self-Drill 1/4" - 20 x 3/4" Length - Steel-----	7
45	MS35649-2382	Nut, Hex 3/8"-16 N.C. - Grade A -----	1
46	7-444-030256	Bushing -----	4
47	7-486-000266	Low Pressure Indicator -----	2
48	7-446-100635	Connector, Male -----	1
49	7-872-000163	Switch, Stoplight-----	2
50	7-446-080640	Elbow, Male-----	1
51	7-446-080635	Connector, Male -----	1
52	7-872-000112	Switch, Dimmer -----	1
53	MS35206-279	Screw, Round Head Machine 1/4"-20 x 1/2" Length - Grade 1 -----	2
54	6-581-000176	Lamp Assembly -----	1
	7-581-000159	Lamp -----	1
	7-345-001831	Plug, Shur -----	1
	9-581-100033	Bulb -----	1
55	MS35206-261	Screw, Round Head Machine #10-24 x 3/8" Length - Grade 1 -----	1
	7-872-000203	Switch, Door -----	1
100	7-638-000052	Mount, Shock -----	4
101	6-099-000198	Bolt -----	4
102	MS51922-49	Locknut, Hex 5/8"-11 N.C. - Grade A -----	2
103	MS24665-457	Pin, Cotter 5/32" x 1 1/4" Length - Steel-----	4
104	7-950-200171	Flatwasher 11/16" I.D. x 2 3/8" O.D. x .165 Thick - Steel -----	4
		Nut, Hex 3/8"-16 - Grade A -----	1
106	MS35338-46	Lockwasher 3/8" Medium - Spring Steel -----	1
108	MS27183-21	Flatwasher 21/32" I.D. x 1 5/16" O.D. x .095 Thick - Steel -----	2
		Lockwasher 5/8" Medium - Spring Steel -----	2
110	MS27183-14	Flatwasher 13/32" I.D. x 13/16" O.D. x .065 Thick - Steel	2

SK 771994

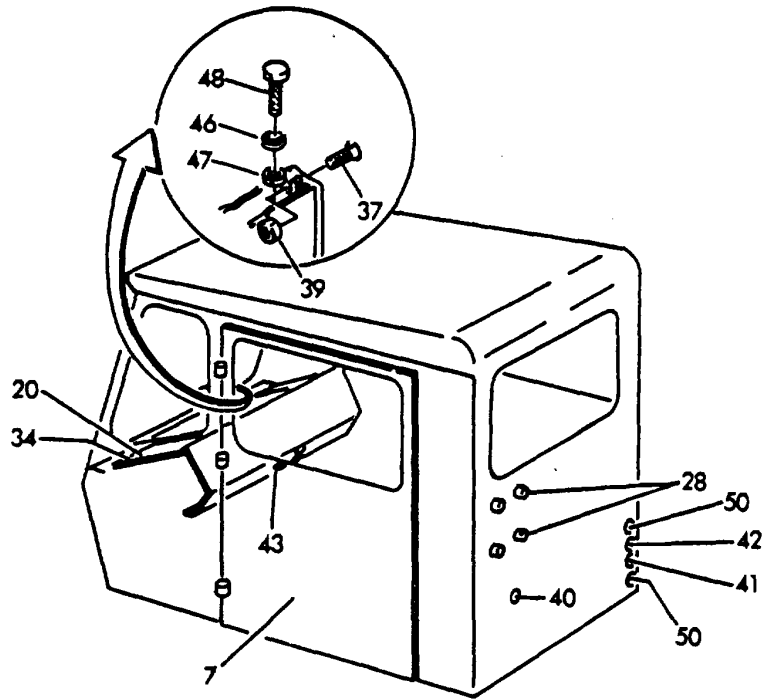

REF. NO.	PART NUMBER	DESCRIPTION	NO. REQ'D
CAB WELDMENT & ASSEMBLY			
7	SK 772257	Door Weldment -----	1
20	4-147-4-00121	Panel, Dash Access -----	2
28	7-659-000142	Insert, Threaded - -----	4
34	MS24629-47	Screw, Pan Head Self-Drill #10-24 x 5/8" Length -----	8
37	MS35190-291	Screw, Flat Head Machine 1/4"-20 x 1" Length - Grade 1 -----	6
39	MS51922-1	Locknut, Hex 1/4"-20 N.C. - Grade A -----	6
40	7-709-000034	Plug, Dot -----	2
41	7-709-000021	Plug, Dot -----	1
42	7-709-000035	Plug, Dot -----	4
43	7-659-000143	Insert, Threaded -----	4
46	MS35338-44	Lockwasher 1/4" Medium - Spring Steel -----	2
47	MS35649-2252	Nut, Hex 1/4"-20 N.C. - Grade A -----	2
48	MS90725-8	Bolt, Hex Head 1/4"-20 N.C. x 1" Length - Grade 1 -----	2
50	7-242-000020	Button, Plug -----	2

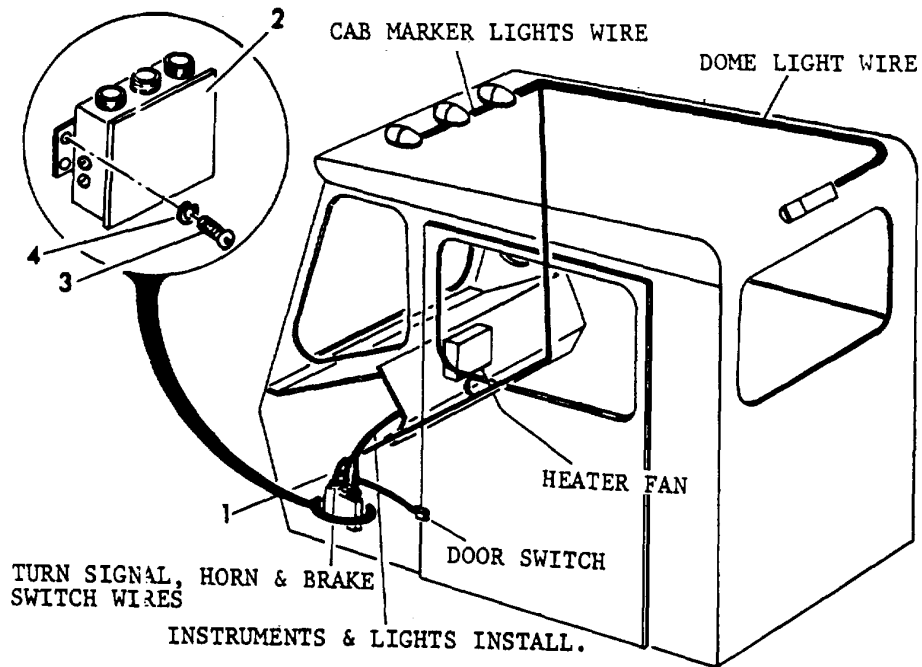

REF. NO.	PART NUMBER	DESCRIPTION	NO. REQ'D
WIRING HARNESS INSTALLATION - CARRIER CAB			
1	SK 772242	Wiring Harness Assembly (Cab Interior)-----	1
2	2-120-1-00142	Junction Box Assembly -----	1
3	MS35206-279	Screw, Machine 1/4"-20 N.C. x 1/2" Length - Grade 1 -----	4
4	MS35338-44	Lockwasher 1/4" Medium - Spring Steel -----	4

SK 772243

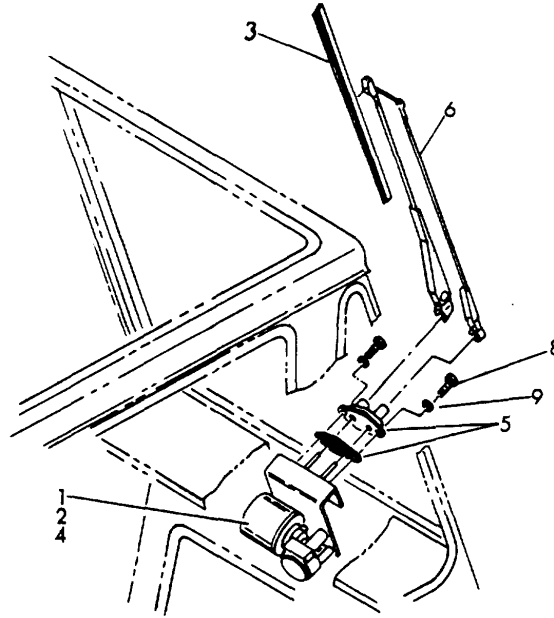

REF. NO.	PART NUMBER	DESCRIPTION	NO. REQ'D
-------------	-------------	-------------	--------------

ELECTRIC WINDSHIELD WIPER INSTALLATION

1	7-576-000066	Kit, Motor -----	1
2	7-033-000081	Arm, Crank -----	1
3	6-083-000009	Blade, Wiper -----	1
4	7-810-000866	Shaft, Pivot-----	1
5	7-576-000017	Kit, Adapter -----	1
6	7-033-000041	20" Pantograph Arm Assembly -----	1
8	MS90726-6	Bolt, Hex Head 1/4"-28 N.F. x 3/4" Lg. - Grade 1-----	2
9	MS35338-44	Lockwasher 1/4" Medium Spring Steel-----	2

2-137-4-00009(D)

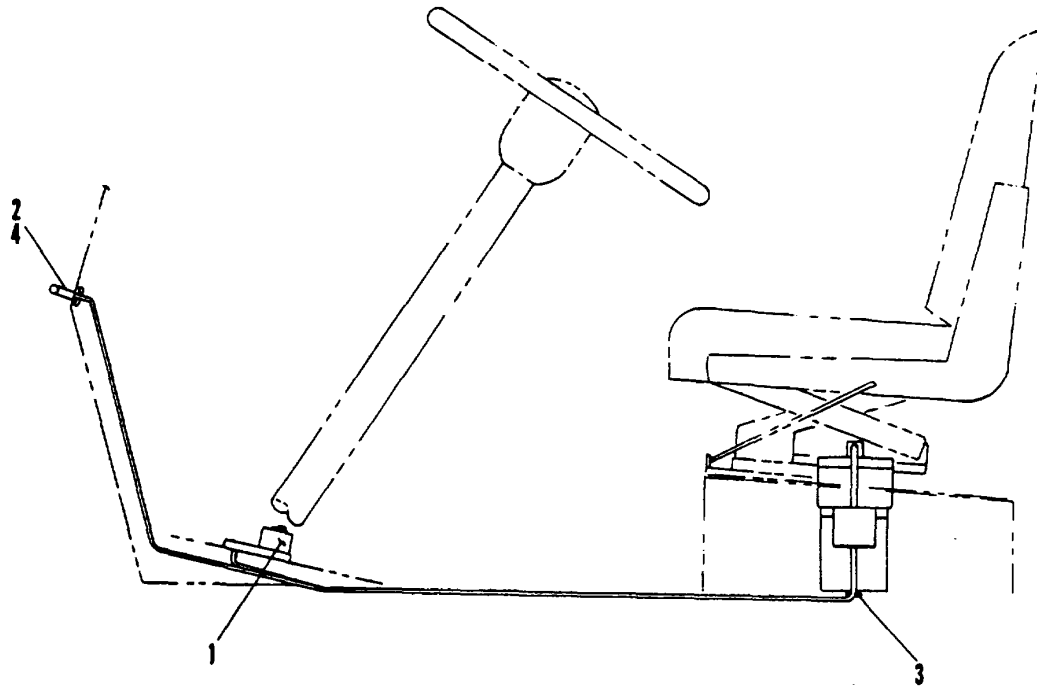

REF. NO.	PART NUMBER	DESCRIPTION	NO. REQ'D
----------	-------------	-------------	-----------

WINDSHIELD WASHER INSTALLATION

*1	7-949-000184	Washer, Windshield-----	1
2	6-200-040408	Bushing, Plain -----	2
3	7-506-000020	Grommet, Rubber (Split)-----	1
4	7-531-000046	Jet Holder-----	2

*Mounting Hardware Includes With This Assembly.

6-033-000153 (A)

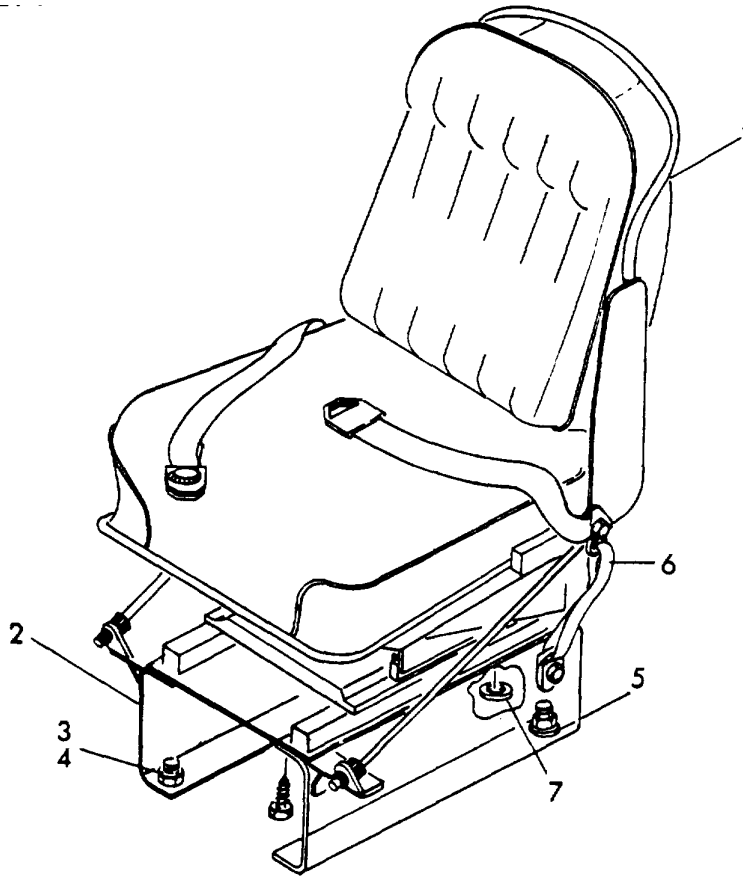

REF. NO.	PART NUMBER	DESCRIPTION	NO. REQ'D
----------	-------------	-------------	-----------

SEAT & SEAT BELT INSTALLATION

1	7-798-000022	Driver's Seat Assembly -----	1
2	2-197-4-00025	Seat Support Weldment -----	1
3	MS51967-8	Nut, Hex 3/8"-16 N.C. - Grade A -----	6
4	MS35338-46	Lockwasher 3/8" Medium Spring Steel-----	6
5	MS27183-14	Flatwasher 7/16" I.D. x 1" O.D. x .083 Thick Steel -----	2
6	7-576-000069	Kit, Seat Belt-----	1
7	MS27183-13	Flatwasher 3/8" I.D. x 7/8" O.D. x .083 Thick Steel-----	2

6-798-000024(B)

REF. NO.	PART NUMBER	DESCRIPTION	NO. REQ'D
	7-326-000015	Steering Column (Consists of all items except #9 & #18)	
1	9-326-100013	Jacket Tube Service Assembly-----	1
2	9-326-100017	Housing (Flasher & Light) -----	1
3	9-326-100006	Seat, Spring-----	2
4	9-326-100018	Bearing Assembly -----	1
6	9-326-100015	Contact Brush Assembly-----	1
7	9-326-100014	Switch Assembly-----	1
9	7-025-000051	Horn Button Assembly-----	1
10	9-326-100020	Tubing, Protective-----	1
11	9-326-100021	Screw #10-16 x 5/16" -----	2
12	9-326-100022	Screw #4 -24 x 3/8" -----	2
13	9-326-100023	Housing, Pilot Light-----	1
14	9-326-100024	Socket Assembly-----	1
15	7-581-000052	Bulb-----	1
16	9-326-100026	Cover-----	1
17	9-326-100027	Screw #6-32 x 1/4" -----	2
18	7-593-000134	Lever, Signal-----	1
19	9-326-100028	Screw 1/4"-28 x 1" -----	2
20	9-326-100029	Nut 1/4"-28-----	2
21	9-326-100030	Washer 5/16" x 3/4"-----	2
22	9-326-100005	Spacer -----	1
23	9-326-100004	Nut 13/16"-20 -----	1
24	9-326-100035	Coupling, Flexible -----	1
	9-326-100011	Shell Assembly -----	1
25	9-326-100010	Cup, Dust-----	1
26	9-326-100008	Spring-----	1
27	9-270-100813	Bearing -----	1
28	9-326-100007	Wheel Tube Assembly -----	1
29	9-326-100009	Washer 1 1/64" x 1 3/8"-----	1
30	9-326-100002	Ring, Reinforcing -----	1
31	9-326-100033	Label, Hazard Switch -----	1
32	9-326-100034	"O"Ring -----	1

7-326-000010 (A)

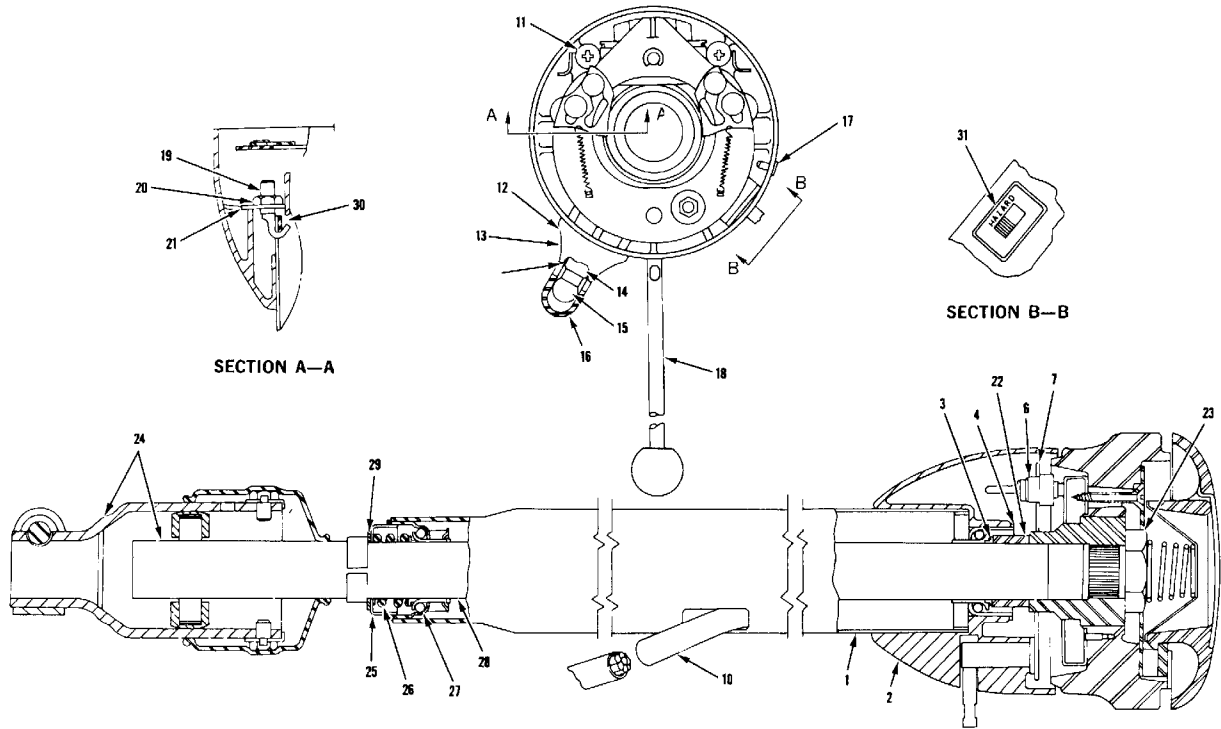

7-326-000010

B-116

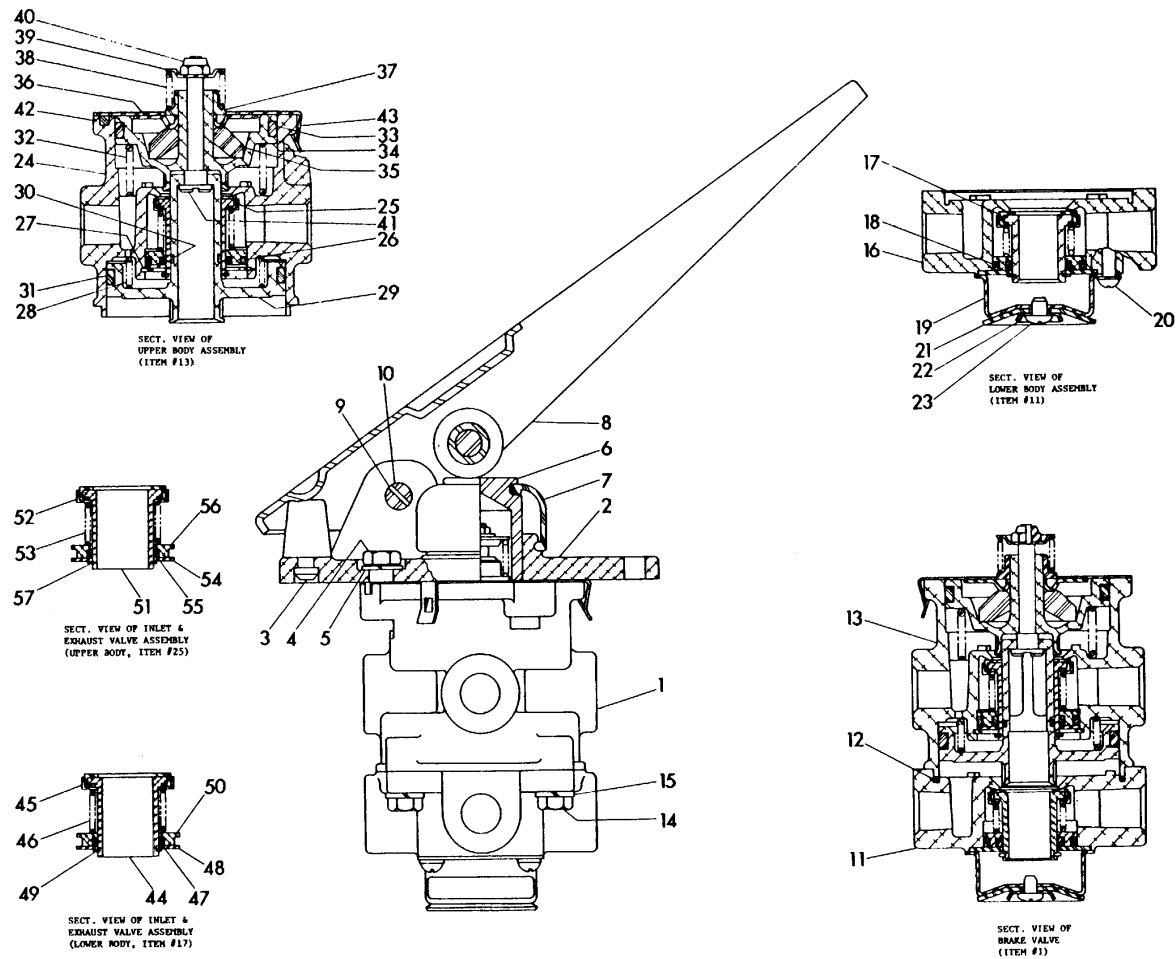

B-117

7-926-000644

REF. NO.	PART NUMBER	DESCRIPTION	NO. REQ'D
DUAL BRAKE VALVE ASSEMBLY			
	7-926-000644	Dual Brake Valve Ass'y.-----	
1	9-926-101987	Valve, Dual Brake ----- (Includes Items #11 Thru #15)	1
2	9-926-101528	Plate, Mounting-----	1
3	9-926-101531	Button, Stop -----	1
4	9-926-101519	Screw, Hex 5/16"-18-----	3
5	9-926-101472	Lockwasher -----	3
6	9-926-101527	Plunger -----	1
7	9-802-100126	Boot -----	1
8	9-926-101522	Treadle Assembly-----	1
9	9-926-101521	Pin-----	1
10	9-926-101520	Pin, Roll -----	1
11	9-926-101988	Lower Body Assembly ----- (Includes Items #16 Thru #23)	1
12	9-926-101990	"O" Ring -----	1
13	9-926-101989	Upper Body Assembly ----- (Includes Items #24 Thru #43)	1
14	9-926-101390	Capscrew, 1/4"-20-----	4
15	9-332-100036	Lockwasher 1/4"-----	4
16	9-926-101991	Body, Lower -----	1
17	9-926-101992	Inlet & Exhaust Valve Assembly ----- (Includes Items #44 Thru #50)	1
18	9-926-101726	"O" Ring -----	1
19	9-926-101666	Cover, Exhaust- -----	1
20	9-926-101644	Machine Screw W/Lockwasher -----	4
21	9-926-101667	Diaphragm-----	1
22	9-926-101668	Washer, Diaphragm -----	1
23	9-926-101669	Screw, Forming #10-24-----	1
24	9-926-101993	Body, Upper -----	1
25	9-926-101784	Inlet & Exhaust Valve Assembly ----- (Includes Items #51 Thru #57)	1
26	9-926-101640	"O" Ring -----	1
27	9-332-100113	Ring, Retaining- -----	1
28	9-926-101994	Spring, Relay Piston -----	1
29	9-926-101736	Piston, Relay -----	1
30	9-926-101273	"O" Ring- -----	1
31	9-926-101737	"O" Ring -----	1
32	9-926-101739	Spring, Piston Return -----	1
33	9-926-101261	"O" Ring- -----	1
34	9-926-101995	Piston, Primary- -----	1
35	9-926-101267	Spring, Rubber -----	1
6	9-926-101741	Seat, Spring-----	1
37	9-926-101745	Nut, Spring Seat-----	1
38	9-926-101743	Spring, Stem-----	1
39	9-926-101744	Guide, Spring -----	1
40	9-926-101742	Nut, Esna -----	1
41	9-926-101738	Stem -----	1
42	9-926-101996	Filter, Vent-----	1
43	9-926-101262	Retainer -----	1

REF. NO.	PART NUMBER	DESCRIPTION	NO. REQ'D
DUAL BRAKE VALVE ASSEMBLY			
44	9-926-101728	Inlet & Exhaust Valve-----	1
45	9-926-101729	Retainer, Valve-----	1
46	9-926-101730	Spring-----	1
47	9-926-101496	"O" Ring -----	1
48	9-926-101997	Washer, Special -----	1
49	9-926-101733	Ring, Retaining -----	1
50	9-926-101732	Retainer, "O" Ring-----	1
51	9-926-101746	Inlet & Exhaust Valve-----	1
52	9-926-101747	Retainer, Valve-----	1
53	9-926-101748	Spring, Upper Valve-----	1
54	9-926-101749	Washer, Special -----	1
55	9-926-101750	"O" Ring, Upper Valve -----	1
56	9-926-101751	Retainer, "O" Ring-----	1
57	9-926-101752	Ring, Retaining -----	1

Sheet 2 of 2

7-926-000644

B-119

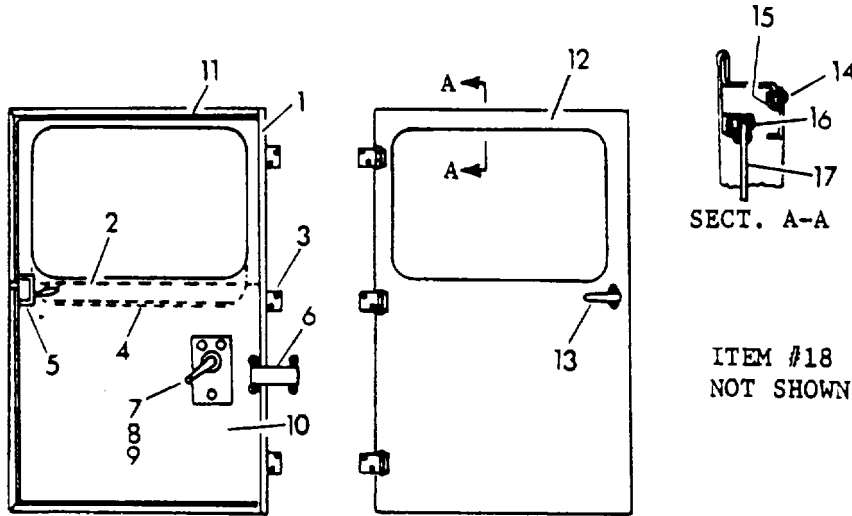

REF. NO.	PART NUMBER	DESCRIPTION	NO. REQ'D
----------	-------------	-------------	-----------

DOOR ASSEMBLY

	SKD772257	Door Assembly	
1	9-392-100004	Rubber, Hinge Seal-----	1
2	9-392-100006	Weatherstrip -----	1
3	9-392-100021	Hinge, Door (With Grease Fitting)-----	3
4	9-392-100005	Channel, Bottom -----	1
5	9-392-100013	Lock, Safety Door-----	1
6	9-392-100009	Strap, Door Check -----	1
7	9-392-100014	Regulator, Handle-----	1
8	9-392-100015	Escutcheon, Adjusting-----	1
9	9-392-100022	Regulator, Window -----	1
10	9-392-100023	Inner, Panel Assembly -----	1
11	9-392-100010	Sealer, Door-----	1
12	9-392-100024	Outer Panel Assembly-----	1
13	SK 772262	Handle, Outer-----	1
14	9-392-100042	Screw, Phillips Head -----	30
15	9-392-100019	Tinnerman-----	1
16	9-392-100011	Channel, Glass Run-----	1
17	9-392-100012	Glass, Door -----	1
18	9-392-100025	Plate, Striker (Not Shown) -----	1

SKD772257

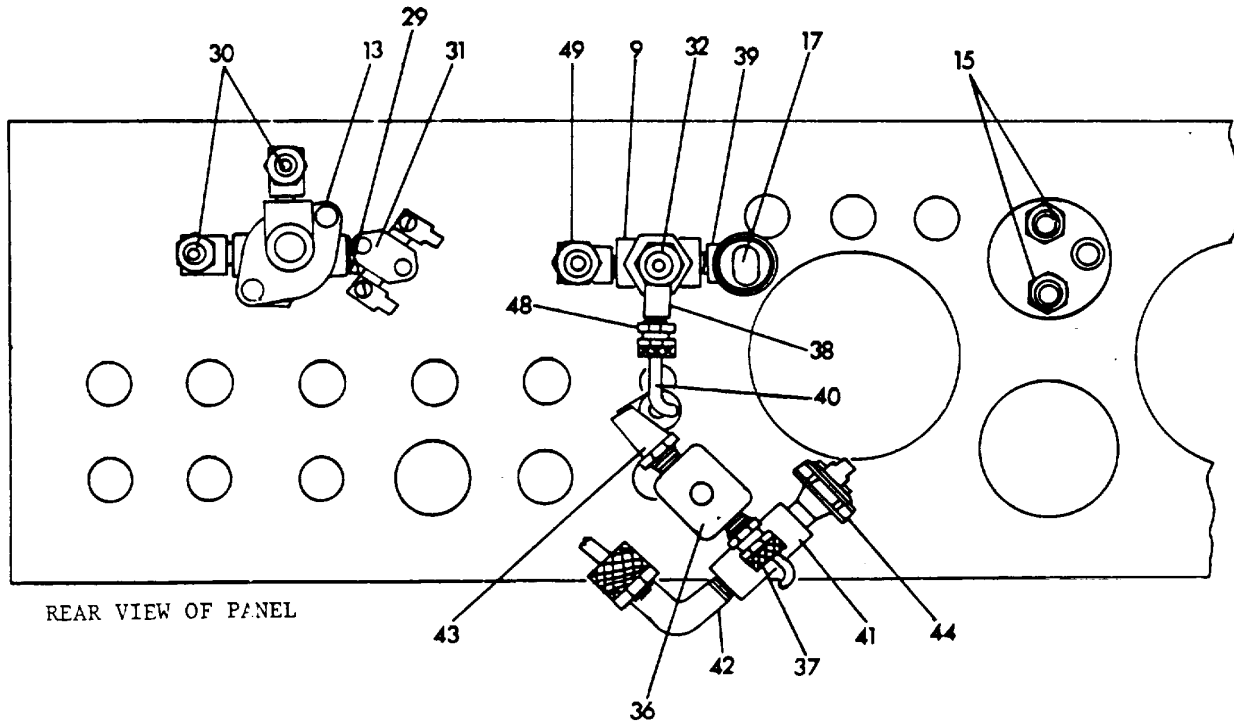
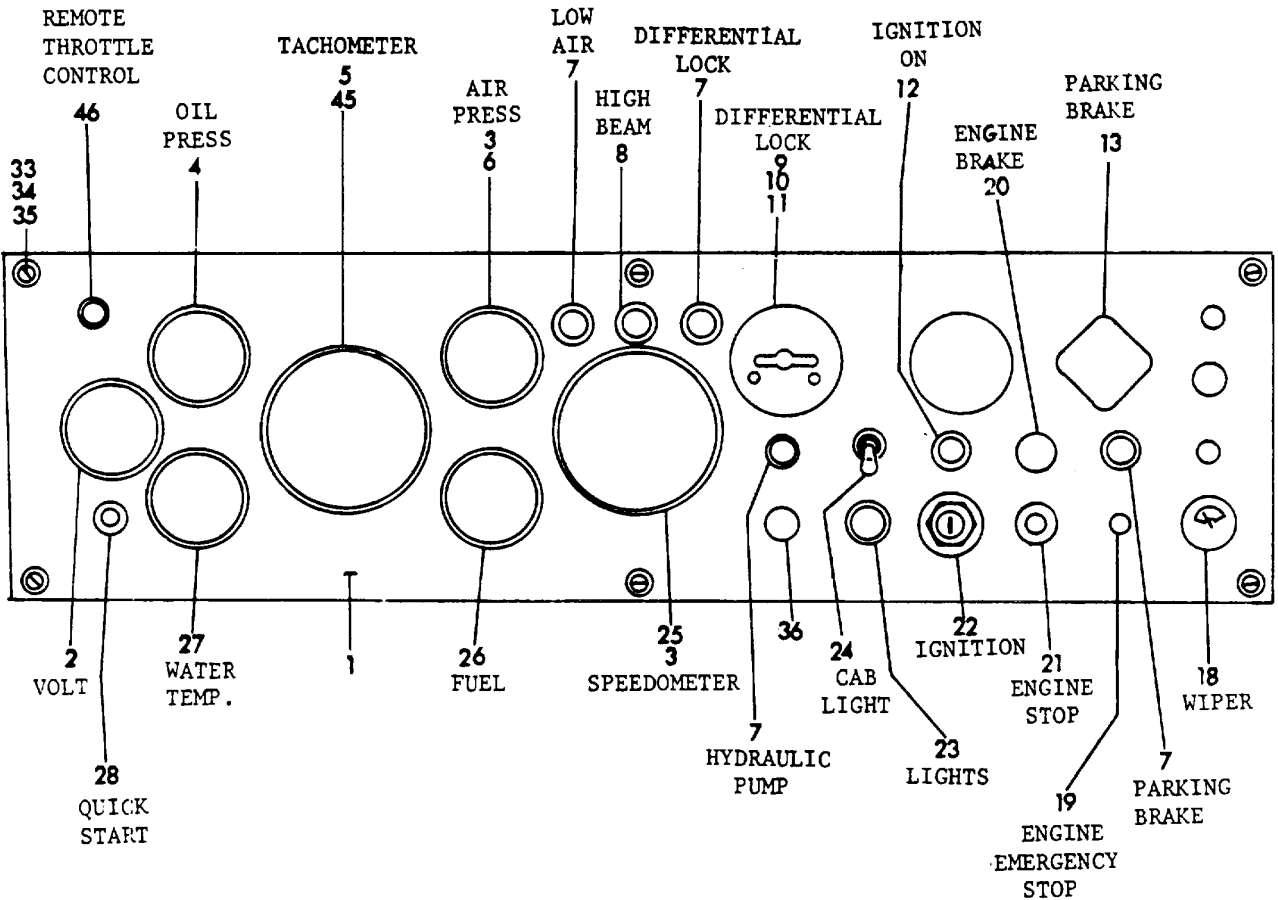

SK772270

REF. NO.	PART NUMBER	DESCRIPTION	NO. REQ'D
INSTRUMENTS & LIGHTS INSTALLATION			
1	SKU 772252	Carrier Panel Assembly-----	1
2	7-486-000495	Voltmeter -----	1
	7-581-000052	Bulb -----	1
3	7-576-000085	Kit, 12 Volt Lighting -----	2
	7-581-000052	Bulb -----	2
4	7-486-000494	Gauge, Oil Pressure -----	1
	7-581-000052	Bulb -----	1
5	7-486-000638	Tachometer -----	1
	7-581-000052	Bulb -----	1
6	7-486-000507	Gauge - Dial Air Pressure -----	1
7	7-581-000116	Red Indicator Light Assembly -----	4
	7-581-000166	Indicator Light W/Red Lens 1	Per Ass'y.
	7-581-000165	Bulb, 12 Volt 1	Per Ass'y.
8	7-581-000114	Blue Indicator Light Assembly -----	1
	7-581-000167	Indicator Light W/Blue Lens 1	Per Ass'y.
	7-581-000165	Bulb, 12 Volt 1	Per Ass'y.
9	7-926-000460	Valve, Axle Lockout Control -----	1
10	7-486-000257	Dial-----	1
11	MS35206-261	Screw, Round Head Machine ,10-24 N.C. x 3/8" Length - Grade 1 -----	2
12	7-581-000115	Green Indicator Light Assembly -----	1
	7-581-000168	Indicator Light W/Green Lens 1	Per Ass'y.
	7-581-000165	Bulb, 12 Volt - 1	Per Ass'y.
13	7-926-000199	Valve, Push Pull Control -----	1
15	7-445-020402	Adapter, Swivel -----	2
16	7-978-000480	Harness Assembly - Not Shown -----	1
17	7-872-000048	Switch -----	1
18	7-872-000158	Switch, Two Speed -----	1
20	7-242-000012	Button, Plug -----	1
21	7-872-000021	Switch, Push Button Starter -----	1
22	SK 772263	Switch, Ignition & Start -----	1
23	7-872-000134	Switch, Headlamp-----	1
24	7-872-000062	Switch, Toggle -----	1
25	7-486-000479	Speedometer - -----	1
26	7-486-000497	Gauge, Fuel Level -----	1
	7-581-000052	Bulb-----	1
27	7-486-000496	Gauge, Water Temperature -----	1
	7-581-000052	Bulb -----	1
28	7-872-000021	Switch, Push Button Starter -----	1
29	7-406-000243	Elbow -----	1
30	7-445-020404	Adapter, Swivel-----	2
31	7-486-000266	Indicator, Low Pressure -----	1
32	7-445-020401	Adapter, Swivel -----	1
33	7-429-000011	Fastener, Well-Nut-----	6
34	7-949-000191	Washer, Finishing -----	6
35	7-099-000154	Screw, Cabinet -----	6
36	7-242-000012	Button, Plug -----	1
38	7-888-000098	Tee -----	1

REF. NO.	PART NUMBER	DESCRIPTION	NO. REQ'D
INSTRUMENTS & LIGHTS INSTALLATION			
39	7-445-020404	Adapter, Swivel -----	1
45	7-486-000684	Cartridge, Tachometer Ratio -----	1
46	7-926-000805	Valve, Control -----	1
47	7-406-()00287	Elbow -----	2
48	7-364-000641	Connector -----	1
49	7-445-020404	Adapter, Swivel -----	1
50		Hourmeter Wiring Diagram - Carrier - See Separate Drawing - Not Shown -----	1

Sheet 2 of 2

SK 772270

B-123

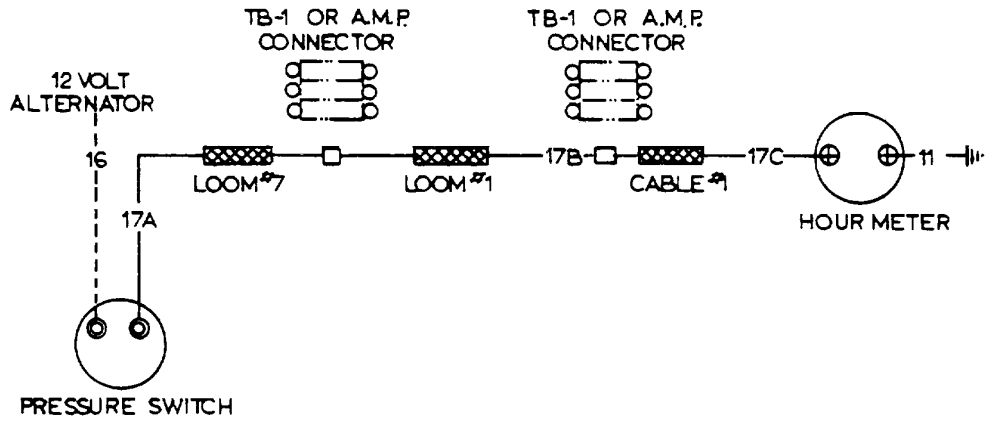

WIRE NO	COLOR	GAUGE
11	BLACK	14
17	GRAY	14
16	RED	14

TERMINAL		
SYM.	TERMINAL	STUD SIZE
	STUD	#4
	STUD	#6
	STUD	#8
	STUD	#10
	STUD	1/4"
	STUD	5/16"
	STUD	3/8"
	STUD	7/16"
	STUD	1/2"
	PIGTAIL	
	FASTON	3/16"
	FASTON	1/4"
	FASTON	5/16"
	DOUBLE BLADE FASTON TAB	1/4"
	SHUR PLUG	
	SPLICE	
	KNIFE DISCONNECT	

SK 771995

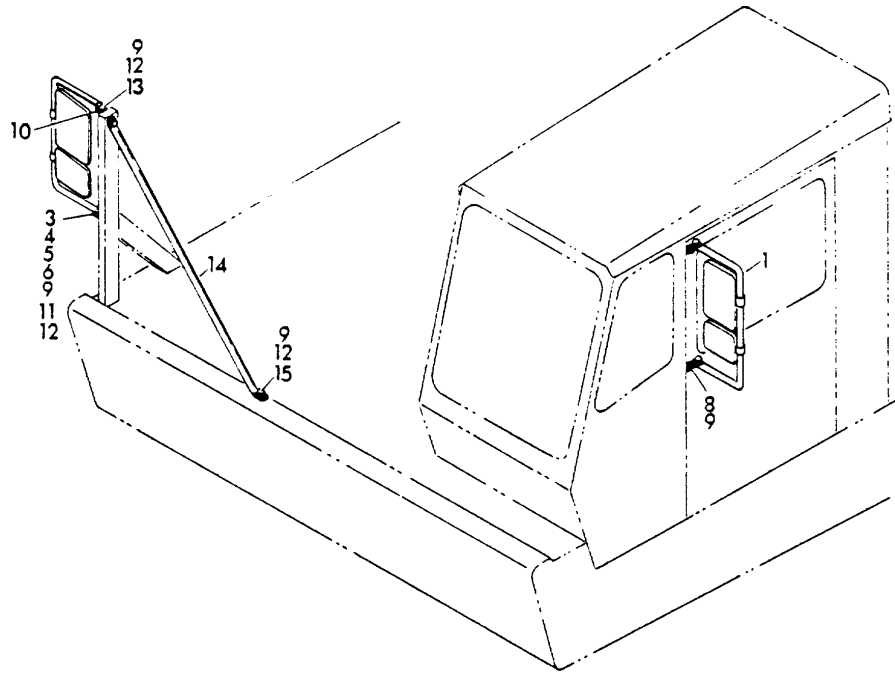

REF. NO.	PART NUMBER	DESCRIPTION	NO. REQ'D
NO. REAR VIEW MIRROR INSTALLATION REQ'D			
1	SKA772415	Mirror Head & Loop Assembly -----	1
3	MS90725-34	Bolt, Hex Head 5/16"-18 N.C. x 1"-Grade 1- -----	2
4	MS35338-45	Lockwasher 5/16" Medium - Spring Steel -----	2
5	MS27183-11	Flatwasher 5/16" Wide Steel -----	2
6	MS51967-5	Nut, Hex 5/16" N.C. - Grade A -----	2
8	MS90725-3	Bolt, Hex Head 1/4"-20 N.C. x 1/2"-Grade 1-----	5
9	MS35338-44	Lockwasher 1/4" Medium - Spring Steel -----	9
10	7-184-000463	Bracket, Mounting -----	4
11	MS90725-13	Bolt, Hex Head 1/4"-20 N.C. x 1 3/4" Lg. - Grade 1 -----	3
12	MS51967-2	Nut, Hex 1/4"-20 N.C. - Grade A -----	4
13	MS90725-14	Bolt, Hex Head 1/4"-20 N.C. x 2" Length - Grade 1 -----	1
14	4-194-1-00106	Brace -----	1
15	MS51851-88	Screw, Self-Tapping 1/4"-20 N.C. x 1" Lg.- -----	1

SK 772410

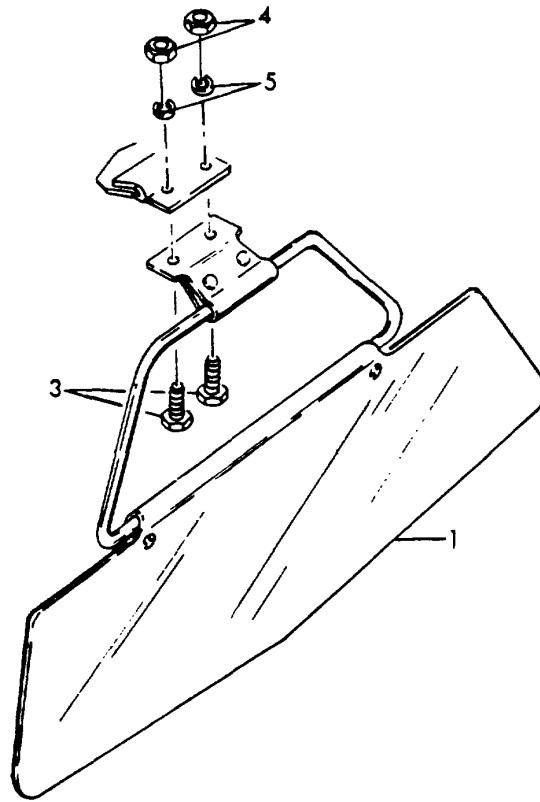

REF. NO.	PART NUMBER	DESCRIPTION	NO. REQ'D
SUN VISOR INSTALLATION			
1	7-942-000002	Visor, Sun -----	1
3	MS35206-263	Screw, Round Head Machine #10-24 N.C. x -1/2" Length - Grade 1 -----	2
4	MS35649-202	Nut, Hex #10-24 N.C. - Grade A -----	2
5	MS35338-43	Lockwasher #10 Medium - Spring Steel -----	2

SK 771944

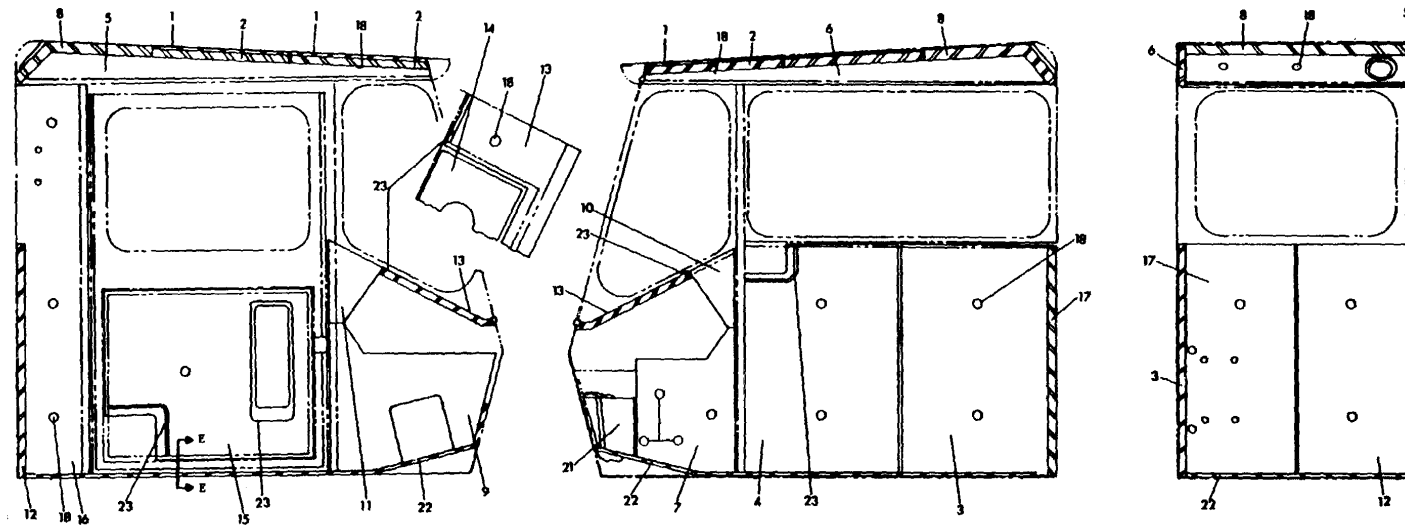

6-001-000345

6-001-000345

B-127

REF. NO.	PART NUMBER	DESCRIPTION	NO. REQ'D
ACOUSTICS INSTALLATION - CARRIER CAB			
1	7-001-000221	Foam, Acoustical -----	2
2	7-001-000222	Foam, Acoustical -----	2
3	7-001-000013	Foam - R.H. Side -----	1
4	7-001-000184	Foam - R.H. Side -----	1
5	7-001-000340	Foam - L.H. Side -----	1
6	7-001-000339	Foam - R.H. Side -----	1
7	7-001-000341	Foam - R.H. Side -----	1
8	7-001-000342	Foam - Top -----	1
9	7-001-000343	Foam - L.H. Side -----	1
10	7-001-000008	Foam -----	1
11	7-001-000009	Foam -----	1
12	7-001-000010	Foam - L.H. Back -----	1
13	7-001-000014	Foam - Dash -----	1
14	7-001-000015	Foam - Fan -----	1
15	7-001-000016	Foam - Door -----	1
16	7-001-000287	Foam - L.H. Side Rear -----	1
17	7-001-000018	Foam - R.H. Back -----	1
18	7-659-000093	Nut -----	25
19	6-814-000168	Guard, Edge -----	1
20	MS24625-43	Screw, Pan Head Self-Tapping #10 x 1/2" Lg. -----	5
21	7-001-000299	Foam -----	1
22	7-001-000344	Mat, Floor -----	1
23	6-637-007007	Molding, Pinch Top -----	1

6-001-000345(B)

**ADDENDUM B
PARTS CATALOG
(CARRIE R)**

ENGINE GROUP

B-129

PARTS LIST IN-LITNE 71 ENGINE
 CONTRACT DSA700-77-C-8511
 GROVE MODEL THS300-5
 HYDLRAULIC TRUCK CRAVE

1067-7040 (RC)

GROUP NAME	GROUP NO.	TYPE
Cylinder Block	1.1000	4
Air Box Drains	1.1000A	1
Cylinder Head.....	1.2000	17
Engine Lifter Bracket	1.2000A	1
Crankshaft.....	1.3000	4
Crankshaft Front Cover	1.3000A	10
Vibration Damper	1.3000B	63
Crankshaft Pulley	1.3000C	334
Crankshaft Pulley Belt	1.3000D	237
Flywheel.....	1.4000A	682
Flywheel Housing (SAE #2)	1.5000A	486
Connecting Rod and Piston	1.6000	139
Camshaft and Gear Train	1.7000	19
Balance Weight Cover.....	1.7000A	9
Valve Operating Mechanism.....	1.8000	21
Rocker Cover	1.8000A	324
Fuel Injector C65.....	2.1000A	115
Fuel Pump.....	2.2000	125
Fuel Pump Drain	2.2000A	2
Fuel Filter	2.3000A	351
Fuel Manifold Connections	2.4000	52
Fuel Lines	2.5000A	131
Governor. Mechanical.....	2.7000A	144
Injector Controls.....	2.9000	22
Throttle Controls.....	2.9000A	789
Air Inlet Housing.....	3.3000A	131
Blower.....	3.4000	14
Blower Drive Shaft.....	3.4000A	3
Oil Pump.....	4.1000A	104
Oil Distribution System.....	4.1000B	8
Oil Pressure Regulator	4.1000C	23
Oil Filter	4.2000A	83
Oil Cooler	4.4000A	52
Oil Filter	4.5000A	125
Dipstick	4.6000A	731
Oil Pan.....	4.7000A	1
Ventilating System.....	4.8000A	631
Fresh Water Pump.....	5.1000	7
Fresh Water Pump Cover	5.1000A	16
Water Outlet Manifold.....	5.2000A	162
Thermostat.....	5.2000B	174
Water By-Pass Tube	5.2000C	15
Water Connections.....	5.3000B	12
Fan	5.4000A	1080
Exhaust Manifold.....	6.1000A	306
Exhaust Muffler	6.2000A	233
Battery Charging Generator.....	7.1000A	1983
Starting Motor	7.3000A	252
Tachometer Drive.....	7.0000B	269
Engine Mounting	11.1000A	3
Air Compressor	12.4000A	937
Hydraulic Pump.....	12.5000A	228

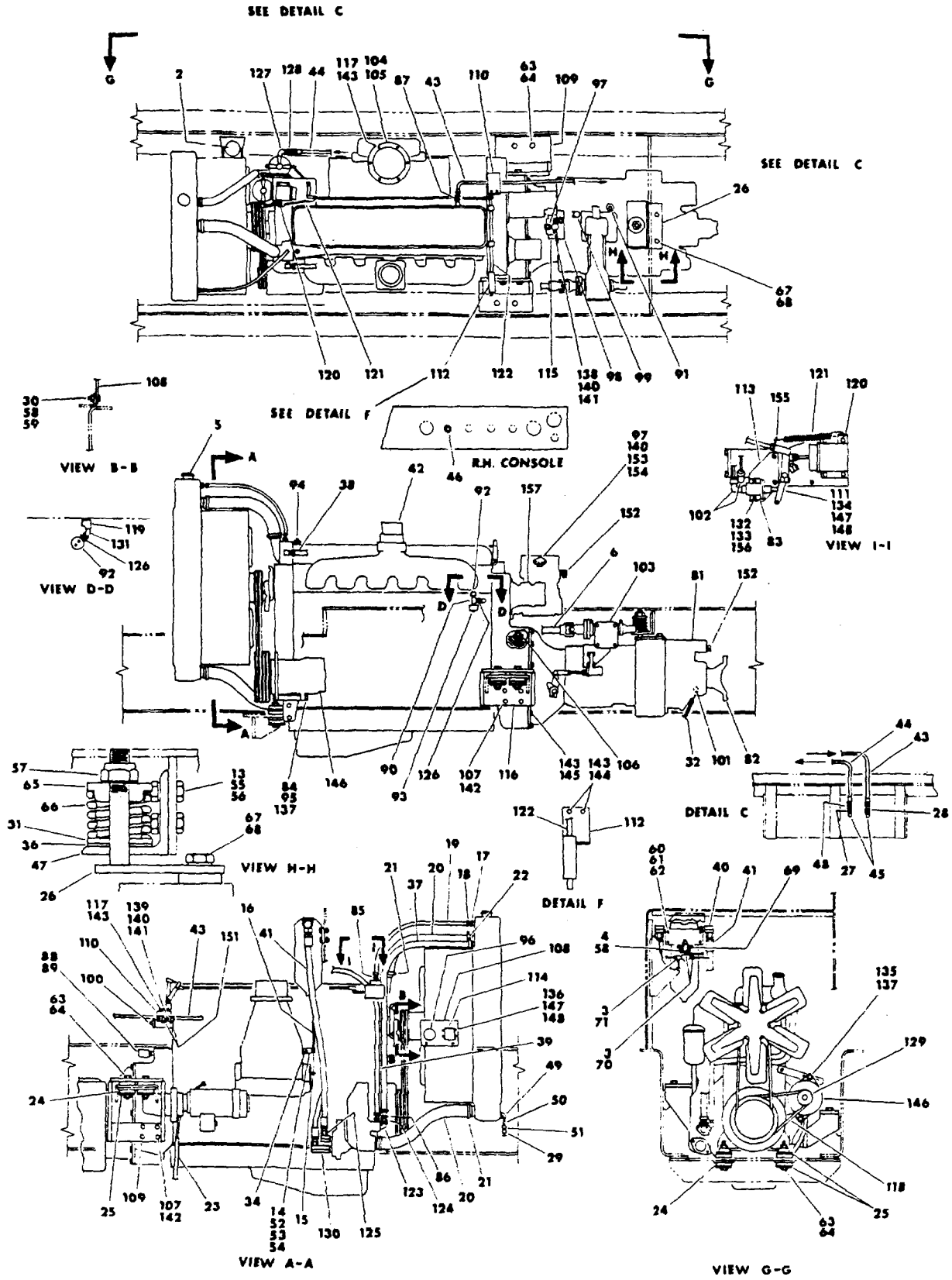

2-130-8-00057

B-129.2

REF. NO.	PART NUMBER	DESCRIPTION	NO. REQ'D
ENGINE AND TRANSMISSION ASSEMBLY AND INSTALLATION G.M.C. 6-71N & FELLER RTO-613T			
2		Quick Start Installation - See Separate	
		Parts List -----	1
3	7-444-020156	Reducer -----	3
4	MS90725-6	Bolt, Hex Head 1/4"-20 N.C. x 3/4" Length- Grade 1 -----	2
5		Radiator & Oil Cooler Installation - See Separate Parts List-----	1
6		Transmission Shift Installation - See Separate Parts List-----	1
7		Battery Installation - Not Shown - See Separate Parts List-----	1
9		Throttle Installation (G.M.C. 6-71N) - Not Shown - See Separate Parts List-----	1
13	MS90725-113	Bolt, Hex Head 1/2"-13 N.C. x 1 1/2" Length - Grade 5 -----	4
14	7-300-000056	Clamp -----	1
15	7-846-000033	Stop, Throttle - -----	1
16	7-246-000131	Cable Assembly - 17' - -----	1
17	7-649-000004	Nipple, Hose - -----	1
18	7-300-000040	Clamp, Hose -----	2
19	7-543-000073	Hose, Radiator -----	1
20	7-543-000369	Hose, Radiator -----	2
21	7-300-000035	Clamp, Hose -----	4
22	7-300-000020	Clamp, Hose -----	2
23	6-543-000420	Hose, Radiator -----	1
24	7-638-000025	Mounting, Center Bonded -----	12
25	7-949-000148	Washer, Dock -----	8
26	2-130-8-00044	Mounting Stud Weldment -----	1
27	7-926-000311	Valve, Check -----	1
28	7-445-080601	Adapter, Swivel -----	1
29	7-926-000014	Valve, Pet Drain Cock - -----	1
30		Nut, Hex 1/4"-20 N.C. - Grade A -----	2
31	6-949-000227	Washer, Steel -----	1
32	7-246-000347	Cable, Flexible Drive -----	1
33		Wiring Diagram - Not Shown - See Separate Parts List -----	1
34	4-137-8-00033	Bracket, Cable -----	1
36	6-949-000226	Washer, Rubber -----	1
37	6-543-000362	Hose, Radiator -----	1
38	6-543-000365	Hose, Heater - -----	1
39	6-543-000364	Hose, Heater - -----	1
40	7-445-161204	Adapter, Swivel -----	2
41	7-542-504807	Hose -----	2
42	2-137-8-00161	Flange Adapter Weldment -----	1
43	7-542-221211	Hose, Fuel -----	1
44	7-542-424015	Hose, Fuel - -----	1
45	7-444-040470	Elbow, Street -----	2
46	7-872-000021	Switch, Push Button Start -----	1

REF. NO.	PART NUMBER	DESCRIPTION	NO. REQ'D
ENGINE AND TRANSMISSION ASSEMBLY AND INSTALLATION G.M.C. 6-71N & FULLER RTO-613T			
47	4-130-8-00035	Support -----	1
48	7-445-080802	Adapter, Swivel -----	1
49	7-444-020270	Elbow, Street -----	1
50	6-650-020160	Nipple -----	1
51	7-444-000244	Coupling, Pipe -----	1
52	MS35206-265	Screw, Round Head Machine #10-24 N.C. x 3/4" Length - Grade 1 -----	1
53	fIS35649-202	Nut, Rex #10-24 N.C. - Grade A -----	1
54	MS35335-32	Lockwasher #10 Toothlock - Spring Steel -----	1
55	7-660-180008	Nut, hex -----	4
56	MS35338-48	Lockwasher 1/2" Medium - Spring Steel -----	4
57	MS35691-65	Locknut, Hex 7/8"-9 N.C. - Grade A -----	1
58	MS35338-44	Lockwasher 1/4" Medium - Spring Steel -----	4
59	MS90725-3	Bolt, Hex Head 1/4"-20 N.C. x 1/2" Length- Grade 1 -----	2
60	MS90725-58	Bolt, Hex Head 3/8"-16 N.C. x 3/4" Length- Grade 1 -----	4
61	MS35338-46	Lockwasher 3/8" Medium - Spring Steel -----	4
62	MS35649-2382	Nut, Hex 3/8"-16 N.C. - Grade A -----	4
63	MS51922-53	Locknut, Hex 5/8"-18 N.F. - Grade A -----	6
64	MS90726-174	Bolt, Hex Head 5/8"-18 N.F. x 4 1/2" Length - Grade 5 -----	6
65	6-834-000096	Retainer, Spring -----	1
66	7-834-000097	Spring -----	1
67	6-099-000173	Bolt, Safety Wire -----	2
68	6-978-000259	Wire, Safety -----	1
69	7-926-000806	Valve, Relay -----	1
70	7-406-000287	Elbow -----	2
71	7-888-000099	Tee -----	1
(A)			
81	6-904-000076	Fuller Transmission RTO-613T - -----	1
82	7-308-000084	Yoke, End -----	1
83	7-300-000203	Clamp, Air - -----	1
84		Locknut, Hex 1/2"-13 N.C. - Grade A -----	1
85	7-649-000004	Nipple, Hose - -----	1
86	7-649-000030	Nipple, Hose - -----	1
87	7-445-040601	Adapter, Swivel -----	1
88	7-486-000670	Sender, Tachometer - -----	1
89	7-486-000123	Tip, Drive - -----	1
90	7-888-000018	Tee -----	1
91	7-872-000115	Switch, Neutral Safety -----	1
92	7-872-000107	Switch, Pressure -----	1
93	7-352-000054	Sender, Pressure - Dual Gauges - -----	1
94	7-352-000053	Sender, Temperature - Dual Gauges -----	1

REF. NO.	PART NUMBER	DESCRIPTION	NO. REQ'D
ENGINE AND TRANSMISSION ASSEMBLY AND INSTALLATION G.M.C. 6-71N & FULLER RTO-613T			
95	7-115-185250	Bolt, Hex Head 1/2"-13 N.C. x 6 1/2" Length - Grade 5 -----	1
96	7-486-000499	Hourmeter -----	1
97	7-445-080804	Adapter, Swivel -----	2
98	7-926-000542	Valve, Flow Control -----	1
99	7-872-000114	Switch, Back-up Lamp -----	1
100	7-502-000003	Governor, D-2 Air -----	1
101	7-013-000176	Adapter, Speedometer - -----	1
102	7-406-000287	Elbow -----	2
103	7-352-000027	Control, Fuller SRC-10 Slave Unit -----	1
104	7-013-000165	Adapter, Air Inlet -----	1
105	7-794-000246	Gasket -----	1
106		Clutch & Slave Cylinder Installation - See Separate Parts List-----	1
107	MS90725-113	Bolt, Hex Head 1/2"-13 N.C. x 1 1/2" Length - Grade 5 -----	8
108	6-705-006588	Bracket, Mounting -----	1
109	2-137-8-00112	Engine Mounting Weldment - R.H. -----	1
110	6-184-000085	Bracket, Mounting -----	1
111	6-593-000184	Control Lever Weldment -----	1
112	2-130-8-00030	Mounting Bracket Weldment -----	1
113	6-705-006854	Plate, Mounting -----	1
114	7-750-000005	Solenoid -----	1
115	2-137-8-00104	Mounting Bracket Weldment -----	1
116	2-137-8-00116	Engine Mounting Weldment - L.H. -----	1
117	MS90725-60	Bolt, Hex Head 3/8"-16 N.C. x 1" Length - Grade 1 -----	8
118	7-074-000066	Belts, Matched Set - -----	1
119	7-888-000085	Tee, Street -----	1
120	6-030-000847	Angle -----	1
121	7-834-000015	Spring, Governor - -----	1
122	6-768-000945	Rod -----	1
123	7-444-040470	Elbow, Street -----	1
124	7-445-120817	Reducer -----	1
125	7-445-121204	Adapter, Swivel -----	1
126	7-445-020249	Nipple, Pipe - -----	1
127	7-444-030370	Elbow, Street -----	1
128	7-445-060801	Adapter, Swivel -----	1
129	7-718-000216	Pulley, Alternator - -----	1
130	7-445-121205	Adapter, Swivel -----	1
131	7-444-010190	Elbow, Street -----	1
132	MS35649-202	Nut, Hex #10-24 N.C. - Grade A -----	2
133	MS35338-43	Lockwasher #10 Medium - Spring Steel - -----	2
134	MS90725-6	Bolt, Hex Head 1/4"-20 N.C. x 3/4" Length- Grade 1 -----	1
135	MS90725-111	Bolt, Hex Head 1/2"-13 N.C. x 1 1/4" Length - Grade 5 -----	1

REF. NO.	PART NUMBER	DESCRIPTION	NO. REQ'D
ENGINE AND TRANSMISSION ASSEMBLY AND INSTALLATION G.M.C. 6-71N & FULLER RTO-613T			
136	MS90725-3	Bolt, Hex Head 1/4"-20 N.C. x 1/2" Length- Grade 1 -----	2
137	7-949-000235	Washer, Hardened Round -----	3
138	MS90725-38	Bolt, Hex Head 5/16"-18 N.C. x 1 1/2" Length - Grade 1 - 2	
139	MS90725-44	Bolt, Hex Head 5/16"-18 N.C. x 3" Length - Grade 1 -----	2
140	MS35338-45	Lockwasher 5/16" Medium - Spring Steel - -----	6
141	MS51967-5	Nut, Hex 5/16"-18 N.C. - Grade A -----	4
142	MS35338-48	Lockwasher 1/2" Medium - Spring Steel -----	8
143	MS35338-46	Lockwasher 3/8" Medium - Spring Steel-----	22
144	MS90725-58	Bolt, Hex Head 3/8"-16 N.C. x 3/4" Length- Grade 1 -----	2
145	MS90725-62	Bolt, Hex Head 3/8"-16 N.C. x 1 1/4" Length - Grade 5 -----	12
146	7-029-000009	Alternator - -----	1
147	MS35338-44	Lockwasher 1/4" Medium - Spring Steel -----	3
148	MS51967-2	Nut, Hex 1/4"-20 N.C. - Grade A -----	3
150		Engine Harness Installation - G.M.C. 6-71N - Not Shown - See Separate Parts List -----	1
151	7-445-020404	Adapter, Swivel -----	2
152	7-445-040404	Adapter, Swivel -----	2
153	7-450-000049	Fitting, Discharge - -----	1
154	MS90725-34	Bolt, Hex Head 5/16"-18 N.C. x 1" Length - Grade 1 -----	2
155	4-120-8-00166	Plate -----	1
156	MS35206-265	Screw, Round Head Machine #10-24 N.C. x 3/4" Length - Grade 1 -----	2
157	9-722-100667	Pump, Steer - -----	1

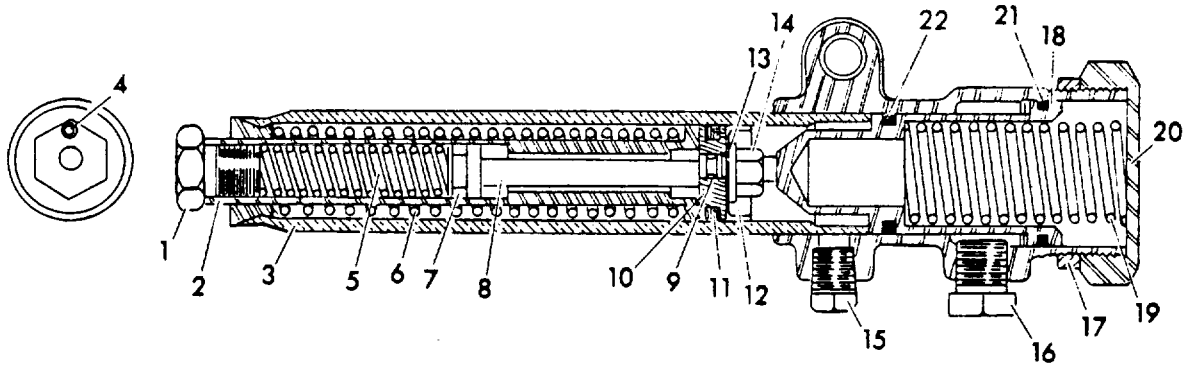

REF. NO.	PART NUMBER	DESCRIPTION	NO. REQ'D
	7-372-000303	Throttle Cylinder W/Floating Piston & Fast Idler	
1	9-372-100311	Adapter, Push Tube-----	1
2	9-372-100312	Tube, Push -----	1
3	9-372-100313	Cylinder, Bushing - -----	1
4	9-372-100314	Setscrew-----	1
5	9-372-100315	Spring, Take-Up-----	1
6	9-372-100316	Spring, Graduating -----	1
7	9-372-100317	Oiler, Felt -----	1
8	9-372-100318	Rod, Piston-----	1
9	9-372-100319	Grommet-----	1
10	9-372-100320	Piston, Throttle -----	1
11	9-372-100321	Oiler, Felt -----	1
12	9-372-100322	Cup, Piston Packing- -----	1
13	9-372-100323	Follower- -----	1
14	9-372-100324	Nut, Hex -----	1
15	9-372-100325	Valve Port, Throttle Plug- -----	1
16	9-372-100326	Plug, Fast Idle Port-----	1
17	9-372-100327	Nut-----	1
18	9-372-100328	Piston-----	1
19	9-372-100329	Spring-----	1
20	9-372-100330	Cap, Cylinder -----	1
21	9-372-100331	Grommet -----	1
22	9-372-100332	Grommet-----	1

7-372-000303

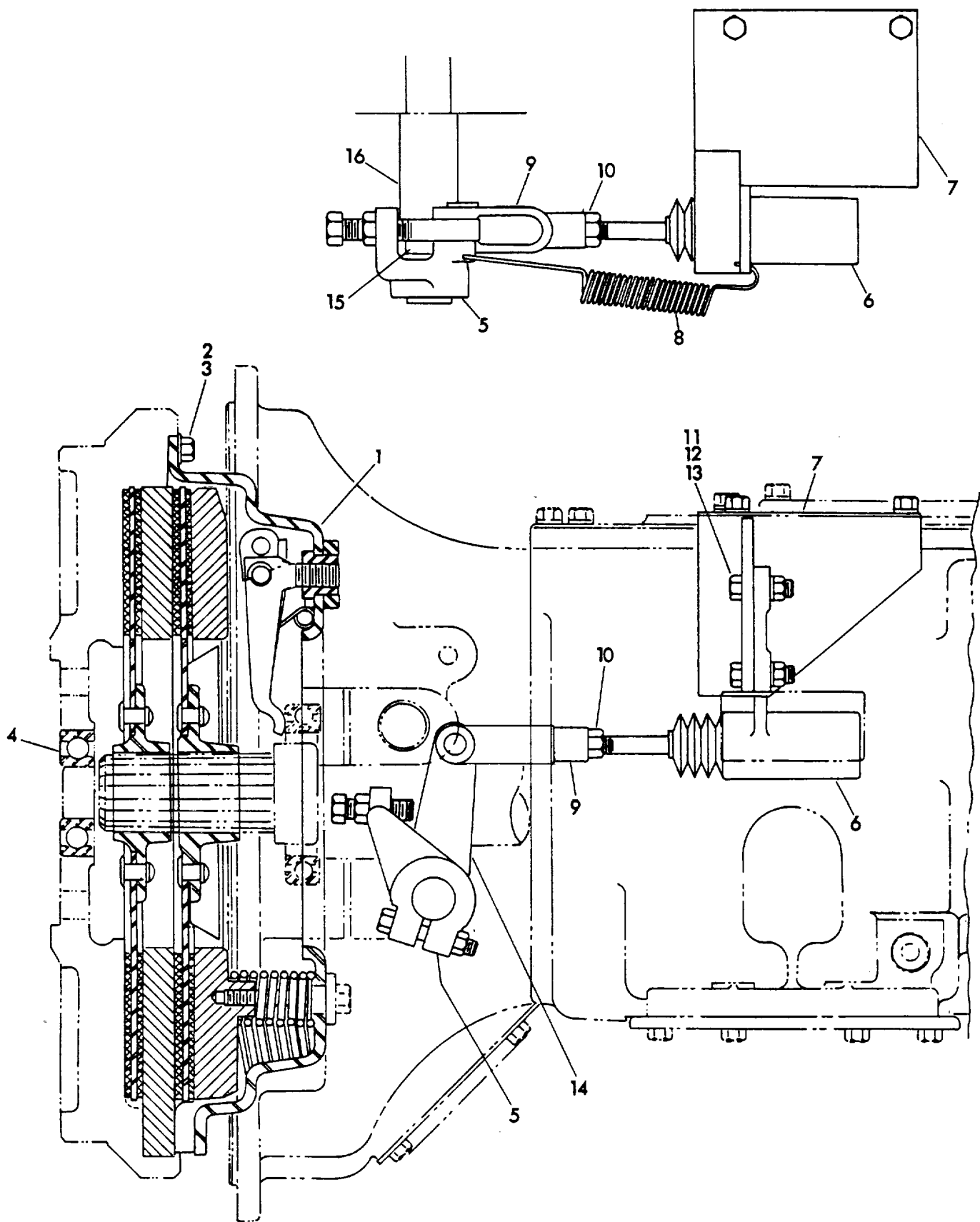

REF. NO.	PART NUMBER	DESCRIPTION	NO. REQ'D
CLUTCH & SLAVE CYLINDER INSTALLATION (G.M.C. ENGINES)			
1	7-316-000007	Clutch-----	1
2	MS35338-46	Lockwasher, 3/8" Medium Spring Steel-----	12
3	MS90725-58	Bolt, Hex Hd., 3/8"-16 N.C. x 3/4" Grade 5 -----	12
4	Not Required		
5	7-593-000095	Lever, Adjusting-----	1
6	6-372-000742	Cylinder, Slave Rework -----	1
7	6-184-000642	Mtg. Bracket Weld-----	1
8	7-834-000020	Spring, Starter Lever Return-----	1
9	7-308-000047	Yoke, 3/8 x 1/2- -----	1
10	MS51968-8	Nut, Hex, 3/8"-24 N.F. Grade A-----	1
11	MS90725-89	Bolt, Hex Hd., 7/16"-14 N.C. x 1 1/2" Lg.- Grade 1 -----	2
12	MS51967-11	Nut, Hex, 7/16"-14 N.C. Grade A-----	2
13	MS35338-47	Lockwasher, 7/16" Medium Spring Steel- -----	2
14	6-033-000156	Crank- -----	1
15	6-205-120802	Bushing-----	1
16	6-205-120810	Bushing-----	1

6-372-001167

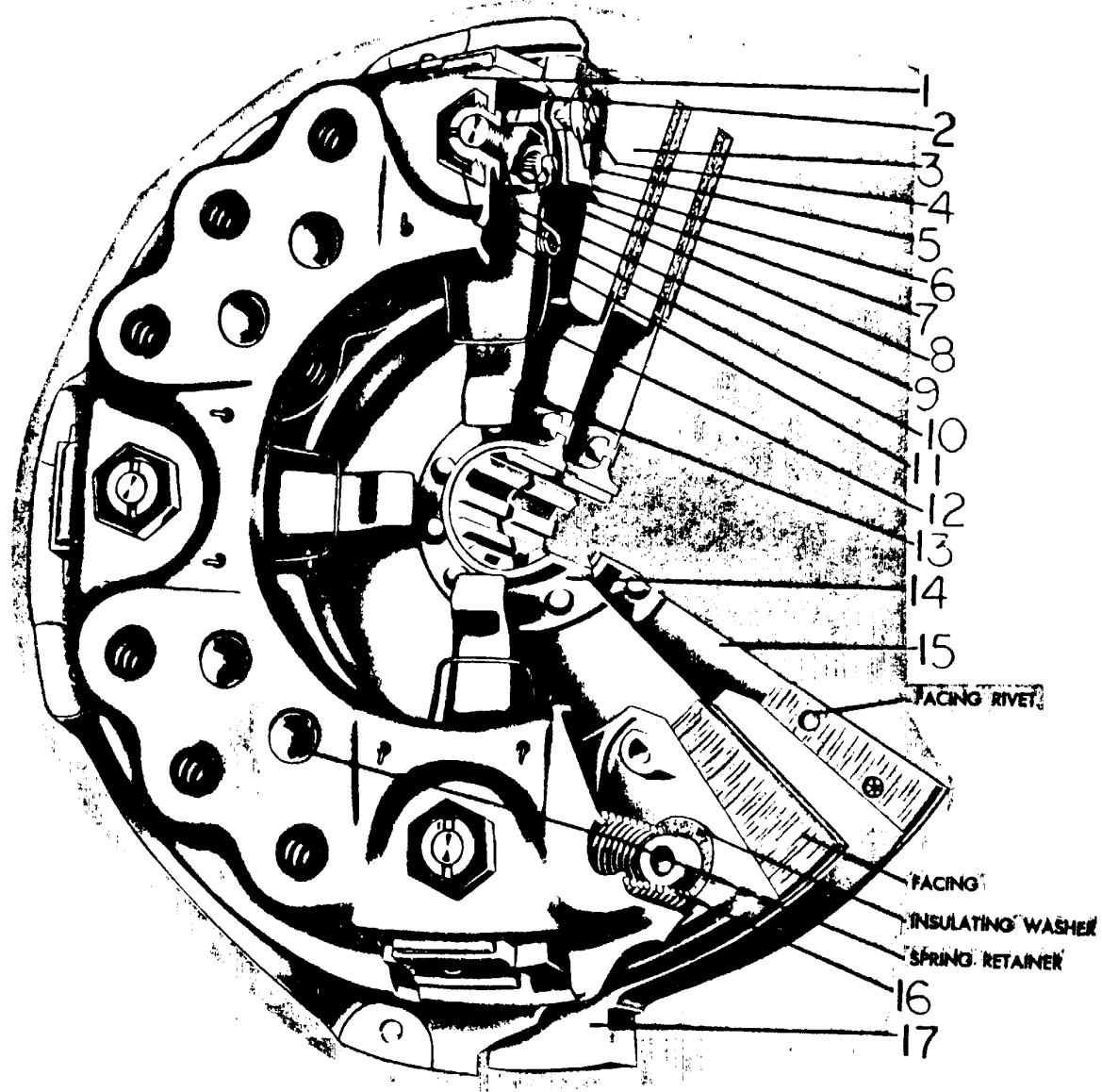

7-316-000007

B-138

REF. NO.	PART NUMBER	DESCRIPTION	NO. REQ'D
		CLUTCH ASSEMBLY	
	7-316-000007	Clutch Assembly	
1	9-316-1-00033	Cover, Flywheel Ring -----	1
2	9-316-1-00034	Pin, Pressure Plate - -----	3
3	9-316-1-00035	Pressure Plate Assembly -----	1
4	9-316-1-00036	Ring, Retaining -----	3
5	9-316-1-00037	Washer - -----	6
6	9-316-1-00038	Bearing, Needle -----	6
	(This part included with Item #3 - But may be purchased separately.)		
7	9-316-1-00039	Pin, Eyebolt - -----	3
8	9-316-1-00040	Bearing, Needle -----	3
	(This part included with Item #9 - But may be purchased separately.)		
9	9-316-1-00041	Eyebolt Assembly -----	3
10	9-316-1-00042	Nut, Adjusting -----	3
11	9-316-1-00043	Nut, Lock -----	3
12	9-316-1-00044	Spring, Retractor -----	3
13	9-316-1-00045	Lever, Release - -----	3
14	9-316-1-00046	Disc Assembly - Pressure Plate Side -----	1
15	9-316-1-00047	Disc Assembly - Flywheel Side -----	1
16	9-316-1-00048	Spring, Pressure - -----	21
17	9-316-1-00049	Plate, Intermediate -----	1
	9-316-1-00050	Kit, Facing	

7-316-000007

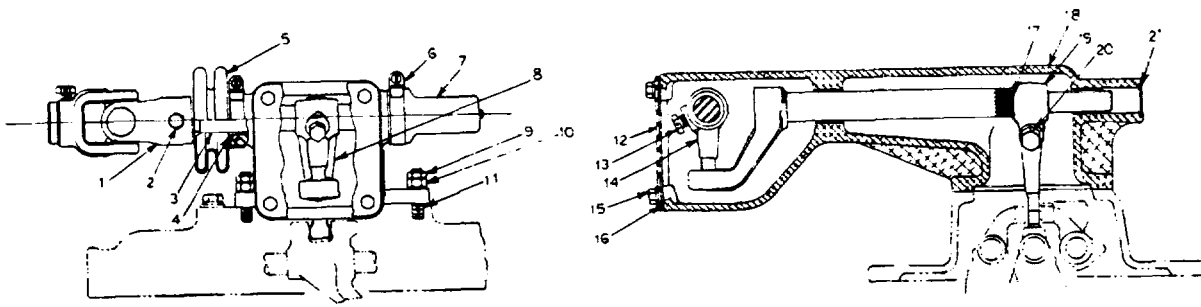

REF. NO.	PART NUMBER	DESCRIPTION	NO. REQ'D
SLAVE UNIT CONTROL ASSEMBLY			
	7-352-000027	Slave Unit Control Assembly	
1	9-352-100001	"U" Joint -----	1
2	9-352-100002	Screw, Lock-----	2
3	9-352-100003	Shaft, Outer-----	1
4	9-352-100004	Seal-----	2
5	9-352-100005	Boot -----	1
6	9-352-100006	Clamp-----	2
7	9-352-100007	Boot -----	1
8	9-352-100008	Shaft & Lever Assembly- - -----	1
9	9-352-100009	Nut, Jam -----	4
10	9-352-100010	Nut, Conical-----	4
11	9-352-100011	Stud -----	4
12	9-352-100012	Cover -----	1
13	9-904-101263	Screw, Lock-----	1
14	9-352-100013	Finger-----	1
15	9-352-100014	Capscrew -----	4
16	9-352-100015	Gasket-----	1
17	9-352-100016	Ring, Snap - - -----	1
18	9-352-100017	Housing - L.H. -----	1
19	9-352-100018	Finger-----	1
20	9-352-100019	Capscrew -----	1
21	9-352-100020	Plug -----	1

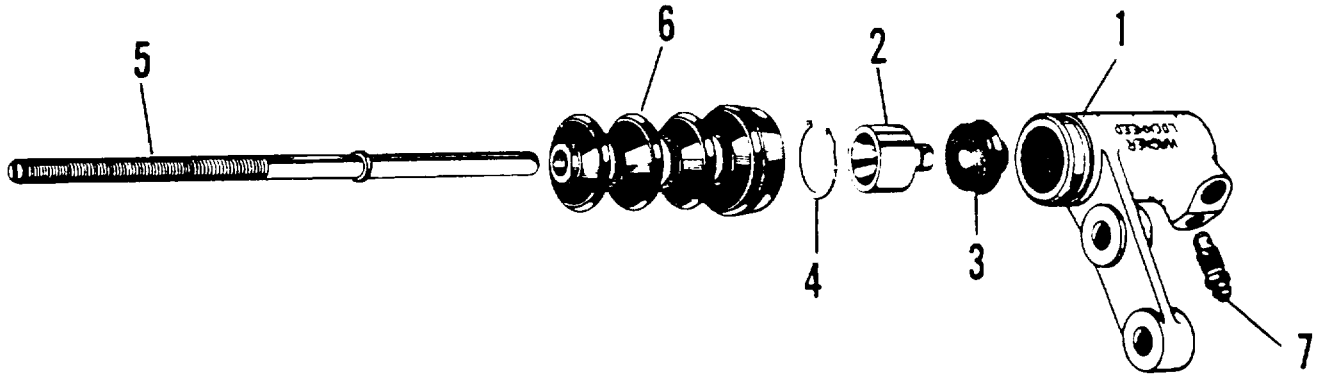

REF. NO.	PART NUMBER	DESCRIPTION	NO. REQ'D
SLAVE CYLINDER			
1	6-372-000742	Slave Cylinder Casting (To Replace, Order Complete Assembly)-	1
* 2	N.S.S.	Piston Assembly-	1
* 3	N.S.S.	Cup-	1
* 4	N.S.S.	Ring, Retaining-	1
5	N.S.S.	Rod, Push-	1
* 6	N.S.S.	Boot	1
7	9-372-100650	Screw, Bleeder	1
	9-752-100133	Kit, Repair-	1

*Parts Included In Repair Kit.

N.S.S. - Not Sold Separately.

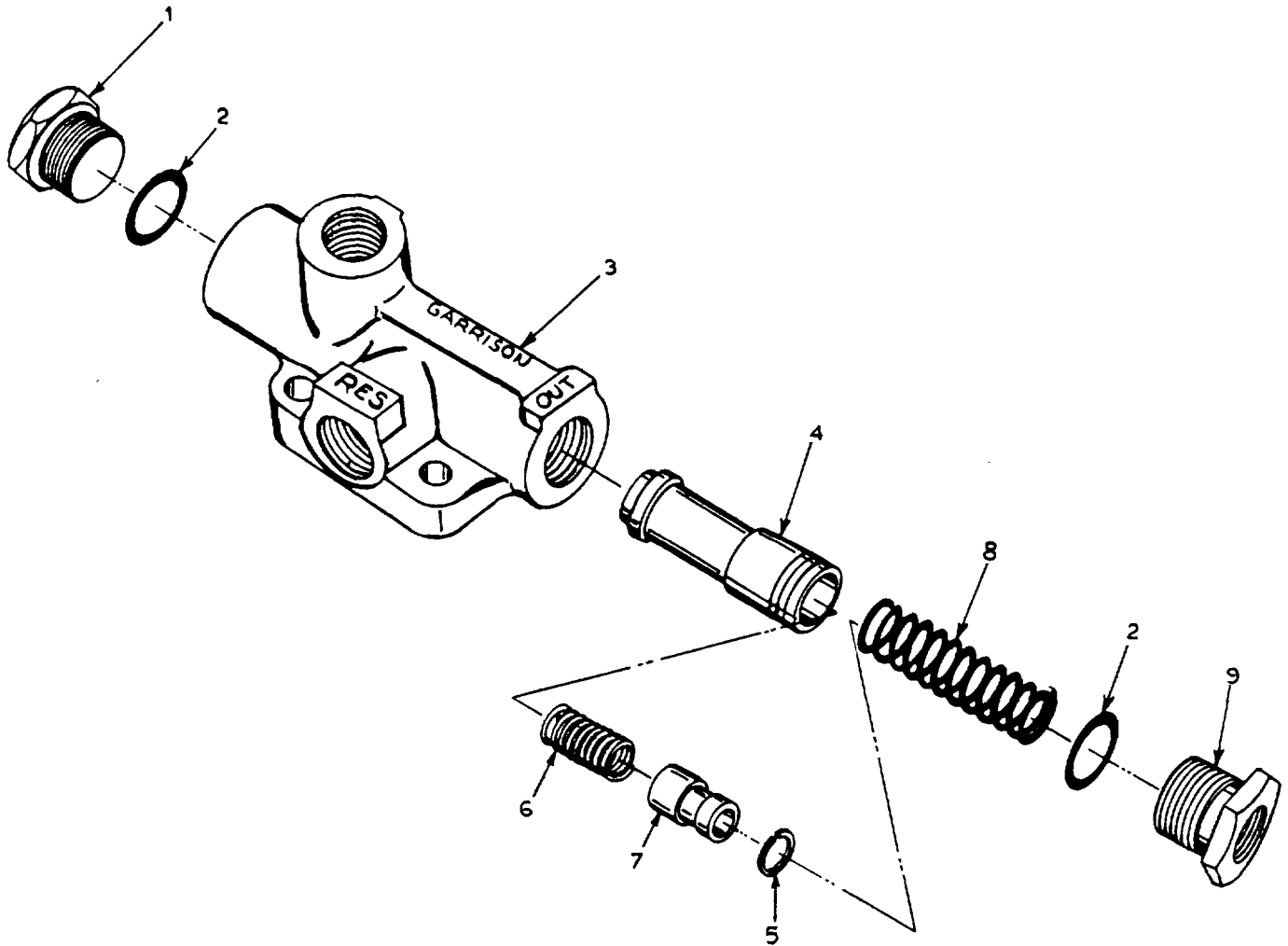

REF. NO.	PART NUMBER	DESCRIPTION	NO. REQ'D
FLOW CONTROL VALVE WITH RELIEF VALVE			
	7-926-000542	Flow Control Valve W/Relief Valve	
1	9-926-101441	Plug, End -----	1
2	9-926-101442	"O" Ring -----	2
3	9-926-101443	Body -----	1
*4	9-926-101518	Valve, Flow Control - -----	1
*5	9-926-101445	Ring, Retainer -----	1
*6	9-926-101517	Spring -----	1
*7	9-926-101447	Valve, Relief - -----	1
8	9-926-101448	Spring -----	1
9	9-926-101449	Adapter - -----	1

*These Items May Be Ordered As An Assembly - (Flow Control Valve Assembly - 9-926-101516)

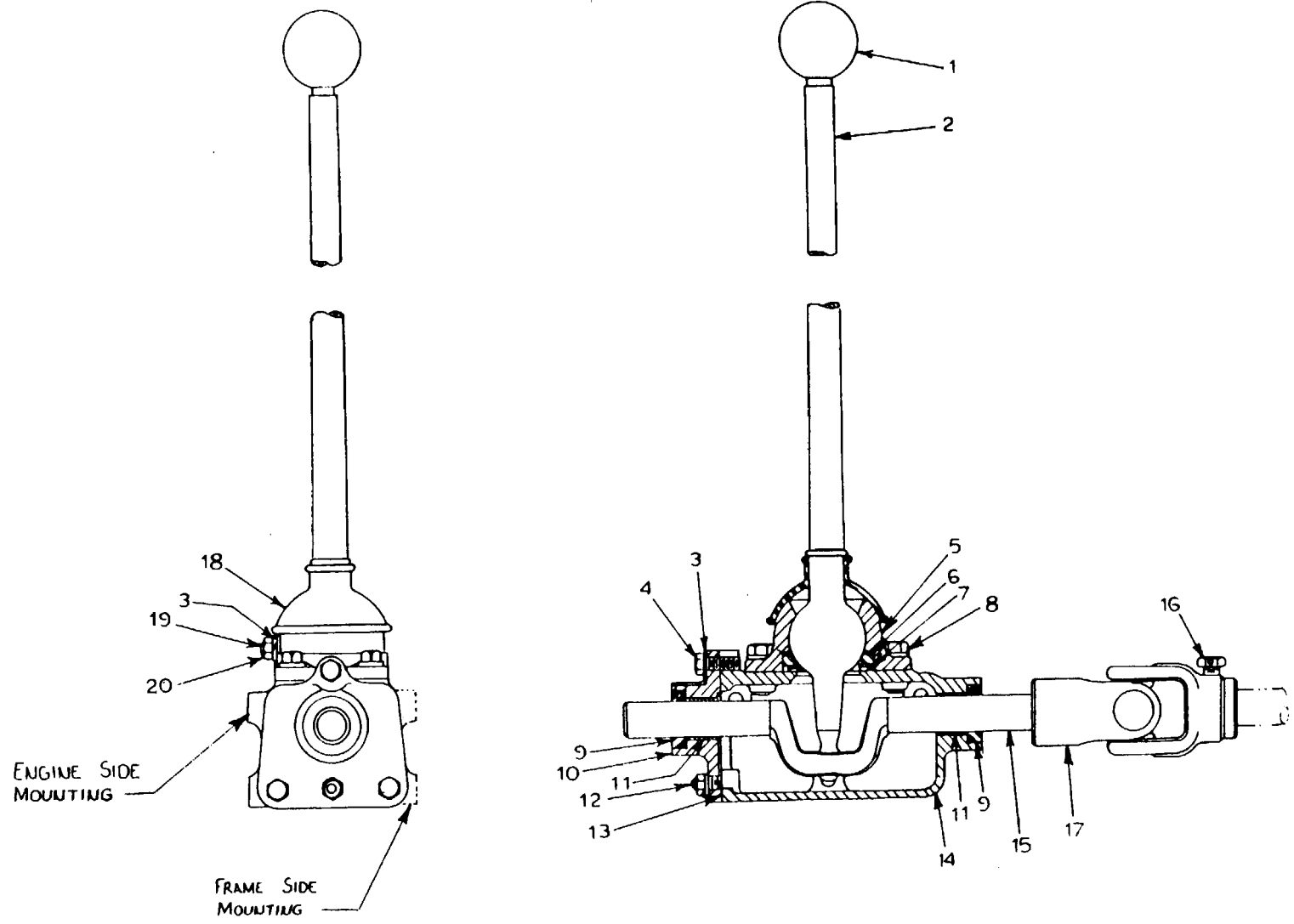

6-352-000034

B-143

REF. NO.	PART NUMBER	DESCRIPTION	NO. REQ'D
MASTER CONTROL UNIT ASSEMBLY			
1	9-904-101852	Ball -----	1
2	9-352-100021	Lever-----	1
3	9-904-101861	Washer, Lock-----	4
4	9-352-100022	Screw, Cap-----	3
5	9-352-100023	Cap-----	1
6	9-352-100024	Seat -----	1
7	9-352-100025	Washer-----	1
8	9-904-101813	Screw, Cap-----	4
9	9-352-100004	Seal -----	2
10	9-352-100026	Cap, End-----	1
11	9-352-100027	Bushing-----	2
12	9-352-100028	Fitting, Zert-----	1
13	9-352-100029	Gasket-----	1
14	9-352-100030	Housing -----	1
15	9-352-100031	Yoke, Shift-----	1
16	9-352-100002	Screw, Lock - -----	2
17	9-352-100001	"U" Joint -----	1
18	9-352-100032	Boot -----	1
19	9-904-101860	Pin-----	1
20	9-904-101862	Nut-----	1

6-352-000034

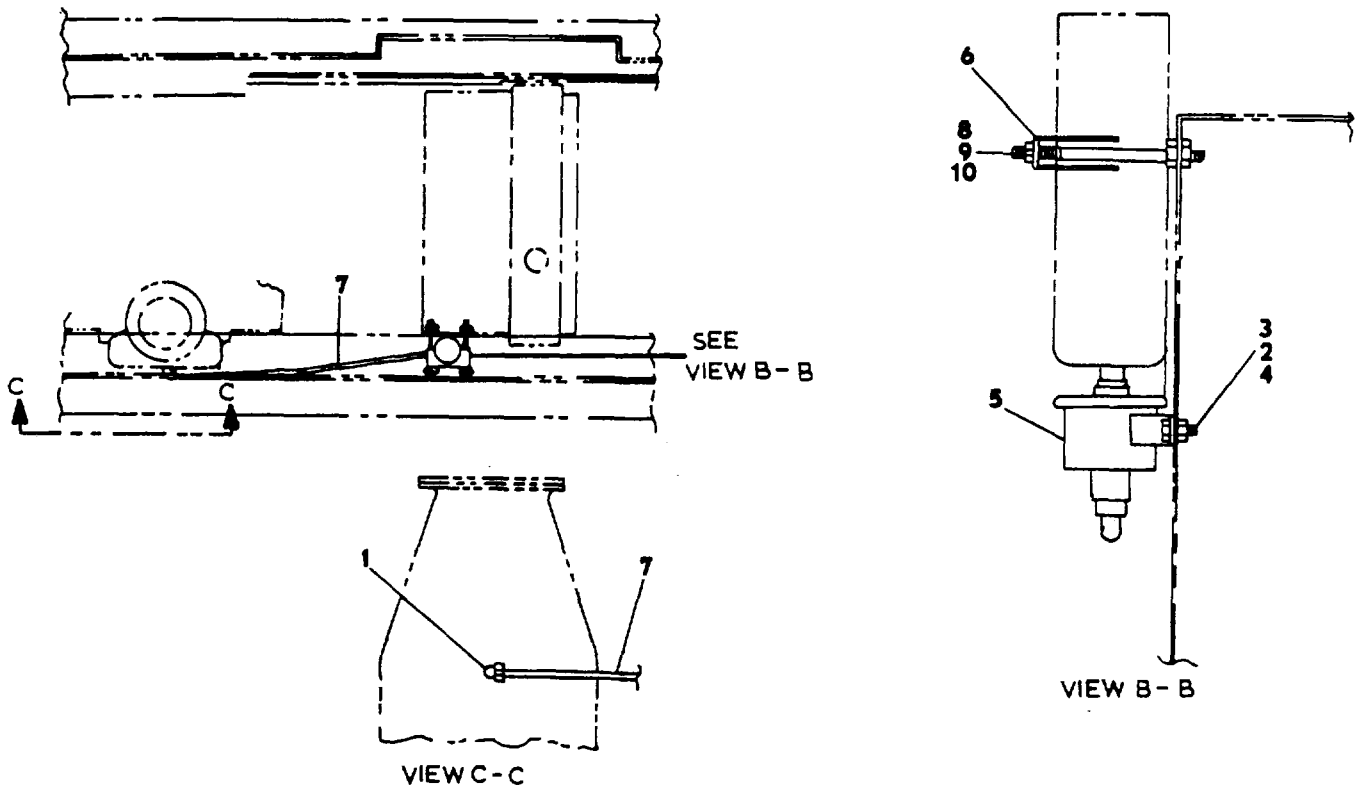

REF. NO.	PART NUMBER	DESCRIPTION	NO. REQ'D
QUICK START INSTALLATION			
1	7-845-000003	Atomizer - -----	1
2	MS35338-44	Lockwasher 1/4" Medium - Spring Steel - -----	2
3	MS90725-6	Bolt, Hex Head 1/4" x 3/4" N.C. - Grd. 1 -----	2
4	MS51967-2	Nut, Hex 1/4" N.C. - Grade A -----	2
5	7-926-000531	Valve Assembly - 12V. - -----	1
6	7-300-000160	Clamp, Cylinder - -----	1
7	6-910-001240	Tube, Nylon -----	1
8	MS90725-31	Bolt, Hex Head 5/16"-18 N.C. x 5/8" Length - Grade 1 -----	2
9	MS35338-45	Lockwasher 5/16" Medium - Spring Steel -----	2
10	MS51967-5	Nut, Hex 5/16"-18 N.C. - Grade A-----	2

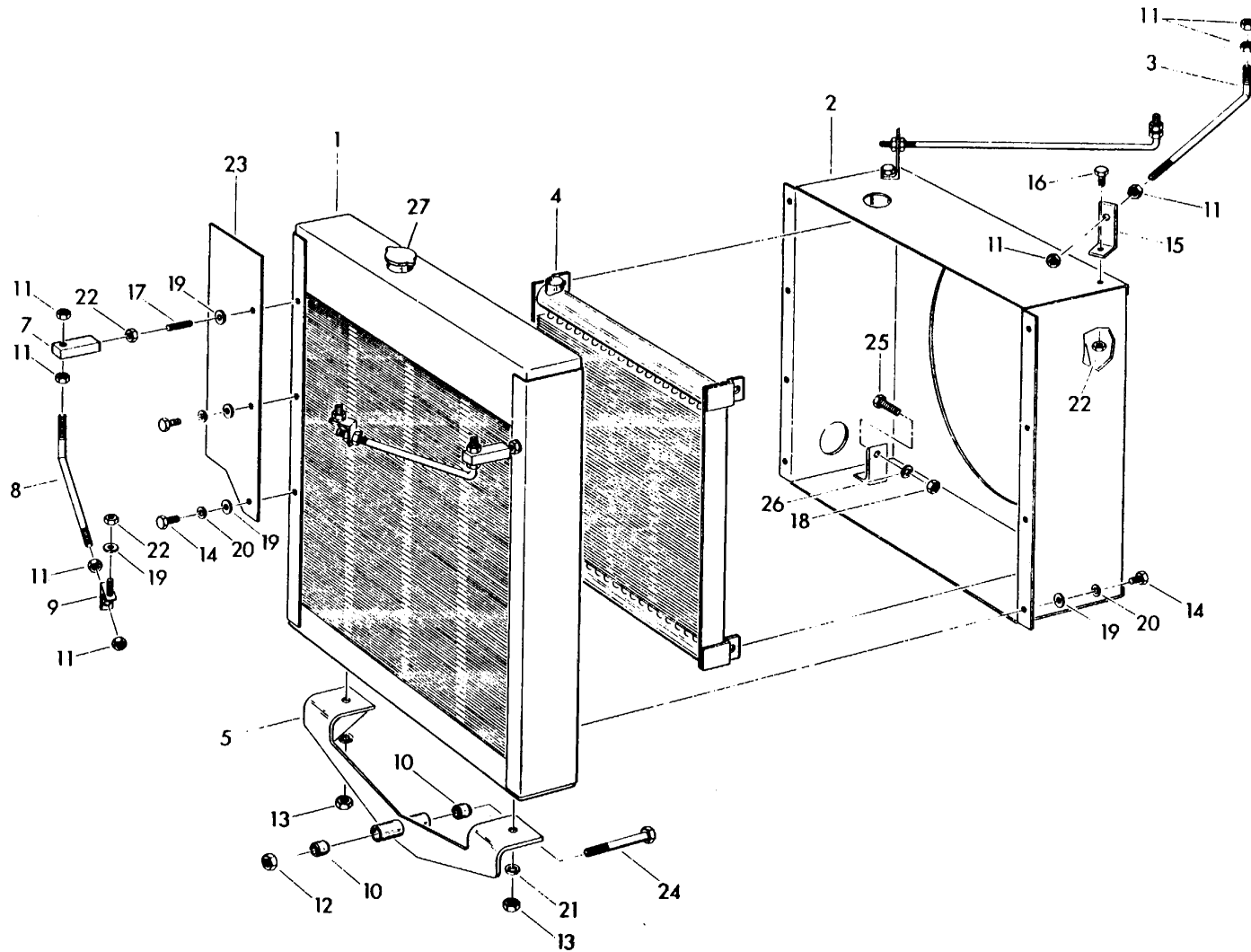

6-726-000076

B-146

REF. NO.	PART NUMBER	DESCRIPTION	NO. REQ'D
RADIATOR & OIL COOLER INSTALLATION			
1	7-726-000061	Radiator -----	1
2	2-137-8-00037	Shroud Assembly -----	1
3	6-768-000582	Rod -----	2
4	7-726-000017	Oil Cooler Assembly -----	1
5	6-869-000299	Trunnion Weldment -----	1
7	4-126-8-00023	Block, Mounting -----	2
8	4-126-8-00036	Rod -----	2
9	2-126-8-00007	Mounting Angle Weldment -----	2
10	7-638-000056	Mounting, Shock -----	2
11	MS51922-17	Locknut, Hex 3/8"-16 N.C. - Grade A-----	16
12	MS51922-49	Locknut, Hex 5/8"-11 N.C. - Grade A -----	1
13	MS51967-14	Nut, Hex 1/2"-13 N.C. - Grade A -----	2
14	MS90725-29	Bolt, Hex Head 5/16"-18 N.C. x 1/2" Length Grade 1 -----	10
15	6-030-000901	Angle, Mounting -----	2
16	MS90725-34	Bolt, Hex Head 5/16"-18 N.C. x 1" Length - Grade 1 -----	2
17	6-865-151660	Stud -----	2
18	MS51967-8	Nut, Hex 3/8"-16 N.C. - Grade A -----	4
19	MS27183-12	Flatwasher 11/32" I.D. x 11/16" O.D. x .065 Thick - Steel-----	14
20	MS35338-45	Lockwasher 5/16" Medium - Spring Steel -----	10
21	MS35338-48	Lockwasher 1/2" Medium - Spring Steel -----	2
22	MS51922-9	Locknut, Hex 5/16"-18 N.C. - Grade A - -----	6
23	6-705-006088	Plate -----	1
24	MS90725-177	Bolt, Hex Head 5/8"-11 N.C. x 5 1/2" Length - Grade 5-----	1
25	MS90725-60	Bolt, Hex Head 3/8"-16 N.C. x 1" Length - Grade 1 -----	4
26	MS35338-46	Lockwasher 3/8" Medium - Spring Steel -----	4
27	9-726-100029	Cap, Radiator -----	1

6-726-000076

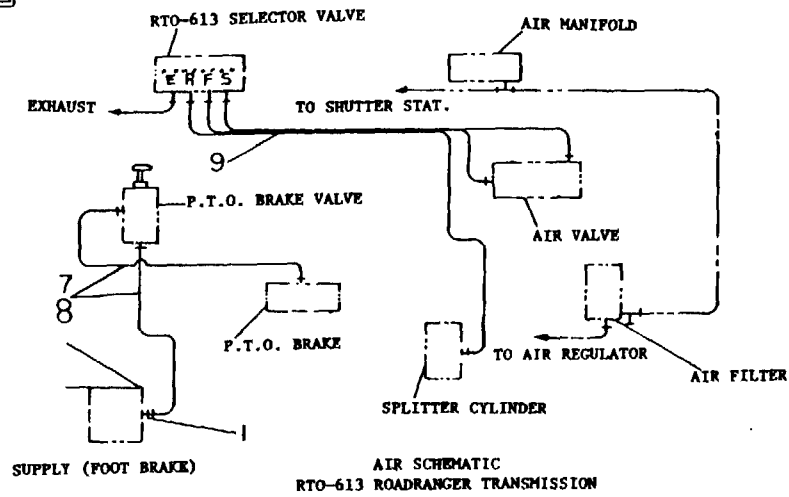
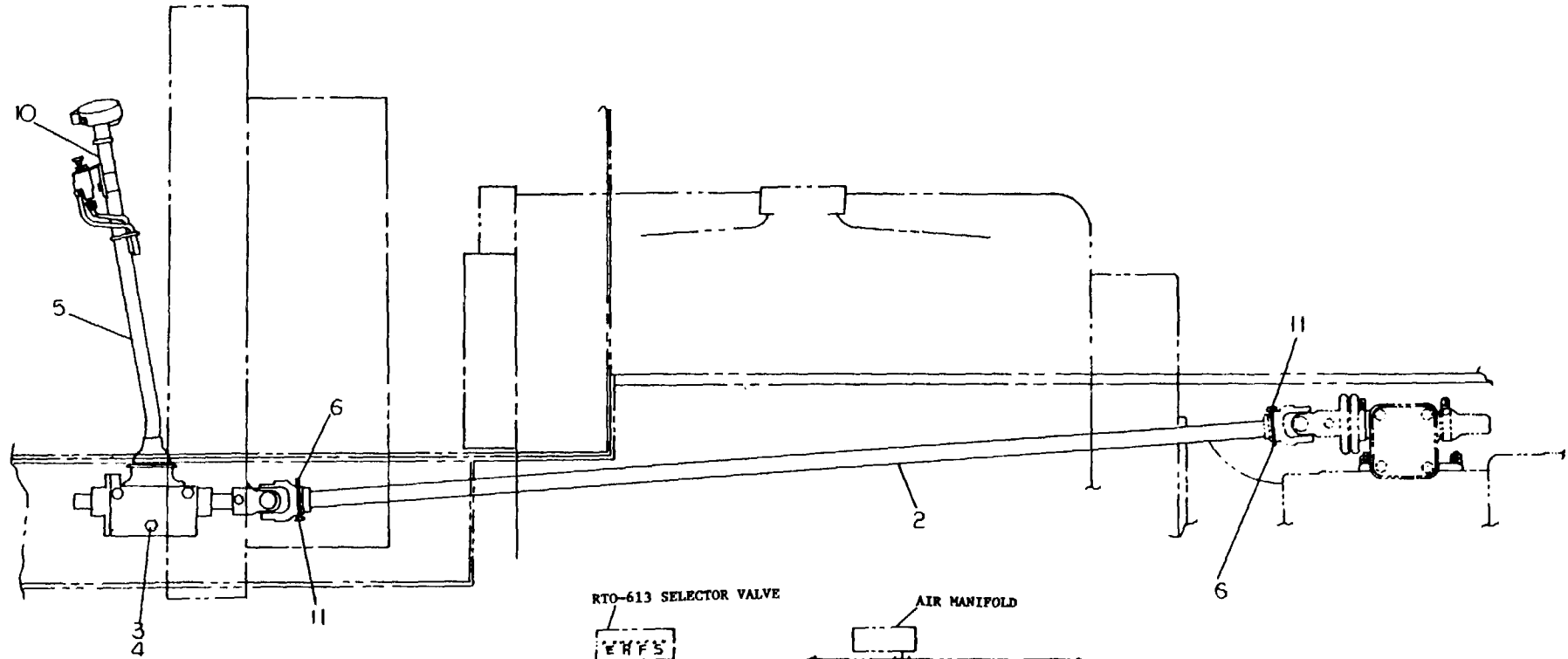

REF. NO.	PART NUMBER	DESCRIPTION	NO. REQ'D
TRANSMISSION SHIFT INSTALLATION			
1	7-444-020156	Bushing, Hex Reducer -----	1
2	4-137-8-00199	Rod, Connecting -----	1
3	MS90725-62	Bolt, Hex. Head 3/8" x 1 1/4" N.C. (Grade 1) -----	3
4	MS35338-46	Washer, Lock 3/8" Med. - Spring Steel -----	3
5	6-352-000034	Master Control Unit -----	1
6	6-978-000263	Wire, Safety-----	2
7	6-910-001212	Tubing, Nylaflo -----	1
8	6-557-000019	Loom, Wiring -----	1
9	6-910-001271	Bundle, 3 Tube -----	1
10	6-768-000553	Rod, Extension - -----	1
11	7-099-000215	Screw, Set-----	2

2-130-8-00009 (D)

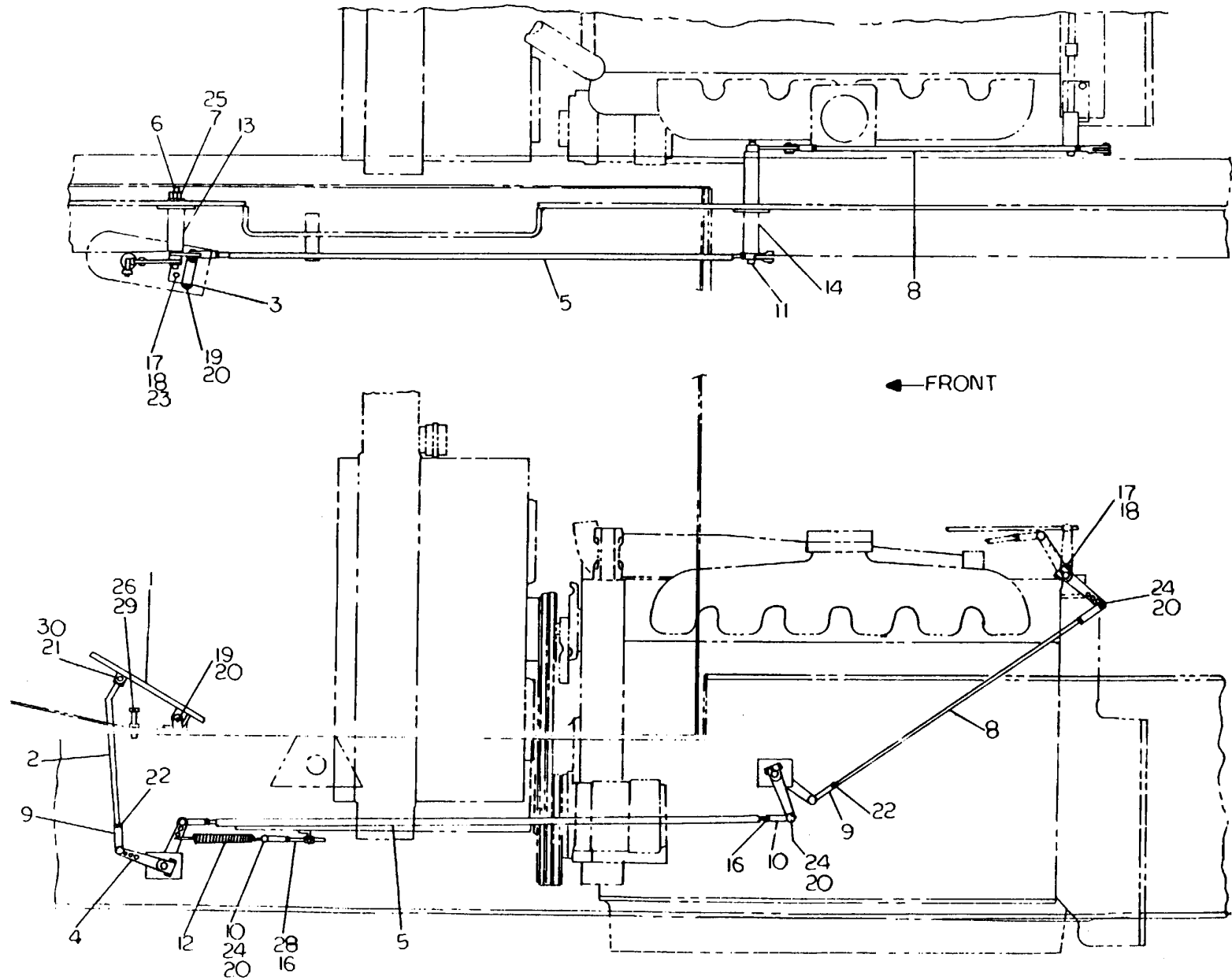

2-130-8-00025

B-150

REF. NO.	PART NUMBER	DESCRIPTION	NO. REQ'D
THROTTLE INSTALLATION (GMC 6-71N)			
1	6-683-000017	Pedal, Foot-----	1
2	2-130-8-00047	Throttle Rod Weldment -----	1
3	4-137-8-00288	Bracket, Mounting -----	1
4	7-593-000089	Lever, Control -----	5
5	2-130-8-00027	Rod Weldment -----	1
6	4-137-8-00272	Rod-----	1
7	6-199-000838	Bushing-----	1
8	6-768-000531	Rod-----	1
9	7-308-000014	Yoke, Rod End-----	3
10	7-308-000077	yoke -----	3
11	6-768-000532	Rod-----	1
12	7-834-000015	Spring, Governor -----	1
13	2-130-8-00028	Bushing, Weldment & Assembly -----	1
14	2-130-8-00029	Bushing Weldment & Assembly -----	1
16	MS51968-2	Nut, Hex. 1/4" N.F. (Grade A) -----	5
17	MS90725-7	Bolt, Hex. Head 1/4"x7/8" N.C. (Grade 1)-----	5
18	MS35338-44	Washer, Lock 1/4" Med. - Spring Steel-----	7
19	7-690-155000	Pin, Clevis 5/16" x 3 1/8" Steel -----	1
20	MS24665-368	Pin, Cotter 1/8" x 3/4" Steel-----	7
21	7-950-150161	Washer, Flat 3/8" x 3/4" x .065 - Spring Steel -----	1
22	MS51968-5	Nut, Hex. 5/16" N.F. (Grade A) -----	3
23	MS51967-2	Nut, Hex. 1/4" N.C. (Grade A)-----	2
24	MS35810-4	Pin, Clevis 5/16" x 1" Steel -----	6
25		Screw, Set 1/4" - 20 N.C. -----	1
26	MS90725-65	Bolt, Hex. Head 3/8" x 1 3/4" N.C. (Grade 1) -----	1
28	6-685-142870	Stud 1/4" x 3 1/2" N.F.- -----	1
29	MS35691-17	Nut, Hex. Jam 3/8" N.C. (Grade A) -----	1
30	MS24665-153	Pin, Cotter 1/16" x 3/4" Steel -----	1

2-130-8-00025 (E)

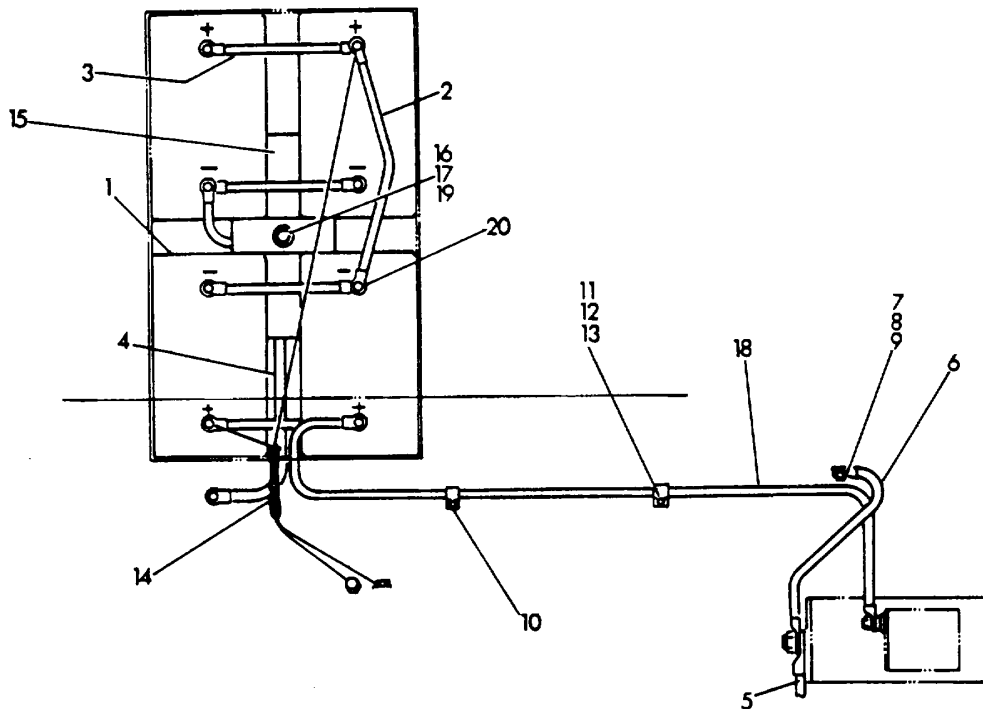

REF. NO.	PART NUMBER	DESCRIPTION	NO. REQ'D
BATTERY INSTALLATION			
1	7-064-000017	Battery-----	4
2	6-246-000561	Cable, Battery -----	1
3	6-246-000615	Cable, Battery -----	4
4	2-137-8-00033	Cable, Battery -----	1
5	6-246-000354	Cable, Battery -----	1
6	7-850-000046	Strap, Engine Ground -----	1
7	7-866-163120	Stud Weldment-----	2
8	MS27183-14	Flatwasher - 13/32" I.D. x 13/16" O.D. x .065 Thick - Steel -----	2
9	MS51922-17	Nut, Lock - 3/8"-16 N.C. - Grade A-----	2
10	7-300-000102	Clamp, Tubing-----	2
11	7-866-143120	Stud Weldment-----	2
12	MS27183-10	Flatwasher - 9/32" I.D. x 5/8" O.D. x .065 Thick - Steel -----	2
13	MS51922-1	Nut, Lock - 1/4"-20 N.C. - Grade A-----	2
14	7-978-000470	Wiring Harness Assembly-----	1
15	2-177-8-00188	Battery Tie Down Weldment-----	1
16	2-137-1-00025	Stud Weldment-----	1
17	MS27183-13	Flatwasher - 3/8" I.D. x 7/8" O.D. x .083 Thick - Steel -----	3
18	6-246-000287	Cable, Battery -----	1
19	MS51922-9	Locknut - 5/16"-18 N.C. - Grade A -----	1
20	7-660-160008	Nut, Hex-----	8

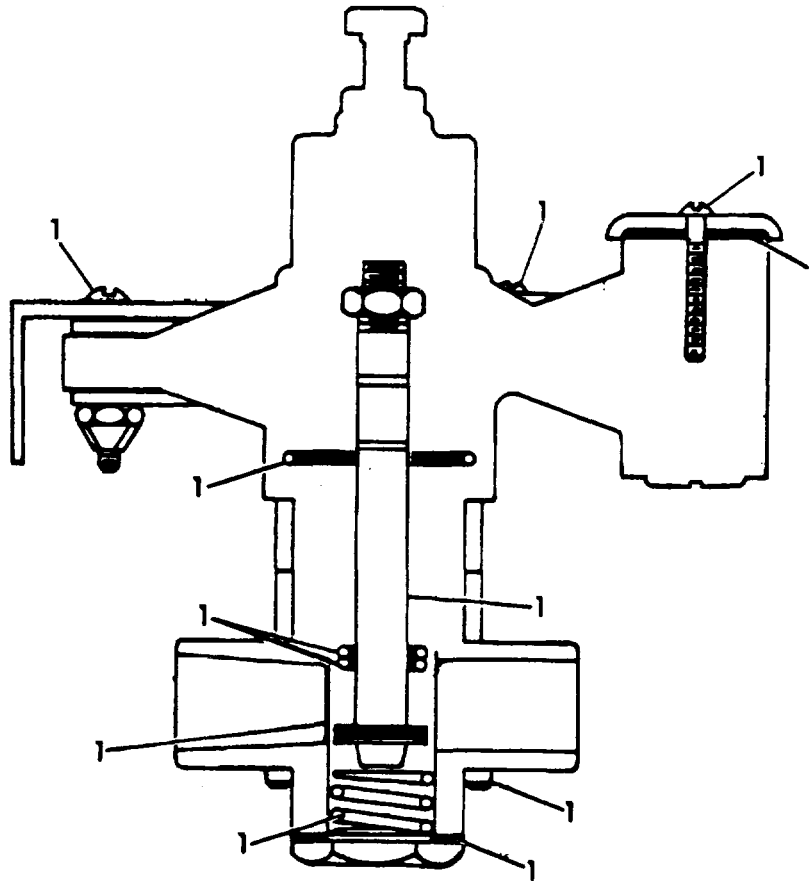

REF. NO.	PART NUMBER	DESCRIPTION	NO. REQ'D
RELAY VALVE			
1	7-926-000806	Relay Valve	1
	9-926-102355	Repair Kit -----	
7-926-000806			

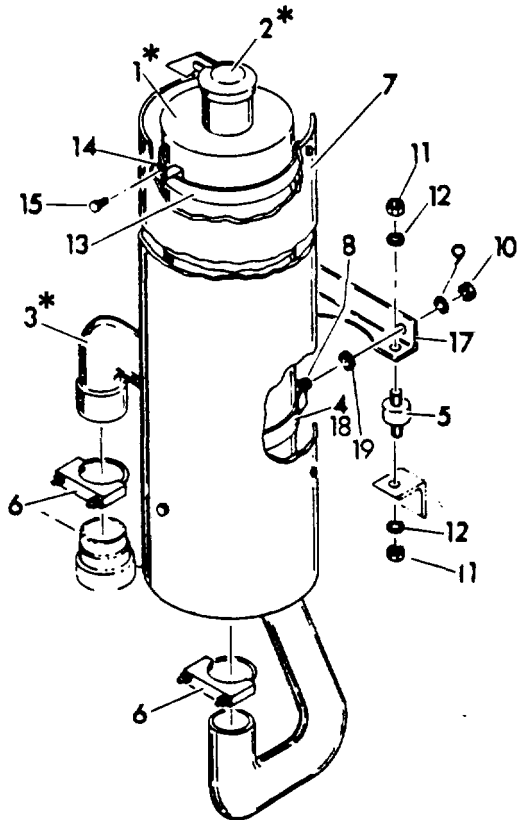

* Part numbers denoted by an asterisk identify those items that comprise the anti-tampering portion of 40 CFR Part 205 EPA noise regulation. Prior to replacement, refer to your service manual for a complete list of these items that meet the criteria and is consistent with the "list of tampering acts" published in your operators handbook.

REF. NO.	PART NUMBER	DESCRIPTION	NO. REQ'D
----------	-------------	-------------	-----------

EXHAUST SYSTEM INSTALLATION

*1	7-642-000045	Muffler -----	1
*2	7-258-000303	Cap, Weather-----	1
*3	7-910-004090	Tube, Exhaust-----	1
4	7-304-000013	Band, Mounting -----	1
5	7-638-000092	Mount, Shear Sandwich-----	2
6	7-300-000047	Clamp, Muffler -----	2
7	6-814-000184	Guard, Muffler-----	1
8	MS90725-32	Bolt, Hex Head 5/16"-18 N.C. x 3/4" Length Grade 1 -----	2
9	MS35338-45	Lockwasher 5/16" Medium - Spring Steel -----	2
10	MS51967-5	Nut, Hex 5/16"-18 N.C. - Grade A-----	2
11	MS51967-2	Nut, Hex 1/4"-20 N.C. - Grade A -----	4
12	MS35338-44	Lockwasher 1/4" Medium - Spring Steel-----	4
13	7-300-000204	Clamp-----	2
14	6-312-000048	Clip-----	6
15	7-791-141250	Screw, Hex Washer Head Self Drilling 1/4" -20 N.C. x 3/4" Legnth - Grade 1 -----	6
17	6-030-001355	Angle, Mounting-----	1
18	MS90725-40	Bolt, Hex Head 5/16"-18 N.C. x 2" Length - Grade 1 -----	1
19	MS27183-12	Flatwasher .344 I.D. x .688 O.D. x .065 Thick - Steel -----	2

6-304-000053

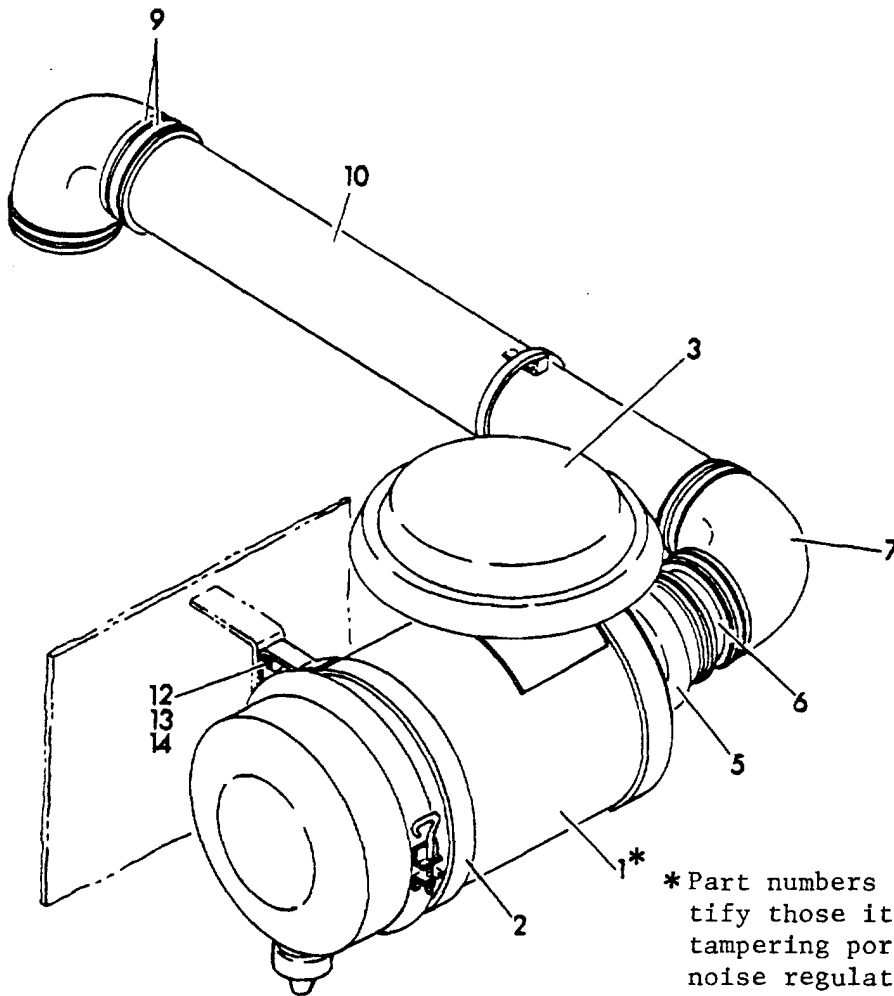

*Part numbers denoted by an asterisk identify those items that comprise the anti-tampering portion of 40 CFR Part 205 EPA noise regulation. Prior to replacement, refer to your service manual for a complete list of these items that meet the criteria and is consistent with the "list of tampering acts" published in your operators handbook.

REF. NO.	PART NUMBER	DESCRIPTION	NO. REQ'D
AIR CLEANER INSTALLATION			
*1	7-304-000024	Air Cleaner -----	1
2	7-056-000008	Band, Mounting -----	2
3	7-258-000251	Hood, Air Inlet -----	1
5	7-013-000204	Adapter, Straight Rubber -----	1
6	6-200-489634	Bushing-----	1
7	7-406-000101	Elbow -----	2
9	7-300-000088	Clamp-----	13
10	6-910-002275	Tube -----	1
12	MS90725-85	Bolt, Hex Head 7/16"-14 N.C. x 1" Length - Grade 1-----	4
13	MS51967-11	Nut, Hex 7/16"-14 N.C. - Grade A -----	4
14	MS35338-47	Lockwasher 7/16" Medium - Spring Steel -----	4

6-304-000036 (B)

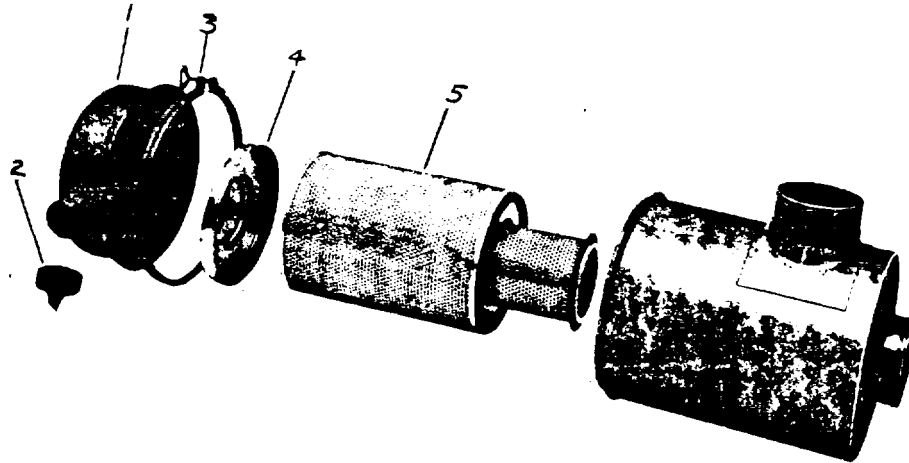

REF. NO.	PART NUMBER	DESCRIPTION	NO. REQ'D
		AIR CLEANER ASSEMBLY	
	7-304-000024	Air Cleaner Assembly	
1	9-304-100004	Cup Assembly -----	1
2	9-304-100005	Valve, Vacuumator -----	1
3	9-304-100002	Clamp Assembly -----	1
4	9-304-100003	Baffle Assembly -----	1
5	9-304-100001	Element Assembly -----	1

7-304-000024

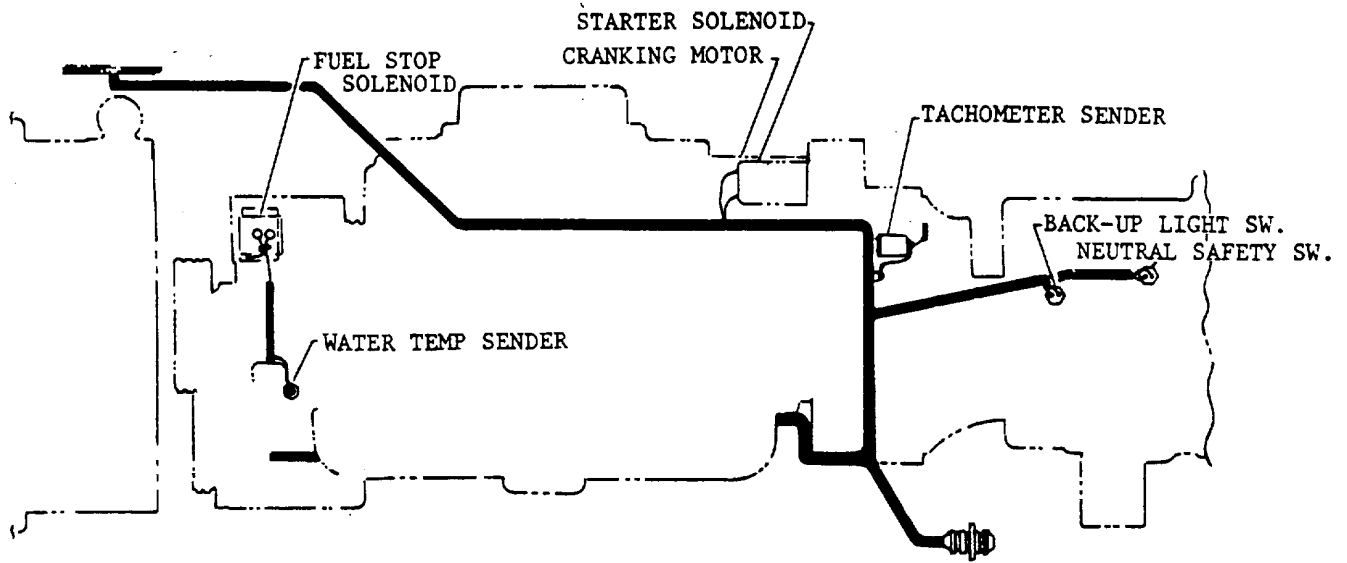

REF. NO.	PART NUMBER	DESCRIPTION	NO. REQ'D
ENGINE HARNESS INSTALLATION - G.M.C. 6-71N			
1	7-978-000504	Wiring Harness Assembly G.M.C. 6-71N-----	1
2	7-300-000100	Clamp, Tubing-----	3
3	MS90725-55	Capscrew. Hex Henrad /8"-16 N.C. x 1/2" Length - Grade 1-----	2

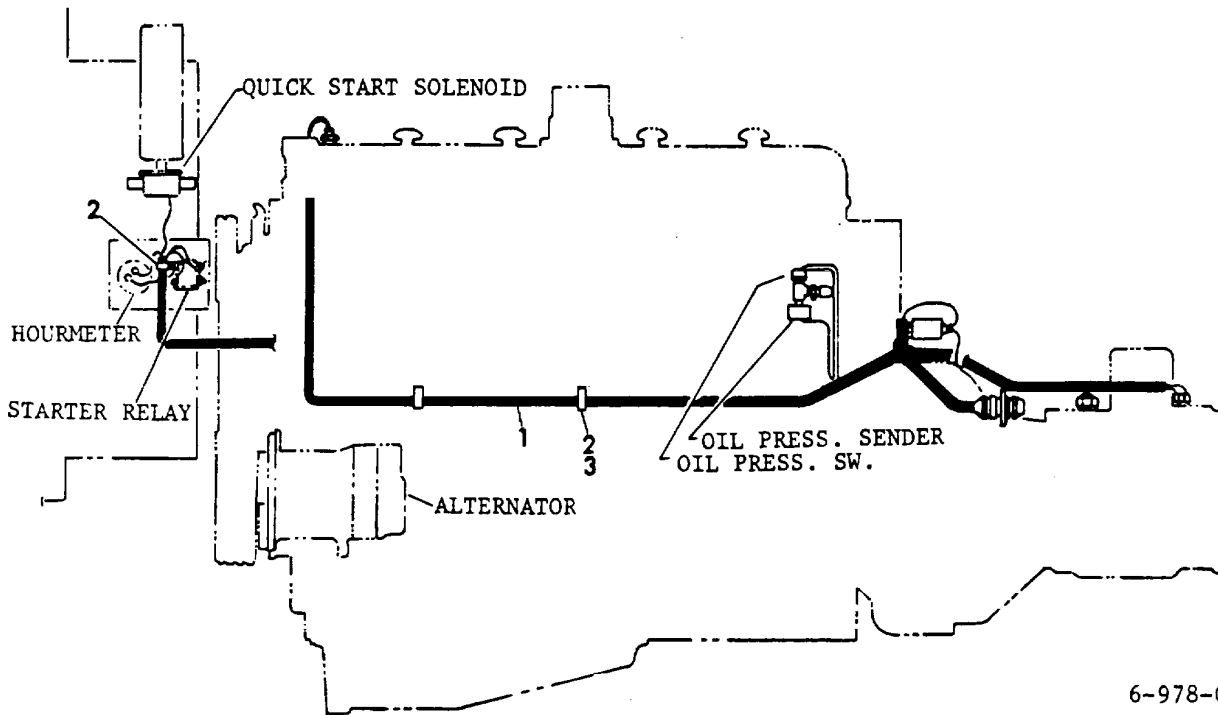

6-978-000505

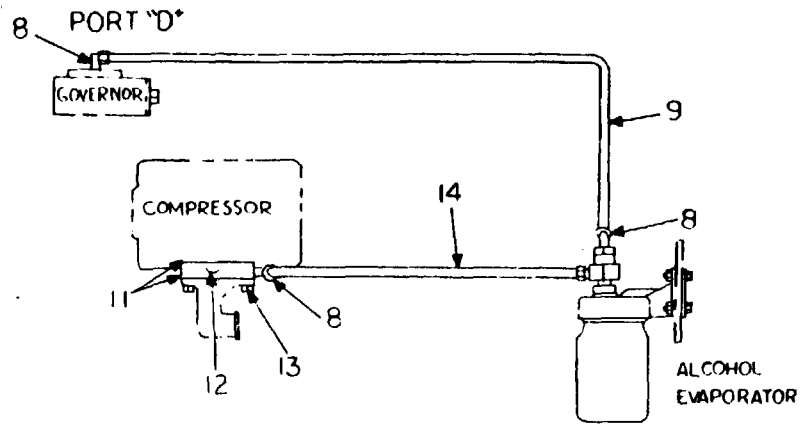

ALCOHOL EVAPORATOR - AIR SCHEMATIC
GMC - 6-7IN ENGINE

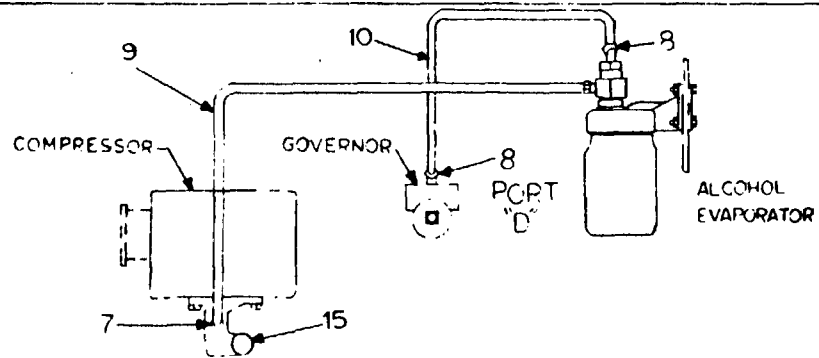

ALCOHOL EVAPORATOR - AIR SCHEMATIC
CUMMINS - NHF-240 ENGINE

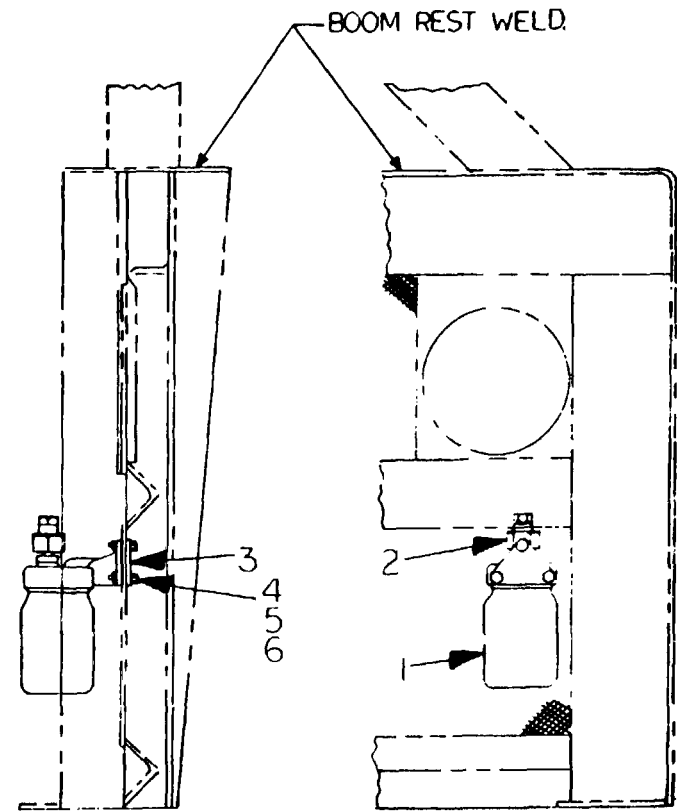

ALCOHOL EVAPORATOR INSTALL

REF. NO.	PART NUMBER	DESCRIPTION	NO. REQ'D
ALCOHOL EVAPORATOR INSTALLATION (GMC 6-71)			
1	7-348-000062	Evaporator, Alcohol -----	1
2	7-926-000530	Valve, Check -----	1
3	4-137-1-00290	Plat, Mounting -----	1
4	MS90725-8	Bolt, Hex Had 1/4" x 1" N.C. - Gr. 1 -----	3
5	MS35338-44	Lockwasher 1/4" Medium - Spring Steel -----	3
6	MS51967-2	Nut, Hex 1/4" N.C. - Grad A -----	3
7	Not Required		
8	7-445-020204	Adapter, Swivel -----	3
9	7-542-001601	Hs Assembly -----	1
10	Not Required		
11	7-794-000288	Gasket, Strainer -----	2
12	7-013-000195	Adapter -----	1
13	MS90725-44	Bolt, Hex Had 5/16" x 3 N.C. - Gr. 1 -----	2
14	7-542-002401	Hs Assembly -----	1
15	Not Required		

USE DRAWING
6-294-001067
2-137-1-00138 (B)

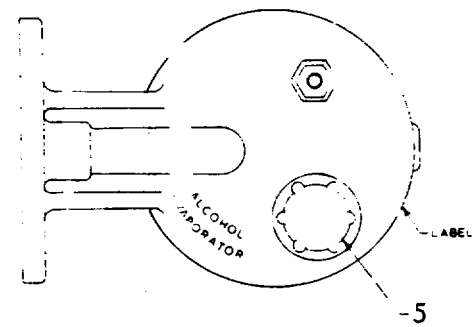
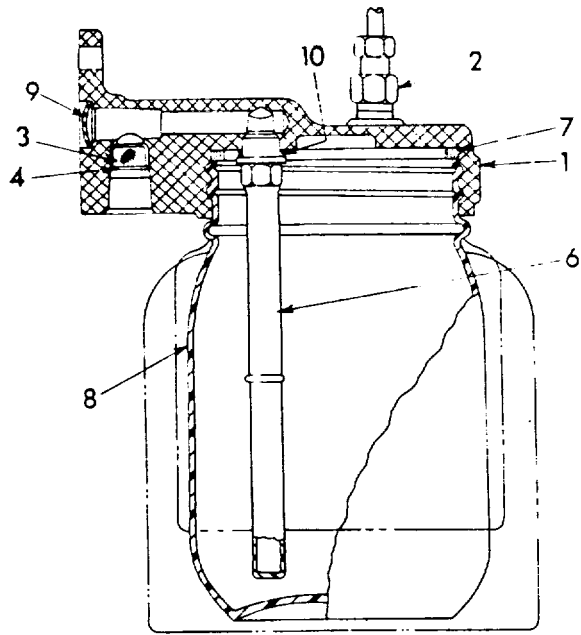

REF. NO.	PART NUMBER	DESCRIPTION	NO. REQ'D
ALCOHOL EVAPORATOR			
	7-348-000062	Alcohol Evaporator-----	
1	9-348-100026	Body -----	1
2	9-348-100027	Connector, Tubing -----	1
3	9-348-100028	Filter -----	1
4	9-348-100029	Ring, Retaining-----	1
5	9-348-100030	Plug, Filler-----	1
6	9-348-100031	Tub, Evaporator -----	1
7	9-348-100032	Gasket-----	1
8	9-348-100033	Jar, Plastic - Pint -----	1
9	9-348-100034	Plug, Welch -----	1
10	9-348-100035	Ring, Sealing -----	1

7-348-000062

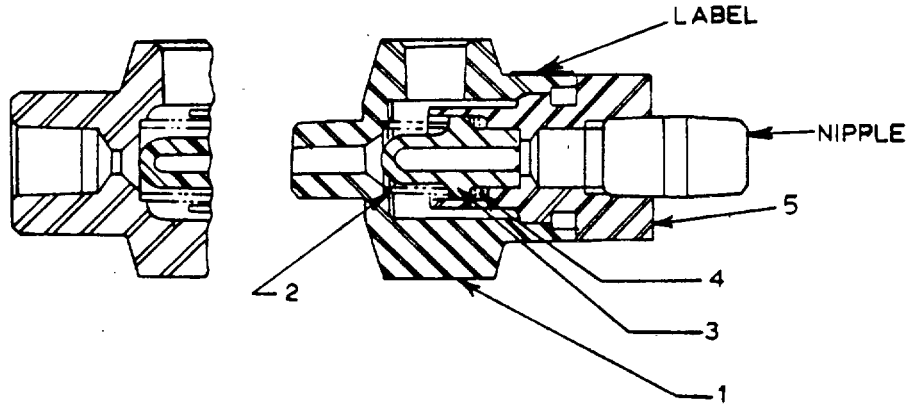

REF. NO.	PART NUMBER	DESCRIPTION	NO. REQ'D
		CHECK VALVE (ALCOHOL EVAPORATOR)	
	7-926-000530	Check Valve (Alcohol Evaporator)	
1	9-926-101380	Body -----	1
2	9-926-101381	Spring -----	1
3	9-926-101382	Valve -----	1
4	9-926-101383	Grommet -----	1
5	9-926-101384	Nut-----	1

7-926-000530

B-161

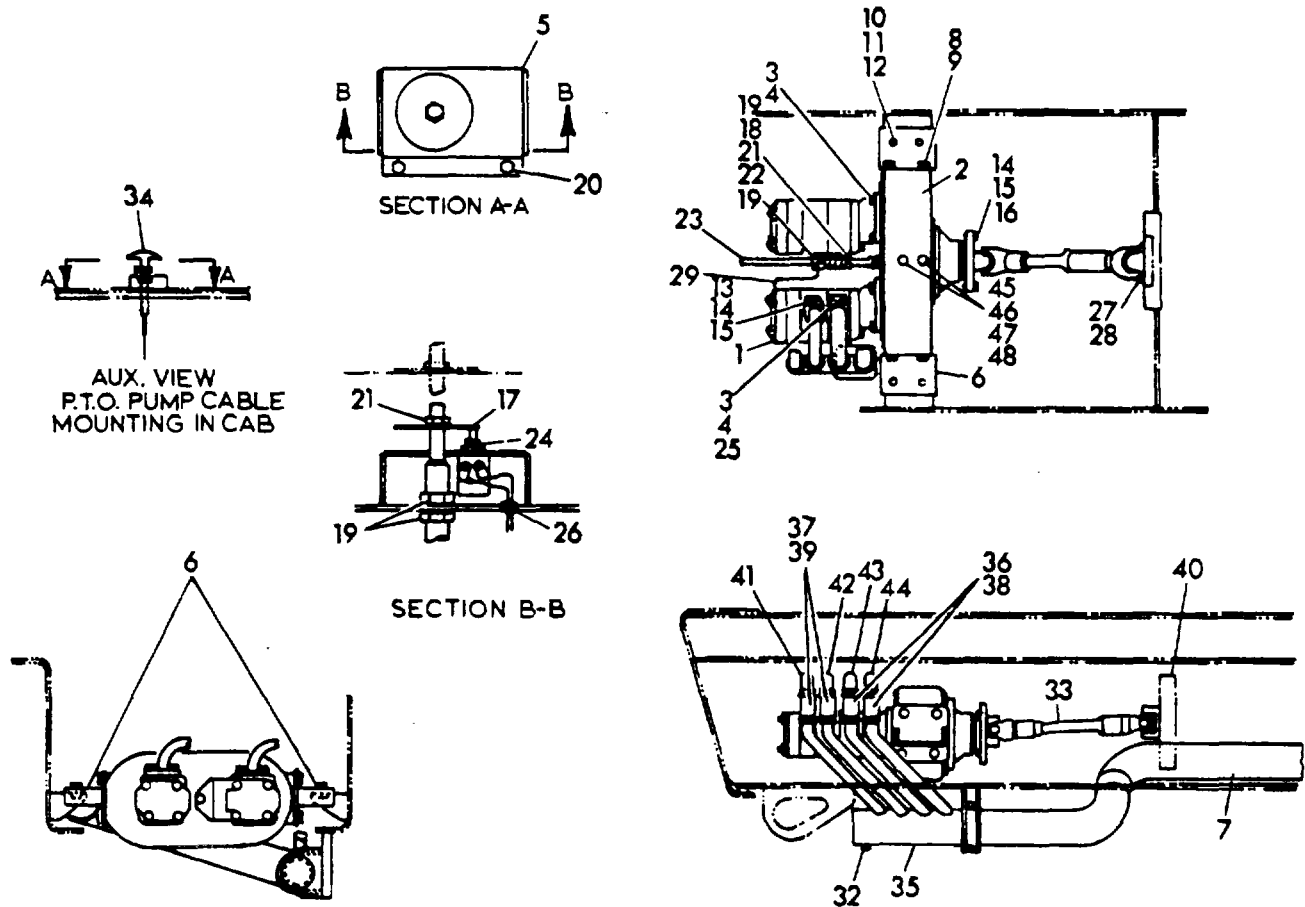

REF. NO.	PART NUMBER	DESCRIPTION	NO. REQ'D
PUMP & MANIFOLD INSTALLATION- G.M.C. 6-71N			
1	7-722-000054	Pump, Two Section -----	2
2	7-722-000085	Pump Drive W/Disconnect-----	1
3	MS90725-110	Bolt, Hex Had 1/2"-13 N.C. x 1 1/4" Length - Grad 1 -----	16
4	MS35338-48	Lockwasher 1/2" Medium - Spring Steel-----	16
5	2-137-8-00049	Box Weldment -----	1
6	2-137-8-00085	Pump Drive Mount Weldment-----	2
7		Hydraulic Section Tub Installation - See Separate Parts List-----	1
8	MS90725-159	Bolt, Hex Head 5/8"-11 N.C. x 1 1/4" Length - Grad 1 -----	8

6-722-000125

REF. NO.	PART NUMBER	DESCRIPTION	NO. REQ'D
PUMP & MANIFOLD INSTALLATION - G.M.C. 6-71N			
9	MS35338-50	Lockwasher 5/8" Medium - Spring Steel-----	8
10	MS90725-138	Bolt, Hex Had 9/16"-12 N.C. x 1 1/2" Length - Grad 1 -----	4
11	MS35338-49	Lockwasher 9/16" Medium - Spring Steel -----	4
12	MS51967-17	Nut, Hex 9/16"-12 N.C. - Grad A -----	4
13	7-755-219000	"O" Ring-----	2
14	MS35338-46	Lockwasher 3/8" Medium - Spring Steel-----	16
15	MS90725-61	Bolt, Hex Had 3/8"-16 N.C. x 1 1/4" Length - Grad 1 -----	16
16	MS51967-8	Nut, Hex 3/8"-16 N.C. - Grad A -----	8
17	6-705-002277	Plat -----	1
18	7-072-000001	Bellows Assembly -----	1
19	MS51968-20	Nut, Hex 5/8"-18 N.F. - Grad A -----	4
20	7-790-100853	Screw, Hex Washer Had Tapping #10-24 THD. Form "C" x 1/2" Length-----	2
21	MS51968-8	Nut, Hex 3/8"-24 N.F. - Grad A -----	2
22	7-308-000083	Clevis -----	1
23	7-246-000183	Cable, Control -----	1
24	7-872-000044	Switch, Cylinder Lockout -----	1
25	7-755-225000	"O" Ring-----	2
26	7-506-000006	Grommet-----	1
27	MS35338-46	Lockwasher 3/8" Medium - Spring Steel-----	5
28	MS90725-61	Bolt, Hex Had 3/8"-16 N.C. x 1 1/4" Length - Grad 1 -----	5
29	4-137-8-00253	Bracket-----	1
30	6-290-000441	Channel -----	1
31	7-300-000047	Clamp, Muffler -----	1
32	AN932-3	Plug, Plug 1/4" N.P.T. - Carbon Steel-----	1
33	7-810-001415	Shaft, Propeller -----	1
34	7-511-000040	Swivel -----	1
35	7-910-003593	Suction Manifold Assembly -----	1
36	7-544-800690	Hose -----	2
37	7-544-700690	Hose -----	2
38	7-300-000172	Clap, Hs-----	8
39	7-300-000006	Clap, Hs-----	8
40	6-013-000177	Ring, Adapter -----	1
41	7-910-003596	Tub -----	1
42	7-910-003597	Tub -----	1
43	7-910-003595	Tub -----	1
44	7-910-003594	Tub -----	1
45	MS51953-81	Nipple, Pipe 1/2" Standard Black Pipe x 3 1/2" (Thread Both Ends)-----	1
46	7-444-000440	Coupling, Straight Pipe-----	1
47	7-444-080201	Bushing, Hex Reducing -----	1
48	7-934-000007	Vent, Air-----	1

6-722-000125 (A)

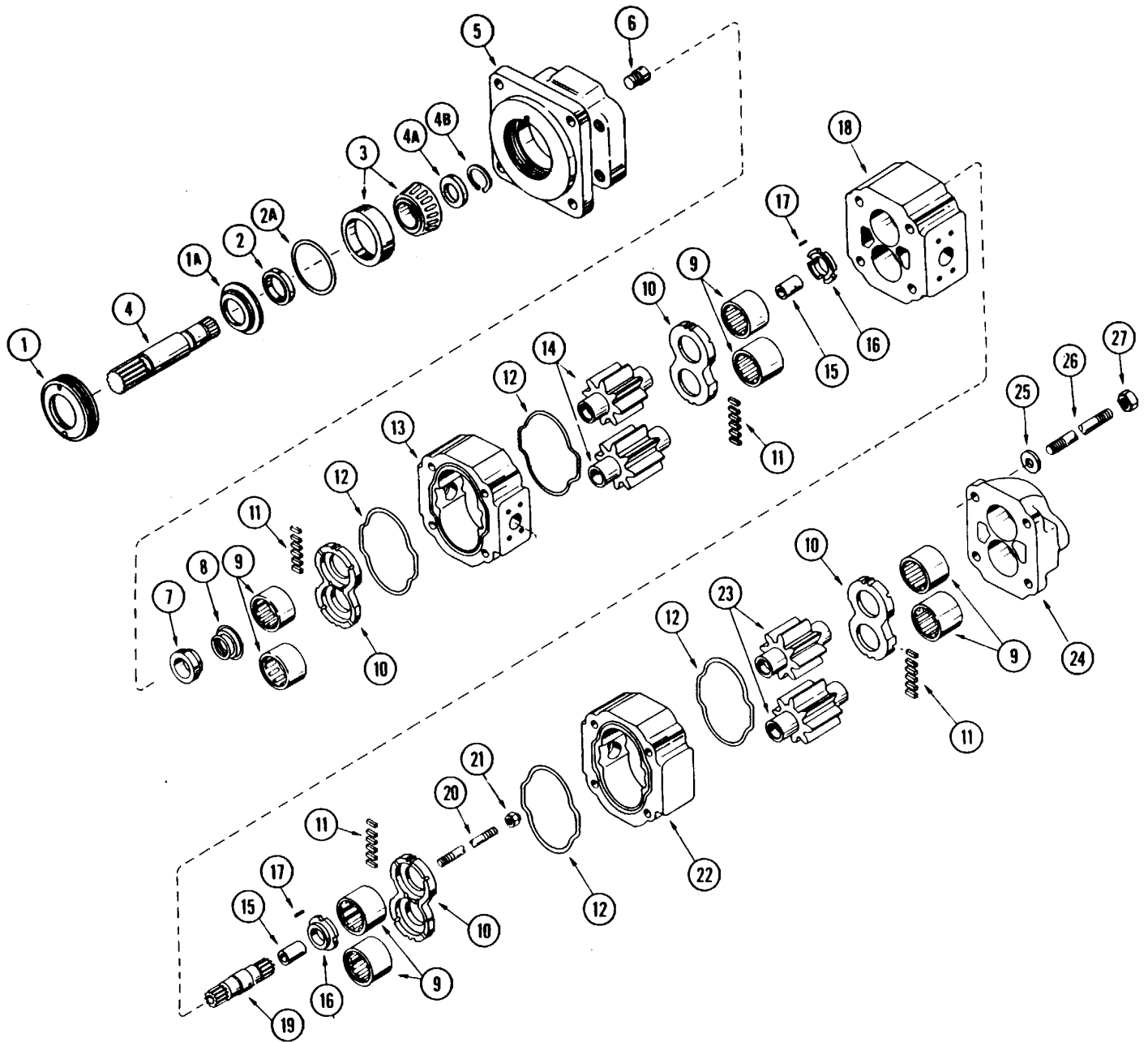

REF. NO.	PART NUMBER	DESCRIPTION	NO. REQ'D
		2 SECTION PUMP	
	7-722-000054	2 Section Pump	
1	9-722-100018	Ring, Retainer -----	1
1A	9-722-100021	Retainer, Seal -----	1
2	9-722-100019	Seal, Double Lip -----	1
2A	9-722-100023	"O" Ring-----	1
3	9-722-100024	Bearing, Tapered -----	1
4	9-722-100020	Shaft, Drive -----	1
4A	9-722-100025	Spar -----	1
4B	9-722-100026	Ring, Retainer -----	1
5	9-722-100022	Cover, Shaft End -----	1
6	9-722-100372	Plug -----	1
7	9-722-100027	Bushing, Shaft-----	1
8	9-722-100028	Spring-----	1
9	9-722-100029	Bearings, Roller-----	8
10	9-722-100031	Plats, Thrust -----	4
11	9-722-100123	Seals, Pocket -----	2 Strips
12	9-722-100030	Seals, Gasket-----	4
13	9-722-100034	Housing, Gar-----	1
14	9-722-100033	Gars, Matched-----	1 Set
15	9-722-100032	Spacer-----	1
15A	9-722-100055	Spar -----	1
16	9-722-100036	Bushings -----	2
17	9-722-100056	Pins, Roll-----	2
18	9-722-100035	Carrier, Bearing -----	1
19	9-722-100037	Shaft, Connecting -----	1
20	9-722-100227	Stud -----	1
21	9-722-100042	Nut, Lock-----	1
22	9-722-100053	Housing, Gar-----	1
23	9-722-100054	Gars, Matched-----	1 Set
24	9-722-100045	Cover, Part End -----	1
25	9-722-100046	Washers -----	4
26	9-722-100228	Studs-----	4
27	9-722-100229	Nuts, Hex -----	4

7-722-000054

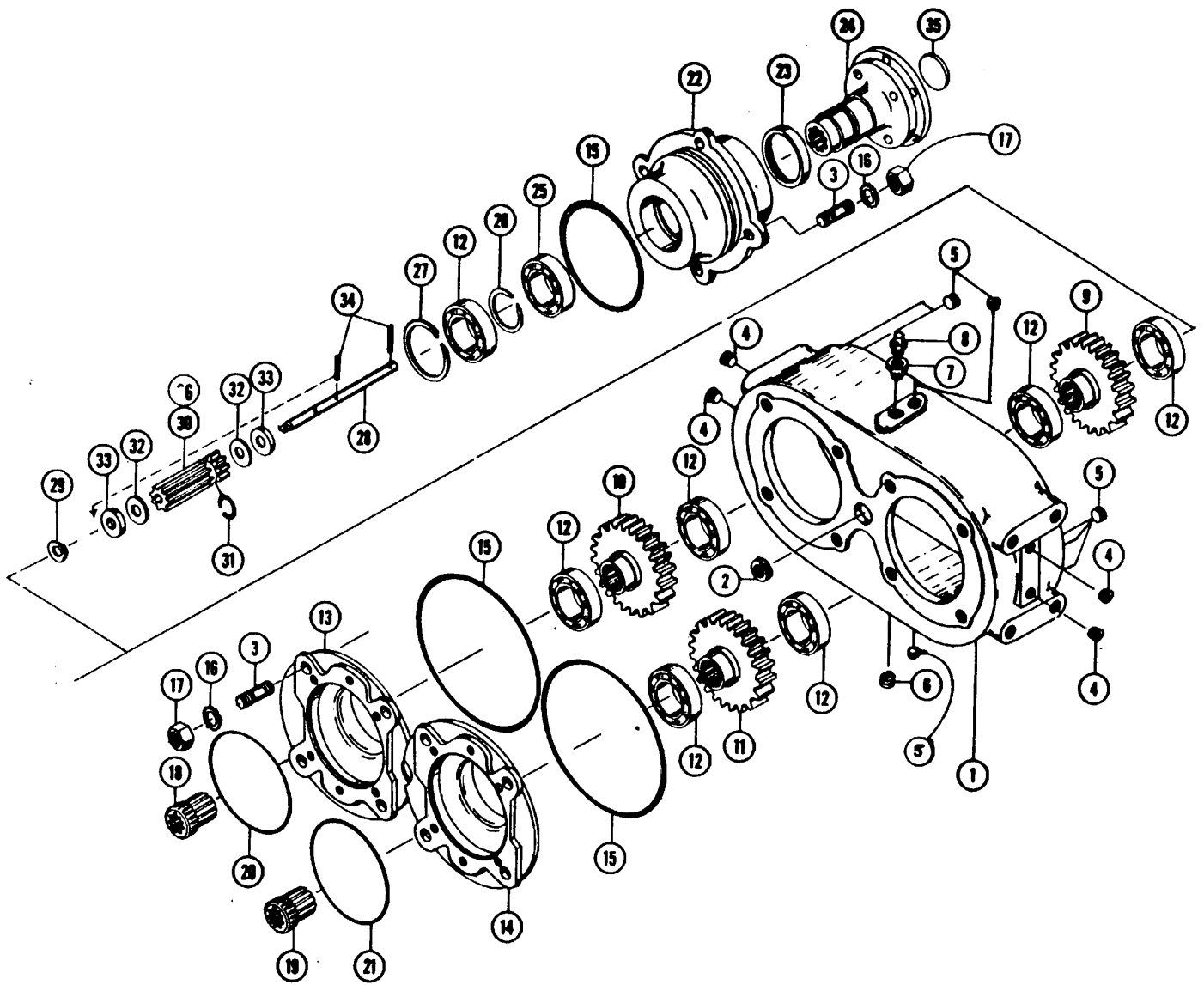

7-722-000085

B-166

REF. NO.	PART NUMBER	DESCRIPTION	NO. REQ'D
	7-722-000085	Pump Drive Assembly	
1	9-722-100535	Housing, Man-----	1
2	9-722-100536	Seal, Oil-----	1
3	9-722-100537	Stud-----	12
4	9-722-100538	Plug-----	4
5	9-722-100539	Plug-----	7
6	9-722-100540	Plug-----	1
7	9-722-100541	Bushing, Reducing-----	1
8	9-722-100542	Breather-----	1
9	9-722-100543	Gar, Pinion-----	1
10	9-722-100544	Gar-----	1
11	9-722-100544	Gar-----	1
12	9-722-100545	Bearing-----	7
13	9-722-100546	Adapter-----	1
14	9-722-100546	Adapter-----	1
15	9-722-100547	Gasket-----	3
16	9-722-100548	Washer, Star-----	12
17	9-722-100549	Nut-----	12
18	9-722-100550	Adapter, Sleeve-----	1
19	9-722-100550	Adapter, Sleeve-----	1
20	9-722-100551	O Ring-----	1
21	9-722-100551	O-Ring-----	1
22	9-722-100552	Adapter, Input-----	1
23	9-722-100553	Seal, Oil-----	1
24	9-722-100554	Flange, Input-----	1
25	9-722-100555	Bearing-----	1
26	9-722-100556	Ring, Snap-----	1
27	9-722-100557	Ring, Snap-----	1
28	9-722-100558	Shaft, Ds Shift-----	1
29	9-722-100559	Ring, Snap-----	1
30	9-722-100560	Connector & Bushing Ass'y. (Includes Item #36)-----	1
31	9-722-100561	Detent, Ring-----	1
32	9-722-100562	Washer, Bronze Thrust-----	2
33	9-722-100563	Washer, Steel Thrust-----	2
34	9-722-100564	Pin, Roll-----	2
35	9-722-100565	Plug, Expansion-----	1
36	9-722-100665	Bushings, Nylon----- (Located Inside #30 Connector)	2

7-722-000085

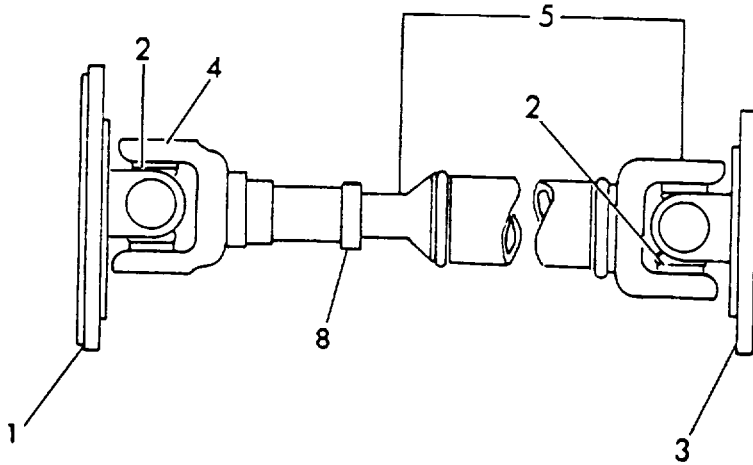

REF. NO.	PART NUMBER	DESCRIPTION	NO. REQ'D
PROPELLER SHAFT ASSEMBLY			
1	7-308-000078	Yoke, Flange-----	1
2	7-069-000182	Journal & Bearings Group-----	2
3	9-364-100253	Yoke, Flange-----	1
4	9-364-100109	Yoke, Slip - Includes Weldment Plug -----	1
5	9-364-100254	Tubing, Spline Plug & Weldment Yoke -----	1
6	9-364-100251	Fitting, Lube - Not Shown -----	1
8	9-364-100252	Dust Cap Group-----	1

7-810-001415

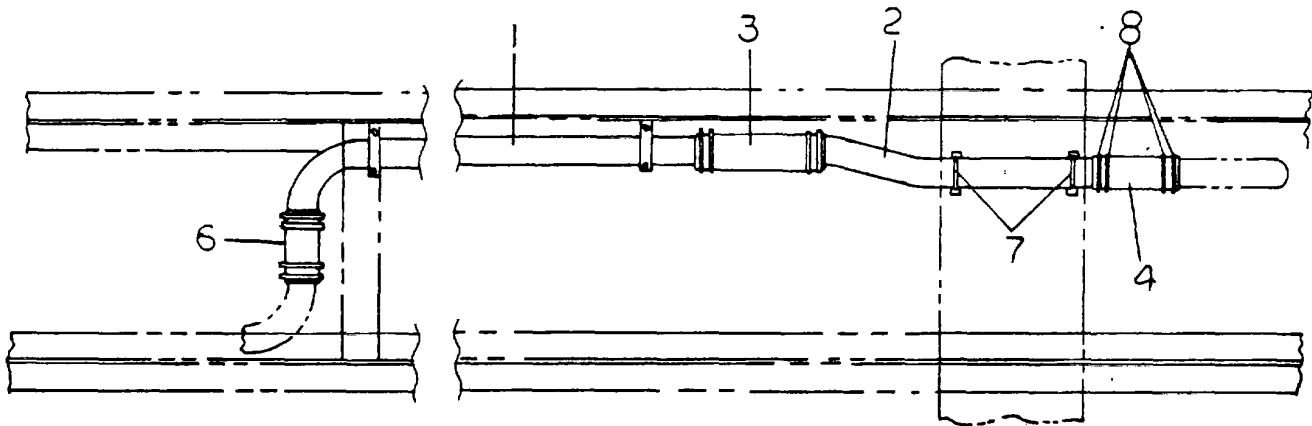

REF. NO.	PART NUMBER	DESCRIPTION	NO. REQ'D
----------	-------------	-------------	-----------

HYDRAULIC SUCTION TUBE INSTALLATION

1	7-910-002037	Tub -----	1
2	7-910-002065	Tub -----	1
3	6-543-000395	Hs, Suction -----	1
4	6-543-000394	Hs, Suction -----	1
6	6-543-000398	Hs, Suction -----	1
7	7-300-000047	Clap, Muffler -----	4
8	7-300-000162	Clap, Hs -----	12

2-147-8-00013 (A)

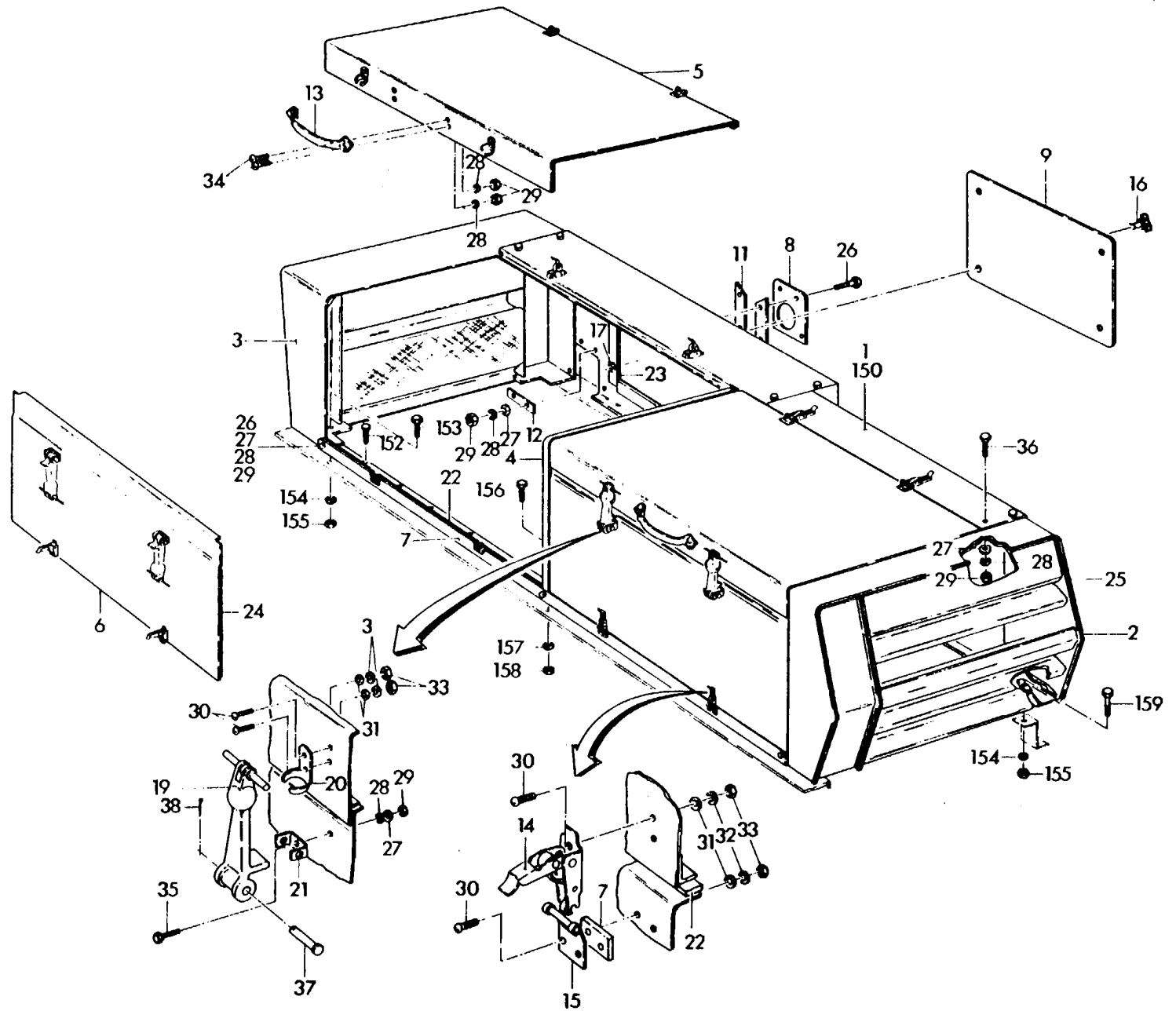

B-170

REF. NO.	PART NUMBER	DESCRIPTION	NO. REQ'D
ENGINE HOOD ASSEMBLY & INSTALLATION			
1	2-147-4-00021	Engine Hood Weldment -----	1
2	2-147-4-00018	Cowl & Grill Weldment-----	1
3	2-147-4-00083	Rear Cowl Weldment-----	1
4	2-147-4-00015	Hood Support Weldment -----	1
5	2-147-4-00020	Engine Hood Door Weldment -----	2
6	2-147-4-00019	Engine Hood Door Weldment -----	2
7	2-147-4-00017	Door Mount Weldment -----	1
8	4-147-8-00023	Plate -----	1
9	4-147-8-00021	Plate -----	1
11	6-671-000089	Pad, Asbestos -----	1
12	6-671-000090	Pad, Asbestos -----	4
13	7-511-000071	Handle .. - -----	2
14	7-300-000092	Clamp, Hinge -----	8
15	7-519-000057	Strike, Hinge -----	8
16	7-429-000008	Wing Head Stud Assembly-----	4
17	7-949-000174	Washer, Retaining-----	4
19	7-539-000049	Hook, Rubber -----	4
20	7-184-000450	Bracket, Hood -----	4
21	7-184-000449	Bracket, Anchor-----	4
22	6-637-001023	Gasket-----	1
23	6-637-000007	Gasket-----	1
24	6-637-011007	Gasket-----	1
25	6-637-005010	Channel, Rubber-----	1
26	MS90725-6	Bolt, Hex Head - 1/4"-20 N.C. x 3/4" Length - Grade 1 -----	7
27	MS27183-11	Flatwasher - 5/16" I.D. x 3/4" O.D. x .065 Thick - Steel -----	22
28	MS35338-44	Lockwasher - 1/4" Medium - Spring Steel -----	30
29	MS51967-2	Nut, Hex - 1/4"-20 N.C. - Grade A -----	30
30	MS35206-264	Screw, Round Head Machine - #10-24 N.C. x 5/8" Length - Grade 1-----	40
31	MS27183-42	Flatwasher - 7/32" I.D. x 1/2" O.D. x .049 Thick - Steel -----	40
32	MS35338-43	Lockwasher - #10 Medium - Spring Steel -----	40
33	MS35649-202	Nut, Hex - #10-24 N.C. - Grade A -----	40
34	MS51957-8	Screw, Stainless Steel Oval Head Machine - 1/4"-20 x 5/8" Length - Grade 4 -----	8
35	MS90725-3	Bolt, Hex Head - 1/4"-20 N.C. x 1/2" Length - Grade 1 -----	4
36	MS90725-8	Bolt, Hex Head - 1/4"-20 N.C. x 1" Length - Grade 1 -----	11
37	7-690-153200	Pin, Clevis - 5/16" Diameter x 2" Length - TL Steel -----	4
38	MS24665-387	Pin, Cotter - 1/8" Diameter x 1" Length - Steel -----	4

2-147-4-00084

REF. NO.	PART NUMBER	DESCRIPTION	NO. REQ'D
ENGINE HOOD ASSEMBLY & INSTALLATION			
150	2-147-4-00085	Engine Hood Assembly -----	1
152	7-790-141053	Screw, Hex Washer Head Self Tapping - 1/4"-20 x 5/8" Length -----	15
153	MS90725-113	Bolt, Hex Head - 1/2"-13 N.C. x 1 1/2" Length - Grade 1-----	6
154	MS35338-48	Lockwasher - 1/2" Medium - Spring Steel-----	7
155	MS51967-14	Nut, Hex - 1/2"-13 N.C. - Grade A-----	7
156	MS90725-62	Bolt, Hex Head - 3/8"-16 N.C. x 1 1/4" Length - Grade 1-----	4
157	MS35338-46	Lockwasher - 3/8" Medium - Spring Steel-----	4
158	MS51967-8	Nut, Hex - 3/8"-16 N.C. - Grade A-----	4
159	MS90725-109	Bolt, Hex Head - 1/2"-13 N.C. x 1" Length - Grade 1 -----	1

2-147-4-00084

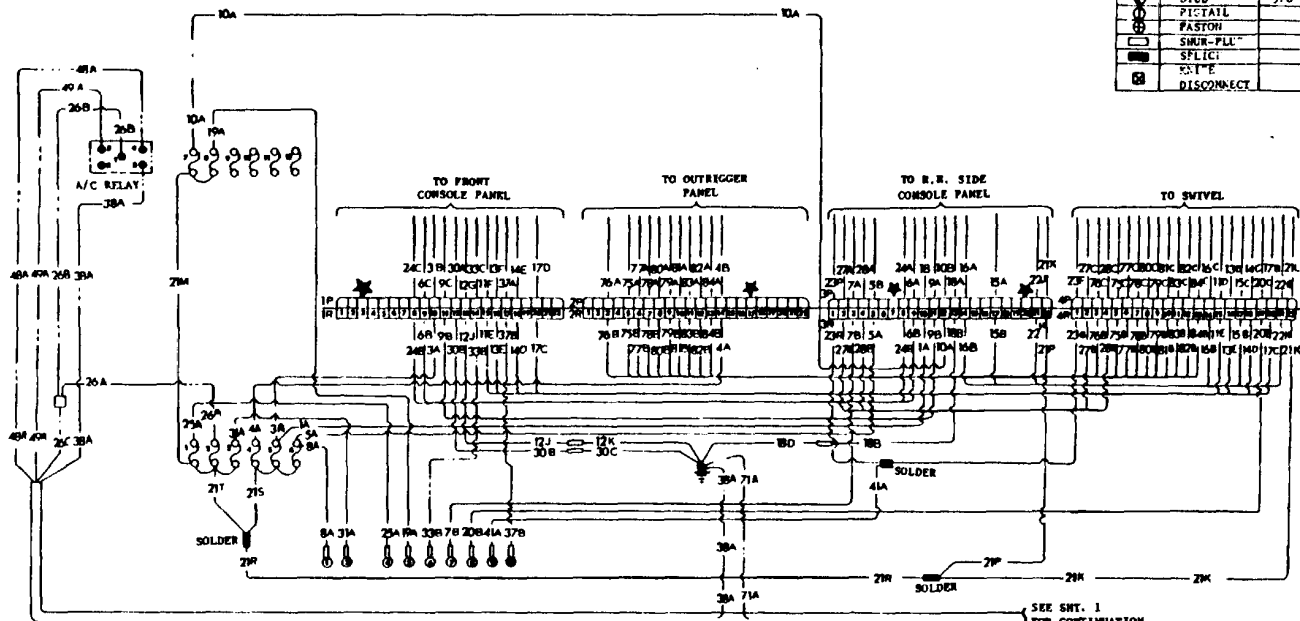

TERMINALS		
SYMBOL	TERMINAL	STUD SIZE
○	STUD	#6
○	STUD	#8
○	STUD	#10
○	STUD	1/4
○	STUD	5/16
○	STUD	3/8
○	PICHTAIL	
○	PASTON	
○	SHUN-PLUG	
○	SPLICE	
○	ENTR	
○	DISCONNECT	

CIRCUITS		
WIRE NO.	COLOR	GAGE
1	BLUE W/BLK STRIPE	14
2	GREEN	14
3	GREEN W/WH STRIPE	14
4	RED	14
5	YELLOW	14
6	TAN W/WH STRIPE	14
7	BLUE	14
8	WHITE W/BLK STRIPE	14
9	TAN W/WH STRIPE	14
10	ORANGE W/WH STRIPE	14
11	PINK	14
12	BLACK	14
13	BROWN	14
14	PURPLE	14
15	WHITE	14
16	GREEN	14
17	GRAY	14
18	BLACK	14
19	TAN	14
20	TAN	14
21	RED	14
22	RED	14
23	ORANGE	14
24	ORANGE	14
25	BROWN W/BLK STRIPE	14
26	RED	14
27	BLACK W/WH STRIPE	14
28	RED W/WH STRIPE	14
29	BLACK	14
30	BLACK	14
31	RED L/BLK STRIPE	14
32	GREEN	14
33	BROWN W/BLK STRIPE	14
34	BLACK	14
35	BLACK	14
36	ORANGE	14
37	RED	14
38	BLACK	14
39	BLACK	14
40	BLUE	14
41	RED W/WH STRIPE	14
42	BLACK	14
43	RED	14
44	GREEN	14
45	RED W/BLK STRIPE	14
46	WHITE W/BLK STRIPE	14
47	YELLOW W/BLK STRIPE	14
48	RED	14
49	ORANGE	14
50	BLUE	14
51	ORANGE W/BLK STRIPE	14
52	GREEN W/BLK STRIPE	14
53	YELLOW W/BLK STRIPE	14
54	TAN W/BLK STRIPE	14
55	WHITE W/BLK STRIPE	14
56	GRAY W/BLK STRIPE	14
57	PURPLE W/BLK STRIPE	14
58	BROWN W/BLK STRIPE	14
59	PINK W/BLK STRIPE	14
60	RED W/BLK STRIPE	14
61	BLACK	14

FUSE AND CONNECTOR PANEL WIRING

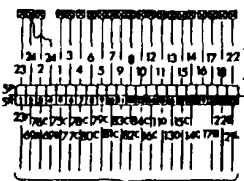

VENDOR'S WIRE NO'S AND CORRESPONDING SLIP RINGS

SEE SHT. 1 OF 3

FUSES

- 1) - 6.0A
- 2) - 30.0A (OPT.)
- 3) - 10.0A (OPT.)
- 4) - 10.0A
- 5) - 6.0A
- 6) - 8.0A
- 7) - 8.0A
- 8) - 6.0A
- 9) - 6.0A (SPARE)
- 10) - 8.0A (SPARE)
- 11) - 10.0A (SPARE)
- 12) - 6.0A (SPARE)

58	BLACK	14
59	WHITE	14
60	BLACK	14
61		
62		
63		
64	BLACK	14
65	BLACK	14
66	BLACK	14
67	BLACK	14
68	BLACK	14
69	BLACK	14

NOTES:

1. WHERE SHUN-PLUGS ARE SHOWN FOR COMPONENT HOOK-UP, THE RECEPTACLE IS TO BE PART OF THE COMPONENT AND THE MALE (BULLET) TO BE ON MATING WIRE.
2. SUPPLIED WITH SPOTLIGHT.
3. ENGINE STOP SWITCH AND WIRE #16 NOT REQUIRED FOR CUMMINS OR CAT. ENGINE
4. IF ANY GAUGE READS DOWN SCALE-REVERSE LEADS.
5. ALL UNUSED WIRES ARE TO BE TAPED AND STORED - BOTH ENDS.
6. ALL FUSE JUMPERS ARE RED AND #12 GA. EXCEPT AS NOTED.
7. TO BOOM ANGLE INDICATOR AND SPOTLIGHT (OPT.).
8. TO ANTI-TWO BLOCK RELAY.
9. TO BLOWER SWITCH (A/C EVAPORATOR) (OPT.).
10. TO DEFROSTER
11. TO SWING HORN BUTTON
12. TO ANTI-TWO BUZZER
13. TO CAB LIGHT
14. TO SWING HORN BUTTON
15. TO HEATER (POWER)
16. TO LIGHT CIRCUIT OF HEATER CONTROL PANEL.

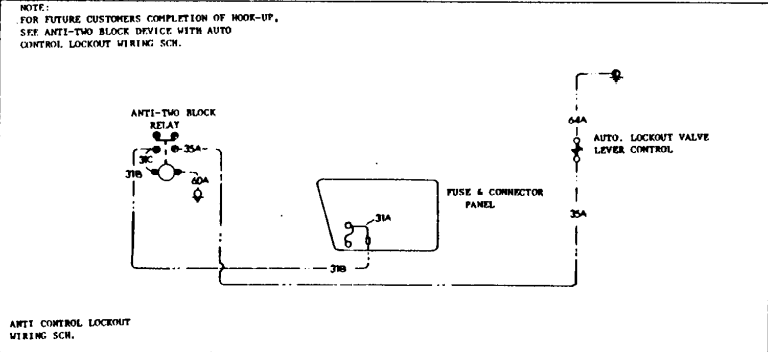
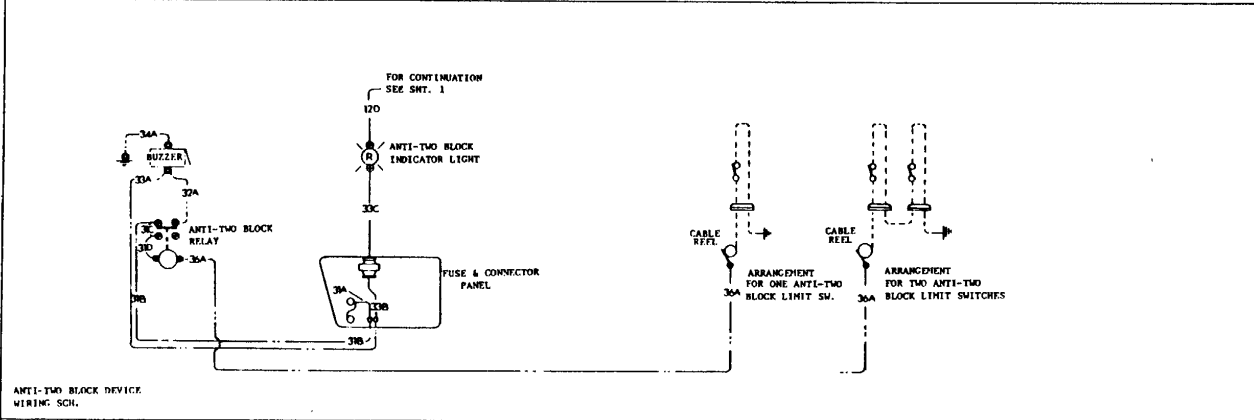
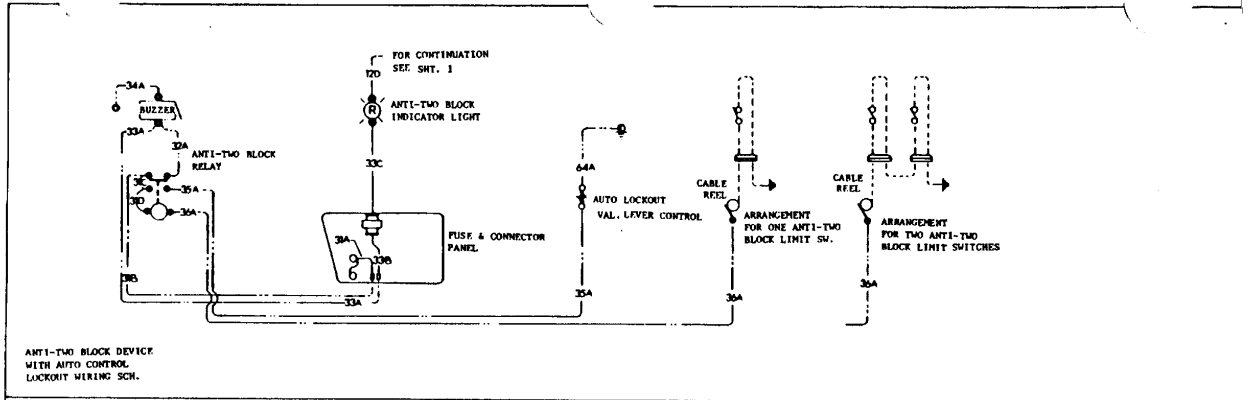

THIS SHEET FOR WIRING OF ANTI-TWO BLOCK AND/OR AUTO CONTROL LOCKOUT ONLY

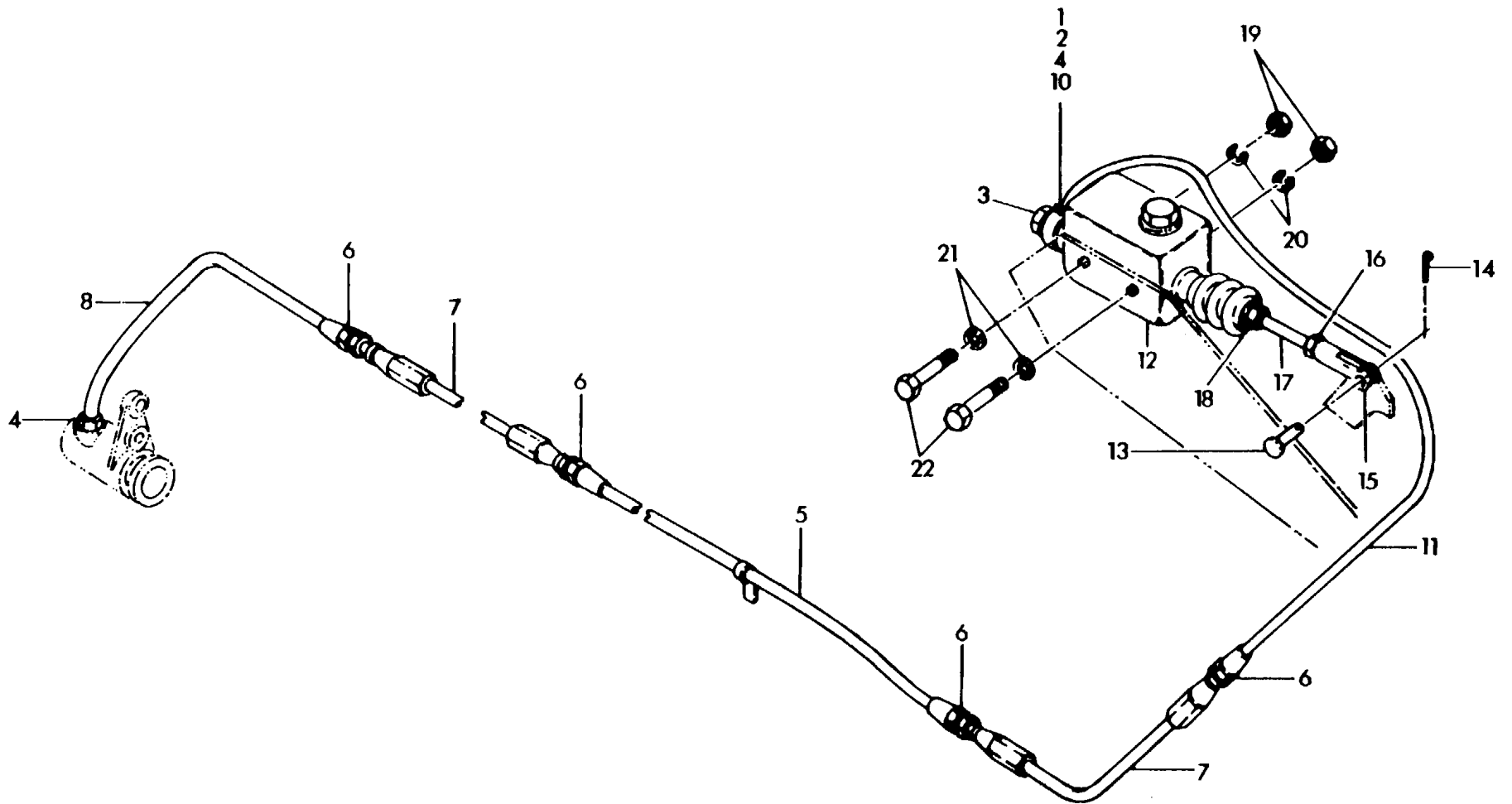

2-130-1-00095

B-176

REF. NO.	PART NUMBER	DESCRIPTION	NO. REQ'D
CLUTCH MASTER CYLINDER & SLAVE CYLINDER HYDRAULIC LINES INSTALLATION			
1	7-794-000076	Gasket	1
2	7-443-000014	Fitting, Swivel	1
3	7-099-000029	Bolt, Connector	1
4	7-659-000015	Nut, Standard.....	2
5	6-910-001129	Tube	1
6	7-659-000049	Nut, Flare	4
7	7-543-000672	Hose	2
8	6-911-040961	Tubing, Copper	1
10	7-794-000077	Gasket.....	1
11	6-911-042721	Tube, Copper	1
12	6-372-001169	Master Cylinder Assembly.....	1
13	MS35810-4	Pin, Clevis - 3/8" Diameter x 1" Length - Steel	1
14	MS24665-300	Pin, Cotter - 3/32" Diameter x 3/4" Length - Steel	1
15	7-308-000001	Yoke	1
16	MS51968-8	Nut, Hex - 3/8"-24 N.F. - Grade A.....	1
17	6-865-162270	Stud	1
18	MS51968-8	Nut, Hex - 3/8"-24 N.F. - Grade A.	1
19	MS51967-8	Nut, Hex - 3/8"-16 N.C. - Grade A.....	2
20	MS35338-46	Lockwasher - 3/8" Medium - Spring Steel.....	2
21	MS27183-15	Flatwasher - 7/16" I.D. x 1" O.D. x .083 Thick - Steel	2
22	MS90725-71	Bolt, Hex Head - 3/8"-16 x 3 1/2" Length - Grade 1	2

2-130-1-00095 (B)

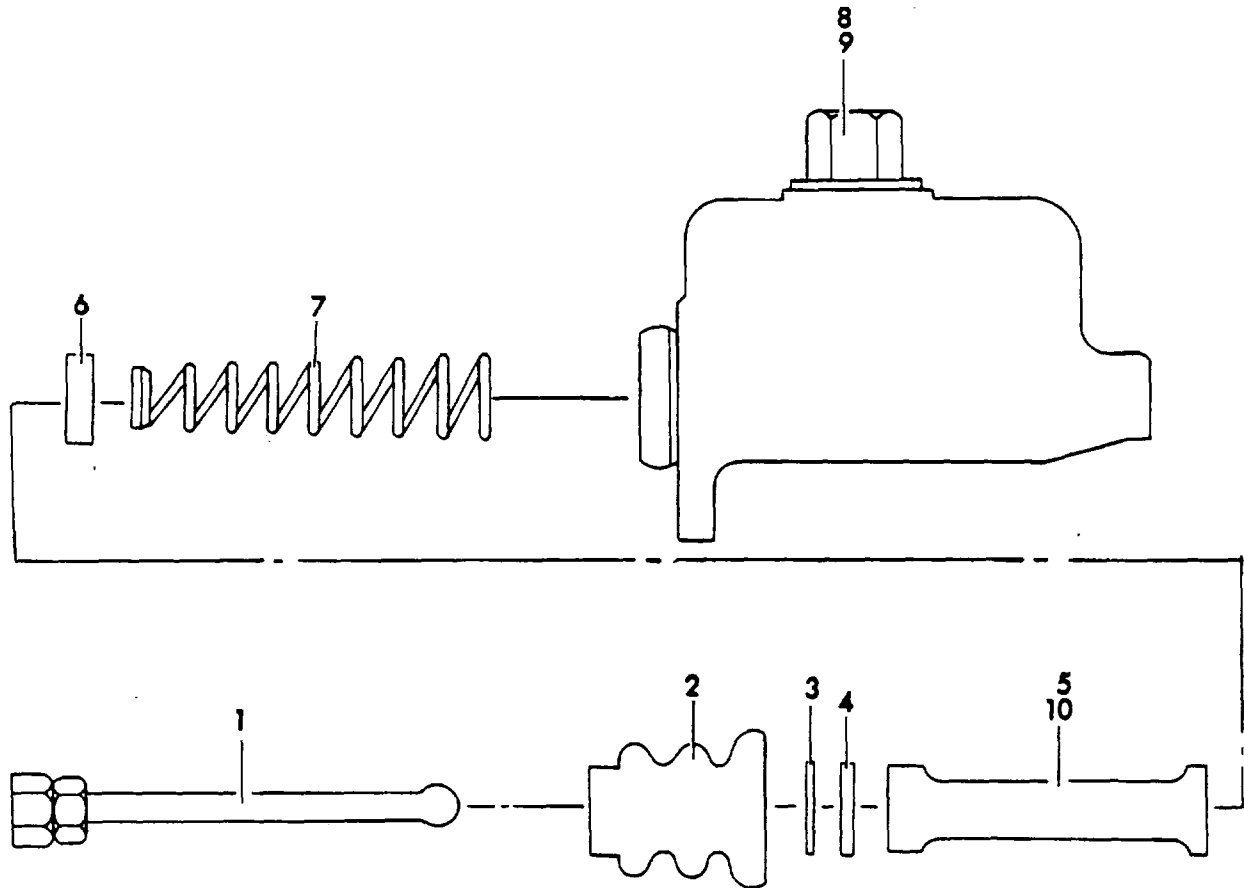

REF. NO.	PART NUMBER	DESCRIPTION	NO. REQ'D
	6-372-001169	Master Cylinder	
1	7-372-100427	Rod, Push Piston -----	1
2	9-372-100426	Boot -----	1
3	9-372-100425	Wire, Lock Ring - 1	
4	9-372-100424	Plate, Stop Piston -----	1
5	9-372-100422	Piston Assembly -----	1
6	9-372-100421	Cup, Primary Piston -----	1
7	9-372-100420	Spring Assembly -----	1
8	9-372-100428	Gasket, Filler Plug -----	1
9	9-372-100429	Plug, Filler Tank -----	1
10	9-372-100423	Cup, Secondary Piston -----	1

6-372-001169

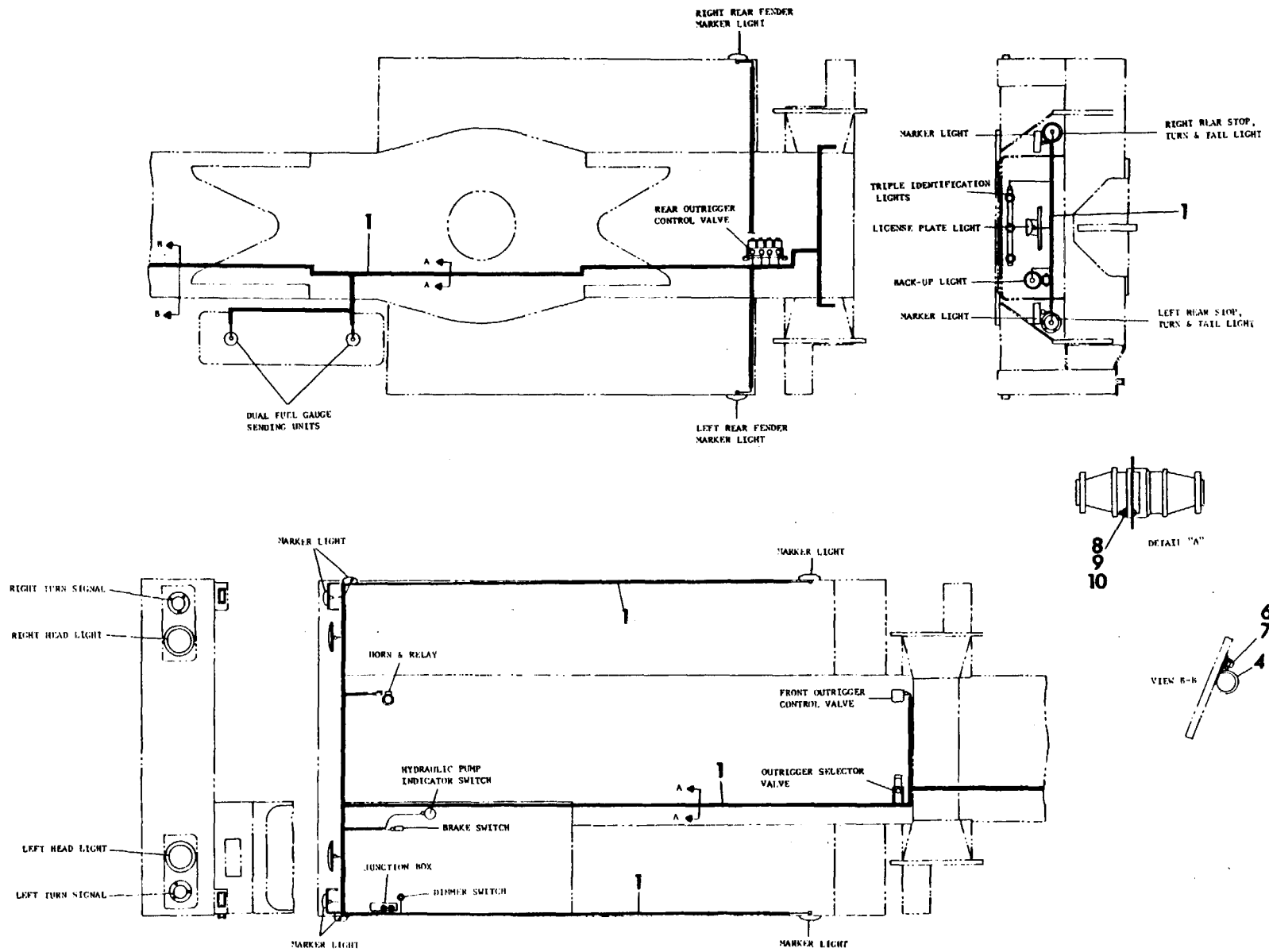

6-978-000481

B-179

REF. NO.	PART NUMBER	DESCRIPTION	NO. REQ'D
WIRING HARNESS INSTALLATION - CARRIER			
1	7-978-000501	Wiring Harness Assembly -----	1
2	7-978-000384	Wiring Harness Assembly - Outrigger	
		Control Valve - Not Shown -----	2
3	7-978-000383	Wiring Harness Assembly - Outrigger	
		Selector Valve - Not Shown -----	1
4	7-300-000104	Clamp -----	40
6	MS35338-44	Lockwasher 1/4" Medium - Spring Steel -----	42
7	MS35649-2252	Nut, Hex 1/4"-20 U.N.C. - Grade A -----	42
8	MS35206-230	Screw, Round Head Machine #6-32 U.N.C. x 1/2" Length - Grade 1 -----	8
9	MS35649-262	Nut, Hex #6-32 U.N.C. - Grade A -----	8
10	MS35338-41	Lockwasher #6 Medium - Spring Steel -----	8

6-978-000481

B-180

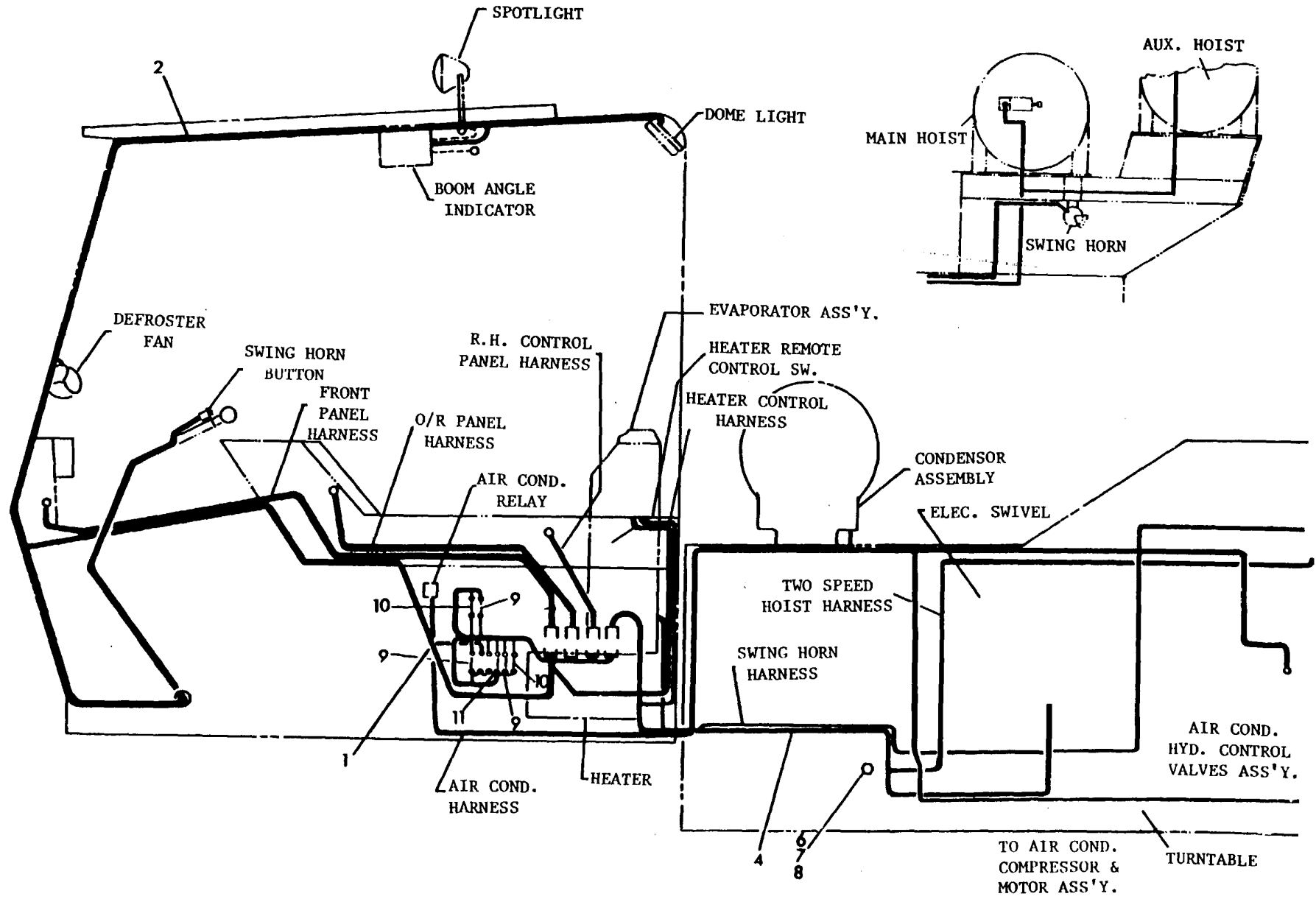

6-978-000446

B-181

REF. NO.	PART NUMBER	DESCRIPTION	NO. REQ'D
WIRING HARNESS INSTALLATION - SUPERSTRUCTURE			
1		Fuse & Connector Panel Assembly - See Separate Parts List -----	1
2	7-978-000326	Wiring Harness Assembly Cab Miscellaneous-----	1
3	7-978-000379	Wiring Harness Assembly - Heater -----	1
4	7-978-000322	Wiring Harness Assembly - Cab to Swivel -----	1
5	MS35206-226	Screw, Round Head Machine #6-32 U.N.C. x 1/4" Length - Grade 1 -----	4
6	7-866-142140	Stud, Weld -----	1
7	MS35338-44	Lockwasher 1/4" Medium - Spring Steel -----	1
8	MS51967-2	Nut, Hex 1/4"-20 U.N.C. - Grade A -----	1
9	7-482-000020	Fuse -----	3
10	7-482-000018	Fuse -----	2
11	7-482-000019	Fuse -----	1

6-978-000446 (A)

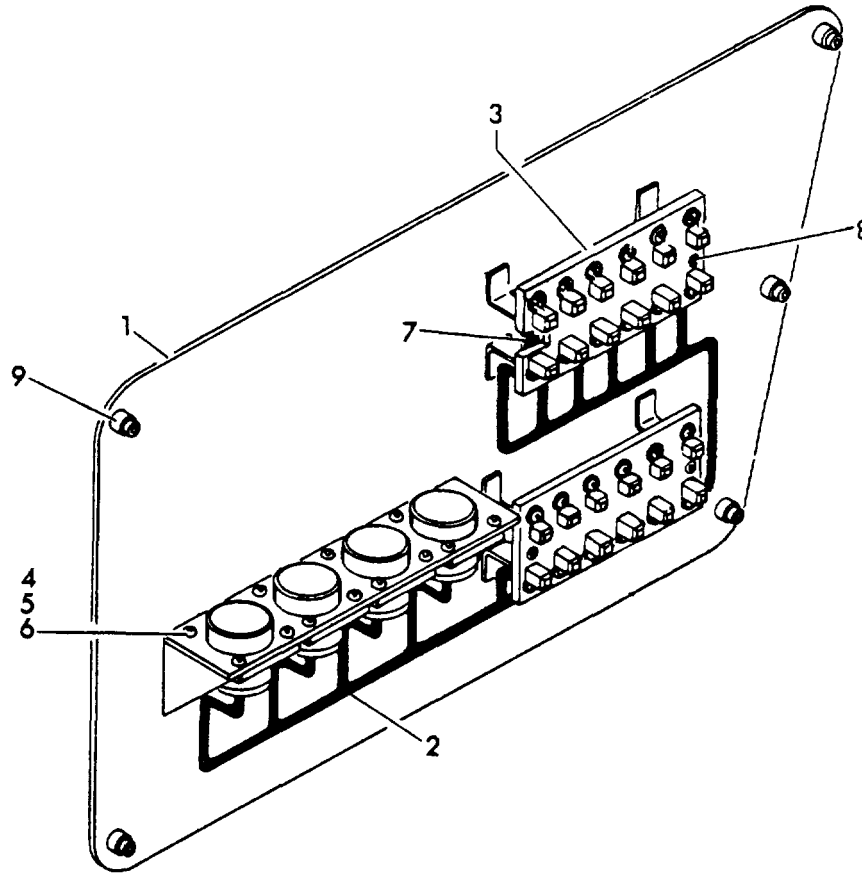

REF. NO.	PART NUMBER	DESCRIPTION	NO. REQ'D
FUSE & CONNECTOR PANEL ASSEMBLY			
	2-120-4-00007	Fuse & Connector Panel Assembly	
1	2-120-4-00009	Fuse & Connector Panel Weldment r-----	1
2	7-978-000344	Wiring Harness Assembly Junction Box -----	1
3	7-086-000370	Fuse Block - 6 Pole -----	2
4	MS35206-230	Screw, Round Head Machine - #6 -32 x 1/2" Lg. - Grade 1-----	16
5	MS35649-262	Nut, Hex - #6 -32 U.N.C. - Grade A -----	16
6	MS35338-41	Lockwasher - 16 Medium - Spring Steel -----	16
7	6-637-012001	Tuff - Pack-----	1
8		Screw, Countersink Head - #8 - 32 x 1/2" Lg.-	4
9	7-429-000013	Fastener-----	5

2-120-4-00007 (A)

**MANUFACTURER TO VENDOR
CROSS REFERENCE INDEX**

**MANUFACTURER TO VENDOR
CROSS REFERENCE INDEX**

<u>PART NUMBER</u>	<u>VENDOR PART NUMBER</u>	<u>VENDOR CODE</u>	<u>QTY PER VEHICLE</u>	<u>PART NUMBER</u>	<u>VENDOR PART NUMBER</u>	<u>VENDOR CODE</u>	<u>QTY PER VEHICLE</u>
SKA771880	56A	81493		7099000029	FG-673	63477	
SKA771913	HS-403	36581		7099000075	AY-1402K-1	13829	
SKA772415	W20-1P	77146		7099000076	AY-1402K-2	13829	
700900007	HDR330002	54220		7099000085	AX-1402K-1	13829	
7013000041	839-WM	30327		7099000087	AX-1402K-3	13829	
7013000125	720-F50-1/2X1/2	30327		7099000154	6543	72653	
7013000147	24IFD90	72807		7099000159	CL-1-SHS	99862	
7013000165	P01-8164	18265		7099000215	14016	52304	
7013000176	667-SC	57733		7099000274	T-5544	99062	
7013000195	236701	06853		7099000275	09738-01	99062	
7013000204	P10-5612	18265		7099000276	T-2306	99062	
7013000225	H1-2424	99103		7099000277	T-5492	99062	
7013000267	45000-7	28158		7176000214	S-47060	92878	
7013000284	2-47650	92878		7184000106	205293	06850	
7013000292	16F-16JUFS	72807		7184000189	221399	06850	
7025000005	9000130	16764		7184000449	227-A-80	92878	
7025000015	9000514	16764		7184000450	028-561	92878	
7025000029	861-A	27647		7184000463	12158	79146	
7025000051	465594	77640		7184000629	6707	27647	
7029000009	1117481	16764		7184000629	BA3991-1	98440	
7033000041	LE721139-20	07988		7184000630	B9-1926	98440	
7033000081	LE721125-A1	07988		7188000025	00-1044-0011	22075	
7033000092	436852-33	77640		7199000011	9933P	75174	
7033000125	LE721139-22	07988		7199001115	T-5493	99062	
7033000178	T-7635	99062		7242000004	SS-48175	90763	
7033000179	T-2293	99062		7242000005	SS-51142	90763	
7033000180	T-5485	99062		7242000007	SS-48165	90763	
7033000181	T-5486	99062		7242000009	SS-51043	90763	
7049000117	FL931-RDAX1	78500		7242000010	SS-50685-K2215	90763	
7049000118	FL931-RDAX2	78500		7242000012	SS-48152-K2215	90763	
7049000209	FL931-RDAX1	78500		7242000015	SS-48152-K2215	90763	
7049000210	FL931-RDAX2	78500		7242000017	XX-51286	90763	
7049000297	SHD-RDA-X-72	78500		7242000019	SS-51034	90763	
7049000298	SHR-RDA-X-62	78500		7242000020	SS-48132	90763	
7056000008	AAH-00-0350	18265		7242000022	SS-48166	90763	
7056000061	SB14F122	22337		7246000183	538-IV/PS-2-91 IN	04638	
7061000034	B8020LWD	73842		7246000279	8366	79470	
7064000017	1980337	16764		7246000332	15253403	92867	
7067000010	DA-30247-9	28158		7246000436	X-154-99	01976	
7069000001	LJ1 1/2 Z	08654		7246000506	500-P	80406	
7069000031	T-301-W	60038		7258000063	049910	90005	
7069000041	30355C	43766		7258000251	GAH00-0606	18265	
7069000107	303KDD	21335		7258000303	RC400	01652	
7069000108	Z993L08	43334		7258000356	WP-575	73972	
7069000109	L217810 & L217849	60038		7258000409	6147L220	18265	
7069000110	JHM516810&JHM516849	04609		7270000378	8696	52304	
7069000111	NCS1616	27737		7300000006	GS28-30	76599	
7069000129	210121-1-X	51205		7300000010	81000191	92867	
7069000137	NB-4012	60380		7300000011	81000108	92867	
7069000138	RA43268	60380		7300000013	GS-10	76599	
7069000145	B-8812	60380		7300000016	GS-44	76599	
7069000146	G-3140-B	60380		7300000019	SOS	03010	
7069000161	TWD-2435	27737		7300000020	GS-35	76599	
7069000162	NTA2435	60380		7300000035	GS-36	76599	
7069000163	1000909506	43334		7300000036	MC-312	72741	
7069000171	T-63 TYPE TTSP	60038		7300000040	GS-8	76599	
7069000173	GRA-1 1/4	21335		7300000047	P20-0586	18265	
7069000175	QQ-P-416	93393		7300000056	590-S	93736	
7069000182	CP35R	78500		7300000088	GS-104	76599	
7069000183	JUM714149	60038		7300000089	254	94431	
7069000243	M2 25-48E2	32828		7300000092	ZLA1096-13	07538	
7069000268	6461A	78500		7300000098	232821	06853	
7069000269	5555	78500		730000100	232823	06853	
7069000273	6168	52304		730000101	232824	06853	
7072000001	118-B-0026-2	04638		730000102	232825	06853	
7074000066	5133601	72582		730000104	232827	06853	
7083000008	18802	70412		730000143	206138-1	00779	
7086000370	3833-6	71400		730000145	722	73972	

MANUFACTURER TO VENDOR CROSS REFERENCE INDEX

		QTY				QTY	
VENDOR		VENDOR		VENDOR		VENDOR	
PART NUMBER	PART NUMBER	CODE	PER VEHICLE	PART NUMBER	PART NUMBER	CODE	PER VEHICLE
7300000160	300-179	53203		7445060443	848FS00604	30327	
7300000161	W858	73972		7445060604	60UA0606	30327	
7300000162	5321C-509-5	14242		7445060605	60UC0606	30327	
7300000167	GS-20	76599		7445060609	60TA0606	30327	
7300000172	102202	76599		7445060614	60VJ0606	30327	
7300000190	C0-2111	75272		7445060619	848FS0606	30327	
7300000203	2425891	72582		7445060655	25VJ0606	30327	
7300000204	RMT-308	66295		7445060801	60SA0608	30327	
7304000013	POO-4076	18265		7445060804	60UA0608	30327	
7304000024	FHG14-0055	18265		7445060817	24SG0608	30327	
7308000001	9419D	19220		7445060819	848FS0608	30327	
7308000013	9419H	19220		7445080404	60UA0804	30327	
7308000014	2708-3A	19220		7445080601	60SA0806	30327	
7308000047	A45720	41625		7445080604	60UA0806	30327	
7308000056	81003678	92867		7445080608	60UB0806	30327	
7308000077	A42212	41625		7445080617	24SG0806	30327	
7308000083	A35840	41625		7445080801	60SA0808	30327	
7308000084	82NYS40-42	78500		7445080802	60SG0808	30327	
7312000026	SP-5301	78500		7445080804	60UA0808	30327	
7312000027	SP-3254	78500		7445080808	60UB0808	30327	
7312000032	SP-5318-AF-SJ	78500		7445080809	60TA0808	30327	
7312000039	SP-2160-AF-SJ	78500		7445080812	60VC0608	30327	
7316000007	14-2 DPS	36479		7445080849	24SA0808	30327	
7324000053	47023	92878		7445080856	25WJ0808	30327	
7326000015	UC34376	77640		7445081201	60SA0812	30327	
7345001703	324225	00779		7445081204	60UA0812	30327	
7345001831	FP-5336-F	14726		7445100611	60TB1006	30327	
7348000110	896717	33525		7445100845	60TB1008	30327	
7352000027	SRC-10	52304		7445100845	349-FS01008	30327	
7352000053	02032-1/2NPT	16476		7445101211	60TB1012	30327	
7352000054	02505-1-1/8NPT	16476		7445101443	S48FS01014	30327	
7352000057	02381-03	16476		7445120811	60TB1208	30327	
7352000069	HDR330001	54220		7445120817	24SG1208	30327	
7364000021	59uc-12x12x12	30327		7445121043	848FS01210	30327	
7364000034	68x4	79470		7445121201	60SA1212	30327	
7364000294	250x3	79470		7445121204	60UA1212	30327	
7364000425	129-B	30327		7445202031	855-BH-FS2020	30327	
7364000515	954-05-4309	78500		7445242019	848FS2420	30327	
7364000641	268-P	30327		7446040207	469-F0402	88220	
7364000702	955-64-44388	78500		7446040404	466-F0404	88220	
7364000703	955-64-44389	78500		7446040406	468-F0404	88220	
7364000709	955-64-43376	78500		7446040407	469-F0404	88220	
7372000303	279414	06850		7446060206	468-F602	88220	
7372000457	FD-48907	63477		7446060404	466-F0604	88220	
7372000872	2972	94431		7446060407	469-F0604	88220	
7372001141	03-020-145-(702A2)	92865		7446060414	477-F0604	88220	
7406000029	69X4	79470		7446060601	462-F0606	88220	
7406000101	P10-5535	18265		7446060606	468-F0606	88220	
7406000169	402X3	79470		7446060606	468-F0606	88220	
7406000172	2085-12-85	00624		7446060807	469-F0608	88220	
7406000180	W3400X4	79470		7446080406	468-F0804	88220	
7406000243	3400X4X2	79470		7446080407	469-F0804	88220	
7406000287	269-P	30327		7446080635	4-88-LB0806	88220	
7425000001	F-102	46522		7446080640	4-94-LB0806	88220	
7429000008	91S2-10W	77521		7446080802	464-F0808	88220	
7429000013	84-50-080-20	94222		7446080806	468-F0808	88220	
7440000300	5300	32461		7446080807	469-F0808	88220	
7443000014	FC-2678	63477		7446081206	468-F0812	88220	
7443000059	61UA-04X04	30327		7446100414	477-F1004	88220	
7445020204	60UA0202	30327		7446100635	4-88-LB1006	88220	
7445020205	60UC0202	30327		7446100806	468-F1008	88220	
7445020249	24SA0202	30327		7446100807	469-F1008	88220	
7445020401	60SA0204	30327		7446100809	470-F1008	88220	
7445020402	60SG0204	30327		7446100811	472-F1008	88220	
7445020404	60UA0204	30327		7446101002	464-F1010	88220	
7445040404	E-1328-6QUAQA	30327		7446101206	468-F1012	88220	
7445040405	60UC0404	30327		7450000016	24SF	72807	
7445040409	60TA0404	30327		7450000049	213042	06853	
7445040411	60TB0404	30327		7482000005	SFE-20AMP	71400	
7445040414	60VJ0404	30327		7482000018	AGC-8AMP	71400	
7445040449	24SA0404	30327		7482000019	AGC10AMP	71400	
7445040601	60SA0406	30327		7482000020	AGC-6AMP	71400	
7445060401	60SA0604	30327		7486000123	811535	57733	
7445060419	848FS0604	30327		7486000225	24	82084	
7445060420	849FS0604	30327		7486000257	235758	06850	

MANUFACTURER TO VENDOR CROSS REFERENCE INDEX

PART NUMBER	VENDOR PART NUMBER	VENDOR CODE	QTY PER VEHICLE	PART NUMBER	VENDOR PART NUMBER	VENDOR CODE	QTY PER VEHICLE
7486000261	735-1	51731		7543000685	4104	24161	
7486000266	275083	06853		7543000692	86	72807	
7486000479	550-JS	57733		7544700690	20SW	72807	
7486000478	455-BF	57733		7544800690	24SW	72907	
7486000486	470-BF	57733		7545101820	4C-4MS-4MS-18	72807	
7486000487	465-DZ	57733		7545206020	6C-6MS-6MS-60	72807	
7486000488	460-BD	57733		7545207220	6C-6MS-6MS-72	72807	
7486000494	06103-1	16476		7545210820	6C-6MS-108	72807	
7486000495	06106-1	16476		7545212020	6C-6MS-6MS-120	72807	
7486000496	06104-1	16476		7545303620	8C-8MS-8MS-36	72807	
7486000497	06101-1	16476		7545306020	8C-8MS-8MS-60	72807	
7486000499	56288-1	16476		7545308420	8C-8MS-8MS-84	72807	
7486000507	139112	61349		7545309620	8C-8MS-8MS-96	72807	
7486000628	550-5	97576		7545310820	8C-8MS-8MS-108	72807	
7486000638	775-001	51731		7545313220	8C-8MS-8MS-132	72807	
7486000684	5092-10	51731		7545338420	8C-8MS-8MS-394	72807	
7486000754	330003	54220		7545501820	12C-12MS-12MS-18	72807	
7490000037	TE70502	77640		7545501880	564-12MS-12MS-19	72807	
7502000003	277192	77640		7545503020	12C-12MS-12MS-30	72807	
7506000002	230	70485		7545504280	12564-12MS-12MS-42	72807	
7506000003	203	70485		7545504820	12C-12MS-12MS-48	72807	
7506000006	2903	70485		7545504880	12564-12MS-12MS-40	72807	
7506000008	2570	70485		7545509620	12C-12MS-96	72807	
7506000014	54-G	70485		7545540880	12564-12MS-12MS-108	72807	
7506000018	2426	70485		7545512080	12564-12MS-12MS-120	72807	
7506000020	2761	70485		7545603680	16564-16MS-16MS-36	72807	
7511000003	111	80813		7545604280	16564-16MS-16MS-42	72807	
7511000040	11X-A-0031	04638		7545616880	16S64-16MS-14FTCC4	72807	
7511000058	V1526K-6	13827		7545618080	564-16MS-16MS-180	72807	
7511000071	752009	57733		7576000007	5-4055	75535	
7511000093	269	80813		7576000017	KT721040	07988	
7515000015	781-12V-D	46522		7576000066	12578-25-M027WC	07988	
7515000021	UH-49-8	92878		7576000069	42591-001	71044	
7519000057	ZYA-1012-13	07538		7576000085	SSCO #53	57733	
7531000046	85531-50	70412		7576000295	11170-01	99062	
7539000013	3220-5 TON	75535		7576000309	1-49390	92878	
7539000049	68D842	74687		7576000320	KT12562	07988	
7542001303	FG1016EEE0130	00624		7576000321	NZ12564	07988	
7542001601	FG1016AEA0160	00624		7581000004	GE67	36618	
7542001803	FG1016EEE0180	00624		7581000013	862-2301	75175	
7542002401	FG1016AEA0240	00624		7581000036	503-2601	75175	
7542002701	FG1016AEA0270	00624		7581000052	GE53	36618	
7542003003	FG1016EEE0300	00624		7581000068	766-2655	75175	
7542003603	FG1016EEE0360	00624		7581000070	766-2101	73331	
7542004603	FG1016EEE0460	00624		7581000070	1055-48	73331	
7542007003	FG1016EEE0700	00624		7581000072	C39FL-A12	20984	
7542008403	FG1016EEE0840	00624		7581000159	62021	81834	
7542009603	FG1016EEE0960	00624		7581000161	46303	81834	
7542010803	FG1016EEE1080	00624		7581000162	46302	81834	
7542018001	FG1016AEA1800	00624		7581000165	1815	36618	
7542102405	FG1016GGG0240	00624		7581000166	5200-222-326(12V)	71744	
7542103005	FG1016GGG0300	00624		7581000167	5200-222-326(12V)	71744	
7542107604	FG1016EGE0760	00624		7581000168	5200-222-326(12V)	71744	
7542109004	FG1016EGE0900	00624		7585000049	5690-50	19220	
7542201811	FG1016GHG0180	00624		7585000099	320048913	19220	
7542203411	FG1016GHG0340	00624		7593000018	C6100-C27-718	92867	
7542203611	FG1016GHG0360	00624		7593000089	5164318	72582	
7542204811	FG1016GHG0480	00624		7593000095	A-219	52304	
7542205811	FG1016GHG0580	00624		7601000134	452207	77640	
7542208811	FG1016GHG0880	00624		7601000014	81000131	92867	
7542211611	FG1016GHG1160	00624		7601000052	40917	94431	
7542221211	FG1016GHG2120	00624		7601000054	41200	94431	
7542301806	FG1016HJH0180	00624		7601000071	41600	94431	
7542302406	FG1016HJH0240	00624		7601000078	41874	94431	
7542303606	FG1016HJH0360	00624		7632000041	101-1077-007	96151	
7542310806	FG1016HJH1080	00624		7638000025	J-7165	76005	
7542312606	FG1016HJH1260	00624		7638000051	J-7153-1	76005	
7542406015	FG1122HKK0600	00624		7638000052	J-8006-6	76005	
7542424015	FG1122HKK2400	00624		7638000056	J-6424-1	76005	
7542501809	FG1016MMM0180	00624		7638000092	J-4624-27	76005	
7542504807	FG1016KMK0480	00624		7642000045	WTM10-0066	18265	
7543000078	4791	24161		7649000004	E006	70847	
7543000126	20A028	24161		7649000005	E034	70847	
7543000369	VF-133 2"X2 1/4	24161		7649000030	E038	70847	
7543000629	2807	00624		7649000043	1KE08N-108	79470	
7543000672	4HBR-4M2B	72807		7659000015	100-4	79470	
7543000674	51006	52304		7659000049	1110X4	79470	

MANUFACTURER TO VENDOR CROSS REFERENCE INDEX

PART NUMBER	VENDOR PART NUMBER	VENDOR CODE	QTY PER VEHICLE	PART NUMBER	VENDOR PART NUMBER	VENDOR CODE	QTY PER VEHICLE
7659000053	31FKF-1011	56878		7755444609	8-444-N300-90	93259	
7659000081	TAN15	60038		7755445000	2-445-N674-70	93259	
7659000145	T-5497	99062		7755901000	3-901-N674-70	93259	
7659000146	T-1704	99062		7755912000	3-912-N674-70	93259	
7659000147	T-5435	99062		7755920000	3-920-N674-70	93259	
7660261630	23TGA	08928		7768000310	DA-30359-14-A	28158	
7660341630	23TWAU2/2	08928		7772000057	CYR-1 3/4	11363	
7671000057	115-A-A-613	22075		7772000101	T-2106	99062	
7679000247	49102	92878		7794000006	501-099	05262	
7683000011	WM-453B	11331		7794000007	7587-1750	81168	
7689000002	516-19PTL	50620		7794000026	001-100	05262	
7689000036	316CP	99037		7794000027	K1250	93259	
7689000044	345L	50620		7794000076	FC-603	63477	
7689000053	180CP	99037		7794000077	FC-6021	63477	
7689000100	ECO 3/8-42 5/3-8	09094		7794000097	592-A	60038	
7689000120	716-11CPC	50620		7794000145	38692	80201	
7689000172	58H	50620		7794000147	CR34974	80201	
7705006341	08065-01	99062		7794000148	46200	80201	
7709000021	SS48155	90763		7794000160	001-255	05262	
7709000028	721-FSO-1/4	88220		7794000180	001-293	05262	
7709000034	SS-48192	90763		7794000185	572	60038	
7709000035	SS50727	90763		7794000246	P01-8188	18265	
7709000038	721-FSO-1/2	88220		7794000272	ULM7-14110	60038	
7709000072	4062061	36540		7794000274	37504750-625-B	93259	
7709000077	206612-1	00779		7794000275	K4750	93259	
7718000100	5-18	75535		7794000288	236170	06853	
7718000216	5100633	72582		7794000411	WP178	73972	
7722000029	MHAG27	46522		7794000429	A1205-M-1399	78500	
7722000054	P25x178B1RZ17-7-GV-AB101-1	13829		7798000022	42065-1	71044	
7722000085	28104A	96105		7798000027	125216	09704	
7726000017	221-310	07176		7798000039	10161-01	99062	
7726000061	21-3498	92857		7810000866	SH721205-A	07988	
7750000015	HR-110	19239		7810001415	922-044-1379	78500	
7753000056	5115-75	19239		7814000120	C20-1P	79146	
7753000113	112-33400-173-0060A	72902		7822000020	BE-14685	28158	
7752000116	112-43300-173	72902		7826000001	5421(040329)1/2	75535	
7753000136	7587-4500	81138		7826000016	32796	94431	
7753000156	5100-250	79136		7826000026	66257-1	00779	
7753000161	7587-6000	81168		7826000027	66578-1	00779	
7753000170	5100-550	79136		7834000012	G-30	92830	
7753000230	N5000-93	79136		7834000015	68-422	18242	
7753000277	124-44400-173-0060-A	72902		7834000020	7RW-7523	23040	
7753000337	R8020LW	73842		7834000027	LC-067-09	84830	
7753000354	717404	80201		7834000064	LC-055J-L	84830	
7753000363	5100-850	93259		7834000112	LE-055F-1	84830	
7753000389	RC850-24GR1	93259		7834000122	T-3086	99062	
7753000415	124-42900-173-0060-A	93259		7834000128	4425	52304	
7754000021	A-010	04962		7845000003	20-324	53203	
7755014000	2-014-N674-70	93259		7846000033	1548	79470	
7755022000	2-022-N674-70	93259		7850000046	71294	70903	
7755114000	2-114-N674-70	93259		7850000064	TY-25-M	59730	
7755125000	2-125-N674-70	93259		7850000102	TY-27M	59730	
7755126609	8-126-N300-90	93259		7850000112	3057-13	98440	
7755212000	2-212-N674-70	93259		7850000129	3057-36	98440	
7755214000	2-214-N674-70	93259		7872000021	9023-STK	13445	
7755216000	2-216-N674-70	93259		7872000030	112F	77326	
7755218000	2-218-N674-70	93259		7872000044	9055	13445	
7755219000	2-219-N674-70	93259		7872000048	2266262	06853	
7755220000	2-220-N674-70	93259		7872000062	5584-STK	13445	
7755222000	2-222-N674-70	93259		7872000107	40558	16476	
7755225000	2-225-N674-70	93259		7872000112	7770	13445	
7755258000	2-258-N674-70	93259		7872000114	9242	13445	
7755258609	2-258-N300-90	93259		7872000115	9224	13445	
7755266000	2-266-N674-70	93259		7872000121	1120	77326	
7755266400	4-266-366Y	07322		7872000127	SW721025A	13445	
7755277000	2-277-N674-70	93259		7872000134	71016	13445	
7755325000	2-325-N674-70	93259		7872000147	M712-01	13445	
7755325609	8-325-N300-90	93259		7872000158	SW721026A	13445	
7755334000	2-334-N674-70	93259		7872000163	286404	06853	
7755334609	8-334-N300-90	93259		7872000164	573(37179E)	77326	
7755358000	2-358-N674-70	93259		7872000181	X1597	77326	
7755425000	2-425-N674-70	93259		7872000203	9075-STK	13445	
7755425609	8-425-N300-90	93259		7880000011	226053	06853	
7755429000	2-429-N674-70	93259		7880000018	226110	06853	
7755433000	2-433-N674-70	93259		7880000019	226189	06853	
7755433609	8-433-N300-90	93259		7880000020	225000	06853	
7755444000	2-444-NN674-70	93259		7880000029	3989	96440	

MANUFACTURER TO VENDOR CROSS REFERENCE INDEX

<u>PART NUMBER</u>	<u>VENDOR PART NUMBER</u>	<u>VENDOR CODE</u>	<u>QTY PER VEHICLE</u>	<u>PART NUMBER</u>	<u>VENDOR PART NUMBER</u>	<u>VENDOR CODE</u>	<u>QTY PER VEHICLE</u>
7880000075	434	00165		9049101488	2258-R-408	78500	
7880000102	C254385	33457		9049101491	1299-M-1599	78500	
7888000001	#1/2-MMO-S	87373		9049101492	A-2297-D-862	78500	
7888000018	1/8" STD. PIPE TEE	82666		9049101493	119-V-1712	78500	
7888000031	8MT-8F-8F	72807		9049101497	13X-41	78500	
7888000033	4MT-4F-4F	72807		9049101498	15X-1025	78500	
7888000037	12MT-12F-12F	72807		9049101500	2208-G-501	78500	
7888000039	45 X 4	79470		9049101508	1229-T-1606	78500	
7888000078	3/4" STD. TEE	82666		9049101509	2233-W-158	78500	
7888000085	3750 X 2	79470		9049101511	3892-D-1798	78500	
7888000089	2091-6-6S	00624		9049101512	1229-H-1594	78500	
7888000094	2091-12-12S	00624		9049101513	3262-H-112	78500	
7888000098	2092-2-2S	00624		9049101514	2208-F-500	78500	
7888000099	271-P 1/8 X 1/8	88220		9049101515	1227-D-940	78500	
7888000101	637 1/2	82666		9049101516	1229-S-1605	78500	
7900000097	1100X20-12PLY NDM&S	73808		9049101517	65237	78500	
7900000112	1100X20 14PLY NDM&S	73808		9049101518	65500	60038	
7904000078	TA-482-1635	73808		9049101519	1244-G-787	78500	
7926000139	280479	06853		9049101520	3892-F-1826	78500	
7926000154	989174	10129		9049101521	2203-F-2788	78500	
7926000168	988831	10129		9049101522	2203-G-2789	78500	
7926000173	996702	10129		9049101523	2203-H-2790	78500	
7926000199	275176	06853		9049101535	H-715311	60038	
7926000207	227704	06853		9049101536	H-715343	60038	
7926000209	281923	06853		9049101547	1246-D-290	78500	
7926000210	223444	06853		9049101548	1229-X-518	78500	
7926000211	54088	36581		9049101549	N-110	78500	
7926000216	223869	06853		9049101553	10X-546	78500	
7926000219	998751	77521		9049101554	1229-T-1554	78500	
7926000222	A20-TC-1030(B200)-30	13829		9049101558	SN-1020	78500	
7926000223	A20-SH-1030(2250)-30	13829		9049101560	4X-1051	78500	
7926000224	A20-TB-1030	13829		9049101567	2208-C-445	78500	
7926000225	A20-SJ-1030	13829		9049101570	A-1805-D-212	78500	
7926000228	A35-LA57	13829		9049101572	A-119-P-1394	78500	
7926000229	A35-SL-1030	13829		9049101602	1246-D-342	78500	
7926000232	A35-HA194-(B2000)-40	13829		9049101605	1205-T-696	78500	
7926000273	220332	06853		9049101606	A1205-N-612	78500	
7926000275	A20-TA1030(A1500-81500-30)	13829		9049101607	A1199-S-1917	78500	
7926000278	1513-3-10	04962		9049101608	119-B-1666	78500	
7926000311	2232B-4MM	34362		9049101609	59SA	60038	
7926000353	A35-SK10300-(2500)-40	13829		9049101610	9734100120	78500	
7926000377	A35-HA182A500-40	13829		9049101612	AE-30334	28158	
7926000429	A20-Y82	13829		9049101616	DA-30359-14	28158	
7926000455	285507	06853		9049101619	AE-29749	28158	
7926000460	288729	06853		9049101620	AE-30574	28158	
7296000487	277148	06853		9049101628	WP-55	73972	
7926000491	989476	10129		9049101632	WP-36	73972	
7926000530	275756	06853		9049101643	2758-C-55	78500	
7926000531	41502	53203		9049101682	K-2412	78500	
7926000542	39362-7	94431		9049101700	1250-2-182	78500	
7926000576	A35-LA170	13829		9049101701	3299-X-1870	78500	
7926000608	286364	06853		9049101702	1227-W-517	78500	
7926000611	A20-SH-1030(2500)-30	13829		9049101703	1227-R-330	78500	
7926000619	286370	06853		9049101704	1229-U-1009	78500	
7926000631	286371	06853		9049101705	1229-U-1503	78500	
7926000644	286373	06853		9049101709	1718-D-134	78500	
7926000701	987215(2700PSI)	10129		9049101710	S-146	78500	
7926000770	987308	10129		9049101712	WA-14	78500	
7926000797	988858	10129		9049101713	A-1705-K-219	78500	
7926000805	MJTY-3	90526		9049101717	1729-B-262	78500	
7926000806	112381	11331		9049101720	1779-M-195	78500	
7949000162	JA43268	60380		9049101722	2797-Y-415	78500	
7949000166	JA-45253	60380		9049101723	2797X-414	78500	
7949000190	TW-115	60038		9049101724	A2747-G-11	78500	
7970000366	3204-1	73972		9049101726	1718-P-198	78500	
7970000371	3245-1	73972		9049101727	2758-Y-181	78500	
7970000587	WP-182	73972		9049101728	1729-X-336	78500	
9049101466	S-2712-1	78500		9049101729	1705-W-231	78500	
9049101469	1229-E-1513	78500		9049101730	1729-W-335	78500	
9049101473	3280-G-2529	78500		9049101731	1779-Q-433	78500	
9049101475	1229-F-1514	78500		9049101754	2797-D-56	78500	
9049101477	2208-M-429	78500		9049101755	A73-1779-V-230	78500	
9049101479	1229-C-1017	78500		9049101756	A3-3780-R-122	78500	
9049101481	A-3280-D-2448	78500		9049101757	2797-V-100	78500	
9049101485	2258-L-402	78500		9049101758	15X-725	78500	
9049101486	1229-R-798	78500		9049101760	1727-N-40	78500	

MANUFACTURER TO VENDOR CROSS REFERENCE INDEX

PART NUMBER	VENDOR PART NUMBER	VENDOR CODE	QTY	PART NUMBER	VENDOR PART NUMBER	VENDOR CODE	QTY
			PER VEHICLE				PER VEHICLE
9049101761	3736-D-784	78500		9049103112	479820	78500	
9049101762	1229-S-513	78500		9049103113	2214-X-50	78500	
9049101763	1707-C-3	78500		9049103114	1199-M-2457	78500	
9049101794	2203-A-2835	78500		9049103126	2208-X-440	78500	
9049101795	2203-N-3004	78500		9049103130	2203-P-6126	78500	
9049101796	2203-M-3003	78500		9049103131	2203-Q-6127	78500	
9049101802	T-208	78500		9049103132	2203-R-6128	78500	
9049101805	16X-204	78500		9049103133	2203-S-6129	78500	
9049101806	13X-159	78500		9049103134	2203-T-6130	78500	
9049101807	K-2618	78500		9049103135	2203-U-6131	78500	
9049101810	3133-J-1882	78500		9049103136	2203-V-6132	78500	
9049101811	3133-K-1883	78500		9049103137	2203-W-6133	78500	
9049101813	2257-S-19	78500		9049103138	2203-X-6134	78500	
9049101814	S-11022-C	78500		9049103139	2203-Y-6135	78500	
9049101815	N-710-C	78500		9049103140	2203-Z-6136	78500	
9049101822	2758-W-127	78500		9049103141	2203-A-6137	78500	
9049101835	1227-Y-571	78500		9049103142	2203-B-6138	78500	
9049101836	1229-C-1693	78500		9049103143	2203-C-6139	78500	
9049101980	1229-C-11511	78500		9049103144	2203-D-6140	78500	
9049102088	N-110-1	78500		9049103145	2203-E-6141	78500	
9049102158	1229-E-993	78500		9049103146	2203-F-6142	78500	
9049102160	1229-D-992	78500		9049103147	2203-G-6143	78500	
9049102416	2847-V-308	78500		9049103148	2203-H-6144	78500	
9049102448	AE-30087	28158		9049103149	2203-J-6146	78500	
9049102550	N-14	78500		9049103154	5-X-591	78500	
9049102551	K-235	78500		9049103156	15-X-1337	78500	
9049102560	2747-G-111	78500		9049103159	A-1199-S-1709	78500	
9049102569	2203-B-2836	78500		9049103160	NL 16-1	78500	
9049102572	K-2824	78500		9049103170	H-715334	78500	
9049102826	552A	60038		9049103173	A1-1705-K-219	78500	
9049103001	NL-110-1	78500		9049103174	2297-G-2373	78500	
9049103054	A2-3200-H-606	78500		9049103175	A-2297-F-2372	78500	
9049103057	1228-X-154	78500		9049103176	MFS-2178	78500	
9049103058	1199-Z-1430	78500		9049103177	A-1199-Z-3432	78500	
9049103059	1229-U-1113	78500		9049103139	N-35-P	78500	
9049103061	2203-U-645	78500		9049103346	3100-R-6102	78500	
9049103062	2203-V-646	78500		9049103347	A16-3111-A-2055	78500	
9049103063	2203-W-647	78500		9049103348	A19-3111-X-2052	78500	
9049103064	2203-X-648	78500		9049103349	15-X-1314	78500	
9049103065	2203-Y-649	78500		9049103352	A-3111-A-2055	78500	
9049103066	2203-Z-650	78500		9049103353	A-3111-X-2052	78500	
9049103067	2203-A-651	78500		9049103354	1225-L-818	78500	
9049103068	2203-B-652	78500		9049103355	3101-V-178	78500	
9049103069	2203-C-653	78500		9049103356	7--X-113	78500	
9049103070	2203-D-654	78500		9049103357	7-X-114	78500	
9049103071	2203-E-655	78500		9049103358	1199-M-3237	78500	
9049103072	2203-F-656	78500		9049103359	2208-R-824	78500	
9049103073	2203-G-657	78500		9049103361	3133-N-48650	78500	
9049103074	2203-H-658	78500		9049103362	A1-3102-Y-3847	78500	
9049103075	2203-J-660	78500		9049103365	1227-Z-780	78500	
9049103076	2203-K-661	78500		9049103367	A-1205-Y-1429	78500	
9049103077	2203-L-663	78500		9049103368	A-1205-C-1433	73500	
9049103078	2203-M-663	78500		9049103369	NL-212-1	78500	
9049103079	2203-N-664	78500		9049103370	A13-3211-2314	78500	
9049103080	2203-P-666	78500		9049103371	A13-3211-2315	78500	
9049103081	2203-Q-667	78500		9049103373	A6-3722-U-359	78500	
9049103082	2203-R-668	78500		9049103376	2797-B-106	78500	
9049103083	2203-S-669	78500		9049103377	A3-3790-N-66	78500	
9049103084	2203-T-670	78500		9049103378	2797-G-111	78500	
9049103085	2203-U-671	78500		9049103379	1199-A-3797	78500	
9049103086	2203-V-672	78500		9049103380	3236-E-1799	78500	
9049103087	2203-H-996	78500		9049103406	FA-705	73972	
9049103088	2203-J-998	78500		9049103407	W-778	73972	
9049103089	2203-K-999	78500		9049103409	3046	73972	
9049103090	2203-L-1000	78500		9049103410	W-845	73972	
9049103091	2203-M-1001	78500		9049103411	W-834	73972	
9049103092	2203-N-1002	78500		9049103412	W-823	73972	
9049104093	2203-P-1004	78500		9049103413	W-855	73972	
9049103094	2203-Q-1005	78500		9049103553	RA-304-F	73972	
9049103095	2203-R-1006	78500		9049103554	W-752	73972	
9049103102	2203-L-1260	78500		9049103555	W-776	73972	
9049103103	2203-A-469	78500		9049103556	2517-N	73972	
9094103105	A32-3235-N-1106	78500		9049103753	S-21013-1	78500	
9049103106	S-21022-1	78500		9049103754	S-268-1	78500	
9049103108	3278-A-79	78500		9049103755	1229-K-1597	78500	
9049103109	2233-U-99	78500		9049103760	3299-F-4530	78500	
9049103111	47890	78500		9049103761	3299-H-4532	78500	

MANUFACTURER TO VENDOR CROSS REFERENCE INDEX

PART NUMBER	VENDOR PART NUMBER	VENDOR CODE	QTY PER VEHICLE	PART NUMBER	VENDOR PART NUMBER	VENDOR CODE	QTY PER VEHICLE
9049103762	S-11018-1	78500		9049104407	D90-3200-H-606	78500	
9049103765	A1-3235-N-1106	78500		9049104408	C23-3121-J-10	78500	
9049103766	A-35914	78500		904910461	SN-613-1	78500	
9049103768	S-21019-1	78500		9188100058	01-0631	22075	
9049103769	C5-3121-K-11	78500		9188100059	150-2681	22075	
9049103772	RDA-1570-3999	78500		9188100061	13-1045-0000-7	22075	
9049103773	RDA-1570-4000	78500		9188100063	10-1131-0000-1	22075	
9049103774	A13-3211-2720	78500		9189100150	12-03052	22075	
9049103775	A27-3722-360	78500		9188100155	12-03063	22075	
9049103776	X12-3276-12	78500		9118100209	1229-E-1669	22075	
9049103777	X13-3276-12	78500		9270100813	065985	77640	
9049103778	2000-760	78500		9270101275	DA30240-2	28150	
9049103828	1229-V-1556	78500		9270101469	BA-6572	28150	
9049103965	N-410-1	78500		9274100104	S-266	78500	
9049103995	A2-3200-R-1162	78500		9274100280	82NYS31-37	78500	
9049103998	JH21749	78500		9274100281	PN-C02-32-6	78500	
9049103999	3278-Y-259	78500		9274100297	N-16-1	78500	
9049104000	2234-M-793	78500		9304100001	P11-7437	18265	
9049104003	A-3226-E-629	78500		9304100002	P10-0866	18265	
9049104004	JH211710	78500		9304100003	P10-6771	18265	
9049104005	2203-Q-6803	78500		9304100004	P10-9297	18265	
9049104006	2203-R-6804	78500		9304100005	P10-3198	18265	
9049104007	2203-S-6805	78500		9316100033	AC2-215	36479	
9049104008	A5-3261-Z-104	78500		9316100034	C71-22	36479	
9049104009	1229-W-1245	78500		9316100035	AC1-175	36479	
9049104014	S-11016-1	78500		9316100036	X72-59	36479	
9049104090	1707-B-2	78500		9316100037	X10-1	36479	
9049104093	NP-35	78500		9316100038	X50-43	36479	
9049104096	26752-32	28158		9316100039	C65-29	36479	
9049104174	X49-3276-L-12	78500		9316100040	X50-44	36479	
9049104175	X48-3276-L-12	78500		9316100041	AC74-28	36479	
9049104179	3100-Q-6101	78500		9316100042	C73-37	36479	
9049104180	S-259-1	78500		9316100043	C73-23	36479	
9049104181	2110-A-209	78500		9316100044	C6-58	36479	
9049104182	N-214-1	78500		9316100045	C60-87	36479	
9049104183	26-X-146	78500		9316100046	140-6-789	36479	
9049104184	Y4-3276-P-16	78500		9316100047	140-6-788	36479	
9049104185	A-3144-G-449	78500		9316100048	C5-108	36479	
9049104186	A-3144-F-448	78500		9316100049	C25-46	36479	
9049104187	A37-1779-X-232	78500		9316100050	K-259	36479	
9049104188	A-3780-S-123	78500		9326100002	477180	77640	
9049104189	2000-P-484	78500		9326100004	026115	77640	
9049104360	A77-3200-R-1162	78500		9326100005	477113	77640	
9049104373	15-X-1515	78500		9326100006	028104	77640	
9049104374	15-X-1514	78500		9326100007	091306-A2-3400	77640	
9049104375	2234-F-344	78500		9326100008	401254	77640	
9049104376	A-1205-P-1368	78500		9326100009	028292	77640	
9049104377	3228-N-6748	78500		9326100010	029085	77640	
9049104378	A2-3235-B-1250	78500		9326100011	403722-A1	77640	
9049104379	KIT 389	78500		9326100013	45604-A5-2800	77640	
9049104380	1221-V-2570	78500		9326100014	480887	77640	
9049104381	13-X-163	78500		9326100015	032308	77640	
9049104382	S-1813-1	78500		9326100017	456064-S1	77640	
9049104833	A3280-A-6735	78500		9326100018	065987	77640	
9049104384	3280-L-6720	78500		9326100020	055025-1000	77640	
9049104385	1229-C-2057	78500		9326100021	G274883	77640	
9049104386	JLM104910	78500		9326100022	G441197	77640	
9049104387	A-3226-W-699	78500		9326100023	402265	77640	
9049104388	1227-J-946	78500		9326100024	032307	77640	
9049104389	LM104949	78500		9326100025	0131292	77640	
9049104390	3202-T-6728	78500		9326100026	051044	77640	
9049104391	3202-U-6729	78500		9326100027	G159229	77640	
9049104392	3280-W-6757	78500		9326100028	021193	77640	
9049104393	1229-T-1736	78500		9326100029	025082	77640	
9049104394	1229-P-2590	78500		9326100030	G106261	77640	
9049104395	1229-Q-2591	78500		9326100033	028417	77640	
9049104396	1229-R-2592	78500		9326100034	032200-7	77640	
9049104397	1229-S-2593	78500		9326100035	403722A-4-3300	77640	
9049104398	1229-T-2594	78500		9332100036	202981	06853	
9049104399	1229-U-2595	78500		9332100113	240345	06853	
9049104400	1229-V-2596	78500		9348100026	211309	06853	
9049104401	1229-W-2597	78500		9348100027	217224	06853	
9049104402	1229-X-2598	78500		9348100028	239139	06853	
9049104403	1229-Y-2599	78500		9348100029	243950	06853	
9049104404	A-35444-10	78500		9348100030	243939	06853	
9049104405	A3226-U-723	78500		9348100031	243937	06853	
9049104406	A1-1805-s-149	78500		9348100032	243940	06853	

MANUFACTURER TO VENDOR CROSS REFERENCE INDEX

PART NUMBER	VENDOR PART NUMBER	VENDOR CODE	QTY PER VEHICLE	PART NUMBER	VENDOR PART NUMBER	VENDOR CODE	QTY PER VEHICLE
9348100033	238956	06853		9372100312	223398	06853	
9348100034	242221	06853		9372100313	223416	06853	
9348100035	239071	06853		9372100314	231249	06853	
9348100126	11M037	50153		9372100315	231144	06853	
9344100127	11M114	50153		9372100316	231143	06853	
9348100130	11M014	50153		9372100317	231156	06853	
9348100133	11428RS	50153		9372100318	231146	06853	
9348100148	11M011	50153		9372100319	230392	06853	
9344100149	48M002	50153		9372100320	231149	06853	
9348100150	48M006	50153		9372100321	231157	06853	
9348100151	48M003	50153		9372100322	231160	06853	
9348100152	48M009	50153		9372100323	231161	06853	
9348100153	48M005	50153		9372100324	233607	06853	
9348100154	48M001	50153		9372100325	232999	06853	
9348100155	48M038	50153		9372100326	230111	06853	
9352100001	14015	52304		9372100327	231150	06853	
9352100002	14016	52304		9372100328	231147	06853	
9352100003	16385	52304		9372100329	231145	06853	
9352100004	16388	52304		9372100330	231152	06853	
9352100005	14975	52304		9372100331	231159	06853	
9352100006	14441	52304		9372100332	240546	06853	
9352100007	14974	52304		9372100397	28-030-002	92865	
9352100008	A-3925	52304		9372100398	33-113-017	92865	
9352100009	X-1-601	52304		9372100400	20-080-006	92865	
9352100010	X-1-603	52304		9372100402	30-760-004	92865	
9352100011	11066	52304		9372100403	32-080-004	92865	
9352100012	13788	52304		9372100404	32-660-029	92865	
9352100013	13790	52304		9372100405	33-115-014	92865	
9352100014	X-8L-500	52304		9372100406	33-115-015	92865	
9352100015	13789	52304		9372100420	FC-5908	63477	
9352100016	16387	52304		9372100421	FD-4504	63477	
9352100017	16377	52304		9372100422	FC-5910	63477	
9352100018	16386	52304		9372100423	FD-4505	63477	
9352100019	X-7-706	52304		9372100424	FC-5916	63477	
9332100020	6716	52304		9372100425	FC-5917	63477	
9352100021	13944	52304		9372100426	FC-5921	63477	
9352100022	X-8-518	52304		9372100428	FC-6019	63477	
9352100023	13950	52304		9372100429	FC-12103	63477	
9352100024	13948	52304		9372100615	32131	94431	
9352100025	13949	52304		9372100619	39192	94431	
9352100026	16401	52304		9372100620	32662-15	94431	
9352100027	15313	52304		9372100621	32727	94431	
9352100028	4759	52304		9372100648	FC-48486	63477	
9352100029	13952	52304		9372100650	FC-6858	63477	
9352100030	16402	52304		9372100652	37917	94431	
9352100031	13947	52304		9372100653	32986	94431	
9352100032	13951	52304		9372100654	37913	94431	
9364100002	RC-861	52729		9372100655	37914	94431	
9364100083	RC-8010	52729		9372100656	41509	94431	
9364100084	RC-8004	52729		9327100657	41308	94431	
9364100085	RC-8005	52729		9372100658	32979	94431	
9364100087	RC-8021	52729		9372100659	32978	94431	
9364100088	RC-8022	52729		9372100660	37912	94431	
9364100091	RC-8023	52729		9372100661	32463	94431	
9364100092	RC-8024	52729		9372100800	32-620-014	92865	
9364100101	NU-SL20-18-2	78500		9372100802	32-660-032	92865	
9364100109	3NLS24	78500		9372100804	32-620-013	92865	
9364100176	RC-8094	78500		9372100809	32-660-031	92865	
9364100177	RC-8082	78500		9372100821	32-690-002	92865	
9364100178	RC-8140	52729		9372100824	32-690-047	92865	
9364100179	RC-8139	52729		9372100851	30-100-126	92865	
9364100180	RC-8066	52729		9372100852	30-030-028	92865	
9364100181	RC-8084	52729		9372100853	30-010-027	92865	
9364100188	CP68WB-10	78500		9372100854	30-620-017	92865	
9364100189	72NLS32-2	78500		9372100855	30-010-044	92865	
9364100190	DC72N-1	78500		9372100856	30-030-024	92865	
9364100191	954-55-43096	78500		9372100857	30-200-002	92865	
9364100192	PLD6-27-1	78500		9372100858	32-260-046	92865	
9364100193	CS-H7-20-14	78500		9372100859	30-010-025	92865	
9364100194	WA-LH8-3	78500		9372100860	30-760-005	92865	
9364100251	1610-BL	78500		9372100861	30-900-004	92865	
9364100252	DC4N-1	78500		9372100862	33-115-018	92865	
9364100253	L16SF191	78500		9372100863	30-190-007	92865	
9364100254	922-55-41379	78500		9372100864	32-570-004	92865	
9364100280	CP02N	78500		9372100865	02-001-005	92865	
9364100281	82NLS40-26	78500		9392100004	24-70A	71741	
9372100311	231139	06853		9392100005	204P-10	71741	

MANUFACTURER TO VENDOR CROSS REFERENCE INDEX

		QTY			QTY		
	VENDOR	VENDOR	PER	VENDOR	VENDOR	PER	
PART NUMBER	PART NUMBER	CODE	VEHICLE	PART NUMBER	PART NUMBER	CODE	VEHICLE
9392100006	209-34	71741		9515100196	8008	92878	
9392100009	215-10	71741		9515100201	3505	92878	
9392100010	211-120	71741		9515100216	5697	92878	
9392100011	209-10	71741		9515100217	47632	92878	
9392100012	203-284	71741		9515100221	47434	92878	
9392100013	1208-0113 LH.	71741		9515100222	47714	92878	
9392100014	205-10	71741		9515100223	2-47318	92878	
9392100015	204P-32	71741		9515100225	47542	92878	
9392100019	16-75	71741		9515100229	1-47413	92878	
9392100021	216-10R	71741		9515100231	47037	92878	
9392100022	204-10R	71741		9515100247	2084	92878	
9392100023	224-63R	71741		9515100249	510243	92878	
9392100024	223-69R	71749		9515100250	26243	92878	
9392100025	1212-0023RH	71741		9513100251	73270	92878	
9392100042	1011-0079	71741		9515100263	400383	92878	
9437100141	P16-0134	18265		9515100264	47741-01	92878	
9437100142	P16-0135	18265		9515100283	170301	92878	
9437100143	P16-0050	18265		9515100284	47649	92878	
9437100144	P16-0048	18265		9513100285	49084	92878	
9413700150	P16-0137	18265		9315100286	3034	92878	
9437100151	P10-7923	18265		9515100287	7020	92878	
9437100155	P16-0125	18265		9515100288	7019	92878	
9437100156	P10-0470	18265		9515100289	49057	92878	
9437100157	P16-0130	18265		9515100290	2-49196	92878	
9437100185	P16-0293	18265		9515100291	49062	92878	
9437100186	P16-0353	18265		9515100292	49024	92878	
9437100212	P16-0473	18265		9515100293	2-49199	92878	
9437100215	P16-0476	18265		9515100294	2-49188	92878	
9437100217	P16-0710	18265		9515100295	49013	92878	
9437100218	P16-0749	18265		9515100296	49012	92878	
9437100223	P12-4533	18265		9515100297	2-47023	92878	
9437100224	P01-7336	18265		9515100298	47008	92878	
9437100225	P10-0789	18265		9515100300	2-49182	92878	
9486100004	10020	54220		9515100301	49061	92878	
9486100005	10010	54220		9515100302	2-49180	92878	
9486100006	10021	54220		9515100003	70294	92878	
9486100007	10022	54220		9515100304	49016	92878	
9486100008	10024-501	54220		9515100305	1-49191	92878	
9486100009	10025-501	54220		9515100306	26370	92878	
9486100010	10012	54220		9515100307	1591	92878	
9486100011	ZSP10-1003-3	54220		9515100308	2-47971	92878	
9486100012	10013	54220		9515100309	10512-01	92878	
9486100013	10016-501	54220		9515100310	48389	92878	
9486100014	10017	54220		9515100311	48090	92878	
9486100015	1018-501	54220		9515100312	1601	92978	
9486100016	324-004A	54220		9515100313	5360	92313	
9486100017	10023	54220		9313100314	2-49185	92878	
9490100005	069011	77640		9513100315	68122-01	92878	
9490100006	032074	77640		9515100316	49032	92878	
9490100007	402246	77640		9515100317	49072	92878	
9490100008	037014	77640		9515100318	2299	92878	
9490100011	400076(AI)	77640		9515100319	7009	92878	
9490100013	044952(A1)	77640		9515100320	48343	92878	
9490100014	025003	77640		9515100321	47316	92878	
9490100015	G120731	77640		9513100322	4034	92878	
9490100016	TE705002	77640		9515100323	2-48344	92878	
9490100017	021065	77640		9515100324	48352	92878	
9490100018	025031	77640		9515100325	1-47451-01	92878	
9490100019	020190	77640		9515100326	4443	92878	
9490100020	TE709002	77640		9515100327	4348	92878	
9490100022	032223	77640		9515100328	68353	92878	
9490100023	020189	77640		9515100329	48355	92878	
9490100024	033042	77640		9515100330	48336	92878	
9490100025	033036	77640		9515100331	3504	92878	
9490100026	033037	77640		9515100332	49055	92878	
9490100085	TE102002-51-325	77640		9515100333	2-49139	92878	
9490100086	TE703122-J1	77640		9515100334	2-47340	92878	
9490100087	40020-S1	77640		9515100335	47752	92878	
9490100088	TE704002-A15-625	77640		9515100336	1-47754	92878	
9490100089	TE705002-S1	77640		9515100337	2-47849	92878	
9490100090	TE706002-X1	77640		9515100338	49031	92878	
9490100091	028015	77640		9515100339	13336	92878	
9490100092	025084	77640		9515100340	2-49197	92878	
9515100169	13802	92878		9515100341	49093	92878	
9515100187	1169	92878		9515100342	2-49192	92878	
9515100189	3259	92878		9515100343	49048	92878	
9515100195	3901	92878		9515100344	4373	92878	

MANUFACTURER TO VENDOR CROSS REFERENCE INDEX

<u>PART NUMBER</u>	<u>VENDOR PART NUMBER</u>	<u>VENDOR CODE</u>	<u>QTY PER VEHICLE</u>	<u>PART NUMBER</u>	<u>VENDOR PART NUMBER</u>	<u>VENDOR CODE</u>	<u>QTY PER VEHICLE</u>
9515100345	170302	92878		9722100037	TA1133	13829	
9515100346	2-49186	92878		9722100042	X89-16	13829	
9515100347	4374	92878		9722100045	RA-1603	13829	
9515100348	2-49149	92878		9722100046	X144-3	13829	
9515100349	2-49179	92878		9722100053	MA1638-10	13829	
9515100350	3405	92878		9722100054	KA1007M-10	13829	
9515100351	49023	92878		9722100055	TA1519-3	13829	
9515100352	47486	92878		9722100056	X115-20	13829	
9515100353	2-47630	92878		9722100123	K3026-22	13829	
9515100354	47852	92878		9722100227	AB1402-17	13829	
9515100355	47417	92878		9722100228	AE1402-9	13829	
9515100356	49041	92878		9722100229	X4-76	13829	
9515100357	2-47728	92878		9722100372	T1391	13829	
9515100358	2-49183	92878		9722100511	S-255	78500	
9515100359	10599-01	92878		9722100512	S-2313-1	78500	
9515100360	49069	92878		9722100535	4023537	96105	
9515100361	2086	92878		9722100536	F65198	96105	
9515100362	3897	92878		9722100537	4023326	96105	
9515100363	49067	92878		9722100538	F19003-4	96105	
9515100364	49085	92878		9722100539	F19003-8	96105	
9515100365	47237	92878		9722100540	F20200	96105	
9515100366	49017	92878		9722100541	F32100-4	96105	
9515100367	47273	92878		9722100542	F68300	96105	
9515100368	47170	92878		9722100543	4028051	96105	
9515100369	49010	92878		9722100544	4028042	96105	
9515100370	2-49195	92878		9722100545	F40211	96105	
9515100371	49068	92878		9722100546	4028538	96105	
9515100372	49066	92878		9722100547	F37030-265	96105	
9515100373	149PI-03-09-2042	92878		9722100548	F15008	96105	
9515100374	1490PI-03-09-1041	92878		9722100549	F13015	96105	
9515100375	1189-02-09-1103	92878		9722100550	4028056	96105	
9515100376	1190-02-09-2103	92878		9722100551	F37030-250	96105	
9515100377	2-49181	92878		9722100552	4028529	96105	
9581100023	5962548	73331		9722100553	F65199	96105	
9581100030	GE-4411	36618		9722100554	4028500	96105	
9581100033	GE-1156	36618		9722100555	F400113	96105	
9581100034	631	36618		9722100556	F39010-250	96105	
9581100035	GE-1157	36618		9722100557	F39000-393	96105	
9581100036	GE-1893	36618		9722100558	40283531	96105	
9581100037	GE-6015-PAR56	36618		9722100559	F39010-50	96105	
9632100006	70783	96151		9722100560	4028724	96105	
9632100015	616	96151		9722100561	4028532	96105	
9632100046	5777	96151		9722100562	4023534	96105	
9632100052	6049	96151		9722100563	4028535	96105	
9632100058	5776	96151		9722100564	F25156-16	96105	
9632100142	5389-5	96151		9722100565	F22030	96105	
9632100256	9055-1	96151		9722100665	F97501-001	96105	
9632100257	7463	96151		9722100667	V200-11-1C-RH	61038	
9632100258	9057-1	96151		9726100029	400-10	92857	
9632100259	7462	96151		9734100120	580	60038	
9632100260	7537	96151		9752100133	FC-33130	63477	
9632100261	7360-2	96151		9752100135	40505	94431	
9632100262	7359-2	96151		9752100183	287072	06853	
9632100263	7358	96151		9802100126	236982	06853	
9632100266	7461	96151		9904101254	X-3-801	52304	
9632100267	60023	96151		9904101256	X-3-600	52304	
9632100268	7357-5	96151		9904101257	X-8-808	52304	
9632100269	6901-3	96151		9904101261	X-14-800	52304	
9722100018	W-1072	13829		9904101262	1064	52304	
9722100019	X73-37-13	13829		9904101263	3220	52304	
9722100020	PB-1135	13829		9904101267	X-8L-604	52304	
9722100021	SA-1669	13829		9904101720	1634	52304	
9722100022	XA1686-3	13829		9904101731	1565	52304	
9722100023	L3006-26	13829		9904101745	X-8L-602	52304	
9722100024	X1126-8	13829		9904101794	1642	52304	
9722100025	YA1669-1	13829		9904101813	X-8L-600	52304	
9722100026	X97-100	13829		9904101827	X-1-1000	52304	
9722100027	AH-2010	13829		9904101828	X-3-1000	52304	
9722100028	A1327-182	13829		9904101852	1075	52304	
9722100029	S-1032	13829		9904101860	2271	52304	
9722100030	UB3006-244	13829		9904101861	X3-500	52304	
9722100031	391-2185-012	13829		9904101862	X1-500	52304	
9722100032	TA1519-6	13829		9904101878	X14-1200	52304	
9722100033	KA1007M-17	13829		9904101881	X8S-601	52304	
9722100034	MA1688-17-38	13829		9904101882	14575	52304	
9722100035	KA1687-3-31	13829		9904101883	1684	52304	
9722100036	AR2010	13829		9904101886	7992	52304	

MANUFACTURER TO VENDOR CROSS REFERENCE INDEX

<u>PART NUMBER</u>	<u>VENDOR PART NUMBER</u>	<u>VENDOR CODE</u>	<u>QTY PER VEHICLE</u>	<u>PART NUMBER</u>	<u>VENDOR PART NUMBER</u>	<u>VENDOR CODE</u>	<u>QTY PER VEHICLE</u>
9904101887	X12-2001	52304		9904102013	14765	52304	
9904101892	15917	52304		9904102014	14349	52304	
9904101893	13500	52304		9904102015	14344	52304	
9904101895	8968	52304		9904102016	14347	52304	
9904101898	10019	52304		9904102017	16778	52304	
9904101919	16252	52304		9904102018	16843	52304	
9904101920	62511	52304		9904102019	16795	52304	
9904101921	15446	52304		9904102020	X-7-506	52304	
9904101922	16230	52304		9904102021	X-8-614	52304	
9904101924	16250	52304		9904102022	16775	52304	
9904101925	15976	52304		9904102023	14897	52304	
9904101926	15980	52304		9904102024	16798	52304	
9904101928	16662	52304		9904102025	14335	52304	
9904101932	14286	52304		9904102026	16799	52304	
9904101933	15060	52304		9904102027	X-7-810	52304	
9904101934	1632	52304		9904102028	16816	52304	
9904101937	16792	52304		9904102029	X-8-679	52304	
9904101938	15050	52304		9904102030	15061	52304	
9904101939	14334	52304		9904102031	16227	52304	
9904101940	81046	52304		9904102032	16226	52304	
9904101941	81505	52304		9904102034	16228	52304	
9904101942	X-8-680	52304		9904102035	16229	52304	
9904101943	15981	52304		9904102036	16307	52304	
9904101944	15748	52304		9904102037	16234	52304	
9904101945	X-8-600	52304		9904102038	16789	52304	
9904101946	14993	52304		9904102041	X-10-801	52304	
9904101947	16810	52304		9904102042	X-1-803	52304	
9904101948	16809	52304		9904102043	15045	52304	
9904101949	16813	52304		9904102044	A-4096	52304	
9904101950	16812	52304		9904102045	17097	52304	
9904101951	16815	52304		9904102046	16724	52304	
9904101952	16811	52304		9904102047	16723	52304	
9904101958	14644	52304		9904102048	S1008	52304	
9904101959	14632	52304		9904102049	16817	52304	
9904101960	16801	52304		9904102050	12881	52304	
9904101961	15720	52304		9904102051	35002	52304	
9904101962	15020	52304		9904102052	15758	52304	
9904101964	81045	52304		9904102053	6392	52304	
9904101965	81551	52304		9904102054	15910	52304	
9904101970	15059	52304		9904102055	15096	52304	
9904101972	15971	52304		9904102056	15100	52304	
9904101973	15973	52304		9904102057	15097	52304	
9904101974	15977	52304		9904102058	16300	52304	
9904101975	16805	52304		9904102059	15101	52304	
9904101976	16800	52304		9904102063	X-12-404	52304	
9904101977	16253	52304		9904102064	15102	52304	
9904101978	X-6-128	52304		9904102066	12751	52304	
9904101979	16249	52304		9904102067	X-3-400	52304	
9904101980	16790	52304		9904102068	X-8-411	52304	
9904101981	1813	52304		9904102069	A-3991	52304	
9904101982	16793	52304		9904102070	12845	52304	
9904101983	14621	52304		9904102073	S4001	52304	
9904101984	14643	52304		9904102074	13571	52304	
9904101986	X-1-702	52304		9904102078	15132	52304	
9904101987	15719	52304		9904102079	15133	52304	
9904101988	15512	52304		9904102080	15605	52304	
9904101989	16963	52304		9904102081	15899	52304	
9904101991	14326	52304		9904102083	X-12-800	52304	
9904101992	16716	52304		9904102084	14373	52304	
9904101993	X-8-507	52304		9904102085	X-12-1201	52304	
9904101994	14327	52304		9904102086	16827	52304	
9904101995	16791	52304		9904102087	X-13-215	52304	
9904101996	14331	52304		9904102088	16828	52304	
9904101997	14332	52304		9904102089	9332	52304	
9904101998	14961	52304		9904102090	A-4041	52304	
9904101999	X-8-616	52304		9904102091	16865	52304	
9904102000	14367	52304		9904102093	16742	52304	
9904102001	16796	52304		9904102094	16744	52304	
9904102002	11956	52304		9904102095	16741	52304	
9904102003	14337	52304		9904102096	16975	52304	
9904102004	15532	52304		9904102097	X-8L-601	52304	
9904102007	A-3154	52304		9904102098	12769	52304	
9904102008	14799	52304		9904102099	6579	52304	
9904102009	X-1-1010	52304		9904102100	15701	52304	
9904102010	16993	52304		9904102101	16824	52304	
9904102011	14345	52304		9904102102	X-8-430	52304	
9904102012	14341	52304		9904102103	55505	52304	

MANUFACTURER TO VENDOR CROSS REFERENCE INDEX

PART NUMBER	VENDOR	VENDOR	QTY	PART NUMBER	VENDOR	VENDOR	QTY
	PART NUMBER	CODE	PER VEHICLE		PART NUMBER	PART NUMBER	CODE
9904102104	16743	52304		9926100584	408544	77521	
9904102105	11665	52304		9926100585	401024	10129	
9104102106	16929	52304		9926100586	408526	77521	
9904102107	16596	52304		9926100587	408522	77521	
9904102109	14494	52304		9926100588	356966	77521	
9904102110	55527	52304		9926100589	356963	77521	
9904102111	55507	52304		9926100590	493303	77521	
9904102112	55522	52304		9926100592	405928	77521	
9904102113	X-12-208	52304		9926100607	493316	77521	
9944102123	A-2268	52304		9926100610	356919	77521	
9904102124	A-4081	52304		9926100611	356833	77521	
9904102129	A-3990	52304		9926100612	356827	77521	
9904102146	86068	52304		9926100613	356813	77521	
9904102147	86087	52304		9926000614	401066	77521	
9904102661	12815	52304		9926100642	490618	77521	
9904102849	X9-602	52304		9926100644	356324	77521	
9904102888	17177	52304		9926100650	X45-9	13829	
9904102918	17106	52304		9926100651	AH1311	13829	
9904102933	X8-682	52304		9926100652	G1048	13829	
9904103207	15253	52304		9926100653	DA1023	13829	
9904103209	18196	32304		9926100654	A1327-129	13829	
9904103210	X-13-217	52304		9926100655	P1532	13829	
9904103211	17503	52304		9926100658	C1530-3	13829	
9904103212	17504	52304		9926100659	A1327-119	13829	
9904103213	A-4392	52304		9926100460	M1021	13829	
9904103226	1968	52304		9926100661	X45-20	13829	
9904103370	18408	52304		9926100662	AN 1311	13827	
9904103371	A-3711	52304		9926100663	H1048	13829	
9904103372	X-8L-703	52304		9926100664	GA1023	13829	
9904103373	18447	52304		9926100666	RA1532	13829	
9904103374	18439	52304		9926100667	MA3006-14	13829	
9904103375	17434	S2304		9926100670	VA1530	13829	
9904103376	17435	32304		9926100671	A1327-133	13829	
9904103377	17436	52304		9926100672	BE1021	13829	
9904103378	17437	52304		9926100674	X1-18	13829	
9904103379	18449	52304		9926100685	UA3006-13	13829	
9904103380	17259	52304		9926100686	S1025-13	13829	
9904103381	17260	52304		9926100687	V300-13	13829	
9904103382	17261	52304		9926100688	PC1530	13829	
9904103383	17262	52304		9926100689	L3006-62	13829	
9904103385	18448	52304		9926100690	J3010-6	13829	
9904103386	S-1250	52304		9926100691	WA1530	13829	
9904103387	18507	52304		9926100692	A1327-207	13829	
9904103388	18506	52304		9926100693	JB1021	13829	
9904103389	A-4388	52304		9926100694	G-1379	13829	
9904103425	86013	52304		9926100696	R3006-7	13829	
9926100142	131014	77521		9926100697	B1025-12	13829	
9926100147	402266	77521		9926100698	V300-15	13829	
9926100158	131914	10129		9926100699	HA1044	13829	
9926100284	405945	77521		9926100700	LA1530	13829	
9926100285	405654	10129		9926100701	L3006-43	13829	
9926100286	490710	77521		9926100702	J30310-8	13829	
9926100287	490709	77521		9926100703	TA1530	13829	
9926100288	403292	77521		9926100705	AB1021	13829	
9924100289	490309	10129		9926100706	F1379	13829	
9926100372	221617	77521		9926100714	S-1352-1	13829	
9926100378	306579	77521		9926100716	U-1352-1	13829	
9926100385	400697	77521		9926100717	L-3006-113	13829	
9926100386	400714	77521		9926100721	L-3006-106	13829	
9926100389	405363	77521		9926100722	L3006-112	13829	
9926100390	405377	77521		9926100723	L-3006-108	13829	
9926100392	405393	77521		9926100724	#306402	77521	
9926100394	405399	77521		9926100725	#407388	10129	
9926100397	405412	77521		9926100726	407340	77521	
9926100398	405467	77521		9926100727	407339	77521	
9926100399	405957	77521		9926100728	993170	77521	
9926100407	777262	77521		9926100730	405387	10129	
9926100410	777266	77521		9926100749	401271	10129	
9926100416	995411	77521		9926100760	493482	77521	
9926100575	401069	77521		9926100761	707583	77521	
9926100576	407816	77521		9926100762	999201-1	77521	
9926100577	406127	77521		9926100763	406460	77521	
9926100578	405331	77521		9926100764	407362	77521	
9926100579	356964	77521		9926100767	707421	10129	
9926100580	408539	77521		9926100769	355293	77521	
9926100581	356965	77521		9926100770	405914	77521	
9926100582	356962	77521		9926100771	355275	10129	

MANUFACTURER TO VENDOR CROSS REFERENCE INDEX

		QTY				QTY	
VENDOR		VENDOR		VENDOR		VENDOR	
PART NUMBER	PART NUMBER	CODE	PER VEHICLE	PART NUMBER	PART NUMBER	CODE	PER VEHICLE
9926100772	493428	77521		9926101335	2130-L	94431	
9926100773	355274	10129		9926101336	2132	94431	
9926100774	493459	10129		9926101337	2103	94431	
9926100775	355292	10129		9926101338	2104	94431	
9926100779	707434	77521		9926101339	2105	94431	
9926100786	356759	77521		9926101340	147	94431	
9926100787	404581	10129		9926101341	2107	94431	
9926100831	999201-2	10129		9926101342	2106	94431	
9926100832	999201-3	10129		9926101343	2108	94431	
9926100833	A1327-321	13829		9926101344	2135	94431	
9926100842	X1-17	13829		9926101345	32016	94431	
9926100843	355281	77521		9926101346	2199-5	94431	
9926100844	355284	77521		9926101379	A1327-151	13829	
9926100845	405921	10129		9926101380	240905	06853	
9926100846	405964	77521		9926101381	240906	06853	
9926100847	355288	77521		9926101382	240907	06853	
9926100848	355290	77521		9926101383	240908	06853	
9926100897	X1-5	13829		9926101384	240909	06853	
9926101099	P1041	13829		9926101390	203198	06853	
9926101100	FB1530	13829		9926101441	33752	94431	
9926101101	X30-17	13829		9926101442	32270	94431	
9926101102	X146-4	13829		9966101443	34217	94431	
9926101103	MA1044	13829		9926101445	31116	94431	
9926101104	A1327-267	13829		9926101447	38771-2	94431	
9926101105	DL91-36	13829		9926101448	32138	94431	
9926101106	UA3006-43	13829		9926101449	33154	94431	
9926101107	UA3006-44	13829		9926101472	202982	06853	
9926101108	B1025-7	13829		9926101496	239898	06853	
9926101109	UA3006-5	13829		9926101517	31298	94431	
9926101110	A1327-147	13829		9926101518	38772-7(1500PSI)	94431	
9926101111	S1041	13829		9926101519	202979	06853	
9926101112	A1327-139	13829		9926101520	235212	06853	
9926101128	A1327-208	13829		9926101521	238888	06853	
9926101147	102374	11331		9926101522	226834	06853	
9926101149	102371	11331		9926101527	236981	06853	
9926101154	114678	11331		9926101528	236979	06853	
9926101155	114537	11331		9926101531	236980	06853	
9926101156	111304	11331		9926101532	103670	11331	
9926101157	103111	11331		9926101565	41602	94431	
9926101160	103113	11331		9926101566	32505	94431	
9926101161	103704	11331		9926101567	32502	94431	
9926101243	356195	77521		9926101568	32504	94431	
9926101244	356951	77521		9926101569	32503	94431	
9926101245	360145	77521		9926101570	GB2116L	94431	
9926101246	360147	77521		9926101571	2162	94431	
9926101247	360148	77521		9926101572	32995-134	94431	
9926101248	360149	77521		9926101573	41695	94431	
9926101249	401016	77521		9926101614	405688	10129	
9926101250	407186	77521		9926101627	235063	06853	
9926101251	407229	77521		9926101637	290399	06853	
9926101252	407821	77721		9926101638	290405	06853	
9926101253	490518	77521		9926101639	235899	06853	
9926101254	490963	77521		9926101640	239219	06853	
9926101255	360146	77321		9926101641	290407	06853	
9926101259	X1-16	13829		9926101642	290406	06853	
9926101261	239643	06853		9926101643	286363	06853	
9926101262	239468	06853		9926101644	240161	06853	
9926101267	241559	06853		9926101645	290818	06853	
9926101273	239136	06853		9926101646	245257	06853	
9926101304	243969	06853		9926101647	240540	06853	
9926101305	243968	06853		9926101648	290404	06853	
9926101315	111411	11331		9926101649	290410	06853	
9926101318	103110	11331		9926101650	249534	06853	
9926101319	106857	11331		9926101651	241205	06853	
9926101321	2143	94431		9926101652	243646	06853	
9926101322	38409	94431		9926101653	202620	06853	
9926101323	2144	94431		9926101654	247253	06853	
9926101324	32394	94431		9926101655	247252	06853	
9926101325	2131	94431		9926101656	247208	06853	
9926101326	32266	94431		9926101657	230576	06853	
9926101327	2139	94431		9926101666	249313	06853	
9926101328	2160	94431		9926101667	249371	06853	
9926101329	2136	94431		9926101668	239943	06853	
9926101330	32119	94431		9926101669	24228	06853	
9926101332	32116	94431		9926101676	114378	11331	
9926101333	2102	94431		9926101726	239029	06853	
9926101334	37335	94431		9926101728	248536	06853	

MANUFACTURER TO VENDOR CROSS REFERENCE INDEX

PART NUMBER	VENDOR PART NUMBER	VENDOR CODE	QTY PER VEHICLE	PART NUMBER	VENDOR PART NUMBER	VENDOR CODE	QTY PER VEHICLE
9926101729	247216	06853		9974100032	B11044	36581	
9926101730	247217	06853		9974100037	51008	36581	
9926101732	247219	06853		9974100039	A11035	36581	
9926101733	247220	06853		9974100040	C11055	36581	
9926101736	290202	06853		9974100041	50513	36581	
9926101737	247226	06853		9974100042	50428	36581	
9926101738	290186	06853		9974100049	A11006	36581	
9926101739	247231	06853		9974100054	51007	36581	
9926101741	290187	06853		9974100056	B11064	36581	
9926101742	290191	06853		9974100058	51006	36581	
9926101743	290185	06853		9974100059	A11074	36581	
9926101744	290189	06853		9974100060	50573	36581	
9926101745	290188	06853		9974100067	C11007	36581	
9926101746	248534	06853		9974100070	50363	36581	
9926101747	244435	06853		9974100071	50307	36581	
9924101748	244437	06853		9974100073	50515	36581	
9926101749	244438	06853		9974100075	50998	36581	
9926101750	234045	06853		9974100076	50997	36581	
9926101751	244439	06853		9974100077	51000	36581	
9926101752	244440	06853		9974100078	A11025	36581	
9926101775	408870	77251		9974100079	51002	36581	
9926101784	279754	06853		9974100080	50325	36581	
9926101839	CA6625K-2(2250PSI)	13829		9974100081	A11062	36581	
9926101841	CA6625K-1(2000PSI)	13829		9974100082	B11017	36581	
9926101842	DZ6625K-1(2250PSI)	13829		9974100083	C11008M	36581	
9926101845	BX6625K-1(1500PSI)	13829		9974100084	50395	36581	
9926101847	BL6625K-2(2500PSI)	13829		9974100085	C11010M	36581	
9926101848	CA6625K-3(500PSI)	13029		9974100086	50367	36581	
9926101849	DZ6625K-1(2500PSI)	13829		9974100087	50337	36581	
9926101856	L3006-40	13829		9974100089	C11009C	36581	
9926101987	286171	06853		9974100090	50339	36581	
9926101989	286170	06853		9974100091	50368	36581	
9926101989	286169	06853		9974100092	50297	36581	
9926101990	248338	06853		9974100093	B11057	36581	
9926101991	290182	06853		9974100095	50451	36581	
9926101992	286172	06853		9974100096	B11003	36581	
9926101993	290181	06853		9974100097	50450	36581	
9926101994	290190	06853		9974100098	A11008	36581	
9926101995	290184	06853		9974100132	A11112X	36581	
9926101996	245050	06853		9974100233	50288	36581	
9926101997	290183	06853		9974100247	50332	36581	
9926102038	36012	77521		9974100272	50396	36581	
9926102039	356267	77521		9974100561	50458	36581	
9926102041	406351	77521		9974100562	50540	36581	
9926102042	491674	77521		9974100563	50459	36581	
9926102043	784917	77521		9974100564	50543	36581	
9926102044	408857	77521		9974100566	50558	36581	
9926102046	360585	77521		9974100567	30583	36581	
9926102047	493410	77521		9974100570	A11143X	36581	
9926102115	407193	77521		9974100639	50390	36581	
9926102116	360644	77521		9974100643	50585	36581	
9926102117	405952	77521		9974100646	50555	36581	
9926102250	360722	77521		9974100647	50364	36581	
9926102269	707558	77521		9974100648	50326	36581	
9926102355	114289	11331		9974100649	50553	36581	
9926102359	988882	77521		9974100651	50590	36581	
9926102360	400928	77521		9974100652	50365	36581	
9926102361	711221	77521		9974100653	50575	36581	
9974100001	50099	36581		9974100658	50590	36581	
9974100002	50098	36581		9974100662	50046	36581	
9974100003	A11041	36581		9974100663	B22594	36581	
9974100004	51010	36581		9974100664	51048	36581	
9974100007	51009	36581		9974100672	B22599	36581	
9974100008	A11001	36581		9974100673	51049	36581	
9974100009	50323	36581		9974100674	A22785	36581	
9974100010	50275	36581		9974100675	A22776	36581	
9974100015	51011	36581		9974100676	A22772	36581	
9974100016	A11007	36581		9974100677	50298	36581	
9974100017	50327	36581		9974100678	A22773	36581	
9974100018	51013	36581		9974100679	51047	36581	
9974100019	51012	36581		9974100680	A22786	36581	
9974100021	A11029	36581		9974100681	A22784	36581	
9974100022	50391	36581		9974100684	51118	36581	
9974100024	50462	36581		9974100685	51124	36581	
9974100026	A11009	36581		9974100686	51117	36581	
9974100027	50338	36581		9974100687	51116	36581	
9974100031	51004	36581		9974100689	50796	36581	

MANUFACTURER TO VENDOR CROSS REFERENCE INDEX

<u>PART NUMBER</u>	<u>VENDOR PART NUMBER</u>	<u>VENDOR CODE</u>	<u>QTY PER VEHICLE</u>	<u>PART NUMBER</u>	<u>VENDOR PART NUMBER</u>	<u>VENDOR CODE</u>	<u>QTY PER VEHICLE</u>
9974100491	F266	36581					
9974100692	50826	36581					
9974100697	C11084S	36581					
9974100698	C11084XS	36581					
9974100699	51322	36581					
9974100700	C11085	36581					
9974100701	C11086	36581					
9974100702	C11087	36581					
9974100703	50345	36581					
9974100704	B11086X	36581					
9974100705	A11124	36581					
9974100706	B11085	36581					
9974100707	C11089	36581					
9974100717	51311	36581					
9974100718	A11135X	36581					
9974100720	50546	36581					
9974100837	C11106X-13	36581					
9974100840	C11559X-13	36581					
9974101036	53364	36581					
9974101037	53365	36581					
9974101043	50521	36581					
9974101047	50963	36581					
9974101114	52555	36581					
9974101115	A11118	36581					
9974101116	52551	36581					
9974101117	52177	36581					
9974101118	52154	36581					
9974101119	54486	36581					
9974101120	52506	36581					
9974101121	52175	36581					
9974101122	52171	36581					
9974101123	52314	36581					
9974101124	51898	36581					
9974101125	52173	36581					
9974101126	51001	36581					
9974101127	54489	36581					
9974101129	52174	36581					
9974101129	52313	36581					
9974101130	52218	36581					
9974101131	52219	36581					
9974101132	52217	36581					
9974101133	52216	36581					
9974101134	B11096X-13	36581					
9974101135	52829	36581					
9974101136	50429	36581					
9974101137	51899	36581					
9974101138	50569	36581					
9974101139	54372	36581					
9974101140	54370	36581					

VENDOR CODE LISTING

D-1/(D-2 Blank)

VENDOR CODE LISTING

CODE	VENDOR NAME & ADDRESS	CODE	VENDOR NAME & ADDRESS
00163	CHILTON METAL PRODUCTS DIV. WESTERN INDUSTRIES, INC. 300 BREED STREET CHILTON, WI. 3014	07322	MINNESOTA RLUBER COMP.NYL 3630 WOODDALE AVENUE MINNEAPOLIS, MN 53416
00624	AEROQUIP CORPORATION ALRCRAFT DIV. JACKSON PLANT 300 S. EAST AVNIUE JACKSON, MI 49203	07533	BATTERSB CORPORATION NW COR YORK & WOODLAXD ROAD P. O. BOX 249 ABINGTON, P.A 19001
00779	A.MP INCORPORATED BOX 3608 HARRISBURG, PA 17105	07988	AMBAC INDUSTRIES, INC. FLUID POWER SYSTEM DIV. 511 GLENN AVENUE WHEELING, IL 6009Q
01632	RIKER MANUFACTURING, INC. 4901 STICNEY AVE. TOLEDO, OH 43612	08654	RHP BEARING, INC. 200 CLEARBROOK ROAD ELMSFORD, SY 10523
01976	AMERICAN CHALN & CABLE CO., INC. 929 CONNECTICUT AVENUE BRIDGEPORT, CT 06602	08928	ABBOTT SC.RE & MFG. CO. 6525 N. CLARK STREET CHICAGO, IL 60626
03010	TRISTATE ELECTRICAL SUPPLY CO., MNC 1741 DUAL HIGHWAY P. O. BOX 469 HAGERSTOWN, MD 21740	09094	WALDICK AEROSPACE DEVICES, INC. 2121 RT. :35 P. O. BOX 1169 WALL, NJ 07719
04609	WILLIAMS TOOL & MACHINE DIV. OF WALTER KIDDE AND CO. 1160 FAHS STREET YORK, PA 17404	09704	SEAT, INC. 350 N. DEWEY P. O. BOX 60 REEDSBURG, WI 53959
04638	CONTROLEX CORP. OF AMERICA FIELDS LANE CROTON FALLS, MY 10519	10129	REXFORD, INC. HYDRAULIC COMPONENTS DIV. 4675 CLARK ROAD P. O. BOX 11648 SARASOTA, FL 35378
04962	AIRLITE HYDRAULICS CORP. XPRESSWAY 95 INDUSTRIAL, PARK CORNWWLLS HEIGHTS, PA 19020	11331	WILLIAMS AIR CONTROLS DIV. OF WEAER COMPALNY 14100 S. W. 72ND STREET PORTLAND, OR 97223
05262	DISOGRIN INDUSTRIES MANCHESTER MUNICIPAL .AIRPORT MANCHESTER, NH 03103	11363	BEARDIGS, INC. WHITEFORD ROAD YORK, PA 17402
06853	BENDIX CORPORATION HEAVY VEHICLE SYSTEMS GROUP 901 CLEAVLAND STREET ELYRIA, OH 44035	12361	GROVE MANUFACTURING COMP.NY DIV. OF KIDDE WALT AND CO., INIC. BOX 21 SHADY GROVE, P.A 17256
07176	KARMAZIN PRODUCTS CORPORATION 3776 EVENT STREET WYANDOTTE, MI 48192	13445	COLE-HERSEE COMPANY 20 OLD COLONY AVENUE BOSTON, MA 02127

VENDOR CODE LISTING

CODE	VENDOR NAME & ADDRESS	CODE	VENDOR NAME & ADDRESS
13827	J. M. HUBER CORPORATION YALE MACHINE DEPARTMENT P. O. BOX 10717 125 W. CROSS TIMBERS HOUSTON, TX 77018	20984	ARROW SAFETY DEVICE COMPANY ROUTE 113 P. O. BOX 289 GEORGETOWN, DE 19947
13829	COMMERCIAL SHEARING, INC. 1775 LOGAN AVENUE YOUNGSTOWN, OH 44501	21335	FAFNIR BEARING COMPANY DIV. TEXTRON, LNC. 37 BOOTH STREET NEW BRITAIN, CT 06050
13929	SELECTRONS LTD. 116 EAST 16TH STREET NEW YORK, NY 10003	22075	KELSEY AXLE & BRAKE DIV. P. O. BOX 99 5800 W. DONGES BAY ROAD MEQUON, WI 53092
14242	VOSS INDUSTRIES, INC. 2168 W. 25TH STREET CLEVELAND, OH 44113	22337	FIRESTONE TIRE & RUBBER CO GOVERNMENT CONTRACTS DIV. 1200 FIRESTONE PKY. AKRON, OH 44317
14726	HOLLINGSWORTH SOLDERLESS TERMINAL COMPANY NUTT AND FRENCH CREEK ROAD PHOENIXVILLE, PA 19460	23040	FORD MOTOR COMPANY FORD PARTS & SERVICE DIV. GOVERNMENT PARTS SALES P. O. BOX 3000 29500 PLYMOUTH ROAD LIVONIA, MI 48151
16476	DATCON INSTRUMENT COMPANY 1021 COMMERCIAL AVENUE P. O. BOX 128 LANCASTER, PA 17601	24161	THE GATES RUBBER COMPANY 999 SOUTH BROADWAY DENVER, CO 80217
16764	DELCO-REMY DIV. GENERAL MOTORS CORP. 2401 COLUMBUS AVENUE ANDERSON, IN 46011	27647	WARN INDUSTRIES 13270 S. E. PHEASANT CT. MILWAUKIE, OR 97222
18242	THE BRISTOL SPRING MFG. CO. 123 WHITING-RULTENIUS STREET P. O. BOX 85 PLAINVILLE, CT 06062	27737	LINCOLN BEARING CO., LIC. 1 INA DRIVE CHERAW, SC 29520
18265	DONALDSON CO., INC. P. O. BOX 1299 MINNEAPOLIS, MN 55440	28150	METAL PRODUCTS MFG. CO. 10602 MIDWAY AVE. CERRITOS, CA 90701
19220	EBERHARD MFG. CO. 21944 DRAKE ROAD STRONGSVILLE, OH 44136	28138	HENDRICKSON MFG. CO. 3001 W. 47TH STREET LYONS, IL 60534
19239	ECHLIN MFG. CO. ECHLIN RD. & US 1 BRATFORD, CT 06405	30327	ITE IMPERIAL CORPORATION SUBSIDIARY OF GOULD, INC. VALVE & FITTING DIV. 6300 W. HOWARD STREET CHICAGO, IL 60648
20075	ELECTRIC WELDING MACHINE CO. DETROIT, MI		

VENDOR CODE LISTING

CODE	VENDOR NAME & ADDRESS	CODE	VENDOR NAME & ADDRESS
32461	LINCOLN ST. LOUIS DIV. MCNEIL CORPORATION MODULAR LUBE SALE D IV. 4010 GOODFELLOW BLVD. ST. LOUIS, MO 63120	43766	NICE BALL BLERING COMPANY' 30TH & HUNTING PARK AVENUE PHILADELPHL-, PA 19140
32828	KEENE CORP. KAYDON BFARTNG DIV. 2860 MCCRAC.C-N MUSX:GON, MI. 49443	46522	HUPP CORP. MOBLE PROCD. DIV. 1135 IVANHOE ROAD CLEAVLAND, OH 44110
33457	FLEETGUARD, NSC. 8204 ELMBROOK DRIVE SUITE 250 DALLAS, TX 75247	50153	ROYAL INDUSTRIES ANCHORLOC DIV. 2910 E. AN.A STREE. COMPTON, CA 90221
33525	KIDDE WALTER & CO., NIC. 675 MAIN STREET BELLEVILLE, NJ 07109	50620	MILLER PRODUCTS COMPALNY HIGHWAY 69 N OSCEOLA, LA 50213
34362	CIRCLE SEAL CORPORATION 1111 N. BROOKHUST STREET P. O. BOX 3666 ANAHEM, CA 92803	30996	UNITED HYDRAULICS CORP. HIGHWAY 3E P. O. BOX 88 WAVERLY, LA 50677
36479	LIPE-ROLLWAY CORPORATION 806 EMERSON AVENUE P. O. BOX 1397 SYRACUSE, SY 13201	51205	DANA CORP. 4500 DORR STREET P. O. BOX 1000 TOLEDO, OH 43601
36540	LISLE CORPORATION 805 MAIN STREET CLARINDA, LIA 51632	51731	AUTO METER PRODUCTS 22 S. STATE STREET ELGIN, IL 60120
36581	GEARMATIC CO. LTD. DIV. OF PACCAR OF CANADA LTD. 7400 132ND STREET N SURREY B. C. CANADA V3T 4X	52304	EATON CORPORATION TRUCK COMPONENTS 26101 NORTHWESTERN HWY. SOUTHFIELD, MI 48076
36618	GEERAL ELECTRIC COMPANY BALTIMORE OPERATIONS 2525 INSULATOR DRIVE BALTIMORE, MD 21230	52729	UNITED EQPT. ACCESSORIES, INC. HIGHWAY 3E WAVERLY, LA 50677
41625	MORSE CONTROLS DIV. OF ICOM NTSR.NATIONAL INC. 21 CLINTON STREET HUDSON, OH 44236	53203	KRU-BUR INC. 900 PINGREE ROAD ALGONQULIN, IL 60102
43334	NEW DEPARTURE HYATT BLERING DIV. GENERAL MOTORS CORP. 2509 HAYES AVENUE SANDUSKY, OH 44870	53790	STAUFF CORPORATICN 41 NEWMAN STREET HACKNSACK, NJ 07601
		54220	GLG SYSTEMS, INC. 11152 CONDOR AVENUE FOUNTAIN VALLEY, CA 92708

VENDOR CODE LISTING			
CODE	VENDOR NAME & ADDRESS	CODE	VENDOR NAME & ADDRESS
56878	STANDARD PRESSED STEEL COMPANY BENSON EAST JENKINTOWN, PA 19046	70903	BELDEN CORPORATION 2000 S. RATAVIA AVLNUL GENEVA, IL 60134
57733	STEWART-WALNER CORPORATION 1826 DIVERSEY PARKWAY CHICAGO, IL 60614	71044	BOSTROM DIV. OF UOP LNC. 113 W. OREGON STREET MILWAUKEE, WI 53204
59730	THOMAS & BETTS COMPANY 36 BUTTLER STREET ELIIZABETH, NJ 07207	71400	BUSSMANN MFG. DIV. MCGRAW-EDISON COMP.ANY 502 FARTE CITY PTA7 EART CITY, MO 63045
60038	TIMIEN COMPANY 1835 DUEBER AVE. SW CANTON, OH 44706	71741	CHICAGO MA 1ACIUkxING COMPA.NY 1855 S. 54TH AVENUE CHICAGO, IL 60650
60380	THE TORRINGTON COMPANY SUBSIDIARY OF INGERSOLL-RAND CORP. 59 FIELD TORRINGTON, CT 06790	71744	CHICAGO MINL'UREI/DRAKE 4433 RAVENSWOOD AVENUE CHICAGO, IL 60640
61038	SPERRY VICKERS TULSA 7217 E. PINE STREET P. O. BOX C ADMIRAL STA. TULSA, OK 74115	71749	THE CROMWELL P.APE COMPANY 222 N. MICHIGAN AVENUE CHICAGO, IL 60601
61349	AMETEK/U.S. GAUGE 909 CLYXER AVENUE SELLERSVILLE, PA 18960	72582	DETROIT DIESEL ALLISON DIV. OF GENERAL MOTORS CORP. 13400 W. OUTER DRIVE DETROIT, MI 48228
63477	WAGNER ELECTRIC CORPORATION WAGNER DIV. 6400 PLYMOUTH- AVENUE ST. LOUIS, MO 63133	72653	GE ELECTRONICS COMPANY A DIV. OF HYDROMETALS, INC. 400 S. WYMAN STREET ROCXFORD, IL 61101
66295	WITTER MFG. A MICRO DOT COMPANY 1421 BARNSDALE ROAD LA GRANGE PARK, IL 60525	72741	DORMAN PRODUCTS COMPANY 10000 ALLIANCE ROAD CINCINNATI, OH 45242
70412	THE ANDERSON COMPANY 1075 GRANT STRVFT GARY, IN 46440	72807	ANCHOR COUPLING INC. 50 BELLVUE ROAD P. O. BOX 928 NEWARK, DE 19711
70485	ATIALNTIC INDIA IUBBER WORK 571 W. POLK S\$Tfr7T CHICAGO, IL 60607	72902	GREENE TWEE & CO., INC. 320 ELM AVENUE NORTH WALES, PA 19454
70847	BAND-IT COMPANY 4757 DAHLIA STPFVT DENVER, CO 80216	73331	GUIDE LAMP DIV. OF GENERAL MOTORS CORP. 2915 PENDELTON AVENUE ANDERSON, IN 46011

VENDOR CODE LISTING

CODE	VENDOR NAME & ADDRESS	CODE	VENDOR NAME & ADDRESS
			P. O. BOX 5177 BOSTON, MA 02122
73808	GNFRAT, TIRE & RUBBER COMPANY ONE GENERAL STREET AKRON, OH 44329		
		77521	RE-ORD, ITC. HYDRAULIC COMPONENTS D IV. 2200 NORTHWESTERN AVENUE RACINE, WI 53404
73842	GOODYEAR TIRE & RUBBER COMPANY 1144 E. M.ARK'7T AKRON, OH 44316		
		77640	TRW INC. ROSS GEAR DIVISION 800 HEATH STREET LAFAYETTE, LA 70702
73972	GUNITE DIVISION 302 PEOPLES AVENUE ROCKFORD, IL 61101		
		78500	ROCKWELL INTERNATIONAL 2135 WEST MAPLE ROAD TROY, MI 48064
74687	HUNTINGTON RUBBER CORPORATION P. O. BOX. 570 PORTLAND, OR 97207		
		79136	VALDES KOHINOOR, INC. 47-16 AUSTEL PLACE LONG ISLAND CITY, NY 11101
75174	JOHNSON BRONZE 500 S. MILL STREET NEW CASTLE, PA 16103		
		79146	VELVAC LNC. 2900 SOUTH 160TH STREET NEW BERLIN, WI 53151
75175	K-D LAMP COMPANY! 1910 ELM STREET CINCINNATI, OH 45210		
		79470	WEATHERHEAD COMPANY 300 E. 131ST STREET CLEVELAND, OH 44108
75272	KICKHAM- HMF. CO. 1964 WISCONSIN AVENUE P. O. BOX 104 GRAFTON, WI 53024		
		80201	CHICAGO RAWHIDE MFG. CO. 900 N. STATE STREET ELGIN, IL 60120
75535	THE CROSBY GROUP DIV. OF AMERICAN HOIST & DERRICK CO		
	2511 TAYLOR STREET P. O. BOX 570 FT. WAYNE, IN 46804	80406	BETHLEHEM STEEL CORPORATION 701 E. 3RD STREET- BETHLEHEM., PA 18016
76005	LORD KINEMATICS, LORD CORP. 1635 W. 12TH STREET P. O. BOX 8069 ERIE, PA 16512		
		80813	DIMCO-GRAY COMPANY 8200 S. SUBURBAN ROAD CENTERVILLE, OH 45459
76599	MURRAY CORPORATION SCHILLING CIRCLE GREATER BALTIMORE INDUSTRIAL PARK		
	COCKEYSVILLE, MD 21030	81168	HERCULES PRODUCTS DIV. RICHARDSON CORP. 11061 WALDEN ROAD ALDEN, NY 14004
77146	PEABODY COAL CO. 301 N. MEMORIAL DRIVE ST. LOUIS, MO 63102		
		81493	PHOENIX PRODUCTS CO., INC. 4715 NORTH 27TH STREET MILWAUKEE, WI 53209
77326	JOSEPH POLLAK CORPORATION 195 FREEPORT ST.		
		81834	GROTE MFG. CO. STAR ROUTE #17 P. O. BOX 766 MADISON, IN 47250

VENDOR CODE LISTING

CODE VENDOR NAME & ADDRESS

CODE VENDOR S&E & ADDRESS

82084 GEIER & BLUIM INC.
593 RIVER STREET
TROY, NY 12180

82666 STOCIHAM VALVE AND FITTING, INC.
4000 N. 10TH AVENUE
BIRMTNGHAM, AL 35202

83259 PARKER SEAL COMPANY
DIV. OF PARKER-RANNILFI CORP.
10567 JEFFERSON BLVD.
CULVER CITY, CA 90231

84830 LEE SPRING COMPANY
30 MAIN STREET
BROOKLYN, NY 11201

87373 PARER HATNIFIN CORP.
HOSE AND COUPLING DIV.
30240 LAKFAND BLVD.
WICKIFFE, OH 44092

88220 GOULD INC.
10 GOULD CENTEB
ROLLING MEADOWS, IL 60008

90005 FACET ENTERPRISES, INC.
FILTER PRODUCTS DIV.
434 W. 12 MILE ROAD
P. O. BOX 135
MADISON HEIGHTS, HI 48071

90526 CLIPPARD INSTRUMENT LAB, INC.
7390 COLERAIN ROAD
CINCINNATI, OO 45239

90763 THE A UNITED CARR CO.
CARR DIV. OF TRW INC.
10544 LUNT AVENUE
ROSEMONT, IL 60018

92830 ASSOCIATED SPRING CORPORATION
BARNES GROUP, INC.
18 MAIN STREET
BRISTOL, CT 06010

92857 GENERAL RADIATOR, INC.
CHROMALLOY AMERICAN CORP.
P. O. BOX 948
MT. VERNON, IL 62864

92865 MINNESOTA AUTOMOTIVE
1911 LEE BLVD.
NORTH MANKOTO, MN 56001

92867 ORSCHELN BRAKE LEVER MFG. CO.
1177 N. MORLEY STREET
MOBERLY, MO 65270

92878 HUNTER MFG. CO.
30525 AURORA ROAD
CLEVELAND, OH 44139

93259 SEE 83259

93393 FEDERAL STAMPINGS
2000 WEST 94TH STREET
MNNEAPOLIS, MU 5543]

93736 VICKTOR SPECIALTIES, DNC.
775 MAIN STREET
NEW ROCHELLE, NY 10805

94222 SOUTHCO, INC.
LESTER, PA 19113

94431 DANA CORP.
GARRISON HYDRAULICS PLANT
2321 S. PULLMAN AVENUE
P. O. BOX 15407
SANTA ANA, CA 92705

96105 FUNK MFG. CO.
DIV. OF GARDNER-DENVER CO.
INDUSTRIES PARK
1211 W. 12TH STREET
COFFEYVILLE, KS 67337

96151 EATON CORP. FLUID POWER DIV.
CHAR-LYNN PLANT
15151 HIG'WAY 5
EDEN PRAIRIE, MN 55343

96906 MILITARY STANDARDS
PROLGATED BY MILZTARY
DEPARTMENTS UNDER AUTHORITY
OF DEFENSE STANDARDIZATION
MANUAL 4120 3H

97576 LENZ FLUID POWER ACCESSORIES
3301 KLEPINGER ROAD
P. O. BOX 1044
DAYTON, OH 45401

By Order of the Secretary of the Army:

Official:

JOHN A. WICKHAM, JR.
General United States Army
Chief of Staff

ROBERT M. JOYCE
Major General, United States Army
The Adjutant General

Distribution:

To be distributed in accordance with DA Form 12-25B Organizational Maintenance Requirements for Cranes, Truck Mounted.

*U.S. GOVERNMENT PRINTING OFFICE: 1984-754-017/7062

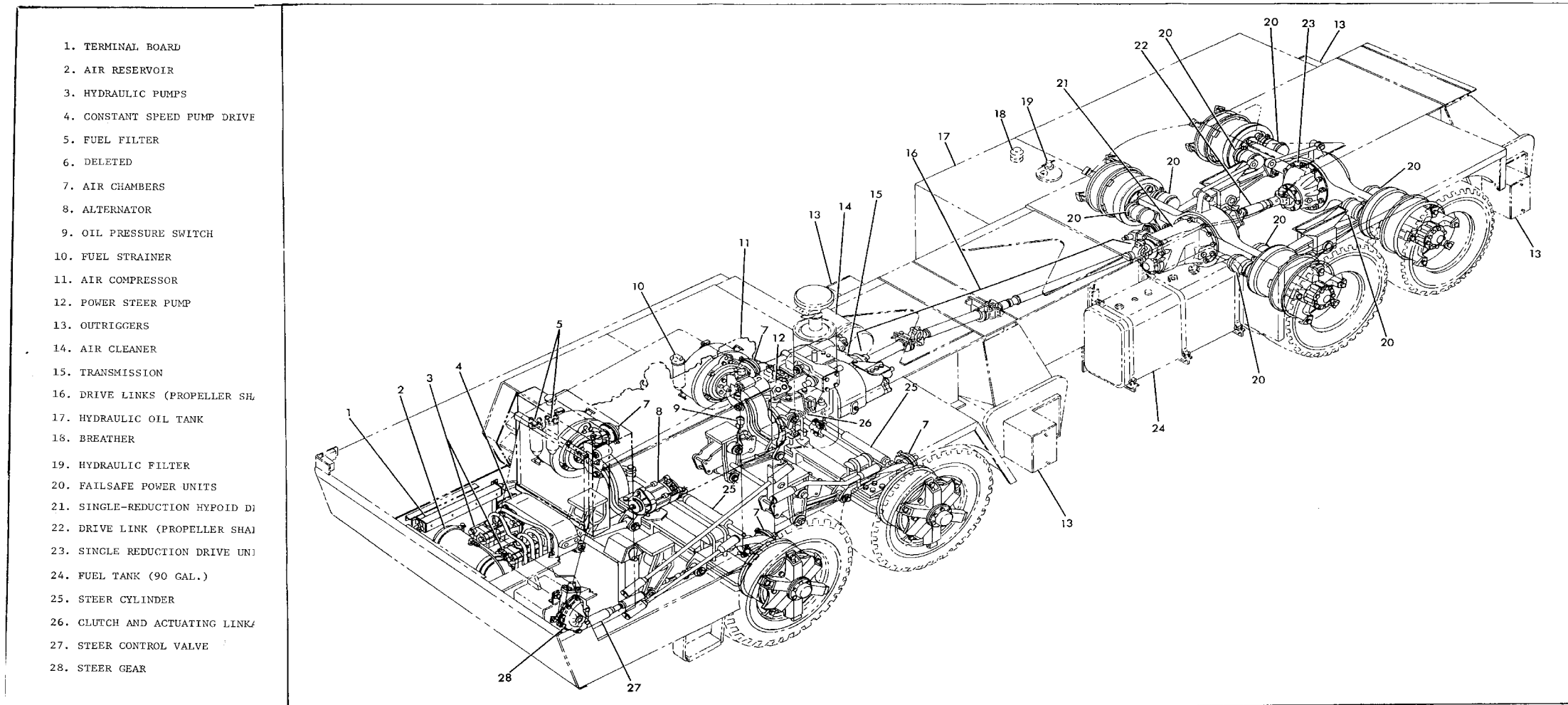
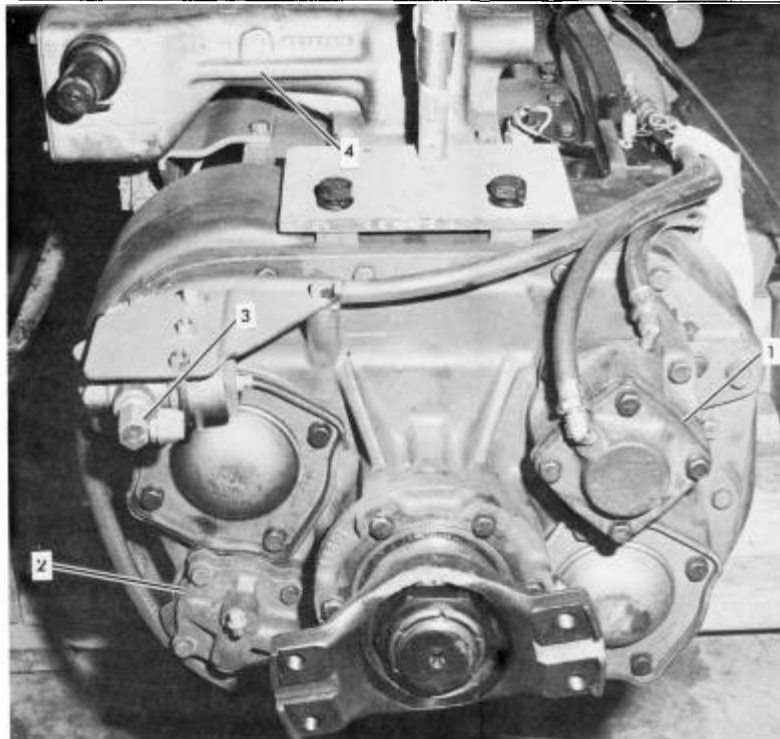

Illustration 4-1. Carrier Component Location.

4-3/(4-4 blank)



1. AUXILIARY SHIFT CYLINDER
2. INTERMEDIATE SHIFT CYLINDER
3. AIR REGULATOR AND FILTER ASSEMBLY
4. SLAVE UNIT
5. POWER TAKE-OFF
6. SLAVE AIR VALVE
7. BACK-UP LAMP SWITCH
8. SAFETY NEUTRAL SWITCH
9. MASTER CONTROL UNIT
10. COUNTERSHAFT BRAKE CONTROL
11. COUNTERSHAFT GEAR
12. MAINSHAFT GEAR
13. COUNTERSHAFT GEAR
14. RANGE CONTROL VALVE

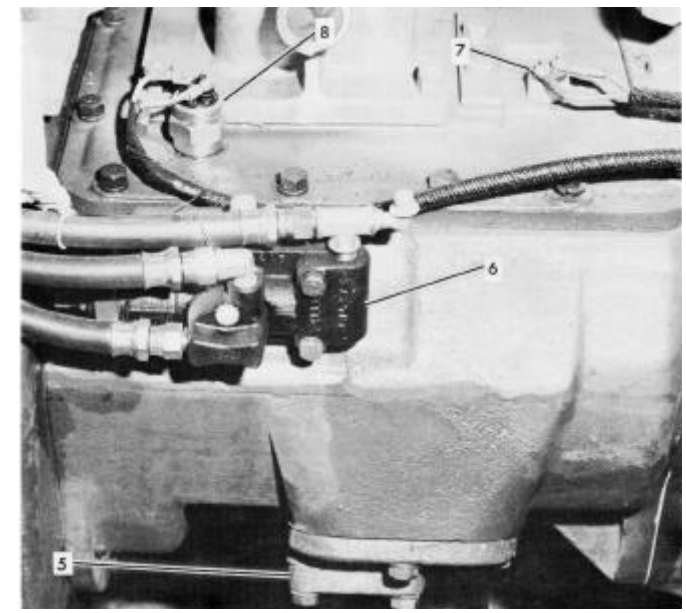
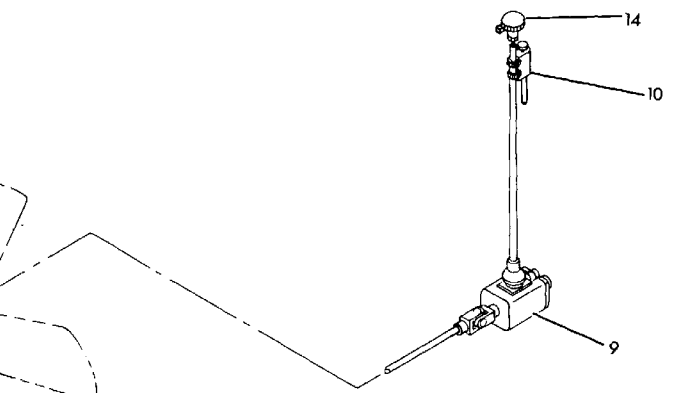
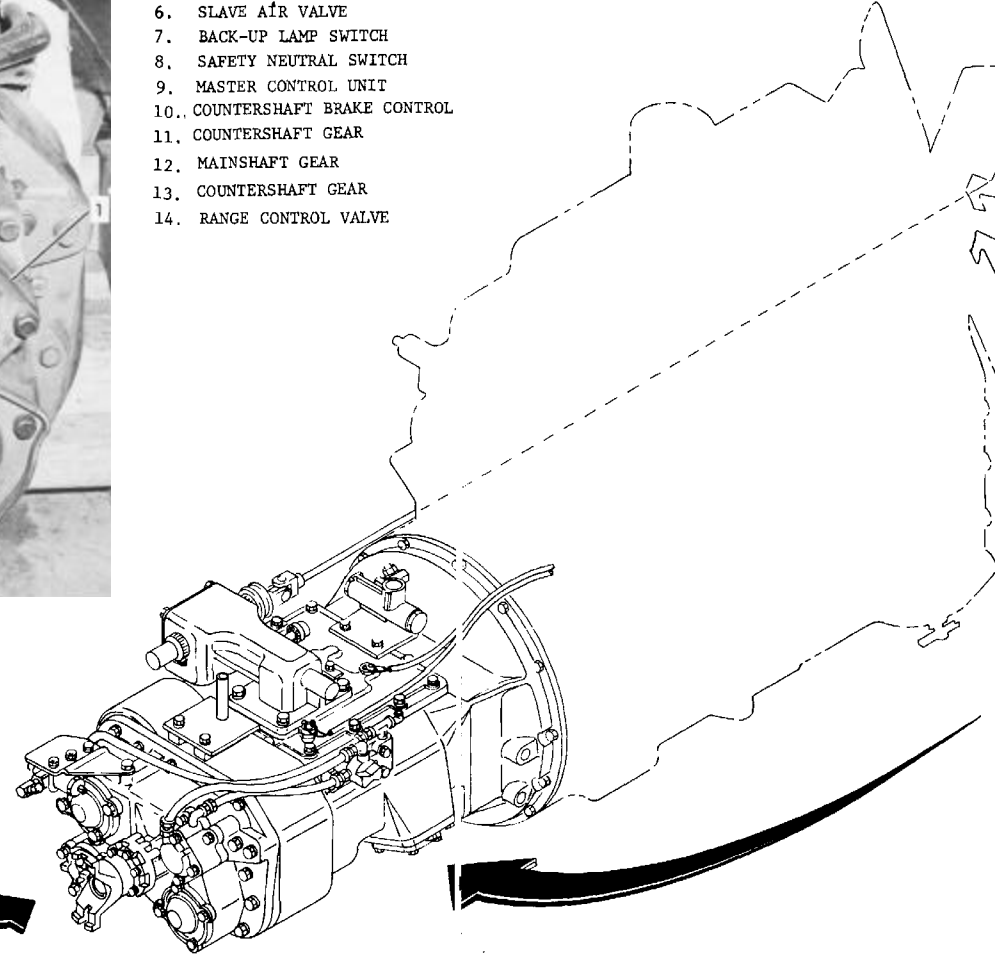
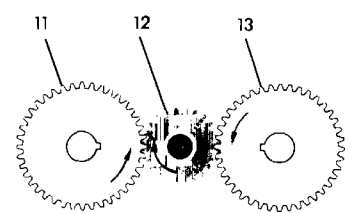

Illustration 4-8. Transmission Components.

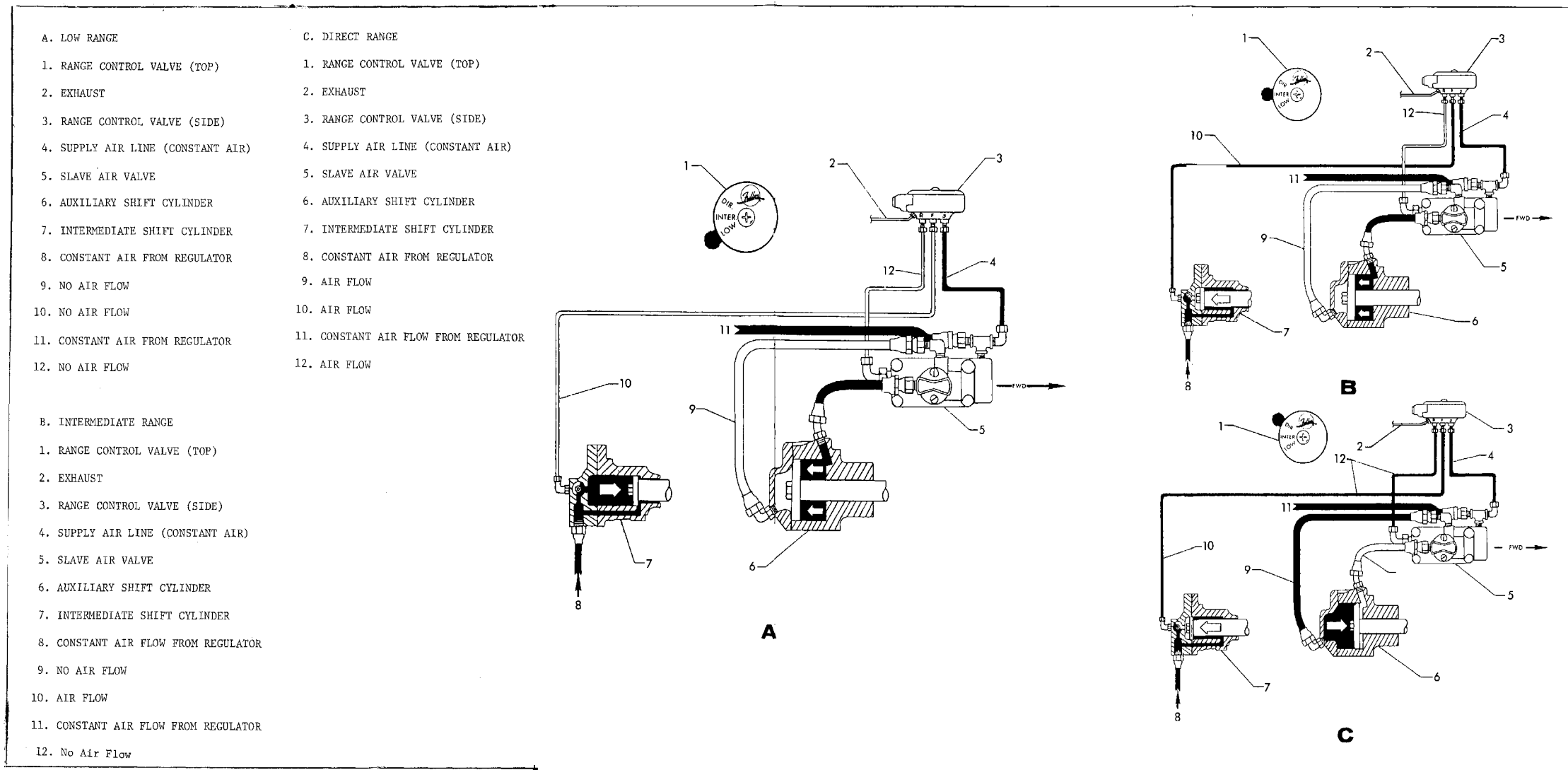
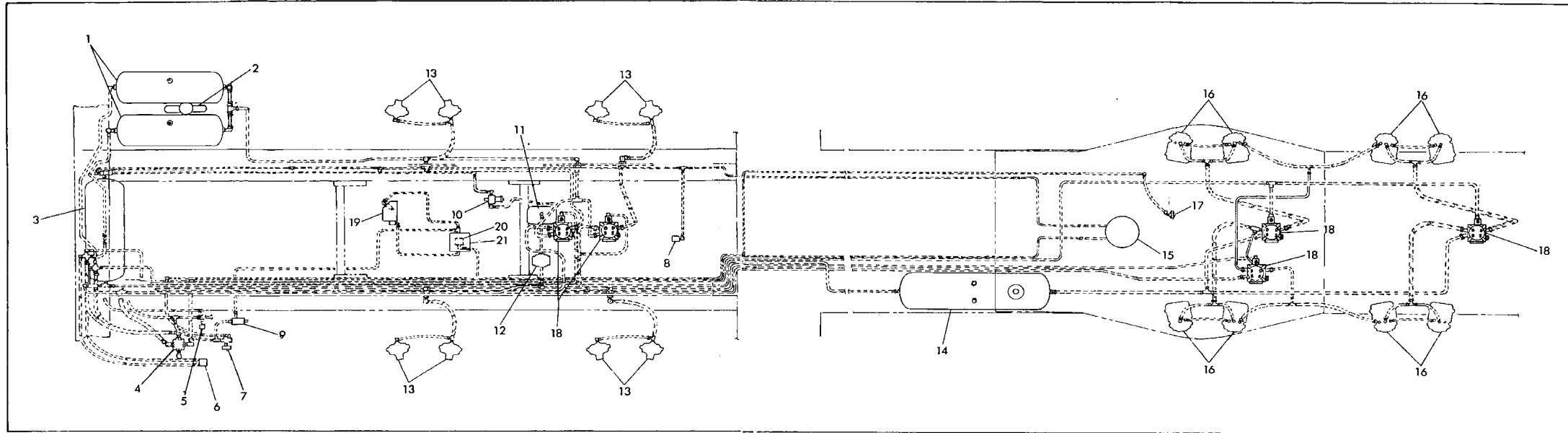

ILLUSTRATION 4-9. TRANSMISSION AIR SCHEMATIC.



- | | | | | | | |
|----------------------------|---------------------------|-----------------------------------|-------------------------|--------------------------------|------------------------|-----------------|
| 1. FRONT SERVICE RESERVOIR | 4. E-6 DUAL BRAKE VALVE | 7. AXLE LOCK VALVE | 10. COMPRESSOR GOVERNOR | 13. BRAKE AIR CHAMER ASSEMBLY | 16. SPRING BRAKE | 19. GOVERNOR |
| 2. ACCESSORY RESERVOIR | 5. PARKING BRAKE VALVE | 8. SLAVE AIR VALVE (TRANSMISSION) | 11. COMPRESSOR | 14. REAR SERVICE RESERVOIR | 17. AXLE LOCKOUT VALVE | 20. CONTROL |
| 3. SUPPLY RESERVOIR | 6. DUAL AIR PRESSURE GAGE | 9. REMOTE THROTTLE CONTROL | 12. ALCOHOL INJECTOR | 15. PNEUMATIC/HYDRAULIC SWIVEL | 18. RELAY VALVE | 21. RELAY VALVE |

Illustration 4-17. Air System (Sheet 1 of 3).

4-51/(4-52 blank)

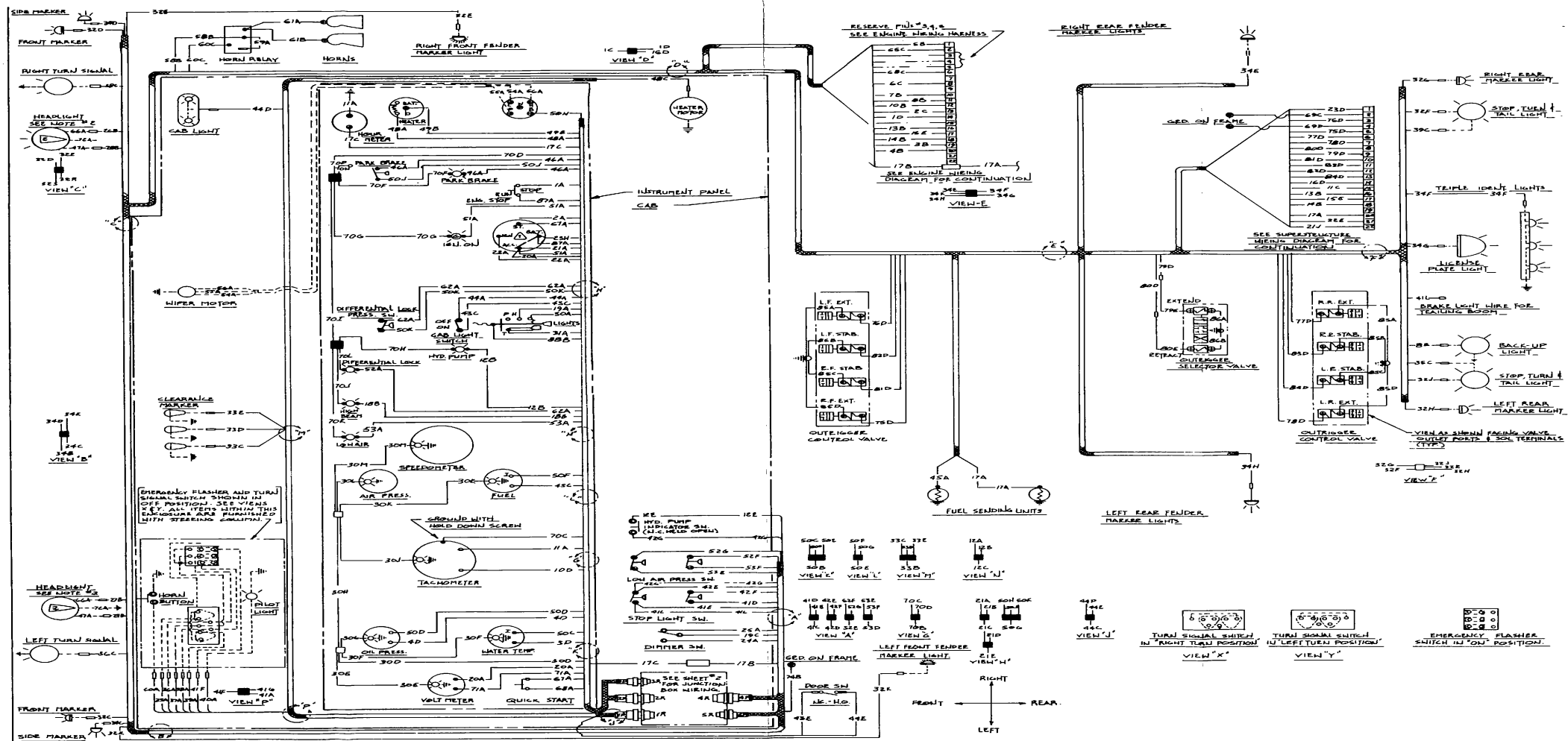
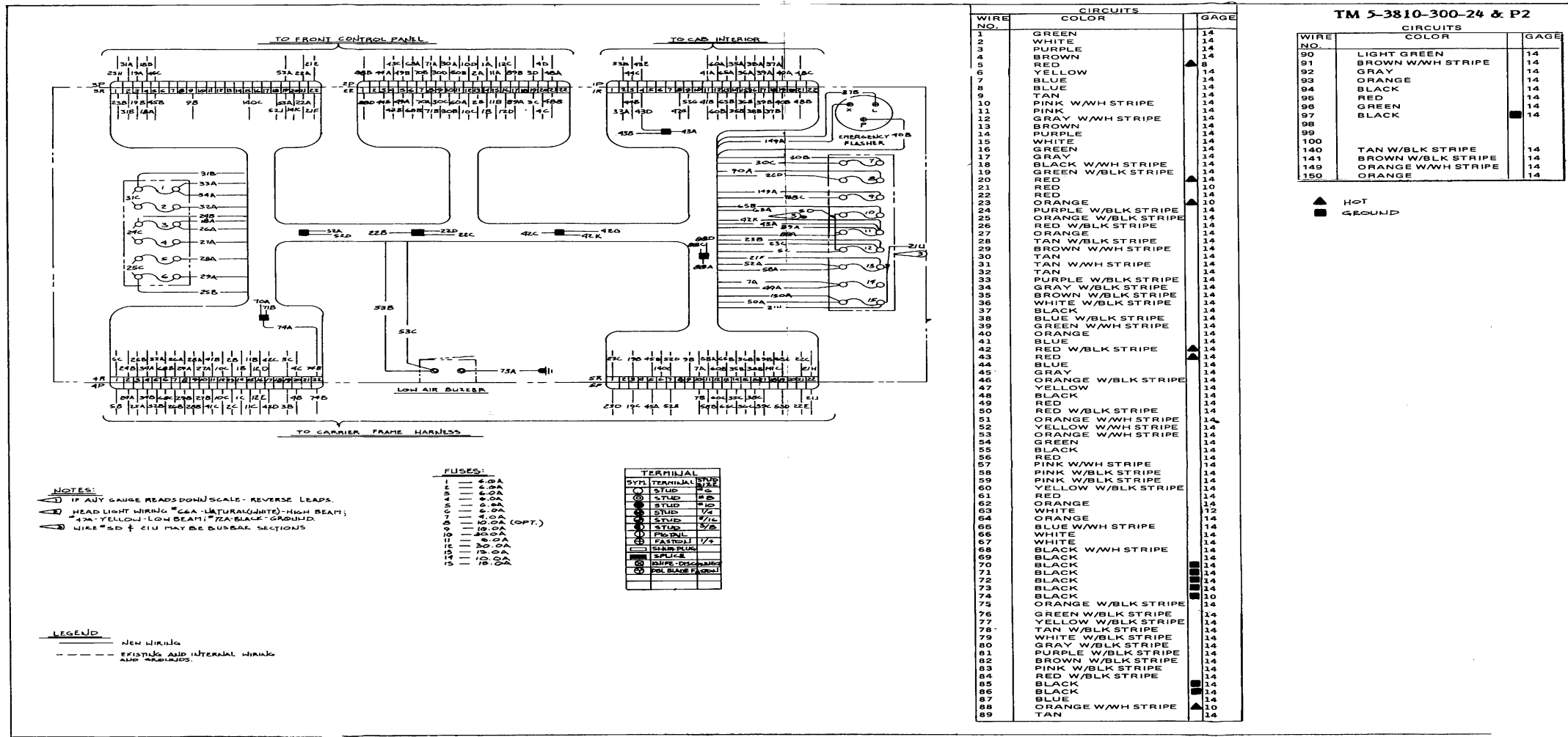

Illustration 4-20. Carrier Electrical Schematic.
(Sheet 2 of 3)

4-65/(4-66 blank)



WIRE NO.	CIRCUITS COLOR	GAGE
1	GREEN	14
2	WHITE	14
3	PURPLE	14
4	BROWN	14
5	RED	14
6	YELLOW	14
7	BLUE	14
8	BLUE	14
9	TAN	14
10	PINK W/WH STRIPE	14
11	PINK	14
12	GRAY W/WH STRIPE	14
13	BROWN	14
14	PURPLE	14
15	WHITE	14
16	GREEN	14
17	GRAY	14
18	BLACK W/WH STRIPE	14
19	GREEN W/BLK STRIPE	14
20	RED	14
21	RED	14
22	RED	14
23	ORANGE	14
24	PURPLE W/BLK STRIPE	14
25	ORANGE W/BLK STRIPE	14
26	RED W/BLK STRIPE	14
27	ORANGE	14
28	TAN W/BLK STRIPE	14
29	BROWN W/WH STRIPE	14
30	TAN W/BLK STRIPE	14
31	TAN W/WH STRIPE	14
32	TAN	14
33	PURPLE W/BLK STRIPE	14
34	GRAY W/BLK STRIPE	14
35	BROWN W/BLK STRIPE	14
36	WHITE W/BLK STRIPE	14
37	BLACK	14
38	BLUE W/BLK STRIPE	14
39	GREEN W/WH STRIPE	14
40	ORANGE	14
41	BLUE	14
42	RED W/BLK STRIPE	14
43	RED	14
44	BLUE	14
45	GRAY	14
46	ORANGE W/BLK STRIPE	14
47	YELLOW	14
48	BLACK	14
49	RED	14
50	RED W/BLK STRIPE	14
51	ORANGE W/WH STRIPE	14
52	YELLOW W/WH STRIPE	14
53	ORANGE W/WH STRIPE	14
54	GREEN	14
55	BLACK	14
56	RED	14
57	PINK W/WH STRIPE	14
58	PINK W/BLK STRIPE	14
59	PINK W/BLK STRIPE	14
60	YELLOW W/BLK STRIPE	14
61	RED	14
62	ORANGE	14
63	WHITE	12
64	ORANGE	14
65	BLUE W/WH STRIPE	14
66	WHITE	14
67	WHITE	14
68	BLACK W/WH STRIPE	14
69	BLACK	14
70	BLACK	14
71	BLACK	14
72	BLACK	14
73	BLACK	14
74	BLACK	14
75	ORANGE W/BLK STRIPE	14
76	GREEN W/BLK STRIPE	14
77	YELLOW W/BLK STRIPE	14
78	TAN W/BLK STRIPE	14
79	WHITE W/BLK STRIPE	14
80	GRAY W/BLK STRIPE	14
81	PURPLE W/BLK STRIPE	14
82	BROWN W/BLK STRIPE	14
83	PINK W/BLK STRIPE	14
84	RED W/BLK STRIPE	14
85	BLACK	14
86	BLACK	14
87	BLUE	14
88	ORANGE W/WH STRIPE	10
89	TAN	14

TM 5-3810-300-24 & P2

WIRE NO.	CIRCUITS COLOR	GAGE
14		
90	LIGHT GREEN	14
91	BROWN W/WH STRIPE	14
92	GRAY	14
93	ORANGE	14
94	BLACK	14
95	RED	14
96	GREEN	14
97	BLACK	14
98	BLACK	14
99		
100		
140	TAN W/BLK STRIPE	14
141	BROWN W/BLK STRIPE	14
149	ORANGE W/WH STRIPE	14
150	ORANGE	14

▲ HOT
 ■ GROUND

Illustration 4-20. Carrier Electrical Schematic (Sheet 3 of 3).

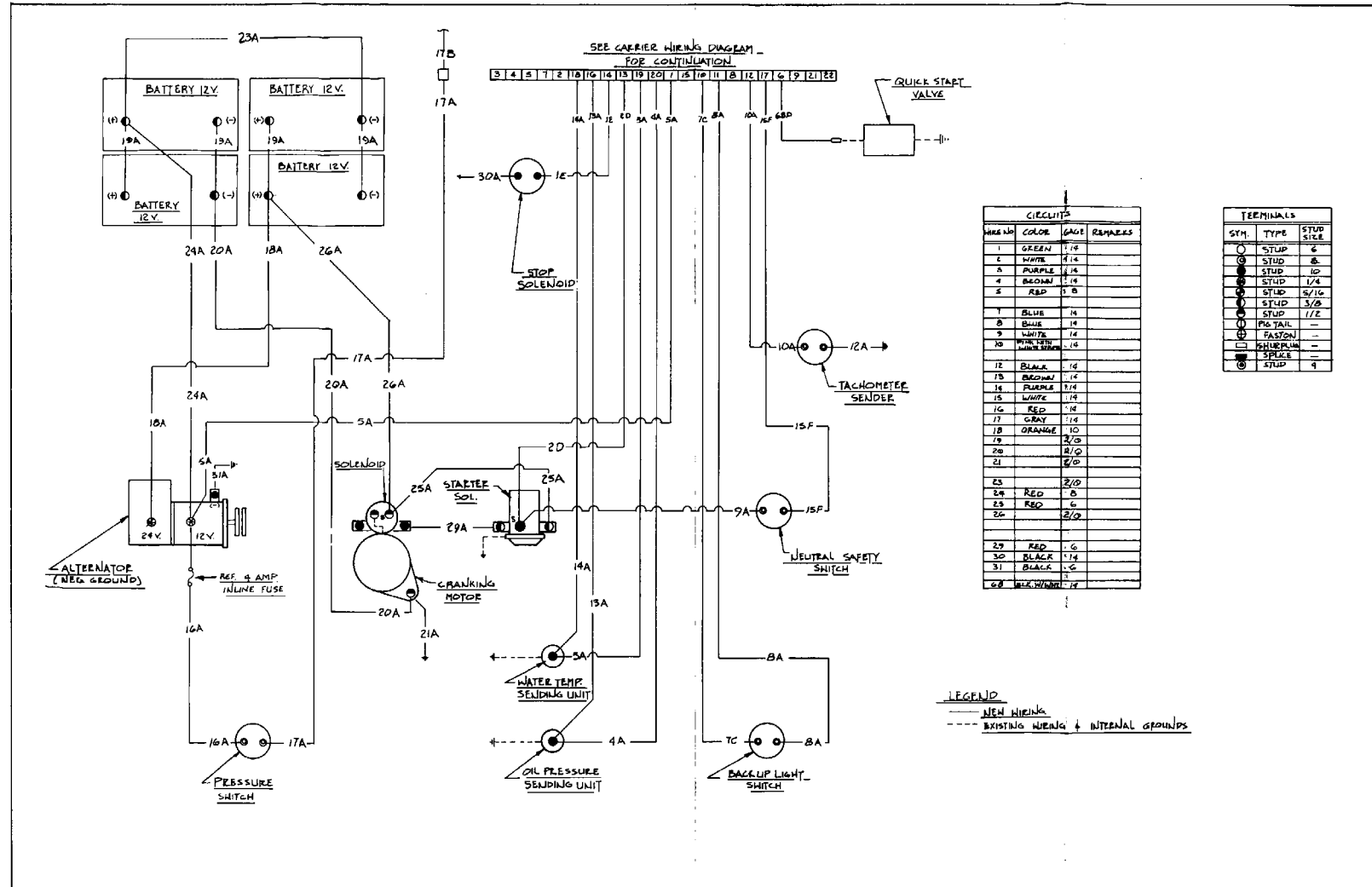
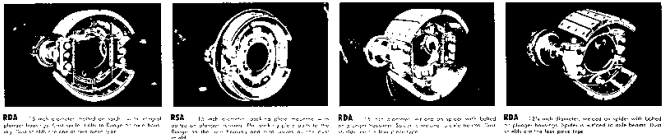

Illustration 4-21. Carrier Engine Electrical Schematic

4-69/(4-70 blank)

DESCRIPTION — The wheel has a built-in feature for lubrication adjustment, some alignment and parts replacement for the 4 basic air line types: 3/8" diameter "F" Wedge Brake, most of the information on this chart is common to a 1" diameter model.

Shown in the right are the four basic types of Brakebrake. If wedge brakes used are either front, rear or trailer axle, the "F" also may be called a "splitter brake". It was commonly employed on heavy trucks in ratings of 16,000 lbs. or more. It is a heavy-duty brake with a maximum rating of 16,000 lbs. on most "split" brake with ratings from 12,000 to 16,000 lbs. on heavy-duty split-brake of the type shown. The two standard air line sizes used brakes: 1 1/2" diameter and 1 1/4" diameter are employed on 1 1/2" air lines.



WARNING — With all outside work the power spring must be compressed before any disassembly or repair is attempted. Compress the power spring manually, or by air or hydraulic pressure depending on the type of system employed.

With an operational Super "B" Fail-Safe, the power spring is manually reeled (or compressed) by turning the caping ball clockwise approximately 75 full turns. With hydraulically operated units from the caping ball clockwise approximately 74 full turns. Uncoiling (releasing) the spring is accomplished by reversing the procedure.

Recommended Lubricant:

A high temperature water-resistant grease in a No. 1 MGLI grade is recommended for normal parking and storage temperatures. If this type of lubricant is not available a suitable grease can be obtained from Rockwell-Standard.

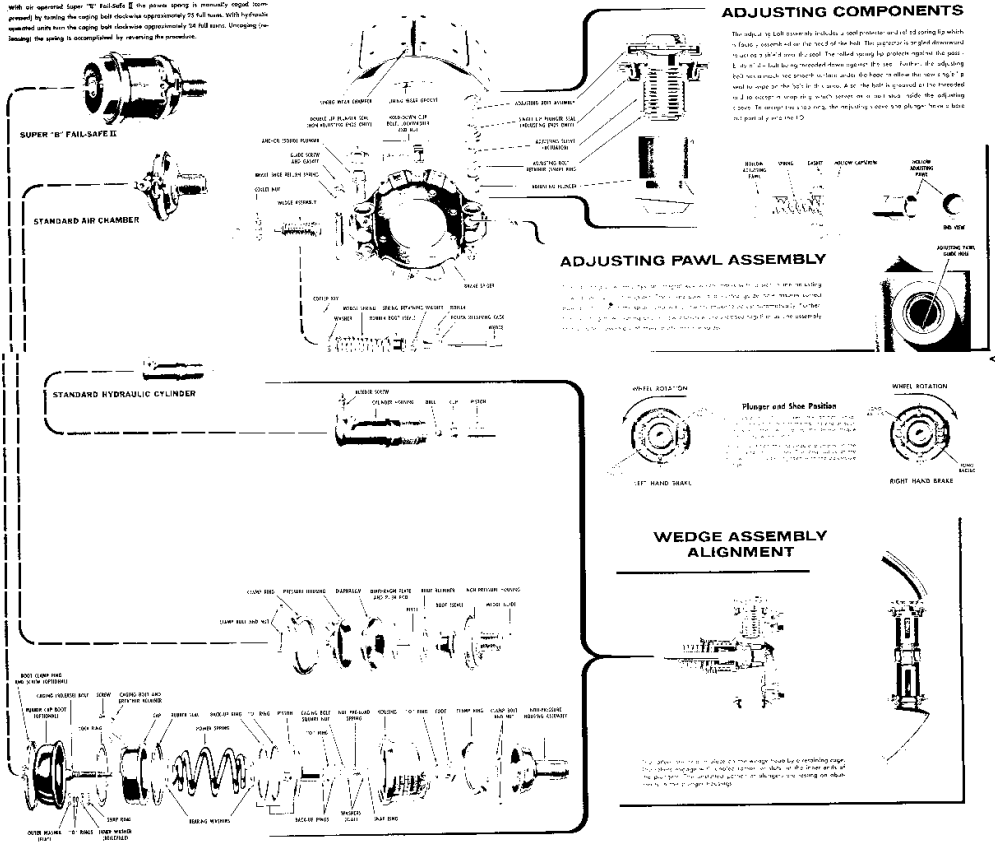

Illustration 4-54. Brake Maintenance Chart

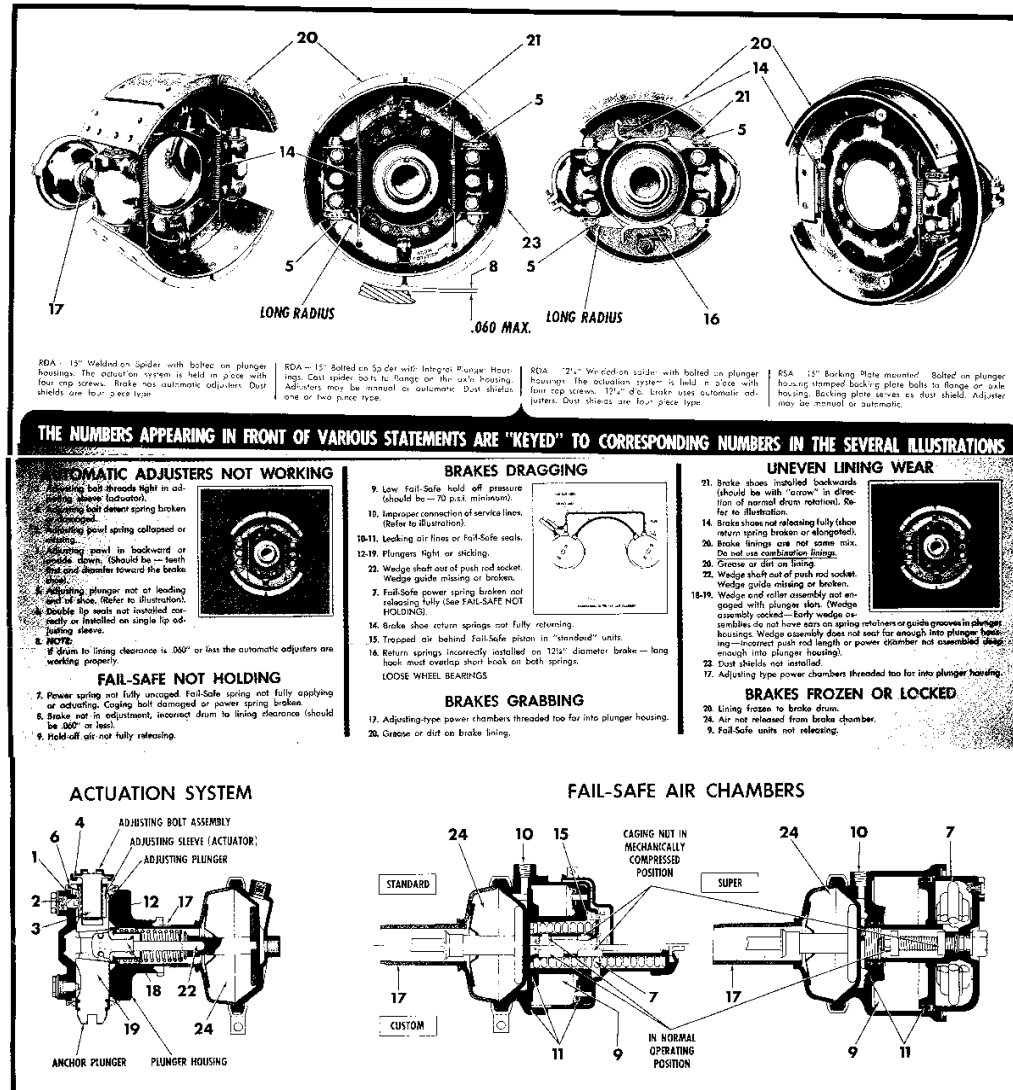

Illustration 4-55. Brake Trouble Chart

4-343/(4-344 Blank)

RECOMMENDED CHANGES TO EQUIPMENT TECHNICAL PUBLICATIONS



THEN... JOT DOWN THE DOPE ABOUT IT ON THIS FORM, CAREFULLY TEAR IT OUT, FOLD IT AND DROP IT IN THE MAIL!

SOMETHING WRONG WITH THIS PUBLICATION?

FROM: (PRINT YOUR UNIT'S COMPLETE ADDRESS)

DATE SENT

PUBLICATION NUMBER

PUBLICATION DATE

PUBLICATION TITLE

BE EXACT... PIN-POINT WHERE IT IS

IN THIS SPACE TELL WHAT IS WRONG AND WHAT SHOULD BE DONE ABOUT IT:

PAGE NO.	PARA-GRAPH	FIGURE NO.	TABLE NO.
----------	------------	------------	-----------

TEAR ALONG PERFORATED LINE

PRINTED NAME, GRADE OR TITLE, AND TELEPHONE NUMBER

SIGN HERE:

DA FORM 2028-2 JUL 79

PREVIOUS EDITIONS ARE OBSOLETE.

P.S.—IF YOUR OUTFIT WANTS TO KNOW ABOUT YOUR RECOMMENDATION MAKE A CARBON COPY OF THIS AND GIVE IT TO YOUR HEADQUARTERS.

THE METRIC SYSTEM AND EQUIVALENTS

LINEAR MEASURE

- 1 Centimeter = 10 Millimeters = 0.01 Meters = 0.3937 Inches
- 1 Meter = 100 Centimeters = 1,000 Millimeters = 39.37 Inches
- 1 Kilometer = 1,000 Meters = 0.621 Miles

SQUARE MEASURE

- 1 Sq Centimeter = 100 Sq Millimeters = 0.155 Sq Inches
- 1 Sq Meter = 10,000 Sq Centimeters = 10.76 Sq Feet
- 1 Sq Kilometer = 1,000,000 Sq Meters = 0.386 Sq Miles

CUBIC MEASURE

- 1 Cu Centimeter = 1,000 Cu Millimeters = 0.06 Cu Inches
- 1 Cu Meter = 1,000,000 Cu Centimeters = 35.31 Cu Feet

LIQUID MEASURE

- 1 Milliliter = 0.001 Liters = 0.0338 Fluid Ounces
- 1 Liter = 1,000 Milliliters = 33.82 Fluid Ounces

TEMPERATURE

- $5/9 (^{\circ}\text{F} - 32) = ^{\circ}\text{C}$
- 212° Fahrenheit is equivalent to 100° Celsius
- 90° Fahrenheit is equivalent to 32.2° Celsius
- 32° Fahrenheit is equivalent to 0° Celsius
- $9/5 \text{ } ^{\circ}\text{C} + 32 = \text{ } ^{\circ}\text{F}$

WEIGHTS

- 1 Gram = 0.001 Kilograms = 1,000 Milligrams = 0.035 Ounces
- 1 Kilogram = 1,000 Grams = 2.2 lb.
- 1 Metric Ton = 1,000 Kilograms = 1 Megagram = 1.1 Short Tons

APPROXIMATE CONVERSION FACTORS

TO CHANGE	TO	MULTIPLY BY
Inches	Centimeters	2.540
Feet	Meters	0.305
Yards	Meters	0.914
Miles	Kilometers	1.609
Square Inches	Square Centimeters	6.451
Square Feet	Square Meters	0.093
Square Yards	Square Meters	0.836
Square Miles	Square Kilometers	2.590
Acres	Square Hectometers	0.405
Cubic Feet	Cubic Meters	0.028
Cubic Yards	Cubic Meters	0.765
Fluid Ounces	Milliliters	29.573
Pints	Liters	0.473
Quarts	Liters	0.946
Gallons	Liters	3.785
Ounces	Grams	28.349
Pounds	Kilograms	0.454
Short Tons	Metric Tons	0.907
Pound-Feet	Newton-Meters	1.356
Pounds Per Square Inch	Kilopascals	6.895
Miles Per Gallon	Kilometers Per Liter	0.425
Miles Per Hour	Kilometers Per Hour	1.609
TO CHANGE	TO	MULTIPLY BY
Centimeters	Inches	0.394
Meters	Feet	3.280
Meters	Yards	1.094
Kilometers	Miles	0.621
Square Centimeters	Square Inches	0.155
Square Meters	Square Feet	10.764
Square Meters	Square Yards	1.196
Square Kilometers	Square Miles	0.386
Square Hectometers	Acres	2.471
Cubic Meters	Cubic Feet	35.315
Cubic Meters	Cubic Yards	1.308
Milliliters	Fluid Ounces	0.034
Liters	Pints	2.113
Liters	Quarts	1.057
Liters	Gallons	0.264
Grams	Ounces	0.035
Kilograms	Pounds	2.205
Metric Tons	Short Tons	1.102
Newton-Meters	Pound-Feet	0.738
Kilopascals	Pounds Per Square Inch	0.145
Kilometers Per Liter	Miles Per Gallon	2.354
Kilometers Per Hour	Miles Per Hour	0.621

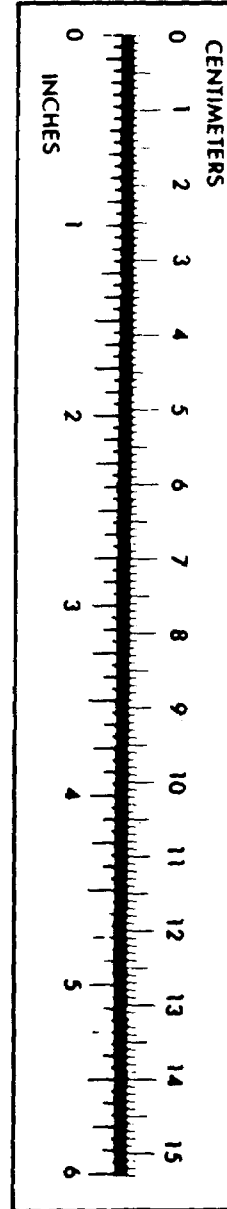

PIN: 055592-000